

$\Sigma$ -7-Series AC Servo Drive

# $\Sigma$ -7W SERVOPACK with 400V-Input Power and EtherCAT (CoE) Communications References Product Manual

Model: SGD7W-□□□DA0B□□□

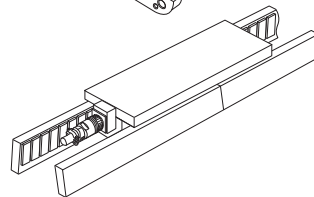
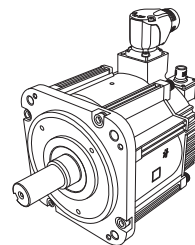
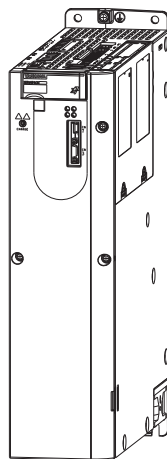

|   |    |
|---|----|
| Basic Information on SERVOPACKS                       | 1  |
| Selecting a SERVOPACK                                 | 2  |
| SERVOPACK Installation                                | 3  |
| Wiring and Connecting SERVOPACKS                      | 4  |
| Wiring and Settings for the Dynamic Brake             | 5  |
| Basic Functions That Require Setting before Operation | 6  |
| Application Functions                                 | 7  |
| Trial Operation and Actual Operation                  | 8  |
| Tuning  | 9  |
| Monitoring  | 10 |
| Safety Functions                                      | 11 |
| EtherCAT Communications                               | 12 |
| CiA402 Drive Profile                                  | 13 |
| Object Dictionary                                     | 14 |
| Maintenance   | 15 |
| Parameter and Object Lists                            | 16 |
| Appendices  | 17 |

Copyright © 2016 YASKAWA ELECTRIC CORPORATION

---

All rights reserved. No part of this publication may be reproduced, stored in a retrieval system, or transmitted, in any form, or by any means, mechanical, electronic, photocopying, recording, or otherwise, without the prior written permission of Yaskawa. No patent liability is assumed with respect to the use of the information contained herein. Moreover, because Yaskawa is constantly striving to improve its high-quality products, the information contained in this manual is subject to change without notice. Every precaution has been taken in the preparation of this manual. Nevertheless, Yaskawa assumes no responsibility for errors or omissions. Neither is any liability assumed for damages resulting from the use of the information contained in this publication.

## About this Manual

This manual provides information required to select  $\Sigma$ -7W SERVOPACKs with EtherCAT Communications References for  $\Sigma$ -7-Series AC Servo Drives, and to design, perform trial operation of, tune, operate, and maintain the Servo Drives.

Read and understand this manual to ensure correct usage of the  $\Sigma$ -7-Series AC Servo Drives.

Keep this manual in a safe place so that it can be referred to whenever necessary.

## Outline of Manual

The contents of the chapters of this manual are described in the following table.

Refer to these chapters as required.

| Chapter | Chapter Title   | Contents   |
|---------|---|--|
| 1       | Basic Information on SERVOPACKs                       | Provides information required to select SERVOPACKs, such as SERVOPACK models and combinations with Servomotors.                            |
| 2       | Selecting a SERVOPACK                                 | Provides information required to select SERVOPACKs, such as specifications, block diagrams, dimensional drawings, and connection examples. |
| 3       | SERVOPACK Installation                                | Provides information on installing SERVOPACKs in the required locations.   |
| 4       | Wiring and Connecting SERVOPACKs                      | Provides information on wiring and connecting SERVOPACKs to power supplies and peripheral devices.   |
| 5       | Wiring and Settings for the Dynamic Brake             | Provides information about selecting the resistor, wiring, and parameter settings when using the dynamic brake.                            |
| 6       | Basic Functions That Require Setting before Operation | Describes the basic functions that must be set before you start Servo System operation. It also describes the setting methods.             |
| 7       | Application Functions                                 | Describes the application functions that you can set before you start Servo System operation. It also describes the setting methods.       |
| 8       | Trial Operation and Actual Operation                  | Provides information on the flow and procedures for trial operation and convenient functions to use during trial operation.                |
| 9       | Tuning  | Provides information on the flow of tuning, details on tuning functions, and related operating procedures.                                 |
| 10      | Monitoring  | Provides information on monitoring SERVOPACK product information and SERVOPACK status.   |
| 11      | Safety Functions                                      | Provides detailed information on the safety functions of the SERVOPACK.  |
| 12      | EtherCAT Communications                               | Provides basic information on EtherCAT communications.   |
| 13      | CiA402 Drive Profile                                  | Provides detailed information on the CiA402 drive profile.   |
| 14      | Object Dictionary                                     | Provides an overview and details on the object dictionary.   |
| 15      | Maintenance   | Provides information on the meaning of, causes of, and corrections for alarms and warnings.  |
| 16      | Parameter Lists                                       | Provides information on the parameters.  |
| 17      | Appendices  | Provides information on interpreting panel displays and tables of corresponding SERVOPACK and SigmaWin+ function names.                    |

# Related Documents

The relationships between the documents that are related to the Servo Drives are shown in the following figure. The numbers in the figure correspond to the numbers in the table on the following pages. Refer to these documents as required.

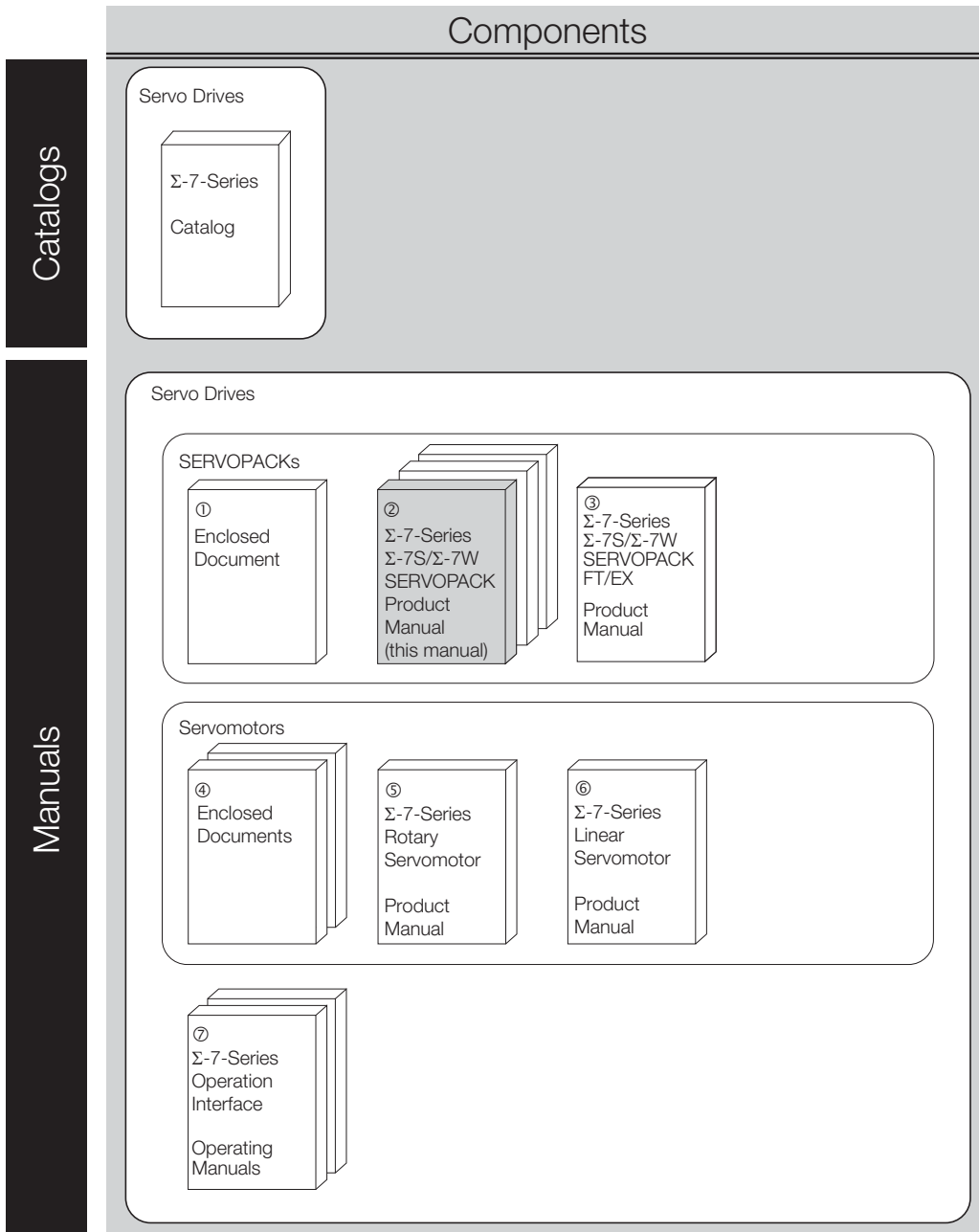



| Classification  | Document Name   | Document No.                  | Description   |
|---|---|-------------------------------|---|
| ①<br>Enclosed Document  | $\Sigma$ -7-Series AC Servo Drive $\Sigma$ -7S and $\Sigma$ -7W SERVOPACK with 400 V-Input Power Safety Precautions   | TOMP C710828 02               | Provides detailed information for the safe usage of $\Sigma$ -7-Series SERVOPACKs.  |
| ②<br>$\Sigma$ -7-Series $\Sigma$ -7S/ $\Sigma$ -7W SERVOPACK Product Manual       | $\Sigma$ -7-Series AC Servo Drive $\Sigma$ -7S SERVOPACK with 400 V-Input Power and EtherCAT (CoE) Communications References FT/EX Specification ZONE Outputs Product Manual                    | SIEP S800001 80               | Provide detailed information on selecting $\Sigma$ -7-Series SERVOPACKs and information on installing, connecting, setting, performing trial operation for, tuning, monitoring, and maintaining the Servo Drives. |
|   | $\Sigma$ -7-Series AC Servo Drive $\Sigma$ -7S SERVOPACK with 400-V Input Power and MECHATROLINK-III Communications References RJ-45 Connectors FT/EX Specification ZONE Outputs Product Manual | SIEP S8000002 14              |   |
|   | $\Sigma$ -7-Series AC Servo Drive $\Sigma$ -7W SERVOPACK with 400-V Input Power and EtherCAT (CoE) Communications References Product Manual   | This manual (SIEP S800002 19) |   |
|   | $\Sigma$ -7-Series AC Servo Drive $\Sigma$ -7W SERVOPACK with 400-V Input Power and MECHATROLINK-III Communications References RJ-45 Connectors Product Manual                                  | SIEP S800002 20               |   |
| ③<br>$\Sigma$ -7-Series $\Sigma$ -7S/ $\Sigma$ -7W SERVOPACK FT/EX Product Manual | $\Sigma$ -7-Series AC Servo Drive $\Sigma$ -7S SERVOPACK with 400-V Input Power and EtherCAT (CoE) Communications References FT/EX Specification for Advanced Safety Module Product Manual      | SIEP S800002 30               | Provide detailed information on the FT/EX Option for $\Sigma$ -7-Series SERVOPACKs.   |
| ④<br>Enclosed Documents   | AC Servo Drive Rotary Servomotor Safety Precautions   | TOBP C230260 00               | Provides detailed information for the safe usage of $\Sigma$ -7-Series Rotary Servomotors and Direct Drive Servomotors.   |
|   | AC Servomotor Linear $\Sigma$ Series Safety Precautions   | TOBP C230800 00               | Provides detailed information for the safe usage of $\Sigma$ -7-Series Linear Servomotors.  |
| ⑤<br>$\Sigma$ -7-Series Rotary Servomotor Product Manual                          | $\Sigma$ -7-Series AC Servo Drive Rotary Servomotor with 400 V-Input Power Product Manual   | SIEP S800001 86               | Provide detailed information on selecting, installing, and connecting the $\Sigma$ -7-Series Servomotors.   |
| ⑥<br>$\Sigma$ -7-Series Linear Servomotor Product Manual                          | $\Sigma$ -7-Series AC Servo Drive Linear Servomotor with 400 V-Input Power Product Manual   | SIEP S800001 81               |   |
| ⑦<br>$\Sigma$ -7-Series Operation Interface Operating Manuals                     | $\Sigma$ -7-Series AC Servo Drive Digital Operator Operating Manual   | SIEP S800001 33               | Describes the operating procedures for a Digital Operator for a $\Sigma$ -7-Series Servo System.  |
|   | AC Servo Drive Engineering Tool SigmaWin+ Operation Manual  | SIET S800001 34               | Provides detailed operating procedures for the SigmaWin+ Engineering Tool for a $\Sigma$ -7-Series Servo System.  |

# Using This Manual

## ◆ Technical Terms Used in This Manual

The following terms are used in this manual.

| Term  | Meaning   |
|---|---|
| Servomotor                                    | A $\Sigma$ -7-Series Rotary Servomotor or Linear Servomotor   |
| Rotary Servomotor                             | A $\Sigma$ -7-Series Rotary Servomotor (SGM7J, SGM7A, or SGM7G).  |
| Linear Servomotor                             | A $\Sigma$ -7-Series Linear Servomotor (SGLF or SGLT).  |
| SERVOPACK                                     | A $\Sigma$ -7-Series $\Sigma$ -7W servo amplifier with EtherCAT Communications References.  |
| Servo Drive                                   | The combination of a Servomotor and SERVOPACK.  |
| Servo System                                  | A servo control system that includes the combination of a Servo Drive with a host controller and peripheral devices.  |
| servo ON                                      | Supplying power to the motor.   |
| servo OFF                                     | Not supplying power to the motor.   |
| Servo ON command (Enable Operation command)   | A command that is used to turn ON the servo (i.e., supply power to the motor) when bit 3 of <i>control word</i> (6040h) is changed to 1 (ON) while the control power supply and main circuit power supply are ON.<br>Refer to the following section for details.<br> 13.1 Device Control (page 13-3)           |
| Servo OFF command (Disable Operation command) | A command that is used to turn OFF the servo (i.e., power not supplied to the motor) when bit 3 of <i>control word</i> (6040h) is changed to 0 (OFF) while the control power supply and main circuit power supply are ON.<br>Refer to the following section for details.<br> 13.1 Device Control (page 13-3) |
| base block (BB)                               | Shutting OFF the power supply to the motor by shutting OFF the base current to the power transistor in the SERVOPACK.   |
| servo lock                                    | A state in which the motor is stopped and is in a position loop with a position reference of 0.   |
| Main Circuit Cable                            | One of the cables that connect to the main circuit terminals, including the Main Circuit Power Supply Cable, Control Power Supply Cable, and Servomotor Main Circuit Cable.   |
| SigmaWin+                                     | The Engineering Tool for setting up and tuning Servo Drives or a computer in which the Engineering Tool is installed.   |

## ◆ Differences in Terms for Rotary Servomotors and Linear Servomotors

There are differences in the terms that are used for Rotary Servomotors and Linear Servomotors. This manual primarily describes Rotary Servomotors. If you are using a Linear Servomotor, you need to interpret the terms as given in the following table.

| Rotary Servomotors                    | Linear Servomotors                    |
|---------------------------------------|---------------------------------------|
| torque                                | force                                 |
| moment of inertia                     | mass                                  |
| rotation                              | movement                              |
| forward rotation and reverse rotation | forward movement and reverse movement |
| CW and CCW pulse trains               | forward and reverse pulse trains      |
| rotary encoder                        | linear encoder                        |
| absolute rotary encoder               | absolute linear encoder               |
| incremental rotary encoder            | incremental linear encoder            |
| unit: $\text{min}^{-1}$               | unit: mm/s                            |
| unit: N·m                             | unit: N                               |

## ◆ Notation Used in this Manual

### ■ Notation for Reverse Signals

The names of reverse signals (i.e., ones that are valid when low) are written with a forward slash (/) before the signal abbreviation.

Notation Example

$\overline{BK}$  is written as /BK.

### ■ Notation for Parameters

The notation depends on whether the parameter requires a numeric setting (parameter for numeric setting) or requires the selection of a function (parameter for selecting functions).

#### • Parameters for Numeric Settings

| Parameter number | The control methods for which the parameters apply are given. |              |                 |              |                |
|------------------|---|--------------|-----------------|--------------|----------------|
|                  | Speed   | Position     | Torque          |              |                |
| Pn100<br>(2100h) | Speed Loop Gain   |              |                 |              |                |
|                  | Setting Range   | Setting Unit | Default Setting | When Enabled | Classification |
|                  | 10 to 20,000  | 0.1 Hz       | 400             | Immediately  | Tuning         |

Object index number used to access the parameter with EtherCAT (CoE) communications

If [Common] is given here, the parameter applies to both axes A and B. If you change the setting, the new setting will be applied to both axes.

This is the minimum unit (setting increment) that you can set for the parameter.

This is the parameter setting before shipment.

This is when any change made to the parameter will become effective.

This is the parameter classification.

This is the setting range for the parameter.

#### • Parameters for Selecting Functions

| Parameter                  | Meaning                     | When Enabled  | Classification |
|----------------------------|-----------------------------|---------------|----------------|
| Pn00F<br>(200Fh)<br>Common | n.□□□0<br>(default setting) | After restart | Setup          |
|                            | n.□□□1                      |               |                |

Parameter number

Object index number used to access the parameter with EtherCAT (CoE) communications

The notation "n.□□□□" indicates a parameter for selecting functions. Each □ indicates the setting for one digit. The notation shown here means that the first digit from the right is set to 1.

This column explains the selections for the function.

If [Common] is given here, the parameter applies to both axes A and B. If you change the setting, the new setting will be applied to both axes.

## Notation Example

Notation Examples for Pn002

| n . 0 0 0 0 | Digit Notation |   | Numeric Value Notation |  |
|-------------|----------------|---|------------------------|--|
|             | Notation       | Meaning   | Notation               | Meaning  |
|             | Pn002 = n.□□□X | Indicates the first digit from the right in Pn002.  | Pn002 = n.□□□1         | Indicates that the first digit from the right in Pn002 is set to 1.  |
|             | Pn002 = n.□□X□ | Indicates the second digit from the right in Pn002. | Pn002 = n.□□1□         | Indicates that the second digit from the right in Pn002 is set to 1. |
|             | Pn002 = n.□X□□ | Indicates the third digit from the right in Pn002.  | Pn002 = n.□1□□         | Indicates that the third digit from the right in Pn002 is set to 1.  |
|             | Pn002 = n.X□□□ | Indicates the fourth digit from the right in Pn002. | Pn002 = n.1□□□         | Indicates that the fourth digit from the right in Pn002 is set to 1. |

## ◆ Engineering Tools Used in This Manual

This manual uses the interfaces of the SigmaWin+ for descriptions.

## ◆ Trademarks

- EtherCAT® is a registered trademark and patented technology, licensed by Beckhoff Automation GmbH, Germany.
- QR code is a trademark of Denso Wave Inc.
- Other product names and company names are the trademarks or registered trademarks of the respective company. “TM” and the ® mark do not appear with product or company names in this manual.

## ◆ Visual Aids

The following aids are used to indicate certain types of information for easier reference.



**Important** Indicates precautions or restrictions that must be observed. Also indicates alarm displays and other precautions that will not result in machine damage.



**Term** Indicates definitions of difficult terms or terms that have not been previously explained in this manual.

**Example** Indicates operating or setting examples.

**Information** Indicates supplemental information to deepen understanding or useful information.



---

# Safety Precautions

## ◆ Safety Information

To prevent personal injury and equipment damage in advance, the following signal words are used to indicate safety precautions in this document. The signal words are used to classify the hazards and the degree of damage or injury that may occur if a product is used incorrectly. Information marked as shown below is important for safety. Always read this information and heed the precautions that are provided.



### DANGER

- Indicates precautions that, if not heeded, are likely to result in loss of life, serious injury, or fire.



### WARNING

- Indicates precautions that, if not heeded, could result in loss of life, serious injury, or fire.



### CAUTION

- Indicates precautions that, if not heeded, could result in relatively serious or minor injury, or in fire.

### NOTICE

- Indicates precautions that, if not heeded, could result in property damage.

## ◆ Safety Precautions That Must Always Be Observed

### ■ General Precautions



## DANGER

- Read and understand this manual to ensure the safe usage of the product.
- Keep this manual in a safe, convenient place so that it can be referred to whenever necessary. Make sure that it is delivered to the final user of the product.
- Do not remove covers, cables, connectors, or optional devices while power is being supplied to the SERVOPACK.  
There is a risk of electric shock, operational failure of the product, or burning.



## WARNING

- Use a power supply with specifications (number of phases, voltage, frequency, and AC/DC type) that are appropriate for the product.  
There is a risk of burning, electric shock, or fire.
- Connect the ground terminals on the SERVOPACK and Servomotor to ground poles according to local electrical codes. (Connect to 10  $\Omega$  or less for the SERVOPACK.)  
There is a risk of electric shock or fire.
- Do not attempt to disassemble, repair, or modify the product.  
There is a risk of fire or failure.  
The warranty is void for the product if you disassemble, repair, or modify it.



## CAUTION

- The SERVOPACK heat sinks, regenerative resistors, Servomotors, and other components can be very hot while power is ON or soon after the power is turned OFF. Implement safety measures, such as installing covers, so that hands and parts such as cables do not come into contact with hot components.  
There is a risk of burn injury.
- For a 24-VDC power supply, use a power supply device with double insulation or reinforced insulation.  
There is a risk of electric shock.
- Do not damage, pull on, apply excessive force to, place heavy objects on, or pinch cables.  
There is a risk of failure, damage, or electric shock.
- The person who designs the system that uses the hard wire base block safety function must have a complete knowledge of the related safety standards and a complete understanding of the instructions in this document.  
There is a risk of injury, product damage, or machine damage.
- Do not use the product in an environment that is subject to water, corrosive gases, or flammable gases, or near flammable materials.  
There is a risk of electric shock or fire.

## NOTICE

- Do not attempt to use a SERVOPACK or Servomotor that is damaged or that has missing parts.
- Install external emergency stop circuits that shut OFF the power supply and stops operation immediately when an error occurs.
- In locations with poor power supply conditions, install the necessary protective devices (such as AC Reactors) to ensure that the input power is supplied within the specified voltage range. There is a risk of damage to the SERVOPACK.
- Use a Noise Filter to minimize the effects of electromagnetic interference. Electronic devices used near the SERVOPACK may be affected by electromagnetic interference.
- Always use a Servomotor and SERVOPACK in one of the specified combinations.
- Do not touch a SERVOPACK or Servomotor with wet hands. There is a risk of product failure.

### ■ Storage Precautions



## CAUTION

- Do not place an excessive load on the product during storage. (Follow all instructions on the packages.) There is a risk of injury or damage.

## NOTICE

- Do not install or store the product in any of the following locations.
  - Locations that are subject to direct sunlight
  - Locations that are subject to ambient temperatures that exceed product specifications
  - Locations that are subject to relative humidities that exceed product specifications
  - Locations that are subject to condensation as the result of extreme changes in temperature
  - Locations that are subject to corrosive or flammable gases
  - Locations that are near flammable materials
  - Locations that are subject to dust, salts, or iron powder
  - Locations that are subject to water, oil, or chemicals
  - Locations that are subject to vibration or shock that exceeds product specifications
  - Locations that are subject to radiationIf you store or install the product in any of the above locations, the product may fail or be damaged.

### ■ Transportation Precautions



## CAUTION

- Transport the product in a way that is suitable to the mass of the product.
- Do not use the eyebolts on a SERVOPACK or Servomotor to move the machine. There is a risk of damage or injury.
- When you handle a SERVOPACK or Servomotor, be careful of sharp parts, such as the corners. There is a risk of injury.
- Do not place an excessive load on the product during transportation. (Follow all instructions on the packages.) There is a risk of injury or damage.

## NOTICE

- Do not hold onto the front cover or connectors when you move a SERVOPACK.  
There is a risk of the SERVOPACK falling.
- A SERVOPACK or Servomotor is a precision device. Do not drop it or subject it to strong shock.  
There is a risk of failure or damage.
- Do not subject connectors to shock.  
There is a risk of faulty connections or damage.
- If disinfectants or insecticides must be used to treat packing materials such as wooden frames, plywood, or pallets, the packing materials must be treated before the product is packaged, and methods other than fumigation must be used.  
Example: Heat treatment, where materials are kiln-dried to a core temperature of 56°C for 30 minutes or more.  
If the electronic products, which include stand-alone products and products installed in machines, are packed with fumigated wooden materials, the electrical components may be greatly damaged by the gases or fumes resulting from the fumigation process. In particular, disinfectants containing halogen, which includes chlorine, fluorine, bromine, or iodine can contribute to the erosion of the capacitors.
- Do not overtighten the eyebolts on a SERVOPACK or Servomotor.  
If you use a tool to overtighten the eyebolts, the tapped holes may be damaged.

### ■ Installation Precautions



## CAUTION

- Install the Servomotor or SERVOPACK in a way that will support the mass given in technical documents.
- Install SERVOPACKs, Servomotors, regenerative resistors, and External Dynamic Brake Resistors on nonflammable materials.  
Installation directly onto or near flammable materials may result in fire.
- Provide the specified clearances between the SERVOPACK and the control panel as well as with other devices.  
There is a risk of fire or failure.
- Install the SERVOPACK in the specified orientation.  
There is a risk of fire or failure.
- Do not step on or place a heavy object on the product.  
There is a risk of failure, damage, or injury.
- Do not allow any foreign matter to enter the SERVOPACK or Servomotor.  
There is a risk of failure or fire.

## NOTICE

- **Do not install or store the product in any of the following locations.**
  - Locations that are subject to direct sunlight
  - Locations that are subject to ambient temperatures that exceed product specifications
  - Locations that are subject to relative humidities that exceed product specifications
  - Locations that are subject to condensation as the result of extreme changes in temperature
  - Locations that are subject to corrosive or flammable gases
  - Locations that are near flammable materials
  - Locations that are subject to dust, salts, or iron powder
  - Locations that are subject to water, oil, or chemicals
  - Locations that are subject to vibration or shock that exceeds product specifications
  - Locations that are subject to radiationIf you store or install the product in any of the above locations, the product may fail or be damaged.
- **Use the product in an environment that is appropriate for the product specifications.**

If you use the product in an environment that exceeds product specifications, the product may fail or be damaged.
- **A SERVOPACK or Servomotor is a precision device. Do not drop it or subject it to strong shock.**

There is a risk of failure or damage.
- **Always install a SERVOPACK in a control panel.**
- **Do not allow any foreign matter to enter a SERVOPACK or a Servomotor with a Cooling Fan and do not cover the outlet from the Servomotor's cooling fan.**

There is a risk of failure.

### ■ Wiring Precautions



## DANGER

- **Do not change any wiring while power is being supplied.**

There is a risk of electric shock or injury.



## WARNING

- **Wiring and inspections must be performed only by qualified engineers.**

There is a risk of electric shock or product failure.
- **Check all wiring and power supplies carefully.**

Incorrect wiring or incorrect voltage application to the output circuits may cause short-circuit failures. If a short-circuit failure occurs as a result of any of these causes, the holding brake will not work. This could damage the machine or cause an accident that may result in death or injury.
- **Connect the AC and DC power supplies to the specified SERVOPACK terminals.**
  - Connect an AC power supply to the L1, L2, and L3 terminals on the SERVOPACK.
  - Connect a DC power supply to the B1 and  $\ominus 2$  terminals and the 24 V and 0 V terminals on the SERVOPACK.

There is a risk of failure or fire.



## CAUTION

- Wait for six minutes after turning OFF the power supply and then make sure that the CHARGE indicator is not lit before starting wiring or inspection work. Do not touch the power supply terminals while the CHARGE lamp is lit after turning OFF the power supply because high voltage may still remain in the SERVOPACK.  
There is a risk of electric shock.
- Observe the precautions and instructions for wiring and trial operation precisely as described in this document.  
Failures caused by incorrect wiring or incorrect voltage application in the brake circuit may cause the SERVOPACK to fail, damage the equipment, or cause an accident resulting in death or injury.
- Check the wiring to be sure it has been performed correctly.  
Connectors and pin layouts are sometimes different for different models. Always confirm the pin layouts in technical documents for your model before operation.  
There is a risk of failure or malfunction.
- Connect wires to power supply terminals and motor connection terminals securely with the specified methods and tightening torque.  
Insufficient tightening may cause wires and terminal blocks to generate heat due to faulty contact, possibly resulting in fire.
- Use shielded twisted-pair cables or screened unshielded multi-twisted-pair cables for I/O Signal Cables and Encoder Cables.
- The maximum wiring length is 10 m for Control Power Supply Cables (+24 V, 0 V), 3 m for I/O Signal Cables, and 50 m for Encoder Cables or Servomotor Main Circuit Cables.
- Observe the following precautions when wiring the SERVOPACK's main circuit terminals.
  - Turn ON the power supply to the SERVOPACK only after all wiring, including the main circuit terminals, has been completed.
  - If a connector is used for the main circuit terminals, remove the main circuit connector from the SERVOPACK before you wire it.
  - Insert only one wire per insertion hole in the main circuit terminals.
  - When you insert a wire, make sure that the conductor wire (e.g., whiskers) does not come into contact with adjacent wires.
- Install molded-case circuit breakers and other safety measures to provide protection against short circuits in external wiring.  
There is a risk of fire or failure.

## NOTICE

- Whenever possible, use the Cables specified by Yaskawa.  
If you use any other cables, confirm the rated current and application environment of your model and use the wiring materials specified by Yaskawa or equivalent materials.
- Securely tighten connector screws and lock mechanisms.  
Insufficient tightening may result in connectors falling off during operation.
- Do not bundle power lines (e.g., the Main Circuit Cable) and low-current lines (e.g., the I/O Signal Cables or Encoder Cables) together or run them through the same duct. If you do not place power lines and low-current lines in separate ducts, separate them by at least 30 cm.  
If the cables are too close to each other, malfunctions may occur due to noise affecting the low-current lines.
- Install a battery at either the host controller or on the Encoder Cable.  
If you install batteries both at the host controller and on the Encoder Cable at the same time, you will create a loop circuit between the batteries, resulting in a risk of damage or burning.
- When connecting a battery, connect the polarity correctly.  
There is a risk of battery rupture or encoder failure.
- If you use an External Regenerative Resistor or External Dynamic Brake Resistor, use cable ties, clamps, or other means to secure the resistor so that the connectors or terminal blocks inside the SERVOPACK will not be affected even if the resistor is subjected to vibration or shock.  
There is a risk of SERVOPACK damage.

## ■ Operation Precautions



### WARNING

- **Before starting operation with a machine connected, change the settings of the switches and parameters to match the machine.**  
Unexpected machine operation, failure, or personal injury may occur if operation is started before appropriate settings are made.
- **Do not radically change the settings of the parameters.**  
There is a risk of unstable operation, machine damage, or injury.
- **Install limit switches or stoppers at the ends of the moving parts of the machine to prevent unexpected accidents.**  
There is a risk of machine damage or injury.
- **For trial operation, securely mount the Servomotor and disconnect it from the machine.**  
There is a risk of injury.
- **Forcing the motor to stop for overtravel is disabled when the Jog, Origin Search, or Easy FFT utility function is executed. Take necessary precautions.**  
There is a risk of machine damage or injury.
- **When an alarm occurs, the motor will coast to a stop or stop with the dynamic brake according to a setting in the SERVOPACK. The coasting distance will change with the moment of inertia of the load. Check the coasting distance during trial operation and implement suitable safety measures on the machine.**
- **Do not enter the machine's range of motion during operation.**  
There is a risk of injury.
- **Do not touch the moving parts of the Servomotor or machine during operation.**  
There is a risk of injury.



### CAUTION

- **Design the system to ensure safety even when problems, such as broken signal lines, occur.**  
For example, the P-OT and N-OT signals are set in the default settings to operate on the safe side if a signal line breaks. Do not change the polarity of this type of signal.
- **When overtravel occurs, the power supply to the motor is turned OFF and the brake is released.**  
If you use the Servomotor to drive a vertical load, set the Servomotor to enter a zero-clamped state after the Servomotor stops. Also, install safety devices (such as an external brake or counterweight) to prevent the moving parts of the machine from falling.
- **Always turn OFF the servo before you turn OFF the power supply. If you turn OFF the main circuit power supply or control power supply during operation before you turn OFF the servo, the Servomotor will stop as follows:**
  - If you turn OFF the main circuit power supply during operation without turning OFF the servo, the Servomotor will stop abruptly with the dynamic brake or it will coast to a stop.
  - If you turn OFF the control power supply during operation without turning OFF the servo, the Servomotor will stop abruptly with the dynamic brake or it will coast to a stop. For details, refer to the manual for the SERVOPACK.
  - If you use an External Dynamic Brake Resistor, the Servomotor stopping method will be different from when the built-in Dynamic Brake Resistor is used. For details, refer to the product manual for your SERVOPACK.
- **Do not use the dynamic brake for any application other than an emergency stop.**  
There is a risk of failure due to rapid deterioration of elements in the SERVOPACK and the risk of unexpected operation, machine damage, burning, or injury.

## NOTICE

- When you adjust the gain during system commissioning, use a measuring instrument to monitor the torque waveform and speed waveform and confirm that there is no vibration.  
If a high gain causes vibration, the Servomotor will be damaged quickly.
- Do not frequently turn the power supply ON and OFF. After you have started actual operation, allow at least one hour between turning the power supply ON and OFF (as a guideline).  
Do not use the product in applications that require the power supply to be turned ON and OFF frequently.  
The elements in the SERVOPACK will deteriorate quickly.
- An alarm or warning may occur if communications are performed with the host controller while the SigmaWin+ or Digital Operator is operating.  
If an alarm or warning occurs, it may interrupt the current process and stop the system.
- After you complete trial operation of the machine and facilities, use the SigmaWin+ to back up the settings of the SERVOPACK parameters. You can use them to reset the parameters after SERVOPACK replacement.  
If you do not copy backed up parameter settings, normal operation may not be possible after a faulty SERVOPACK is replaced, possibly resulting in machine or equipment damage.

### ■ Maintenance and Inspection Precautions

## DANGER

- Do not change any wiring while power is being supplied.  
There is a risk of electric shock or injury.

## WARNING

- Wiring and inspections must be performed only by qualified engineers.  
There is a risk of electric shock or product failure.

## CAUTION

- Wait for six minutes after turning OFF the power supply and then make sure that the CHARGE indicator is not lit before starting wiring or inspection work. Do not touch the power supply terminals while the CHARGE lamp is lit after turning OFF the power supply because high voltage may still remain in the SERVOPACK.  
There is a risk of electric shock.
- Before you replace a SERVOPACK, back up the settings of the SERVOPACK parameters. Copy the backed up parameter settings to the new SERVOPACK and confirm that they were copied correctly.  
If you do not copy backed up parameter settings or if the copy operation is not completed normally, normal operation may not be possible, possibly resulting in machine or equipment damage.

## NOTICE

- Discharge all static electricity from your body before you operate any of the buttons or switches inside the front cover of the SERVOPACK.  
There is a risk of equipment damage.



## ■ Troubleshooting Precautions



### DANGER

- If the safety device (molded-case circuit breaker or fuse) installed in the power supply line operates, remove the cause before you supply power to the SERVOPACK again. If necessary, repair or replace the SERVOPACK, check the wiring, and remove the factor that caused the safety device to operate.

There is a risk of fire, electric shock, or injury.



### WARNING

- The product may suddenly start to operate when the power supply is recovered after a momentary power interruption. Design the machine to ensure human safety when operation restarts.

There is a risk of injury.



### CAUTION

- When an alarm occurs, remove the cause of the alarm and ensure safety. Then reset the alarm or turn the power supply OFF and ON again to restart operation.  
There is a risk of injury or machine damage.
- If the Servo ON signal is input to the SERVOPACK and an alarm is reset, the Servomotor may suddenly restart operation. Confirm that the servo is OFF and ensure safety before you reset an alarm.  
There is a risk of injury or machine damage.
- Always insert a Magnetic Contactor in the line between the main circuit power supply and the main circuit power supply terminals on the SERVOPACK so that the power supply can be shut OFF at the main circuit power supply.  
If a Magnetic Contactor is not connected when the SERVOPACK fails, a large current may flow, possibly resulting in fire.
- If an alarm occurs, shut OFF the main circuit power supply.  
There is a risk of fire due to a Regenerative Resistor overheating as the result of regenerative transistor failure.
- Install a ground fault detector against overloads and short-circuiting or install a molded-case circuit breaker combined with a ground fault detector.  
There is a risk of SERVOPACK failure or fire if a ground fault occurs.
- The holding brake on a Servomotor will not ensure safety if there is the possibility that an external force (including gravity) may move the current position and create a hazardous situation when power is interrupted or an error occurs. If an external force may cause movement, install an external braking mechanism that ensures safety.

## ■ Disposal Precautions

- Correctly discard the product as stipulated by regional, local, and municipal laws and regulations. Be sure to include these contents in all labelling and warning notifications on the final product as necessary.



---

## ■ General Precautions

- Figures provided in this document are typical examples or conceptual representations. There may be differences between them and actual wiring, circuits, and products.
- The products shown in illustrations in this document are sometimes shown without covers or protective guards. Always replace all covers and protective guards before you use the product.
- If you need a new copy of this document because it has been lost or damaged, contact your nearest Yaskawa representative or one of the offices listed on the back of this document.
- This document is subject to change without notice for product improvements, specifications changes, and improvements to the manual itself.  
We will update the document number of the document and issue revisions when changes are made.
- Any and all quality guarantees provided by Yaskawa are null and void if the customer modifies the product in any way. Yaskawa disavows any responsibility for damages or losses that are caused by modified products.

---

# Warranty

## ◆ Details of Warranty

### ■ Warranty Period

The warranty period for a product that was purchased (hereinafter called the “delivered product”) is one year from the time of delivery to the location specified by the customer or 18 months from the time of shipment from the Yaskawa factory, whichever is sooner.

### ■ Warranty Scope

Yaskawa shall replace or repair a defective product free of charge if a defect attributable to Yaskawa occurs during the above warranty period.

This warranty does not cover defects caused by the delivered product reaching the end of its service life and replacement of parts that require replacement or that have a limited service life.

This warranty does not cover failures that result from any of the following causes.

- Improper handling, abuse, or use in unsuitable conditions or in environments not described in product catalogs or manuals, or in any separately agreed-upon specifications
- Causes not attributable to the delivered product itself
- Modifications or repairs not performed by Yaskawa
- Use of the delivered product in a manner in which it was not originally intended
- Causes that were not foreseeable with the scientific and technological understanding at the time of shipment from Yaskawa
- Events for which Yaskawa is not responsible, such as natural or human-made disasters

## ◆ Limitations of Liability

- Yaskawa shall in no event be responsible for any damage or loss of opportunity to the customer that arises due to failure of the delivered product.
- Yaskawa shall not be responsible for any programs (including parameter settings) or the results of program execution of the programs provided by the user or by a third party for use with programmable Yaskawa products.
- The information described in product catalogs or manuals is provided for the purpose of the customer purchasing the appropriate product for the intended application. The use thereof does not guarantee that there are no infringements of intellectual property rights or other proprietary rights of Yaskawa or third parties, nor does it construe a license.
- Yaskawa shall not be responsible for any damage arising from infringements of intellectual property rights or other proprietary rights of third parties as a result of using the information described in catalogs or manuals.

---

## ◆ Suitability for Use

- It is the customer's responsibility to confirm conformity with any standards, codes, or regulations that apply if the Yaskawa product is used in combination with any other products.
- The customer must confirm that the Yaskawa product is suitable for the systems, machines, and equipment used by the customer.
- Consult with Yaskawa to determine whether use in the following applications is acceptable. If use in the application is acceptable, use the product with extra allowance in ratings and specifications, and provide safety measures to minimize hazards in the event of failure.
  - Outdoor use, use involving potential chemical contamination or electrical interference, or use in conditions or environments not described in product catalogs or manuals
  - Nuclear energy control systems, combustion systems, railroad systems, aviation systems, vehicle systems, medical equipment, amusement machines, and installations subject to separate industry or government regulations
  - Systems, machines, and equipment that may present a risk to life or property
  - Systems that require a high degree of reliability, such as systems that supply gas, water, or electricity, or systems that operate continuously 24 hours a day
  - Other systems that require a similar high degree of safety
- Never use the product for an application involving serious risk to life or property without first ensuring that the system is designed to secure the required level of safety with risk warnings and redundancy, and that the Yaskawa product is properly rated and installed.
- The circuit examples and other application examples described in product catalogs and manuals are for reference. Check the functionality and safety of the actual devices and equipment to be used before using the product.
- Read and understand all use prohibitions and precautions, and operate the Yaskawa product correctly to prevent accidental harm to third parties.

## ◆ Specifications Change

The names, specifications, appearance, and accessories of products in product catalogs and manuals may be changed at any time based on improvements and other reasons. The next editions of the revised catalogs or manuals will be published with updated code numbers. Consult with your Yaskawa representative to confirm the actual specifications before purchasing a product.

## Compliance with UL Standards, EU Directives, UK Regulations, and Other Safety Standards

Certification marks for the standards for which the product has been certified by certification bodies are shown on nameplate. Products that do not have the marks are not certified for the standards. Refer to the Servomotor manual for compliant standards of Servomotors.

### ◆ North American Safety Standards (UL)



| Product   | Model | North American Safety Standards (UL File No.) |
|-----------|-------|---|
| SERVOPACK | SGD7W | UL 61800-5-1 (E147823),<br>CSA C22.2 No.274   |

### ◆ European Directives



| Product   | Model | EU Directive                              | Harmonized Standards  |
|-----------|-------|---|---|
| SERVOPACK | SGD7W | Machinery Directive<br>2006/42/EC         | EN ISO 13849-1: 2015<br>EN IEC 62061<br>EN 61800-5-2  |
|           |       | EMC Directive<br>2014/30/EU               | EN 55011 Group 1, Class A<br>EN 61000-6-2<br>EN 61000-6-4<br>EN 61800-3 (Category C2, Second environment) |
|           |       | Low Voltage Directive<br>2014/35/EU       | EN 61800-5-1  |
|           |       | RoHS Directive<br>2011/65/EU (EU)2015/863 | EN IEC 63000  |

Note: 1. We declared the CE Marking based on the harmonized standards in the above table.

2. These products are for industrial use. In home environments, these products may cause electromagnetic interference and additional noise reduction measures may be necessary.

◆ UK Conformity Assessed (UKCA)



| Product   | Model | UK Regulations  | Designated Standards  |
|-----------|-------|---|---|
| SERVOPACK | SGD7W | Supply of Machinery (Safety) Regulations<br>S.I. 2008/1597  | EN ISO 13849-1: 2015<br>EN IEC 62061<br>EN 61800-5-2  |
|           |       | Electromagnetic Compatibility Regulations<br>S.I. 2016/1091   | EN 55011 Group 1, Class A<br>EN 61000-6-2<br>EN 61000-6-4<br>EN 61800-3 (Category C2, Second environment) |
|           |       | Electrical Equipment (Safety) Regulations<br>S.I. 2016/1101   | EN 61800-5-1  |
|           |       | Restriction of the Use of Certain Hazardous Substances in Electrical and Electronic Equipment Regulations<br>S.I. 2012/3032 | EN IEC 63000  |

Note: We declared the UKCA marking based on the designated standards in the above table.

◆ Safety Standards

| Product   | Model | Safety Standards      | Standards                                       |
|-----------|-------|-----------------------|---|
| SERVOPACK | SGD7W | Safety of Machinery   | EN ISO 13849-1: 2015<br>EN 60204-1              |
|           |       | Functional Safety     | EN 61508 series<br>EN IEC 62061<br>EN 61800-5-2 |
|           |       | Functional Safety EMC | EN 61326-3-1<br>EN 61000-6-7                    |

■ Safety Parameters

| Item   | Standards                | Performance Level                                    |  |
|--|--------------------------|--|--|
| Safety Integrity Level                         | EN 61508                 | SIL3   |  |
|  | EN IEC 62061             | maximum SIL 3  |  |
| Mission Time                                   | EN 61508                 | 10 years   | 20 years   |
| Probability of Dangerous Failure per Hour      | EN 61508<br>EN IEC 62061 | PFH = $8.64 \times 10^{-9}$ [1/h]<br>(8.64% of SIL3) | PFH = $8.67 \times 10^{-9}$ [1/h]<br>(8.67% of SIL3) |
| Performance Level                              | EN ISO 13849-1           | PLe (Category 3)                                     |  |
| Mean Time to Dangerous Failure of Each Channel | EN ISO 13849-1           | MTTFd: High  |  |
| Average Diagnostic Coverage                    | EN ISO 13849-1           | DCavg: Medium  |  |
| Stop Category                                  | EN 60204-1               | Stop category 0                                      |  |
| Safety Function                                | EN 61800-5-2             | STO  |  |
| Hardware Fault Tolerance                       | EN 61508                 | HFT = 1  |  |
| Subsystem                                      | EN 61508                 | B  |  |

# Contents

|  |     |
|--|-----|
| About this Manual . . . . .  | iii |
| Outline of Manual . . . . .  | iii |
| Related Documents . . . . .  | iv  |
| Using This Manual . . . . .  | vi  |
| Safety Precautions . . . . .   | ix  |
| Warranty . . . . .   | xix |
| Compliance with UL Standards, EU Directives, UK Regulations,<br>and Other Safety Standards . . . . . | xxi |

## 1

### Basic Information on SERVOPACKs

|            |   |             |
|------------|---|-------------|
| <b>1.1</b> | <b>The <math>\Sigma</math>-7 Series . . . . .</b>                     | <b>1-3</b>  |
| <b>1.2</b> | <b>Introduction to EtherCAT . . . . .</b>                             | <b>1-4</b>  |
| 1.2.1      | Introduction to CANopen . . . . .                                     | 1-4         |
| 1.2.2      | CANopen over EtherCAT OSI Model . . . . .                             | 1-4         |
| 1.2.3      | Sending and Receiving Data in EtherCAT (CoE) Communications . . . . . | 1-5         |
| 1.2.4      | CoE Terminology . . . . .   | 1-5         |
| 1.2.5      | Data Types . . . . .  | 1-6         |
| 1.2.6      | Data Ranges . . . . .   | 1-6         |
| 1.2.7      | Object Numbers for Each Axis . . . . .                                | 1-7         |
| <b>1.3</b> | <b>Interpreting the Nameplate . . . . .</b>                           | <b>1-8</b>  |
| <b>1.4</b> | <b>Part Names . . . . .</b>   | <b>1-9</b>  |
| <b>1.5</b> | <b>Model Designations . . . . .</b>                                   | <b>1-11</b> |
| 1.5.1      | Interpreting SERVOPACK Model Numbers . . . . .                        | 1-11        |
| 1.5.2      | Interpreting Servomotor Model Numbers . . . . .                       | 1-12        |
| <b>1.6</b> | <b>Combinations of SERVOPACKs and Servomotors . . . . .</b>           | <b>1-13</b> |
| 1.6.1      | Combinations of Rotary Servomotors and SERVOPACKs . . . . .           | 1-13        |
| 1.6.2      | Combinations of Linear Servomotors and SERVOPACKs . . . . .           | 1-13        |
| <b>1.7</b> | <b>Functions . . . . .</b>  | <b>1-14</b> |
| <b>1.8</b> | <b>EtherCAT Communications LED Indicators . . . . .</b>               | <b>1-17</b> |
| 1.8.1      | RUN . . . . .   | 1-17        |
| 1.8.2      | ERR . . . . .   | 1-18        |
| 1.8.3      | Link/Activity . . . . .   | 1-18        |

## 2

### Selecting a SERVOPACK

|            |   |            |
|------------|---|------------|
| <b>2.1</b> | <b>Ratings and Specifications . . . . .</b>             | <b>2-2</b> |
| 2.1.1      | Ratings . . . . .                                       | 2-2        |
| 2.1.2      | SERVOPACK Overload Protection Characteristics . . . . . | 2-3        |
| 2.1.3      | Specifications . . . . .                                | 2-4        |

|            |   |             |
|------------|---|-------------|
| <b>2.2</b> | <b>Block Diagrams</b> . . . . .   | <b>2-8</b>  |
| 2.2.1      | SERVOPACKs without Built-in Servomotor Brake Control . . . . .                        | 2-8         |
| 2.2.2      | SERVOPACKs with Built-in Servomotor Brake Control . . . . .                           | 2-9         |
| <b>2.3</b> | <b>External Dimensions</b> . . . . .  | <b>2-10</b> |
| 2.3.1      | Front Cover Dimensions and Connector Specifications . . . . .                         | 2-10        |
| 2.3.2      | SERVOPACK External Dimensions . . . . .   | 2-11        |
| <b>2.4</b> | <b>Examples of Standard Connections between SERVOPACKs and Peripheral Devices</b> . . | <b>2-12</b> |

### 3

## SERVOPACK Installation

|            |   |            |
|------------|---|------------|
| <b>3.1</b> | <b>Installation Precautions</b> . . . . .                       | <b>3-2</b> |
| <b>3.2</b> | <b>Mounting Types and Orientation</b> . . . . .                 | <b>3-3</b> |
| <b>3.3</b> | <b>Mounting Hole Dimensions</b> . . . . .                       | <b>3-4</b> |
| <b>3.4</b> | <b>Mounting Interval</b> . . . . .                              | <b>3-5</b> |
| 3.4.1      | Installing One SERVOPACK in a Control Panel . . . . .           | 3-5        |
| 3.4.2      | Installing More Than One SERVOPACK in a Control Panel . . . . . | 3-5        |
| <b>3.5</b> | <b>Monitoring the Installation Environment</b> . . . . .        | <b>3-6</b> |
| <b>3.6</b> | <b>Derating Specifications</b> . . . . .                        | <b>3-7</b> |
| <b>3.7</b> | <b>EMC Installation Conditions</b> . . . . .                    | <b>3-8</b> |

### 4

## Wiring and Connecting SERVOPACKs

|            |   |             |
|------------|---|-------------|
| <b>4.1</b> | <b>Wiring and Connecting SERVOPACKs</b> . . . . .               | <b>4-3</b>  |
| 4.1.1      | General Precautions . . . . .                                   | 4-3         |
| 4.1.2      | Countermeasures against Noise . . . . .                         | 4-5         |
| 4.1.3      | Grounding . . . . .   | 4-8         |
| <b>4.2</b> | <b>Basic Wiring Diagrams</b> . . . . .                          | <b>4-9</b>  |
| <b>4.3</b> | <b>Wiring the Power Supply to the SERVOPACK</b> . . . . .       | <b>4-11</b> |
| 4.3.1      | Terminal Symbols and Terminal Names . . . . .                   | 4-11        |
| 4.3.2      | Wiring Procedure for Main Circuit Connector . . . . .           | 4-13        |
| 4.3.3      | Power ON Sequence . . . . .                                     | 4-14        |
| 4.3.4      | Power Supply Wiring Diagrams . . . . .                          | 4-15        |
| 4.3.5      | Wiring Regenerative Resistors . . . . .                         | 4-17        |
| 4.3.6      | Wiring Reactors for Harmonic Suppression . . . . .              | 4-18        |
| <b>4.4</b> | <b>Wiring Servomotors</b> . . . . .                             | <b>4-19</b> |
| 4.4.1      | Terminal Symbols and Terminal Names . . . . .                   | 4-19        |
| 4.4.2      | Pin Arrangement of Encoder Connectors (CN2A and CN2B) . . . . . | 4-19        |
| 4.4.3      | Wiring the SERVOPACK to the Encoder . . . . .                   | 4-20        |
| 4.4.4      | Wiring the SERVOPACK to the Holding Brake . . . . .             | 4-33        |



|            |  |             |
|------------|--|-------------|
| <b>4.5</b> | <b>Connecting I/O Signals</b> . . . . .                          | <b>4-36</b> |
| 4.5.1      | I/O Signal Connector (CN1) Names and Functions . . . . .         | 4-36        |
| 4.5.2      | I/O Signal Connector (CN1) Pin Arrangement . . . . .             | 4-38        |
| 4.5.3      | I/O Signal Wiring Examples . . . . .                             | 4-39        |
| 4.5.4      | I/O Circuits . . . . .   | 4-41        |
| <b>4.6</b> | <b>Connecting Safety Function Signals</b> . . . . .              | <b>4-43</b> |
| 4.6.1      | Pin Arrangement of Safety Function Signals (CN8A/CN8B) . . . . . | 4-43        |
| 4.6.2      | I/O Circuits . . . . .   | 4-44        |
| <b>4.7</b> | <b>Connecting EtherCAT Communications Cables</b> . . . . .       | <b>4-46</b> |
| 4.7.1      | EtherCAT Connectors (RJ45) . . . . .                             | 4-46        |
| 4.7.2      | Ethernet Communications Cables . . . . .                         | 4-47        |
| <b>4.8</b> | <b>Connecting the Other Connectors</b> . . . . .                 | <b>4-48</b> |
| 4.8.1      | Serial Communications Connector (CN3) . . . . .                  | 4-48        |
| 4.8.2      | Computer Connector (CN7) . . . . .                               | 4-48        |
| 4.8.3      | Analog Monitor Connector (CN5) . . . . .                         | 4-48        |

## 5

### Wiring and Settings for the Dynamic Brake

|            |  |             |
|------------|--|-------------|
| <b>5.1</b> | <b>Introduction to the Dynamic Brake</b> . . . . .                                       | <b>5-2</b>  |
| <b>5.2</b> | <b>Using the Dynamic Brake</b> . . . . .   | <b>5-3</b>  |
| 5.2.1      | Using the Dynamic Brake . . . . .  | 5-3         |
| 5.2.2      | Selecting the Dynamic Brake Resistor . . . . .   | 5-4         |
| 5.2.3      | Connecting Dynamic Brake Resistors . . . . .   | 5-7         |
| 5.2.4      | Setting the Energy Consumption and Resistance of<br>the Dynamic Brake Resistor . . . . . | 5-9         |
| <b>5.3</b> | <b>Coasting Distances for Dynamic Braking</b> . . . . .                                  | <b>5-10</b> |
| 5.3.1      | Coasting Distance during Dynamic Braking . . . . .                                       | 5-10        |
| 5.3.2      | Data for Calculating Coasting Distance . . . . .   | 5-11        |

## 6

### Basic Functions That Require Setting before Operation

|            |  |             |
|------------|--|-------------|
| <b>6.1</b> | <b>Manipulating SERVOPACK Parameters (Pn□□□)</b> . . . . .       | <b>6-3</b>  |
| 6.1.1      | Classifications of SERVOPACK Parameters . . . . .                | 6-3         |
| 6.1.2      | Notation for SERVOPACK Parameters . . . . .                      | 6-4         |
| 6.1.3      | SERVOPACK Parameter Setting Methods . . . . .                    | 6-5         |
| 6.1.4      | Write Prohibition Setting for SERVOPACK Parameters . . . . .     | 6-6         |
| 6.1.5      | Initializing SERVOPACK Parameter Settings . . . . .              | 6-9         |
| <b>6.2</b> | <b>Power Supply Type Settings for the Main Circuit</b> . . . . . | <b>6-11</b> |
| <b>6.3</b> | <b>Automatic Detection of Connected Motor</b> . . . . .          | <b>6-12</b> |
| <b>6.4</b> | <b>Motor Direction Setting</b> . . . . .                         | <b>6-13</b> |
| <b>6.5</b> | <b>Setting the Linear Encoder Pitch</b> . . . . .                | <b>6-14</b> |
| <b>6.6</b> | <b>Writing Linear Servomotor Parameters</b> . . . . .            | <b>6-15</b> |

|             |  |             |
|-------------|--|-------------|
| <b>6.7</b>  | <b>Selecting the Phase Sequence for a Linear Servomotor . . . . .</b>                            | <b>6-19</b> |
| <b>6.8</b>  | <b>Polarity Sensor Setting . . . . .</b>   | <b>6-21</b> |
| <b>6.9</b>  | <b>Polarity Detection . . . . .</b>  | <b>6-22</b> |
| 6.9.1       | Restrictions . . . . .   | 6-22        |
| 6.9.2       | Using the Servo ON Command (Enable Operation Command)<br>to Perform Polarity Detection . . . . . | 6-23        |
| 6.9.3       | Using a Tool Function to Perform Polarity Detection . . . . .                                    | 6-24        |
| <b>6.10</b> | <b>Overtravel and Related Settings . . . . .</b>   | <b>6-25</b> |
| 6.10.1      | Overtravel Signals . . . . .   | 6-25        |
| 6.10.2      | Setting to Enable/Disable Overtravel . . . . .   | 6-26        |
| 6.10.3      | Motor Stopping Method for Overtravel . . . . .   | 6-26        |
| 6.10.4      | Overtravel Warnings . . . . .  | 6-28        |
| 6.10.5      | Overtravel Release Method Selection . . . . .  | 6-29        |
| 6.10.6      | Overtravel Status . . . . .  | 6-30        |
| 6.10.7      | Overtravel Operation by Mode . . . . .   | 6-30        |
| <b>6.11</b> | <b>Holding Brake . . . . .</b>   | <b>6-31</b> |
| 6.11.1      | Brake Operating Sequence . . . . .   | 6-31        |
| 6.11.2      | /BK (Brake) Signal . . . . .   | 6-32        |
| 6.11.3      | Output Timing of /BK (Brake) Signal When the Servomotor Is Stopped . . . . .                     | 6-33        |
| 6.11.4      | Output Timing of /BK (Brake) Signal When the Servomotor Is Operating . . . . .                   | 6-33        |
| 6.11.5      | Built-in Brake Relay Usage Selection . . . . .   | 6-35        |
| <b>6.12</b> | <b>Motor Stopping Methods for Servo OFF and Alarms . . . . .</b>                                 | <b>6-36</b> |
| 6.12.1      | Stopping Method for Servo OFF . . . . .  | 6-37        |
| 6.12.2      | Servomotor Stopping Method for Alarms . . . . .  | 6-37        |
| <b>6.13</b> | <b>Motor Overload Detection Level . . . . .</b>  | <b>6-39</b> |
| 6.13.1      | Detection Timing for Overload Warnings (A.910) . . . . .   | 6-39        |
| 6.13.2      | Detection Timing for Overload Alarms (A.720) . . . . .   | 6-40        |
| <b>6.14</b> | <b>Setting Unit Systems . . . . .</b>  | <b>6-41</b> |
| 6.14.1      | Setting the Position Reference Unit . . . . .  | 6-41        |
| 6.14.2      | Setting the Speed Reference Unit . . . . .   | 6-46        |
| 6.14.3      | Setting the Acceleration Reference Unit . . . . .  | 6-47        |
| 6.14.4      | Setting the Torque Reference Unit . . . . .  | 6-47        |
| 6.14.5      | Setting the Encoder Resolution . . . . .   | 6-47        |
| <b>6.15</b> | <b>Resetting the Absolute Encoder . . . . .</b>  | <b>6-48</b> |
| 6.15.1      | Precautions on Resetting . . . . .   | 6-48        |
| 6.15.2      | Preparations . . . . .   | 6-48        |
| 6.15.3      | Applicable Tools . . . . .   | 6-48        |
| 6.15.4      | Operating Procedure . . . . .  | 6-49        |
| <b>6.16</b> | <b>Setting the Origin of the Absolute Encoder . . . . .</b>                                      | <b>6-51</b> |
| 6.16.1      | Absolute Encoder Origin Offset . . . . .   | 6-51        |
| 6.16.2      | Setting the Origin of the Absolute Linear Encoder . . . . .                                      | 6-51        |
| <b>6.17</b> | <b>Setting the Regenerative Resistor Capacity . . . . .</b>                                      | <b>6-54</b> |

# 7

## Application Functions

|             |   |             |
|-------------|---|-------------|
| <b>7.1</b>  | <b>I/O Signal Allocations</b>                                 | <b>7-3</b>  |
| 7.1.1       | Input Signal Allocations                                      | 7-4         |
| 7.1.2       | Output Signal Allocations                                     | 7-7         |
| 7.1.3       | ALM (Servo Alarm) Signal                                      | 7-10        |
| 7.1.4       | /WARN (Warning) Signal  | 7-10        |
| 7.1.5       | /TGON (Rotation Detection) Signal                             | 7-11        |
| 7.1.6       | /S-RDY (Servo Ready) Signal                                   | 7-12        |
| 7.1.7       | /V-CMP (Speed Coincidence Detection) Signal                   | 7-12        |
| 7.1.8       | /COIN (Positioning Completion) Signal                         | 7-14        |
| 7.1.9       | /NEAR (Near) Signal   | 7-15        |
| 7.1.10      | Speed Limit during Torque Control                             | 7-16        |
| <b>7.2</b>  | <b>Operation for Momentary Power Interruptions</b>            | <b>7-18</b> |
| <b>7.3</b>  | <b>SEMI F47 Function</b>                                      | <b>7-19</b> |
| <b>7.4</b>  | <b>Setting the Motor Maximum Speed</b>                        | <b>7-21</b> |
| <b>7.5</b>  | <b>Software Limits</b>  | <b>7-22</b> |
| <b>7.6</b>  | <b>Selecting Torque Limits</b>                                | <b>7-23</b> |
| 7.6.1       | Internal Torque Limits  | 7-23        |
| 7.6.2       | External Torque Limits  | 7-24        |
| 7.6.3       | /CLT (Torque Limit Detection) Signal                          | 7-27        |
| <b>7.7</b>  | <b>Absolute Encoders</b>                                      | <b>7-28</b> |
| 7.7.1       | Connecting an Absolute Encoder                                | 7-28        |
| 7.7.2       | Structure of the Position Data of the Absolute Encoder        | 7-28        |
| 7.7.3       | Multiturn Limit Setting                                       | 7-29        |
| 7.7.4       | Multiturn Limit Disagreement Alarm (A.CC0)                    | 7-31        |
| <b>7.8</b>  | <b>Absolute Linear Encoders</b>                               | <b>7-34</b> |
| 7.8.1       | Connecting an Absolute Linear Encoder                         | 7-34        |
| 7.8.2       | Structure of the Position Data of the Absolute Linear Encoder | 7-34        |
| <b>7.9</b>  | <b>Software Reset</b>   | <b>7-35</b> |
| 7.9.1       | Preparations  | 7-35        |
| 7.9.2       | Applicable Tools  | 7-35        |
| 7.9.3       | Operating Procedure   | 7-36        |
| <b>7.10</b> | <b>Initializing the Vibration Detection Level</b>             | <b>7-37</b> |
| 7.10.1      | Preparations  | 7-37        |
| 7.10.2      | Applicable Tools  | 7-38        |
| 7.10.3      | Operating Procedure   | 7-38        |
| 7.10.4      | Related Parameters  | 7-40        |
| <b>7.11</b> | <b>Adjusting the Motor Current Detection Signal Offset</b>    | <b>7-41</b> |
| 7.11.1      | Automatic Adjustment  | 7-41        |
| 7.11.2      | Manual Adjustment   | 7-43        |
| <b>7.12</b> | <b>Forcing the Motor to Stop</b>                              | <b>7-45</b> |
| 7.12.1      | FSTP (Forced Stop Input) Signal                               | 7-45        |
| 7.12.2      | Stopping Method Selection for Forced Stops                    | 7-45        |
| 7.12.3      | Resetting Method for Forced Stops                             | 7-47        |

|             |  |             |
|-------------|--|-------------|
| <b>7.13</b> | <b>Overheat Protection . . . . .</b>                           | <b>7-48</b> |
| 7.13.1      | Connecting the Overheat Protection Input (TH) Signal . . . . . | 7-48        |
| 7.13.2      | Overheat Protection Selections . . . . .                       | 7-49        |

## 8

### Trial Operation and Actual Operation

|            |   |             |
|------------|---|-------------|
| <b>8.1</b> | <b>Flow of Trial Operation . . . . .</b>                                      | <b>8-2</b>  |
| 8.1.1      | Flow of Trial Operation for Rotary Servomotors . . . . .                      | 8-2         |
| 8.1.2      | Flow of Trial Operation for Linear Servomotors . . . . .                      | 8-4         |
| <b>8.2</b> | <b>Inspections and Confirmations before Trial Operation . . . . .</b>         | <b>8-6</b>  |
| <b>8.3</b> | <b>Trial Operation for the Servomotor without a Load . . . . .</b>            | <b>8-7</b>  |
| 8.3.1      | Preparations . . . . .  | 8-7         |
| 8.3.2      | Applicable Tools . . . . .  | 8-8         |
| 8.3.3      | Operating Procedure . . . . .   | 8-8         |
| <b>8.4</b> | <b>Trial Operation with EtherCAT (CoE) Communications . . . . .</b>           | <b>8-10</b> |
| <b>8.5</b> | <b>Trial Operation with the Servomotor Connected to the Machine . . . . .</b> | <b>8-11</b> |
| 8.5.1      | Precautions . . . . .   | 8-11        |
| 8.5.2      | Preparations . . . . .  | 8-11        |
| 8.5.3      | Operating Procedure . . . . .   | 8-12        |
| <b>8.6</b> | <b>Convenient Function to Use during Trial Operation . . . . .</b>            | <b>8-13</b> |
| 8.6.1      | Program Jogging . . . . .   | 8-13        |
| 8.6.2      | Origin Search . . . . .   | 8-19        |
| 8.6.3      | Test without a Motor . . . . .  | 8-21        |

## 9

### Tuning

|            |   |             |
|------------|---|-------------|
| <b>9.1</b> | <b>Overview and Flow of Tuning . . . . .</b>                              | <b>9-4</b>  |
| 9.1.1      | Tuning Functions . . . . .  | 9-5         |
| 9.1.2      | Diagnostic Tool . . . . .   | 9-6         |
| <b>9.2</b> | <b>Monitoring Methods . . . . .</b>                                       | <b>9-7</b>  |
| <b>9.3</b> | <b>Precautions to Ensure Safe Tuning . . . . .</b>                        | <b>9-8</b>  |
| 9.3.1      | Overtravel Settings . . . . .   | 9-8         |
| 9.3.2      | Torque Limit Settings . . . . .   | 9-8         |
| 9.3.3      | Setting the Position Deviation Overflow Alarm Level . . . . .             | 9-8         |
| 9.3.4      | Vibration Detection Level Setting . . . . .                               | 9-10        |
| 9.3.5      | Setting the Position Deviation Overflow Alarm Level at Servo ON . . . . . | 9-10        |
| <b>9.4</b> | <b>Tuning-less Function . . . . .</b>                                     | <b>9-12</b> |
| 9.4.1      | Application Restrictions . . . . .  | 9-12        |
| 9.4.2      | Operating Procedure . . . . .   | 9-13        |
| 9.4.3      | Troubleshooting Alarms . . . . .  | 9-14        |
| 9.4.4      | Parameters Disabled by Tuning-less Function . . . . .                     | 9-15        |
| 9.4.5      | Automatically Adjusted Function Setting . . . . .                         | 9-15        |
| 9.4.6      | Related Parameters . . . . .  | 9-15        |

|             |   |             |
|-------------|---|-------------|
| <b>9.5</b>  | <b>Estimating the Moment of Inertia . . . . .</b>                                 | <b>9-16</b> |
| 9.5.1       | Outline . . . . .   | 9-16        |
| 9.5.2       | Restrictions . . . . .  | 9-16        |
| 9.5.3       | Applicable Tools . . . . .  | 9-17        |
| 9.5.4       | Operating Procedure . . . . .   | 9-17        |
| <b>9.6</b>  | <b>Autotuning without Host Reference . . . . .</b>                                | <b>9-24</b> |
| 9.6.1       | Outline . . . . .   | 9-24        |
| 9.6.2       | Restrictions . . . . .  | 9-25        |
| 9.6.3       | Applicable Tools . . . . .  | 9-26        |
| 9.6.4       | Operating Procedure . . . . .   | 9-26        |
| 9.6.5       | Troubleshooting Problems in Autotuning without a Host Reference . . . . .         | 9-30        |
| 9.6.6       | Automatically Adjusted Function Settings . . . . .                                | 9-32        |
| 9.6.7       | Related Parameters . . . . .  | 9-34        |
| <b>9.7</b>  | <b>Autotuning with a Host Reference . . . . .</b>                                 | <b>9-35</b> |
| 9.7.1       | Outline . . . . .   | 9-35        |
| 9.7.2       | Restrictions . . . . .  | 9-36        |
| 9.7.3       | Applicable Tools . . . . .  | 9-36        |
| 9.7.4       | Operating Procedure . . . . .   | 9-37        |
| 9.7.5       | Troubleshooting Problems in Autotuning with a Host Reference . . . . .            | 9-40        |
| 9.7.6       | Automatically Adjusted Function Settings . . . . .                                | 9-40        |
| 9.7.7       | Related Parameters . . . . .  | 9-41        |
| <b>9.8</b>  | <b>Custom Tuning . . . . .</b>  | <b>9-42</b> |
| 9.8.1       | Outline . . . . .   | 9-42        |
| 9.8.2       | Preparations . . . . .  | 9-42        |
| 9.8.3       | Applicable Tools . . . . .  | 9-43        |
| 9.8.4       | Operating Procedure . . . . .   | 9-43        |
| 9.8.5       | Automatically Adjusted Function Settings . . . . .                                | 9-48        |
| 9.8.6       | Tuning Example for Tuning Mode 2 or 3 . . . . .                                   | 9-48        |
| 9.8.7       | Related Parameters . . . . .  | 9-49        |
| <b>9.9</b>  | <b>Anti-Resonance Control Adjustment . . . . .</b>                                | <b>9-50</b> |
| 9.9.1       | Outline . . . . .   | 9-50        |
| 9.9.2       | Preparations . . . . .  | 9-50        |
| 9.9.3       | Applicable Tools . . . . .  | 9-51        |
| 9.9.4       | Operating Procedure . . . . .   | 9-51        |
| 9.9.5       | Related Parameters . . . . .  | 9-53        |
| 9.9.6       | Suppressing Different Vibration Frequencies with Anti-resonance Control . . . . . | 9-53        |
| <b>9.10</b> | <b>Vibration Suppression . . . . .</b>  | <b>9-55</b> |
| 9.10.1      | Outline . . . . .   | 9-55        |
| 9.10.2      | Preparations . . . . .  | 9-56        |
| 9.10.3      | Applicable Tools . . . . .  | 9-56        |
| 9.10.4      | Operating Procedure . . . . .   | 9-56        |
| 9.10.5      | Setting Combined Functions . . . . .  | 9-58        |
| 9.10.6      | Related Parameters . . . . .  | 9-58        |
| <b>9.11</b> | <b>Speed Ripple Compensation . . . . .</b>  | <b>9-59</b> |
| 9.11.1      | Outline . . . . .   | 9-59        |
| 9.11.2      | Setting Up Speed Ripple Compensation . . . . .                                    | 9-59        |
| 9.11.3      | Setting Parameters . . . . .  | 9-63        |

|             |  |             |
|-------------|--|-------------|
| <b>9.12</b> | <b>Additional Adjustment Functions . . . . .</b> | <b>9-65</b> |
| 9.12.1      | Gain Switching . . . . .                         | 9-65        |
| 9.12.2      | Friction Compensation . . . . .                  | 9-68        |
| 9.12.3      | Gravity Compensation . . . . .                   | 9-69        |
| 9.12.4      | Current Control Mode Selection . . . . .         | 9-70        |
| 9.12.5      | Current Gain Level Setting . . . . .             | 9-71        |
| 9.12.6      | Speed Detection Method Selection . . . . .       | 9-71        |
| 9.12.7      | Speed Feedback Filter . . . . .                  | 9-71        |
| 9.12.8      | Backlash Compensation . . . . .                  | 9-72        |
| <b>9.13</b> | <b>Manual Tuning . . . . .</b>                   | <b>9-77</b> |
| 9.13.1      | Tuning the Servo Gains . . . . .                 | 9-77        |
| 9.13.2      | Compatible Adjustment Functions . . . . .        | 9-87        |
| <b>9.14</b> | <b>Diagnostic Tools . . . . .</b>                | <b>9-91</b> |
| 9.14.1      | Mechanical Analysis . . . . .                    | 9-91        |
| 9.14.2      | Easy FFT . . . . .                               | 9-93        |

## 10 Monitoring

|             |   |              |
|-------------|---|--------------|
| <b>10.1</b> | <b>Monitoring Product Information . . . . .</b>                     | <b>10-2</b>  |
| 10.1.1      | Items That You Can Monitor . . . . .                                | 10-2         |
| 10.1.2      | Operating Procedures . . . . .                                      | 10-2         |
| <b>10.2</b> | <b>Monitoring SERVOPACK Status . . . . .</b>                        | <b>10-3</b>  |
| 10.2.1      | Servo Drive Status . . . . .  | 10-3         |
| 10.2.2      | Monitoring Operation, Status, and I/O . . . . .                     | 10-3         |
| 10.2.3      | I/O Signals Status Monitor . . . . .                                | 10-5         |
| <b>10.3</b> | <b>Monitoring Machine Operation Status and Signal Waveforms . .</b> | <b>10-7</b>  |
| 10.3.1      | Items That You Can Monitor . . . . .                                | 10-7         |
| 10.3.2      | Using the SigmaWin+ . . . . .                                       | 10-8         |
| 10.3.3      | Using a Measuring Instrument . . . . .                              | 10-9         |
| <b>10.4</b> | <b>Monitoring Product Life . . . . .</b>                            | <b>10-14</b> |
| 10.4.1      | Items That You Can Monitor . . . . .                                | 10-14        |
| 10.4.2      | Operating Procedure . . . . .                                       | 10-15        |
| 10.4.3      | Preventative Maintenance . . . . .                                  | 10-15        |
| <b>10.5</b> | <b>Alarm Tracing . . . . .</b>                                      | <b>10-17</b> |
| 10.5.1      | Data for Which Alarm Tracing Is Performed . . . . .                 | 10-17        |
| 10.5.2      | Applicable Tools . . . . .  | 10-17        |

## 11 Safety Functions

|             |   |             |
|-------------|---|-------------|
| <b>11.1</b> | <b>Introduction to the Safety Functions . . . . .</b> | <b>11-3</b> |
| 11.1.1      | Safety Functions . . . . .                            | 11-3        |
| 11.1.2      | Precautions for Safety Functions . . . . .            | 11-4        |

|             |   |              |
|-------------|---|--------------|
| <b>11.2</b> | <b>Hard Wire Base Block (HWBB and SBB)</b>        | <b>11-5</b>  |
| 11.2.1      | Risk Assessment                                   | 11-6         |
| 11.2.2      | Hard Wire Base Block (HWBB) State                 | 11-7         |
| 11.2.3      | Resetting the HWBB State                          | 11-8         |
| 11.2.4      | Recovery Method                                   | 11-9         |
| 11.2.5      | Detecting Errors in HWBB Signal                   | 11-9         |
| 11.2.6      | HWBB Input Signal Specifications                  | 11-10        |
| 11.2.7      | Operation without a Host Controller               | 11-10        |
| 11.2.8      | /S-RDY (Servo Ready Output) Signal                | 11-11        |
| 11.2.9      | /BK (Brake Output) Signal                         | 11-11        |
| 11.2.10     | Stopping Methods                                  | 11-12        |
| 11.2.11     | ALM (Servo Alarm) Signal                          | 11-12        |
| <b>11.3</b> | <b>EDM_A and EDM_B (External Device Monitors)</b> | <b>11-13</b> |
| 11.3.1      | EDM_A Output Signal Specifications                | 11-13        |
| <b>11.4</b> | <b>Applications Examples for Safety Functions</b> | <b>11-14</b> |
| 11.4.1      | Connection Example                                | 11-14        |
| 11.4.2      | Failure Detection Method                          | 11-14        |
| 11.4.3      | Procedure   | 11-15        |
| <b>11.5</b> | <b>Validating Safety Functions</b>                | <b>11-16</b> |
| <b>11.6</b> | <b>Connecting a Safety Function Device</b>        | <b>11-17</b> |
| <b>11.7</b> | <b>Safety Module Safety Functions</b>             | <b>11-18</b> |
| 11.7.1      | Safety Base Block with Delay (SBB-D)              | 11-18        |
| 11.7.2      | Safe Position Monitor with Delay (SPM-D)          | 11-19        |
| 11.7.3      | Safe Speed Limit with Delay (SLS-D)               | 11-20        |
| 11.7.4      | Active Mode Function                              | 11-20        |

# 12

## EtherCAT Communications

|             |  |              |
|-------------|--|--------------|
| <b>12.1</b> | <b>EtherCAT Slave Information</b>              | <b>12-2</b>  |
| <b>12.2</b> | <b>EtherCAT State Machine</b>                  | <b>12-3</b>  |
| <b>12.3</b> | <b>EtherCAT (CoE) Communications Settings</b>  | <b>12-5</b>  |
| 12.3.1      | Normal Device Recognition Process at Startup   | 12-5         |
| 12.3.2      | Application Example                            | 12-5         |
| 12.3.3      | Device Recognition with Station Aliases        | 12-5         |
| <b>12.4</b> | <b>PDO Mappings</b>                            | <b>12-6</b>  |
| 12.4.1      | Setting Procedure for PDO Mappings             | 12-7         |
| 12.4.2      | Default PDO Mappings                           | 12-7         |
| <b>12.5</b> | <b>Synchronization with Distributed Clocks</b> | <b>12-8</b>  |
| <b>12.6</b> | <b>Emergency Messages</b>                      | <b>12-11</b> |

# 13

## CiA402 Drive Profile

|             |  |              |
|-------------|--|--------------|
| <b>13.1</b> | <b>Device Control</b> . . . . .                            | <b>13-3</b>  |
| 13.1.1      | State Machine Control Commands . . . . .                   | 13-4         |
| 13.1.2      | Bits in Status word . . . . .                              | 13-4         |
| 13.1.3      | Related Objects . . . . .                                  | 13-4         |
| <b>13.2</b> | <b>Modes of Operation</b> . . . . .                        | <b>13-5</b>  |
| 13.2.1      | Related Objects . . . . .                                  | 13-5         |
| 13.2.2      | Dynamic Mode Changes . . . . .                             | 13-5         |
| <b>13.3</b> | <b>Position Control Modes</b> . . . . .                    | <b>13-6</b>  |
| 13.3.1      | Profile Position Mode . . . . .                            | 13-6         |
| 13.3.2      | Interpolated Position Mode . . . . .                       | 13-9         |
| 13.3.3      | Cyclic Synchronous Position Mode . . . . .                 | 13-12        |
| <b>13.4</b> | <b>Homing</b> . . . . .                                    | <b>13-14</b> |
| 13.4.1      | Related Objects . . . . .                                  | 13-14        |
| 13.4.2      | Homing Method . . . . .                                    | 13-14        |
| <b>13.5</b> | <b>Velocity Control Modes</b> . . . . .                    | <b>13-17</b> |
| 13.5.1      | Profile Velocity Mode . . . . .                            | 13-17        |
| 13.5.2      | Cyclic Synchronous Velocity Mode . . . . .                 | 13-18        |
| <b>13.6</b> | <b>Torque Control Modes</b> . . . . .                      | <b>13-19</b> |
| 13.6.1      | Profile Torque Mode . . . . .                              | 13-19        |
| 13.6.2      | Cyclic Sync Torque Mode . . . . .                          | 13-20        |
| <b>13.7</b> | <b>Torque Limits</b> . . . . .                             | <b>13-21</b> |
| <b>13.8</b> | <b>Digital I/O Signals</b> . . . . .                       | <b>13-22</b> |
| <b>13.9</b> | <b>Touch Probe</b> . . . . .                               | <b>13-23</b> |
| 13.9.1      | Related Objects . . . . .                                  | 13-23        |
| 13.9.2      | Example of Execution Procedure for a Touch Probe . . . . . | 13-24        |

# 14

## Object Dictionary

|             |  |              |
|-------------|--|--------------|
| <b>14.1</b> | <b>Object Dictionary List</b> . . . . .              | <b>14-3</b>  |
| <b>14.2</b> | <b>Interpreting Object Descriptions</b> . . . . .    | <b>14-5</b>  |
| <b>14.3</b> | <b>General Objects</b> . . . . .                     | <b>14-6</b>  |
| <b>14.4</b> | <b>PDO Mapping Objects</b> . . . . .                 | <b>14-10</b> |
| <b>14.5</b> | <b>Sync Manager Communications Objects</b> . . . . . | <b>14-18</b> |
| <b>14.6</b> | <b>Manufacturer-Specific Objects</b> . . . . .       | <b>14-22</b> |
| <b>14.7</b> | <b>Device Control</b> . . . . .                      | <b>14-28</b> |



|              |   |              |
|--------------|---|--------------|
| <b>14.8</b>  | <b>Profile Position Mode . . . . .</b>                            | <b>14-36</b> |
| <b>14.9</b>  | <b>Homing Mode . . . . .</b>                                      | <b>14-38</b> |
| <b>14.10</b> | <b>Position Control Function. . . . .</b>                         | <b>14-40</b> |
| <b>14.11</b> | <b>Interpolated Position Mode . . . . .</b>                       | <b>14-42</b> |
| <b>14.12</b> | <b>Cyclic Synchronous Position Mode . . . . .</b>                 | <b>14-48</b> |
| <b>14.13</b> | <b>Profile Velocity/Cyclic Synchronous Velocity Mode. . . . .</b> | <b>14-49</b> |
| <b>14.14</b> | <b>Profile Torque/Cyclic Synchronous Torque Mode . . . . .</b>    | <b>14-50</b> |
| <b>14.15</b> | <b>Torque Limit Function . . . . .</b>                            | <b>14-51</b> |
| <b>14.16</b> | <b>Touch Probe Function . . . . .</b>                             | <b>14-52</b> |
| <b>14.17</b> | <b>Digital Inputs/Outputs . . . . .</b>                           | <b>14-54</b> |

## **15** Maintenance

|             |  |              |
|-------------|--|--------------|
| <b>15.1</b> | <b>Inspections and Part Replacement . . . . .</b>                                  | <b>15-2</b>  |
|             | 15.1.1 Inspections . . . . .   | 15-2         |
|             | 15.1.2 Guidelines for Part Replacement . . . . .                                   | 15-2         |
|             | 15.1.3 Replacing the Battery . . . . .   | 15-3         |
| <b>15.2</b> | <b>Alarm Displays . . . . .</b>  | <b>15-5</b>  |
|             | 15.2.1 List of Alarms . . . . .  | 15-5         |
|             | 15.2.2 Troubleshooting Alarms . . . . .  | 15-11        |
|             | 15.2.3 Resetting Alarms . . . . .  | 15-41        |
|             | 15.2.4 Displaying the Alarm History . . . . .                                      | 15-42        |
|             | 15.2.5 Clearing the Alarm History . . . . .  | 15-43        |
|             | 15.2.6 Resetting Motor Type Alarms. . . . .  | 15-44        |
| <b>15.3</b> | <b>Warning Displays . . . . .</b>  | <b>15-46</b> |
|             | 15.3.1 List of Warnings. . . . .   | 15-46        |
|             | 15.3.2 Troubleshooting Warnings . . . . .  | 15-47        |
| <b>15.4</b> | <b>Troubleshooting Based on the Operation and Conditions of the Servomotor . .</b> | <b>15-53</b> |

## **16** Parameter and Object Lists

|             |   |              |
|-------------|---|--------------|
| <b>16.1</b> | <b>List of Servo Parameters . . . . .</b>         | <b>16-2</b>  |
|             | 16.1.1 Interpreting the Parameter Lists . . . . . | 16-2         |
|             | 16.1.2 List of Parameters . . . . .               | 16-3         |
| <b>16.2</b> | <b>Object List . . . . .</b>                      | <b>16-39</b> |
| <b>16.3</b> | <b>SDO Abort Code List . . . . .</b>              | <b>16-53</b> |

---

|             |  |              |
|-------------|--|--------------|
| <b>16.4</b> | <b>Parameter Recording Table . . . . .</b> | <b>16-54</b> |
|-------------|--|--------------|

# 17

## Appendices

---

|             |  |             |
|-------------|--|-------------|
| <b>17.1</b> | <b>Interpreting Panel Displays . . . . .</b> | <b>17-2</b> |
|-------------|--|-------------|

|        |  |      |
|--------|--|------|
| 17.1.1 | Interpreting Status Displays . . . . . | 17-2 |
| 17.1.2 | Alarm and Warning Displays . . . . .   | 17-2 |
| 17.1.3 | Overtravel Display . . . . .           | 17-2 |
| 17.1.4 | Forced Stop Display . . . . .          | 17-2 |

|             |   |             |
|-------------|---|-------------|
| <b>17.2</b> | <b>Corresponding SERVOPACK and SigmaWin+ Function Names . .</b> | <b>17-3</b> |
|-------------|---|-------------|

|        |  |      |
|--------|--|------|
| 17.2.1 | Corresponding SERVOPACK Utility Function Names . . . . .         | 17-3 |
| 17.2.2 | Corresponding SERVOPACK Monitor Display Function Names . . . . . | 17-5 |

## Index

## Revision History

# Basic Information on SERVOPACKs

# 1

This chapter provides information required to select SERVOPACKs, such as SERVOPACK models and combinations with Servomotors.

|            |   |             |
|------------|---|-------------|
| <b>1.1</b> | <b>The <math>\Sigma</math>-7 Series</b>                     | <b>1-3</b>  |
| <b>1.2</b> | <b>Introduction to EtherCAT</b>                             | <b>1-4</b>  |
| 1.2.1      | Introduction to CANopen                                     | 1-4         |
| 1.2.2      | CANopen over EtherCAT OSI Model                             | 1-4         |
| 1.2.3      | Sending and Receiving Data in EtherCAT (CoE) Communications | 1-5         |
| 1.2.4      | CoE Terminology   | 1-5         |
| 1.2.5      | Data Types  | 1-6         |
| 1.2.6      | Data Ranges   | 1-6         |
| 1.2.7      | Object Numbers for Each Axis                                | 1-7         |
| <b>1.3</b> | <b>Interpreting the Nameplate</b>                           | <b>1-8</b>  |
| <b>1.4</b> | <b>Part Names</b>   | <b>1-9</b>  |
| <b>1.5</b> | <b>Model Designations</b>                                   | <b>1-11</b> |
| 1.5.1      | Interpreting SERVOPACK Model Numbers                        | 1-11        |
| 1.5.2      | Interpreting Servomotor Model Numbers                       | 1-12        |
| <b>1.6</b> | <b>Combinations of SERVOPACKs and Servomotors</b>           | <b>1-13</b> |
| 1.6.1      | Combinations of Rotary Servomotors and SERVOPACKs           | 1-13        |
| 1.6.2      | Combinations of Linear Servomotors and SERVOPACKs           | 1-13        |
| <b>1.7</b> | <b>Functions</b>  | <b>1-14</b> |

**1.8 EtherCAT Communications LED Indicators . . 1-17**

- 1.8.1 RUN .....1-17
- 1.8.2 ERR .....1-18
- 1.8.3 Link/Activity .....1-18

## 1.1 The $\Sigma$ -7 Series

The  $\Sigma$ -7-series SERVOPACKs are designed for applications that require frequent high-speed and high-precision positioning. The SERVOPACK will make the most of machine performance in the shortest time possible, thus contributing to improving productivity.

The  $\Sigma$ -7-series SERVOPACKs include  $\Sigma$ -7S SERVOPACKs for single-axis control and  $\Sigma$ -7W SERVOPACKs for two-axis control.

**Information** In this manual, the axes are called axis A and axis B. However, they are displayed as “axis 1,” “axis 2,” “AXIS#00,” or “AXIS#01” on the Engineering Tool.

# 1.2 Introduction to EtherCAT

The CANopen over EtherCAT (CoE) Communications Reference SERVOPACKs implement the CiA 402 CANopen drive profile for EtherCAT communications (real-time Ethernet communications).

Basic position, speed, and torque control are supported along with synchronous position, speed, and torque control. You can select the type of control to match your system from basic positioning to high-speed, high-precision path control.

You can also use EtherCAT communications to control the high-level servo control performance, advanced turning functions, and many actuators of the  $\Sigma$ -7 Series.

## 1.2.1 Introduction to CANopen

The CiA 402 CANopen profile is based on the IEC 61800-7-1, IEC61800-7-201, and IEC 61800-7-301 standards for international standardization of drive control and operation control.

## 1.2.2 CANopen over EtherCAT OSI Model

The OSI model implemented by the SERVOPACKs consists of three layers: the application layer (CANopen), the data link layer (EtherCAT), and the physical layer (Ethernet). The four layers other than the application layer, data link layer, and physical layer are not used. The data link layer is implemented with EtherCAT communications and the application layer is implemented with the DS402 CANopen drive profile.

This manual describes mainly the specifications of the application layer implemented in the SERVOPACKs. For detailed information on the data link layer (EtherCAT), refer to documentation provided by the EtherCAT Technology Group.

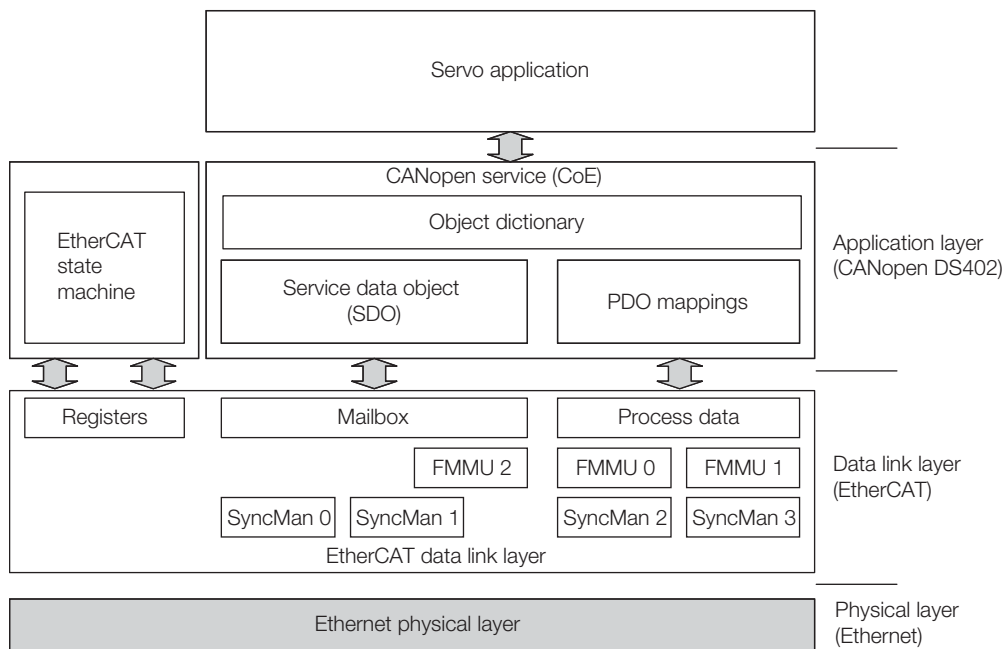

The object dictionary in the application layer includes parameters, application data, and PDO mapping information between the master and slaves.

The process data objects (PDOs) consist of the objects in the object dictionary that can be mapped to PDO mappings. The PDO mappings define the structure and contents of the process data.

## 1.2.3 Sending and Receiving Data in EtherCAT (CoE) Communications

Objects are used to send and receive data in EtherCAT (CoE) communications.

Reading and writing object data is performed in process data communications (PDO service), which transfers data cyclically, and in mailbox communications (SDO service), which transfers data non-cyclically.

Process data communications are used to read and write PDOs. Mailbox communications (SDO) are used to read and write object dictionary data entries.

## 1.2.4 CoE Terminology

The EtherCAT and CANopen terms that are used in this manual are described in the following table.

| Term  | Abbreviation | Description   |
|---|--------------|---|
| CAN in Automation                                   | CiA          | A non-profit organization established in 1992 as a joint venture between companies to provide CAN technical information, product information, and marketing information.                              |
| Controller Area Network                             | CAN          | Communications protocol for the physical layer and data link layer established for automotive LANs. It was established as an international standard as ISO 11898.                                     |
| CANopen   | CANopen      | An upper-layer protocol based on the international CAN standard (EN 50325-4). It consists of profile specifications for the application layer, communications, applications, devices, and interfaces. |
| CANopen over EtherCAT                               | CoE          | A network that uses Ethernet for the physical layer, EtherCAT for the data link layer, and CANopen for the application layer in a seven-layer OSI reference model.                                    |
| Distributed Clocks                                  | DC           | A clock distribution mechanism that is used to synchronize the EtherCAT slaves with the EtherCAT master.  |
| Electrically Erasable Programmable Read Only Memory | EEPROM       | A ROM that can be electrically overwritten.   |
| EtherCAT Slave Controller                           | ESC          | A hardware chip that processes EtherCAT communications (such as loopbacks) and manages the distributed clock.   |
| EtherCAT State Machine                              | ESM          | A state machine in which the state of EtherCAT (the data link layer) changes according to transition conditions.  |
| EtherCAT Technology Group                           | ETG          | An international organization established in 2003 to provide support for developing EtherCAT technologies and to promote the spread of EtherCAT technologies.   |
| Ethernet for Control Automation Technology          | EtherCAT     | An open network developed by Beckhoff Automation.   |
| Fieldbus Memory Management Unit                     | FMMU         | A unit that manages fieldbus memory.  |
| INIT  | INIT         | The Init state in the EtherCAT state machine.   |
| OPERATIONAL   | OP           | The Operational state in the EtherCAT state machine.  |
| Object Dictionary                                   | OD           | A group of objects and structure supported by an EtherCAT SERVOPACK.  |
| Process Data Object                                 | PDO          | Objects that are sent and received in cyclic communications.  |
| Process Data Object Mapping                         | PDO mapping  | Definitions of the applications objects that are sent with PDOs.  |
| Service Data Object                                 | SDO          | Objects that are sent and received in mailbox communications.   |
| PRE-OPERATIONAL                                     | PREOP        | The Pre-operational state in the EtherCAT state machine.  |
| Process data  | –            | The data contained in application objects that are periodically transferred for measurements or controls.   |

Continued on next page.

Continued from previous page.

| Term                         | Abbreviation | Description  |
|------------------------------|--------------|--|
| SyncManager                  | –            | The ESC unit that coordinates data exchange between the master and slaves. |
| Receive Process Data Object  | RXPDO        | The process data received by the ESC.                                      |
| Transmit Process Data Object | TXPDO        | The process data sent by the ESC.  |

## 1.2.5 Data Types

The following table lists the data types and ranges that are used in this manual.

| Code   | Data Type               | Range                           |
|--------|-------------------------|---------------------------------|
| SINT   | Signed 8-bit integer    | -128 to 127                     |
| INT    | Signed 16-bit integer   | -32,768 to 32,767               |
| DINT   | Signed 32-bit integer   | -2,147,483,648 to 2,147,483,627 |
| USINT  | Unsigned 8-bit integer  | 0 to 255                        |
| UINT   | Unsigned 16-bit integer | 0 to 65,535                     |
| UDINT  | Unsigned 32-bit integer | 0 to 4,294,967,295              |
| STRING | Character string        | –                               |

## 1.2.6 Data Ranges

The following table lists the data units and notations that are used in this manual.

| Notation  | Description   |
|-----------|---|
| Pos. unit | The user-defined position reference unit that is set in <i>position user unit</i> (2701h).<br>1 [Pos. unit] = 2701: 01h/2701: 02h [inc]                                       |
| Vel. unit | The user-defined speed reference unit that is set in <i>velocity user unit</i> (2702h).<br>1 [Vel. unit] = 2702: 01h/2702: 02h [inc/s]  |
| Acc. unit | The user-defined acceleration reference unit that is set in <i>acceleration user unit</i> (2703h).<br>1 [Acc. unit] = 2703: 01h/2703: 02h $\times 10^4$ [inc/s <sup>2</sup> ] |
| Trq. unit | The user-defined torque reference unit that is set in <i>torque user unit</i> (2704h).<br>1 [Trq. unit] = 2704: 01h/2704: 02h [0.1%]  |
| inc       | This is the encoder pulse unit.<br>For a 24-bit encoder, the resolution is $16,777,216 \times Pn210/Pn20E$ [inc] per rotation.  |



## 1.2.7 Object Numbers for Each Axis

The follow object numbers are set for SERVOPACKs with two axes (axis A and axis B).

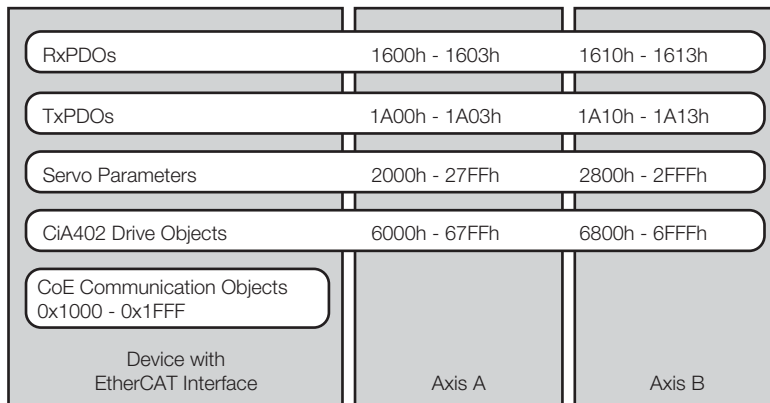

The manual is written to give the settings for axis A. Refer to the following table to make settings for axis B.

| Axis   | RxPDOs        | TxPDOs        | Servo Parameters | CiA402 Drive Objects |
|--------|---------------|---------------|------------------|----------------------|
| Axis A | 1600h - 1603h | 1A00h - 1A03h | 0x2000 - 0x27FF  | 0x6000 - 0x67FF      |
| Axis B | 1610h - 1613h | 1A10h - 1A13h | 0x2800 - 0x2FFF  | 0x6800 - 0x6FFF      |

# 1.3 Interpreting the Nameplate

The following basic information is provided on the nameplate.

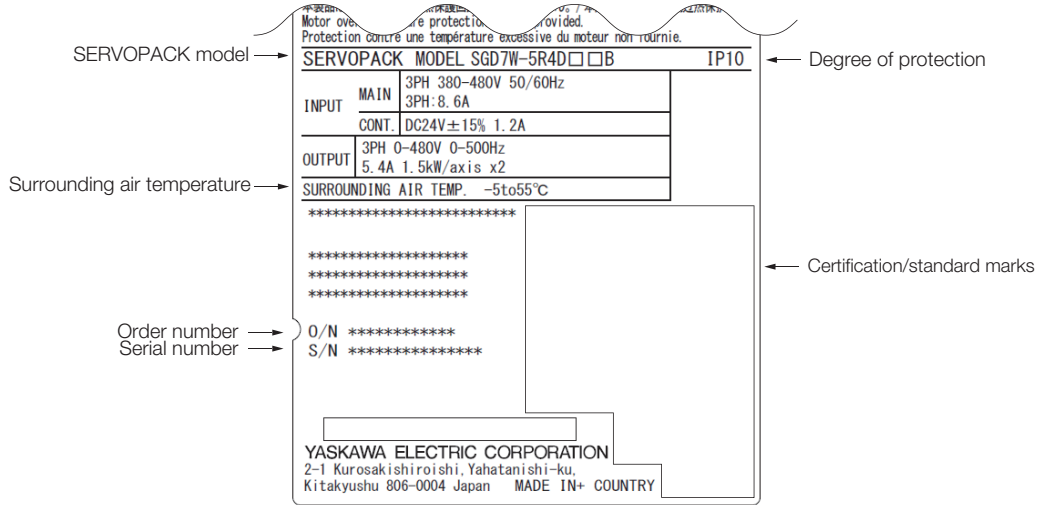

# 1.4 Part Names

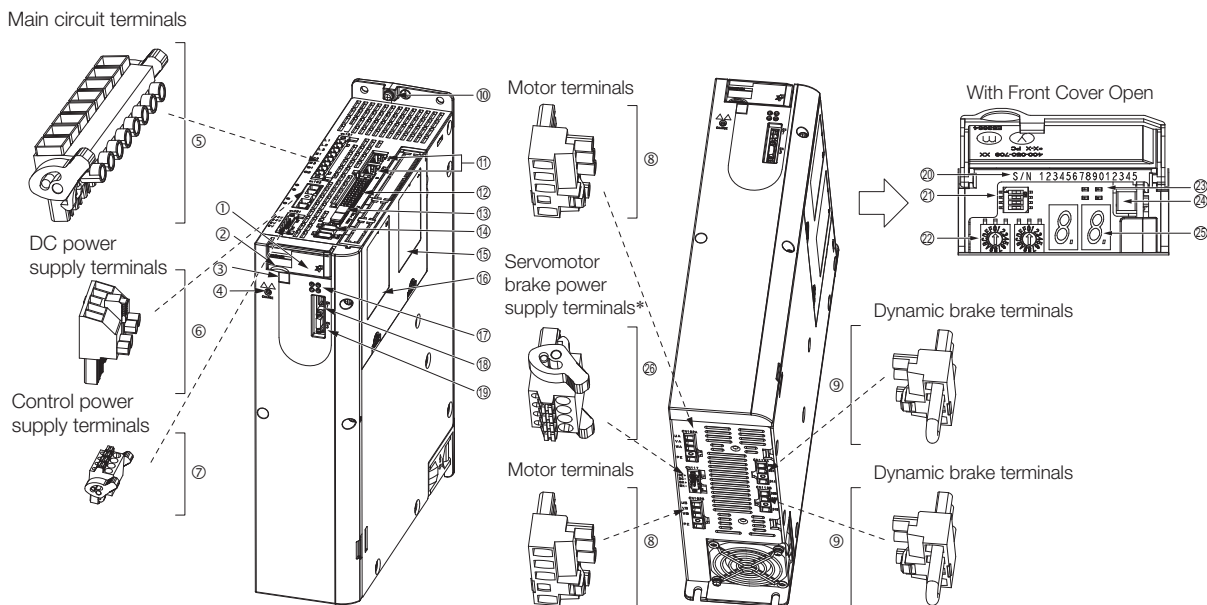

| No. | Name   | Description   | Reference |
|-----|--|---|-----------|
| ①   | Front Cover  | —   | —         |
| ②   | Model  | The model of the SERVOPACK.   | page 1-11 |
| ③   | QR Code  | The QR code that is used by the MechatroCloud service.  | —         |
| ④   | CHARGE   | Lit while the main circuit power is being supplied.<br>Note: Even if you turn OFF the main circuit power supply, this indicator will be lit as long as the internal capacitor remains charged. Do not touch the main circuit or motor terminals while this indicator is lit. Doing so may result in electric shock. | —         |
| ⑤   | Main Circuit Terminals   | The terminals depend on the main circuit power supply input specifications of the SERVOPACK.  | page 4-11 |
| ⑥   | DC Power Supply Terminals  | —   | page 4-11 |
| ⑦   | Control Power Supply Terminals   | The connection terminals for the control power supply.  | page 4-11 |
| ⑧   | Servomotor Terminals (U, V, and W) and Ground Terminal (PE)                | The connection terminals for the Servomotor Main Circuit Cable (power line).  | page 4-19 |
| ⑨   | Dynamic Brake Terminals  | The connection terminals for a Dynamic Brake Resistor.  | page 5-7  |
| ⑩   | Ground Terminal (⊕)  | The ground terminals to prevent electric shock. Always connect this terminal.   | —         |
| ⑪   | EtherCAT Communications Connectors (ETHERCAT IN: CN6A, ETHERCAT OUT: CN6B) | Connect to EtherCAT devices.  | page 4-46 |
| ⑫   | I/O Signal Connector (CN1)   | Connects to sequence I/O signals.   | page 4-36 |
| ⑬   | Safety Connector (CN8A/CN8B)   | Connects to a safety function device.   | page 4-43 |
| ⑭   | Encoder Connector (CN2A/CN2B)  | <ul style="list-style-type: none"> <li>Rotary Servomotor: Connects to the encoder in the Servomotor.</li> <li>Linear Servomotor: Connects to a Serial Converter Unit or linear encoder.</li> </ul>  | page 4-43 |
| ⑮   | Safety Option Module Connector   | Connects to a Safety Option Module.   | —         |
| ⑯   | Feedback Option Module Connector   | Connects to a Feedback Option Module.   | —         |

Continued on next page.

Continued from previous page.

| No. | Name   | Description  | Reference |
|-----|--|--|-----------|
| ⑰   | Communications Status Indicators                 | Indicate the status of EtherCAT communications.  | page 1-17 |
| ⑱   | Computer Connector (CN7)                         | A USB connector to connect a computer.   | page 4-19 |
| ⑲   | Serial Communications Connector (CN3)            | Connects to the Digital Operator.  | page 4-48 |
| ⑳   | Serial Number                                    | –  | –         |
| ㉑   | DIP Switch (S3)                                  | Not used.  | –         |
| ㉒   | EtherCAT Secondary Address (S1 and S2)           | Use these switches to set the device ID and address.   | page 12-5 |
| ㉓   | PWR  | Lights when the control power is being supplied.   | –         |
| ㉔   | Analog Monitor Connector (CN5)                   | You can use a special cable (peripheral device) to monitor the motor speed, torque reference, or other values. | page 4-48 |
| ㉕   | Panel Display                                    | Displays the servo status with a seven-segment display.  | page 17-2 |
| ㉖   | Servomotor Brake Power Supply Terminals (CN117)* | Connect to the power supply for the Servomotor brake.  | –         |

\* SERVOPACKs without built-in Servomotor brake control do not have these terminals.

# 1.5 Model Designations

## 1.5.1 Interpreting SERVOPACK Model Numbers

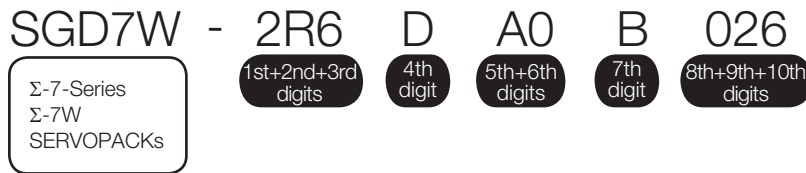

**1st+2nd+3rd digits** Maximum Applicable Motor Capacity per Axis

| Voltage              | Code | Specification |
|----------------------|------|---------------|
| Three-Phase, 400 VAC | 2R6  | 0.75 kW       |
|                      | 5R4  | 1.5 kW        |

**4th digit** Voltage

| Code | Specification |
|------|---------------|
| D    | 400 VAC       |

**5th+6th digits** Interface\*

| Code | Specification                      |
|------|------------------------------------|
| A0   | EtherCAT communications references |

**7th digit** Design Revision Order  
B

**8th+9th+10th digits** Hardware Options Specification

| Code | Specification                     | Applicable Models |
|------|-----------------------------------|-------------------|
| None | Without options                   | All models        |
| 026  | Built-in Servomotor brake control | All models        |

\* The same SERVOPACKs are used for both Rotary Servomotors and Linear Servomotors.

## 1.5.2 Interpreting Servomotor Model Numbers

This section outlines the model numbers of  $\Sigma$ -7-series Servomotors. Refer to the relevant manual in the following list for details.

📖  $\Sigma$ -7-Series Rotary Servomotor with 400 V-Input Power Product Manual (Manual No.: SIEP S800001 86)

📖  $\Sigma$ -7-Series Linear Servomotor with 400 V-Input Power Product Manual (Manual No.: SIEP S800001 81)

### Rotary Servomotors



| Code  | Specifications                          |
|-------|---|
| SGM7J | Medium inertia, high speed              |
| SGM7A | Low inertia, high speed                 |
| SGM7G | Medium inertia, low speed, high torque  |
|       | Medium inertia, high speed, high torque |

- 1st+2nd digits** Rated Output
  - SGM7J: 200 W to 1.5 kW
  - SGM7A: 200 W to 7.0 kW
  - SGM7G: 450 W to 15 kW
- 3rd digit** Power Supply Voltage
  - 400 VAC
- 4th digit** Serial Encoder Specification
  - 24-bit absolute
  - 24-bit incremental
- 5th digit** Design Revision Order
- 6th digit** Shaft End Specification
  - Straight without key
  - Straight with key and tap
- 7th digit** Options
  - With holding brake
  - With dust seal

### Linear Servomotors



**Series**  $\Sigma$ -7-Series Servomotors

**1st digit** Servomotor Type

| Code | Specification                |
|------|------------------------------|
| F    | Models with F-type iron core |
| T    | Models with T-type iron core |

**2nd digit** Moving Coil/Magnetic Way

| Code | Specification |
|------|---------------|
| W    | Moving Coil   |
| W2   |               |
| M    | Magnetic Way  |
| M2   |               |

**3rd digit on**

The specifications for the 3rd digit on depend on the Servomotor type.

# 1.6 Combinations of SERVOPACKs and Servomotors

## 1.6.1 Combinations of Rotary Servomotors and SERVOPACKs

| Rotary Servomotor Model  |             | Capacity | SERVOPACK Model |
|--|-------------|----------|-----------------|
|  |             |          | SGD7W-          |
| SGM7J<br>(Medium Inertia,<br>High Speed),<br>3,000 min <sup>-1</sup>                                   | SGM7J-02D□F | 200 W    | 2R6D*           |
|  | SGM7J-04D□F | 400 W    | 2R6D* or 5R4D*  |
|  | SGM7J-08D□F | 750 W    | 2R6D or 5R4D*   |
|  | SGM7J-15D□F | 1.5 kW   | 5R4D            |
| SGM7A<br>(Low Inertia,<br>High Speed),<br>3,000 min <sup>-1</sup>                                      | SGM7A-02D□F | 200 W    | 2R6D*           |
|  | SGM7A-04D□F | 400 W    | 2R6D* or 5R4D*  |
|  | SGM7A-08D□F | 750 W    | 2R6D or 5R4D*   |
|  | SGM7A-10D□F | 1.0 kW   | 5R4D*           |
|  | SGM7A-15D□F | 1.5 kW   | 5R4D            |
| SGM7G<br>Standard Models<br>(Medium Inertia,<br>Low Speed,<br>High Torque),<br>1,500 min <sup>-1</sup> | SGM7G-05D□F | 450 W    | 2R6D* or 5R4D*  |
|  | SGM7G-09D□F | 850 W    | 5R4D*           |
|  | SGM7G-13D□F | 1.3 kW   | 5R4D            |
| SGM7G<br>High-speed Models<br>(Medium Inertia, High<br>Speed, High Torque)<br>1,500 min <sup>-1</sup>  | SGM7G-05D□R | 450 W    | 2R6D or 5R4D*   |
|  | SGM7G-09D□R | 850 W    | 5R4D            |

\* If you use this combination, responsiveness to a reference may not be as good, e.g., the control gain may not increase, in comparison with using a Σ-7S SERVOPACK.

## 1.6.2 Combinations of Linear Servomotors and SERVOPACKs

| Linear Servomotor Model                    |                | Rated Force [N] | Instantaneous Maximum Force [N] | SERVOPACK Model |
|--|----------------|-----------------|---------------------------------|-----------------|
|  |                |                 |                                 | SGD7W-          |
| SGLF<br>(Models with F-type<br>Iron Cores) | SGLFW-35D120A  | 80              | 220                             | 2R6D            |
|  | SGLFW-35D230A  | 160             | 440                             |                 |
|  | SGLFW-50D380B  | 560             | 1200                            | 5R4D            |
|  | SGLFW-1ZD200B  |                 |                                 |                 |
|  | SGLFW2-30D070A | 45              | 135                             | 2R6D            |
|  | SGLFW2-30D120A | 90              | 270                             |                 |
|  | SGLFW2-90D200A | 560             | 1680                            | 5R4D            |

# 1.7 Functions

This section lists the functions provided by SERVOPACKs. Refer to the reference pages for details on the functions.

- **Functions Related to the Machine**

| Function   | Reference  |
|--|------------|
| Setting the Main Circuit Power Supply Type           | page 6-11  |
| Automatic Detection of Connected Motor               | page 6-12  |
| Motor Direction Setting                              | page 6-13  |
| Linear Encoder Pitch Setting                         | page 6-14  |
| Writing Linear Servomotor Parameters                 | page 6-15  |
| Selecting the Phase Sequence for a Linear Servomotor | page 6-19  |
| Polarity Sensor Setting                              | page 6-21  |
| Polarity Detection                                   | page 6-22  |
| Overtravel Function and Settings                     | page 6-25  |
| Holding Brake  | page 6-31  |
| Motor Stopping Methods for Servo OFF and Alarms      | page 6-36  |
| Resetting the Absolute Encoder                       | page 6-48  |
| Setting the Origin of the Absolute Encoder           | page 6-51  |
| Setting the Regenerative Resistor Capacity           | page 6-54  |
| Operation for Momentary Power Interruptions          | page 7-18  |
| SEMI F47 Function                                    | page 7-19  |
| Setting the Motor Maximum Speed                      | page 7-21  |
| Software Limits and Settings                         | page 7-22  |
| Multiturn Limit Setting                              | page 7-29  |
| Adjustment of Motor Current Detection Signal Offset  | page 7-41  |
| Forcing the Motor to Stop                            | page 7-45  |
| Overheat Protection                                  | page 7-48  |
| Speed Ripple Compensation                            | page 9-59  |
| Current Gain Level Setting                           | page 9-68  |
| Speed Detection Method Selection                     | page 9-68  |
| Safety Functions                                     | page 11-1  |
| Touch Probe  | page 13-23 |



- Functions Related to the Host Controller

| Function  | Reference  |
|---|------------|
| Electronic Gear Settings                            | page 6-41  |
| I/O Signal Allocations                              | page 7-3   |
| ALM (Servo Alarm) Signal                            | page 7-10  |
| /WARN (Warning) Signal                              | page 7-10  |
| /TGON (Rotation Detection) Signal                   | page 7-11  |
| /S-RDY (Servo Ready) Signal                         | page 7-12  |
| /V-CMP (Speed Coincidence Detection) Signal         | page 7-12  |
| /COIN (Positioning Completion) Signal               | page 7-14  |
| /NEAR (Near) Signal                                 | page 7-15  |
| Speed Limit during Torque Control                   | page 7-16  |
| /VLT (Speed Limit Detection) Signal                 | page 7-16  |
| Selecting Torque Limits                             | page 7-23  |
| Vibration Detection Level Initialization            | page 7-37  |
| Alarm Reset   | page 15-41 |
| Replacing the Battery                               | page 15-3  |
| Setting the Position Deviation Overflow Alarm Level | page 9-8   |

- Functions to Achieve Optimum Motions

| Function                            | Reference |
|-------------------------------------|-----------|
| Tuning-less Function                | page 9-12 |
| Autotuning without a Host Reference | page 9-24 |
| Autotuning with a Host Reference    | page 9-35 |
| Custom Tuning                       | page 9-42 |
| Anti-Resonance Control Adjustment   | page 9-50 |
| Vibration Suppression               | page 9-55 |
| Gain Selection                      | page 9-65 |
| Friction Compensation               | page 9-68 |
| Backlash Compensation               | page 9-72 |
| Model Following Control             | page 9-84 |
| Compatible Adjustment Functions     | page 9-87 |
| Mechanical Analysis                 | page 9-91 |
| Easy FFT                            | page 9-93 |

- Functions for Trial Operation during Setup

| Function   | Reference |
|--|-----------|
| Software Reset   | page 7-35 |
| Trial Operation for the Servomotor without a Load        | page 8-7  |
| Program Jogging  | page 8-13 |
| Origin Search  | page 8-19 |
| Test without a Motor                                     | page 8-21 |
| Monitoring Machine Operation Status and Signal Waveforms | page 10-7 |

- Functions for Inspection and Maintenance

| Function                                 | Reference  |
|--|------------|
| Write Prohibition Setting for Parameters | page 6-6   |
| Initializing Parameter Settings          | page 6-9   |
| Automatic Detection of Connected Motor   | page 6-12  |
| Monitoring Product Information           | page 10-2  |
| Monitoring Product Life                  | page 10-2  |
| Alarm History Display                    | page 15-42 |
| Alarm Tracing                            | page 10-17 |

# 1.8 EtherCAT Communications LED Indicators

This diagram shows details of the EtherCAT communications LED indicators.

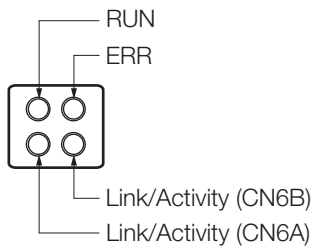

## 1.8.1 RUN

The RUN indicator shows the status of EtherCAT communications.

| LED Indicator |                 | Description  |
|---------------|-----------------|--|
| Status        | Pattern         |  |
| Off           | Constantly off. | EtherCAT communications are in INIT state.                               |
| Blinking      |                 | EtherCAT communications are in PRE-OPERATIONAL state.                    |
| Single flash  |                 | EtherCAT communications are in SAFE-OPERATIONAL state.                   |
| On            | Constantly on.  | EtherCAT communications are in OPERATIONAL state.                        |
| Flickering    |                 | EtherCAT communications have been started but are not yet in INIT state. |

## 1.8.2 ERR

The ERR indicator shows the error status of EtherCAT communications.

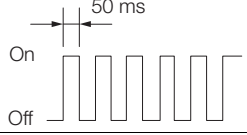
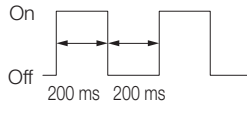
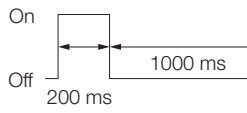
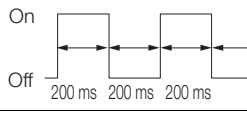
| LED Indicator |  | Description   |
|---------------|--|---|
| Status        | Pattern  |   |
| Off           | Constantly off.  | The EtherCAT communications are in working condition.   |
| Flickering    |   | Booting Error was detected.   |
| Blinking      |   | State change commanded by master is impossible due to register or object settings.              |
| Single flash  |   | Synchronization Error, the EtherCAT Network Module enters SAFE-OPERATIONAL state automatically. |
| Double flash  |  | An application (Sync Manager) watchdog timeout has occurred.                                    |
| On            | Constantly on.   | A PDI Watchdog timeout has occurred.  |

## 1.8.3 Link/Activity

The Link/Activity indicators show whether Communications Cables are connected to the CN6A and CN6B connectors and whether communications are active.

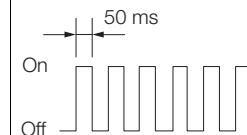
| LED Indicator |   | Description   |
|---------------|---|---|
| Status        | Pattern   |   |
| Off           | Constantly off.   | A Communications Cable is not physically connected.<br>A EtherCAT controller is not started up. |
| Flickering    |  | Data are being exchanged.   |
| On            | Constantly on.  | A Communications Cable is physically connected, but no data being exchanged.                    |

# Selecting a SERVOPACK

# 2

This chapter provides information required to select SERVOPACKs, such as specifications, block diagrams, dimensional drawings, and connection examples.

|            |   |             |
|------------|---|-------------|
| <b>2.1</b> | <b>Ratings and Specifications . . . . .</b>   | <b>2-2</b>  |
| 2.1.1      | Ratings . . . . .   | 2-2         |
| 2.1.2      | SERVOPACK Overload Protection<br>Characteristics . . . . .                            | 2-3         |
| 2.1.3      | Specifications . . . . .  | 2-4         |
| <b>2.2</b> | <b>Block Diagrams . . . . .</b>   | <b>2-8</b>  |
| 2.2.1      | SERVOPACKs without Built-in Servomotor<br>Brake Control . . . . .                     | 2-8         |
| 2.2.2      | SERVOPACKs with Built-in Servomotor<br>Brake Control . . . . .                        | 2-9         |
| <b>2.3</b> | <b>External Dimensions . . . . .</b>  | <b>2-10</b> |
| 2.3.1      | Front Cover Dimensions and Connector<br>Specifications . . . . .                      | 2-10        |
| 2.3.2      | SERVOPACK External Dimensions . . . . .   | 2-11        |
| <b>2.4</b> | <b>Examples of Standard Connections between SERVOPACKs and Peripheral Devices . .</b> | <b>2-12</b> |

## 2.1 Ratings and Specifications

This section gives the ratings and specifications of SERVOPACKs.

### 2.1.1 Ratings

#### Three-Phase, 400 VAC

| Model SGD7W-   |  | 2R6D   | 5R4D  |
|--|--|--|-------|
| Maximum Applicable Motor Capacity per Axis [kW]      |  | 0.75   | 1.5   |
| Continuous Output Current per Axis [Arms]            |  | 2.6  | 5.4   |
| Instantaneous Maximum Output Current per Axis [Arms] |  | 8.5  | 14    |
| Main Circuit   | Power Supply                                       | Three-phase, 380 VAC to 480 VAC, 50 Hz/60 Hz |       |
|  | Permitted Voltage Fluctuation                      | -15% to +10%                                 |       |
|  | Input Current [Arms]*                              | 4.4  | 8.6   |
| Control  | Power Supply                                       | 24 VDC                                       |       |
|  | Permitted Voltage Fluctuation                      | -15% to +15%                                 |       |
|  | Input Current [Arms]*                              | 1.2  |       |
| Power Supply Capacity [kVA]*                         |  | 3.5  | 6.8   |
| Power Loss*  | Main Circuit Power Loss [W]                        | 65.4   | 108.6 |
|  | Control Circuit Power Loss [W]                     | 21   |       |
|  | Built-in Regenerative Resistor Power Loss [W]      | 28   | 28    |
|  | Total Power Loss [W]                               | 114.4  | 157.6 |
| Regenerative Resistor                                | Built-In Regenerative Resistor                     | Resistance [ $\Omega$ ]                      | 43    |
|  |  | Capacity [W]                                 | 140   |
|  | Minimum Allowable External Resistance [ $\Omega$ ] | 43   | 43    |
| Overvoltage Category                                 |  | III  |       |

\* This is the net value at the rated load.

#### 540 VDC

| Model SGD7W-   |                                | 2R6D               | 5R4D  |
|--|--------------------------------|--------------------|-------|
| Maximum Applicable Motor Capacity per Axis [kW]      |                                | 0.75               | 1.5   |
| Continuous Output Current per Axis [Arms]            |                                | 2.6                | 5.4   |
| Instantaneous Maximum Output Current per Axis [Arms] |                                | 8.5                | 14    |
| Main Circuit   | Power Supply                   | 513 VDC to 648 VDC |       |
|  | Permitted Voltage Fluctuation  | -15% to +10%       |       |
|  | Input Current [Arms]*          | 5                  | 11    |
| Control  | Power Supply                   | 24 VDC             |       |
|  | Permitted Voltage Fluctuation  | -15% to +15%       |       |
|  | Input Current [Arms]*          | 1.2                |       |
| Power Supply Capacity [kVA]*                         |                                | 3.5                | 6.8   |
| Power Loss*  | Main Circuit Power Loss [W]    | 47.4               | 90.6  |
|  | Control Circuit Power Loss [W] | 21                 |       |
|  | Total Power Loss [W]           | 68.4               | 111.6 |
| Overvoltage Category                                 |                                | III                |       |

\* This is the net value at the rated load.

## 2.1.2 SERVOPACK Overload Protection Characteristics

The overload detection level is set for hot start conditions with a SERVOPACK surrounding air temperature of 55°C.

An overload alarm (A.710 or A.720) will occur if overload operation that exceeds the overload protection characteristics shown in the following diagram (i.e., operation on the right side of the applicable line) is performed.

The actual overload detection level will be the detection level of the connected SERVOPACK or Servomotor that has the lower overload protection characteristics.

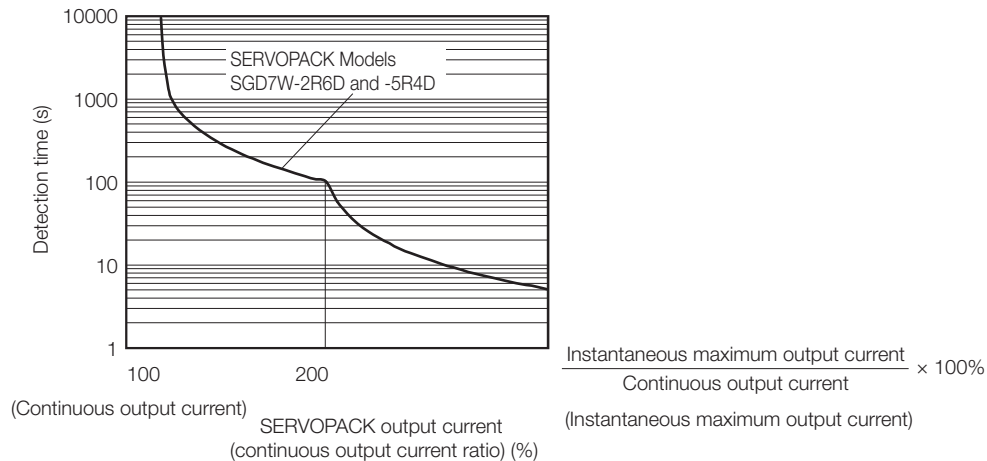

In most cases, that will be the overload protection characteristics of the Servomotor.



Note: The above overload protection characteristics do not mean that you can perform continuous duty operation with an output of 100% or higher.

For a Yaskawa-specified combination of SERVOPACK and Servomotor, maintain the effective torque within the continuous duty zone of the torque-motor speed characteristic of the Servomotor.

## 2.1.3 Specifications

| Item                     |  | Specification  |
|--------------------------|--|--|
| Control Method           |  | IGBT-based PWM control, sine wave current drive  |
| Feedback                 | With Rotary Servomotor                         | Serial encoder: 24 bits<br>(incremental encoder/absolute encoder)  |
|                          | With Linear Servomotor                         | <ul style="list-style-type: none"> <li>Absolute linear encoder (The signal resolution depends on the absolute linear encoder.)</li> <li>Incremental linear encoder (The signal resolution depends on the incremental linear encoder or Serial Converter Unit.)</li> </ul>                |
| Environmental Conditions | Surrounding Air Temperature                    | -5°C to 55°C<br>(With derating, usage is possible between 55°C and 60°C.)<br>Refer to the following section for derating specifications.<br> <b>3.6 Derating Specifications on page 3-7</b>             |
|                          | Storage Temperature                            | -20°C to 85°C  |
|                          | Surrounding Air Humidity                       | 95% relative humidity max. (with no freezing or condensation)  |
|                          | Storage Humidity                               | 95% relative humidity max. (with no freezing or condensation)  |
|                          | Vibration Resistance                           | 4.9 m/s <sup>2</sup>   |
|                          | Shock Resistance                               | 19.6 m/s <sup>2</sup>  |
|                          | Degree of Protection                           | IP10   |
|                          | Pollution Degree                               | 2 <ul style="list-style-type: none"> <li>Must be no corrosive or flammable gases.</li> <li>Must be no exposure to water, oil, or chemicals.</li> <li>Must be no dust, salts, or iron dust.</li> </ul>  |
|                          | Altitude                                       | 1,000 m or less.<br>(With derating, usage is possible between 1,000 m and 2,000 m.)<br>Refer to the following section for derating specifications.<br> <b>3.6 Derating Specifications on page 3-7</b> |
|                          | Others   | Do not use the SERVOPACK in the following locations: Locations subject to static electricity, noise, strong electromagnetic/magnetic fields, or radioactivity  |
| Compliant Standards      |  | Refer to the following section for details.<br> <b>Compliance with UL Standards, EU Directives, UK Regulations, and Other Safety Standards on page xxi</b>  |
| Mounting                 |  | Base-mounted   |
| Performance              | Speed Control Range                            | 1:5000 (At the rated torque, the lower limit of the speed control range must not cause the Servomotor to stop.)  |
|                          | Coefficient of Speed Fluctuation* <sup>1</sup> | ±0.01% of rated speed max. (for a load fluctuation of 0% to 100%)  |
|                          |  | ±0.1% of rated speed max. (for a temperature fluctuation of 25°C ±25°C)  |
|                          | Torque Control Precision (Repeatability)       | ±1%  |
| Soft Start Time Setting  |  | 0 s to 10 s (Can be set separately for acceleration and deceleration.)   |

Continued on next page.



Continued from previous page.

| Item                                 |  | Specification  |  |
|--------------------------------------|--|--|--|
| I/O Signals                          | Linear Servomotor Overheat Protection Signal Input | Number of input points: 1<br>Input voltage range: 0 V to +5 V  |  |
|                                      | Sequence Input Signals                             | Allowable voltage range: 24 VDC $\pm$ 20%<br>Number of input points: 10<br>(Input method: Sink inputs or source inputs)  |  |
|                                      |  | Input Signals That Can Be Allocated  | Input Signals <ul style="list-style-type: none"> <li>• P-OT (Forward Drive Prohibit) and N-OT (Reverse Drive Prohibit) signals</li> <li>• /Probe1 (Probe 1 Latch Input) signal</li> <li>• /Probe2 (Probe 2 Latch Input) signal</li> <li>• /Home (Home Switch Input) signal</li> <li>• /P-CL (Forward External Torque Limit) and /N-CL (Reverse External Torque Limit) signals</li> </ul> A signal can be allocated and the positive and negative logic can be changed. |
|                                      | Sequence Output Signals                            | Fixed Output   | Allowable voltage range: 5 VDC to 30 VDC<br>Number of output points: 1<br>(A photocoupler output (isolated) is used.)<br>Output signal: ALM (Servo Alarm) signal   |
| Output Signals That Can Be Allocated |  | Allowable voltage range: 5 VDC to 30 VDC<br>Number of output points: 6<br>(A photocoupler output (isolated) is used.)<br>Output Signals <ul style="list-style-type: none"> <li>• /COIN (Positioning Completion) signal</li> <li>• /V-CMP (Speed Coincidence Detection) signal</li> <li>• /TGON (Rotation Detection) signal</li> <li>• /S-RDY (Servo Ready) signal</li> <li>• /CLT (Torque Limit Detection) signal</li> <li>• /VLT (Speed Limit Detection) signal</li> <li>• /BK (Brake) signal</li> <li>• /WARN (Warning) signal</li> <li>• /NEAR (Near) signal</li> </ul> A signal can be allocated and the positive and negative logic can be changed. |  |
| Communi-<br>cations                  | RS-422A Communi-<br>cations (CN502)                | Inter-<br>faces  | Digital Operator (JUSP-OP05A-1-E).   |
|                                      |  | 1:N Commu-<br>nications  | Up to N = 15 stations possible for RS-422A port  |
|                                      |  | Axis Address Setting   | Set with parameters.   |
|                                      | USB Com-<br>muni-<br>cations (CN7)                 | Interface  | Personal computer (with SigmaWin+)<br>The software version of the SigmaWin+ must be version 7.11 or higher.  |
| Commu-<br>nica-<br>tions Standard    |  | Conforms to USB2.0 standard (12 Mbps).   |  |

Continued on next page.

## 2.1 Ratings and Specifications

### 2.1.3 Specifications

Continued from previous page.

| Item                                     |                                     | Specification   |
|--|-------------------------------------|---|
| Displays/Indicators                      |                                     | CHARGE, PWR, RUN, ERR, and L/A (A and B) indicators, and two, one-digit seven-segment displays  |
| EtherCAT Communications Setting Switches |                                     | EtherCAT secondary address (S1 and S2), 16 positions  |
| EtherCAT Communications                  | Compliant Communications Standards  | IEC 61158 Type 12, IEC 61800-7 CiA402 Drive Profile   |
|  | Physical Layer                      | 100BASE-TX (IEEE 802.3)   |
|  | Communications Connectors           | CN6A (RJ45): ETHERCAT IN (EtherCAT signal input connector)<br>CN6B (RJ45): ETHERCAT OUT (EtherCAT signal output connector)  |
|  | Cable                               | Category 5, 4 shielded twisted pairs<br>The cable is automatically detected with AUTO MDIX.   |
|  | Sync Manager                        | SM0: Mailbox output, SM1: Mailbox input, SM2: Process data output, and SM3: Process data input  |
|  | FMMU                                | FMMU 0: Mapped in process data output (RxPDO) area.<br>FMMU 1: Mapped in process data input (TxPDO) area.<br>FMMU 2: Mapped to mailbox status.  |
|  | EtherCAT Commands (Data Link Layer) | APRD, FPRD, BRD, LRD, APWR, FPWR, BWR, LWR, ARMW, and FRMW (APRW, FPRW, BRW, and LRW commands are not supported.)   |
|  | Process Data                        | Assignments can be changed with PDO mapping.  |
|  | Mailbox (CoE)                       | Emergency messages, SDO requests, SDO responses, and SDO information (TxPDO/RxPDO and remote TxPDO/RxPDO are not supported.)  |
|  | Distributed Clocks                  | Free-Run Mode and DC Mode (Can be switched.)<br>Applicable DC cycles: 125 $\mu$ s to 4 ms in 125- $\mu$ s increments  |
|  | Slave Information Interface         | 256 bytes (read-only)   |
|  | Indicators                          | EtherCAT communications in progress: Link/Activity x 2<br>EtherCAT communications status: RUN x 1<br>EtherCAT error status: ERR x 1   |
| CiA402 Drive Profile                     |                                     | <ul style="list-style-type: none"> <li>• Homing Mode</li> <li>• Profile Position Mode</li> <li>• Interpolated Position Mode</li> <li>• Profile Velocity Mode</li> <li>• Profile Torque Mode</li> <li>• Cyclic Synchronous Position Mode</li> <li>• Cyclic Synchronous Velocity Mode</li> <li>• Cyclic Synchronous Torque Mode</li> <li>• Touch Probe Function</li> <li>• Torque Limit Function</li> </ul> |
| Analog Monitor (CN5)                     |                                     | Number of points: 2<br>Output voltage range: $\pm 10$ VDC (effective linearity range: $\pm 8$ V)<br>Resolution: 16 bits<br>Accuracy: $\pm 20$ mV (Typ)<br>Maximum output current: $\pm 10$ mA<br>Settling time ( $\pm 1\%$ ): 1.2 ms (Typ)  |
| Dynamic Brake (DB)                       |                                     | Activated when a servo alarm or overtravel (OT) occurs, or when the power supply to the main circuit or servo is OFF.   |
| Regenerative Processing                  |                                     | Built-in<br>Refer to the catalog for details.   |
| Overtravel (OT) Prevention               |                                     | Stopping with dynamic brake, deceleration to a stop, or coasting to a stop for the P-OT (Forward Drive Prohibit) or N-OT (Reverse Drive Prohibit) signal  |
| Protective Functions                     |                                     | Overcurrent, overvoltage, low voltage, overload, regeneration error, etc.   |
| Utility Functions                        |                                     | Gain adjustment, alarm history, jogging, origin search, etc.  |

Continued on next page.

Continued from previous page.

| Item             |                       | Specification  |
|------------------|-----------------------|--|
| Safety Functions | Inputs                | /HWBB_A1, /HWBB_A2, /HWBB_B1, and /HWBB_B2: Base block signals for Power Modules |
|                  | Output                | EDM_A and EDM_B: Monitor the status of built-in safety circuits (fixed outputs). |
|                  | Compliant Standards*2 | ISO13849-1 PLe (category 3), IEC61508 SIL3                                       |

\*1. The coefficient of speed fluctuation for load fluctuation is defined as follows:

$$\text{Coefficient of speed fluctuation} = \frac{\text{No-load motor speed} - \text{Total-load motor speed}}{\text{Rated motor speed}} \times 100\%$$

\*2. Always perform risk assessment for the system and confirm that the safety requirements are met.

# 2.2 Block Diagrams

## 2.2.1 SERVOPACKs without Built-in Servomotor Brake Control

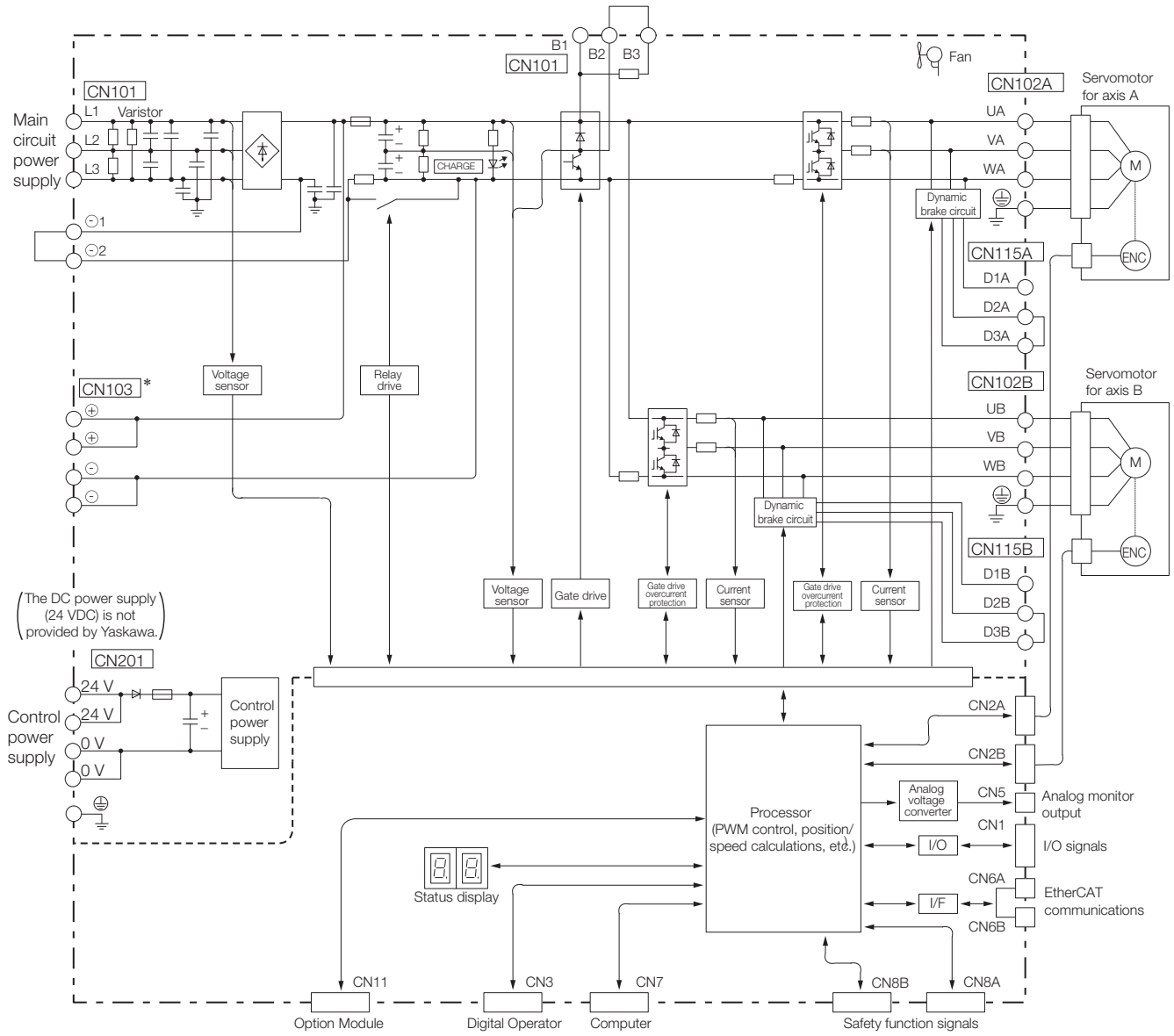

\* If using these terminals, contact your YASKAWA representative.

# 2.2.2 SERVOPACKs with Built-in Servomotor Brake Control

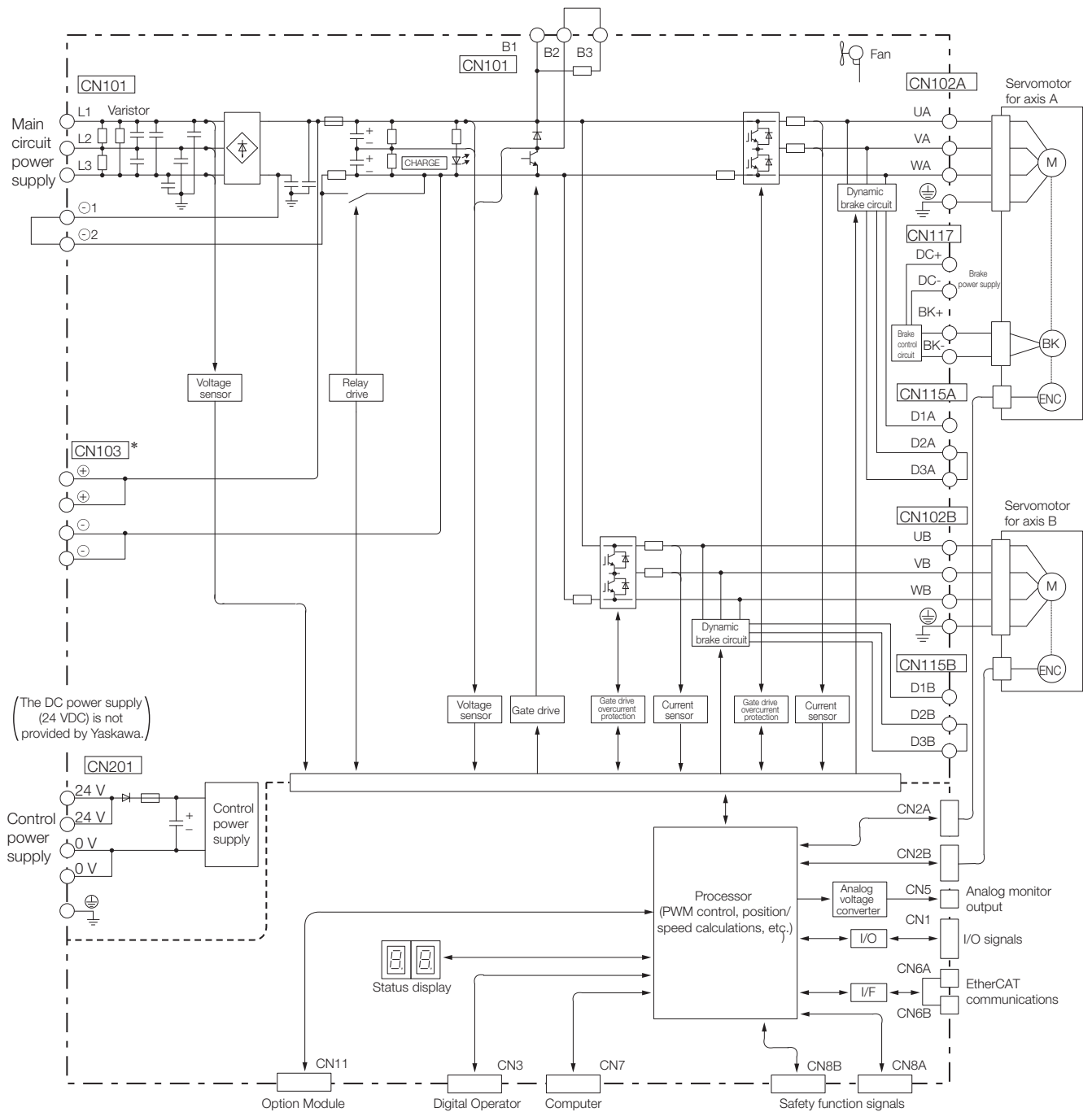

\* If using these terminals, contact your YASKAWA representative.

## 2.3 External Dimensions

### 2.3.1 Front Cover Dimensions and Connector Specifications

The front cover dimensions and panel connector section are the same for all models. Refer to the following figures and table.

- Front Cover Dimensions

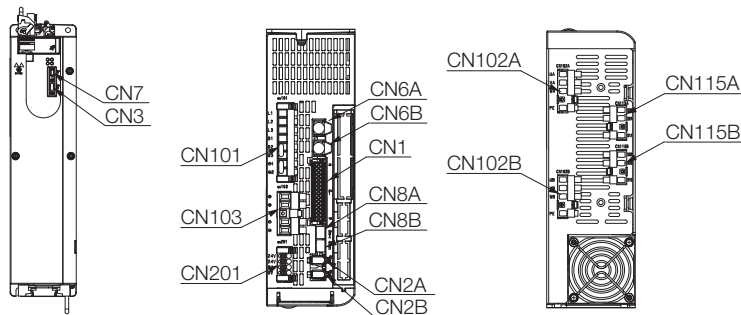
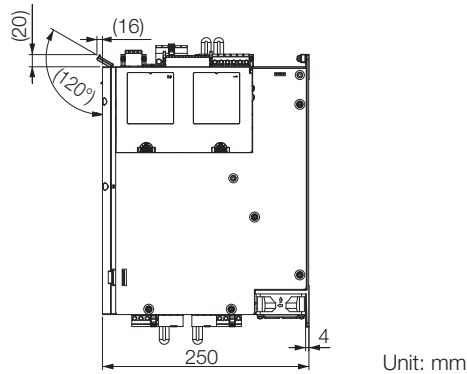

- Connector Specifications

| Connector No.     | Model                             | Number of Pins | Manufacturer                       |
|-------------------|-----------------------------------|----------------|------------------------------------|
| CN1               | DMC 1.5/15-G1F-3.5-LR-BK          | 30             | Phoenix Contact                    |
| CN2A/CN2B         | 3E106-0220KV                      | 6              | 3M Japan Limited                   |
| CN3               | HDR-EC14LFDTN-SLD+                | 14             | Honda Tsushin Kogyo Co., Ltd.      |
| CN6A/CN6B         | 1-1734579-4                       | 8              | Tyco Electronics Japan G.K.        |
| CN7               | 2172034-1                         | 5              | Tyco Electronics Japan G.K.        |
| CN8A/CN8B         | 1903815-1                         | 8              | Tyco Electronics Japan G.K.        |
| CN101             | BLZ 7.62HP/08/180LR SN BK BX PRT  | 8              | Weidmüller Interface GmbH & Co. KG |
| CN102A/<br>CN102B | BLZ 7.62IT/04/180MF4 SN BK BX PRT | 4              | Weidmüller Interface GmbH & Co. KG |
| CN103*            | BVZ 7.62IT/04/180MF3 SN BK BX PRT | 4              | Weidmüller Interface GmbH & Co. KG |
| CN115A/<br>CN115B | BLZ 7.62IT/03/180MF2 SN BK BX PRT | 3              | Weidmüller Interface GmbH & Co. KG |
| CN201             | BLF 5.08HC/04/180LR SN OR BX SO   | 4              | Weidmüller Interface GmbH & Co. KG |

\* If using these terminals, contact your YASKAWA representative.

Note: The above connectors or their equivalents are used for the SERVOPACKs.

## 2.3.2 SERVOPACK External Dimensions

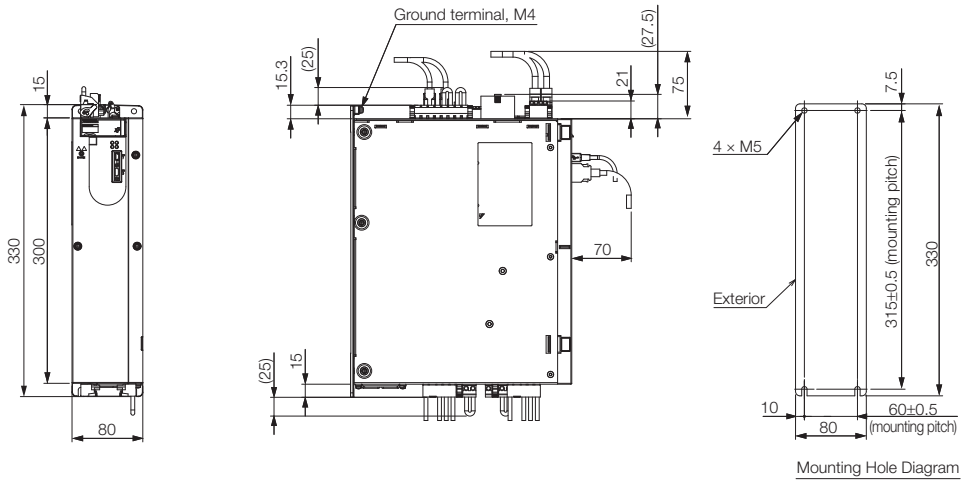

Mounting Hole Diagram

Approx. mass: 2R6D: 4.1 kg  
 5R4D: 4.3 kg  
 Unit: mm

## 2.4 Examples of Standard Connections between SERVOPACKs and Peripheral Devices

### • Rotary Servomotors

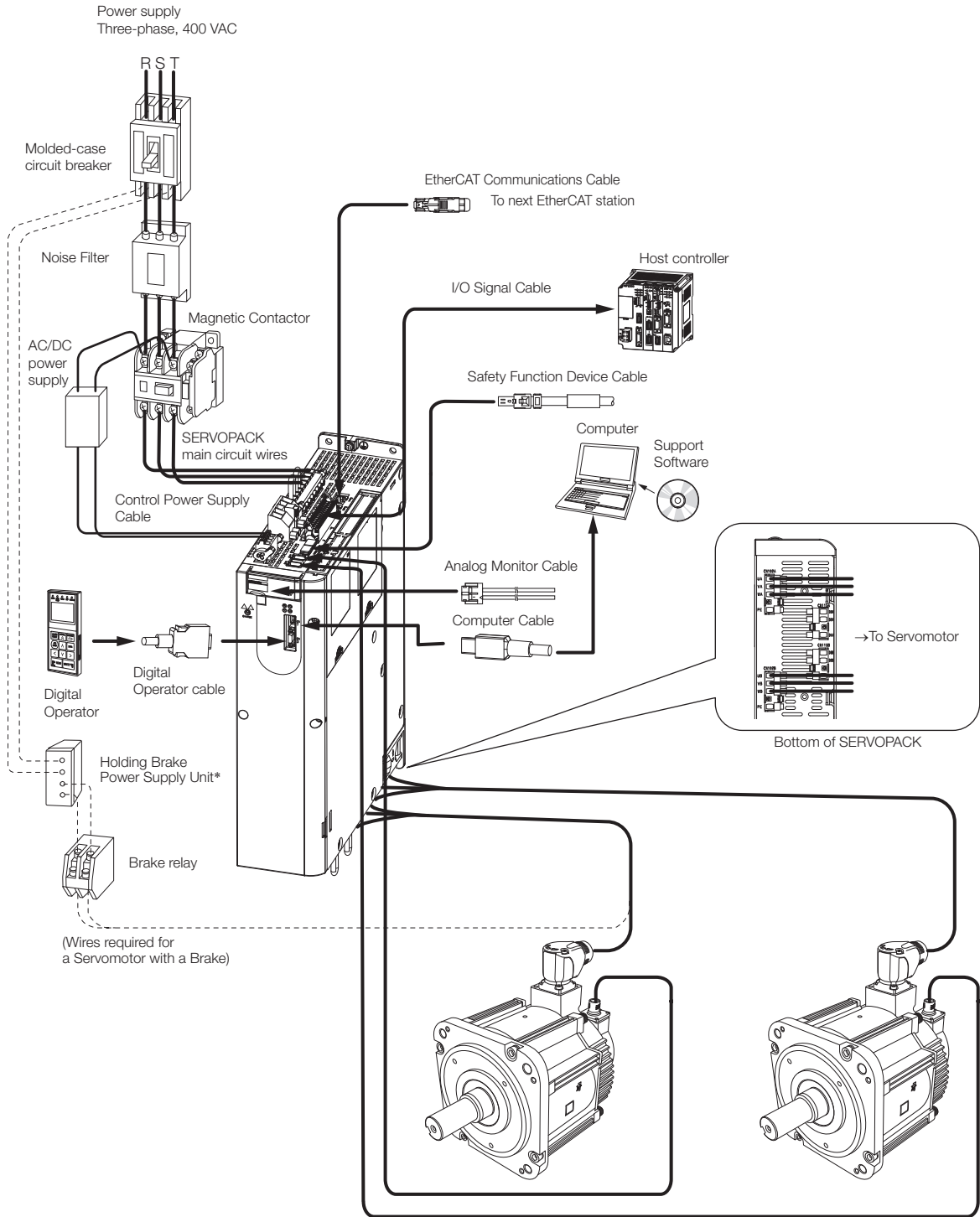

\* The power supply for the holding brake is not provided by Yaskawa. Select a power supply based on the holding brake specifications.  
If you use a 24-V brake, install a separate power supply for the 24-VDC power supply from other power supplies, such as the one for the I/O signals of the CN1 connector.  
If the power supply is shared, the I/O signals may malfunction.



• Linear Servomotors

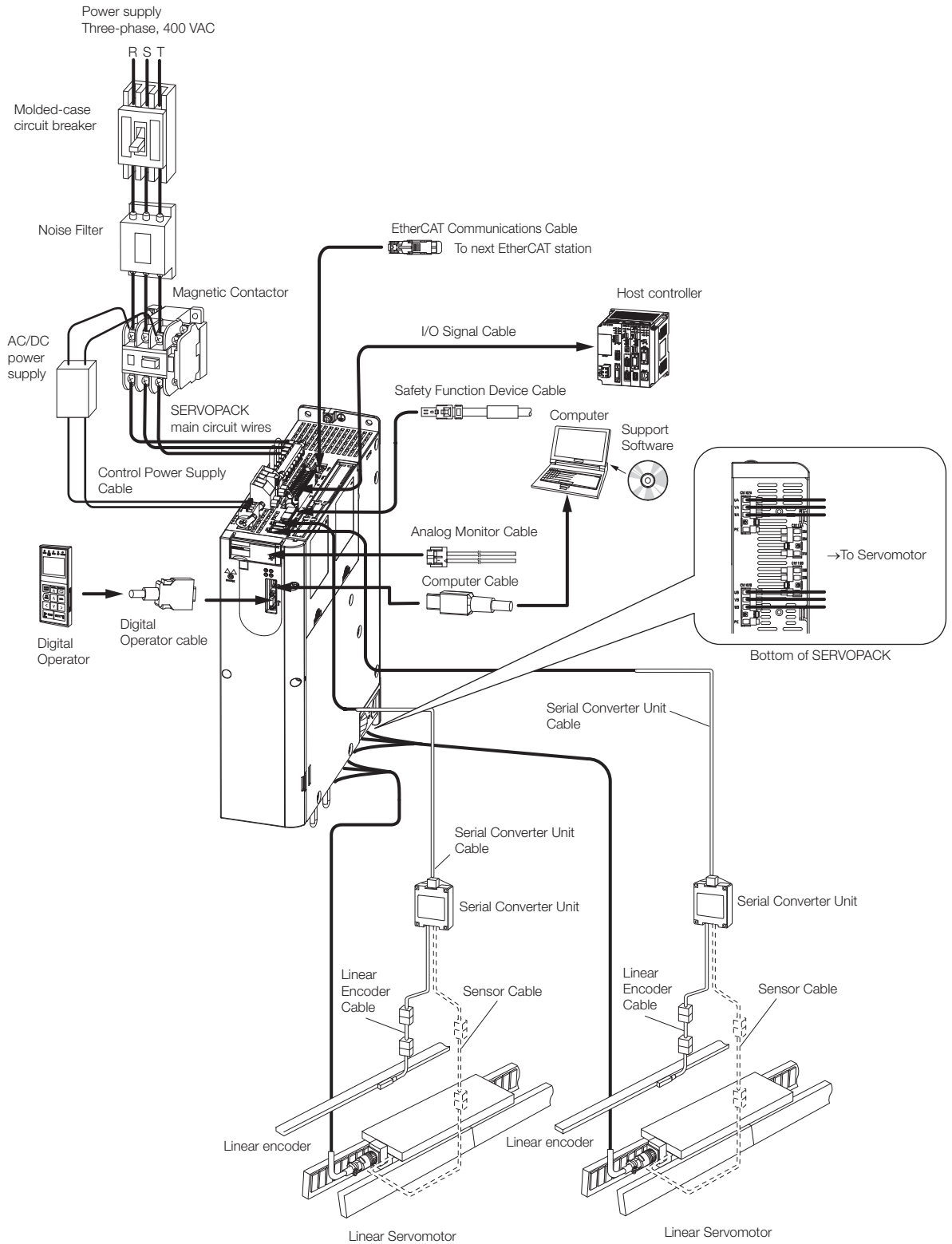



# SERVOPACK Installation

---

# 3

This chapter provides information on installing SERVOPACKs in the required locations.

|            |  |            |
|------------|--|------------|
| <b>3.1</b> | <b>Installation Precautions . . . . .</b>                                | <b>3-2</b> |
| <b>3.2</b> | <b>Mounting Types and Orientation . . . . .</b>                          | <b>3-3</b> |
| <b>3.3</b> | <b>Mounting Hole Dimensions . . . . .</b>                                | <b>3-4</b> |
| <b>3.4</b> | <b>Mounting Interval . . . . .</b>                                       | <b>3-5</b> |
|            | 3.4.1 Installing One SERVOPACK in a Control Panel . .                    | 3-5        |
|            | 3.4.2 Installing More Than One SERVOPACK<br>in a Control Panel . . . . . | 3-5        |
| <b>3.5</b> | <b>Monitoring the Installation Environment . . .</b>                     | <b>3-6</b> |
| <b>3.6</b> | <b>Derating Specifications . . . . .</b>                                 | <b>3-7</b> |
| <b>3.7</b> | <b>EMC Installation Conditions . . . . .</b>                             | <b>3-8</b> |

## 3.1 Installation Precautions

Refer to the following section for the ambient installation conditions.

 2.1.3 Specifications on page 2-4

### ■ Installation Near Sources of Heat

Implement measures to prevent temperature increases caused by radiant or convection heat from heat sources so that the ambient temperature of the SERVOPACK meets the ambient conditions.

### ■ Installation Near Sources of Vibration

Install a vibration absorber on the mounting surface of the SERVOPACK so that the SERVOPACK will not be subjected to vibration.

### ■ Other Precautions

Do not install the SERVOPACK in a location subject to high temperatures, high humidity, water drops, cutting oil, excessive dust, excessive dirt, excessive iron powder, corrosive gasses, or radioactivity.

# 3.2 Mounting Types and Orientation

The SERVOPACKs are based mounted. Mount the SERVOPACK vertically, as shown in the following figure.

Also, mount the SERVOPACK so that the front panel is facing toward the operator.

Note: Prepare three or four mounting holes for the SERVOPACK and mount it securely in the mounting holes. (The number of mounting holes depends on the capacity of the SERVOPACK.)

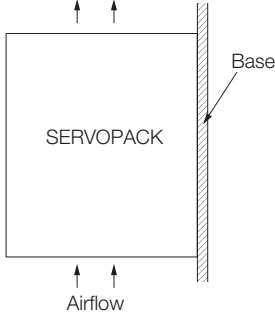

## 3.3 Mounting Hole Dimensions

Use mounting holes to securely mount the SERVOPACK to the mounting surface.

Note: To mount the SERVOPACK, you will need to prepare a screwdriver that is longer than the depth of the SERVOPACK.

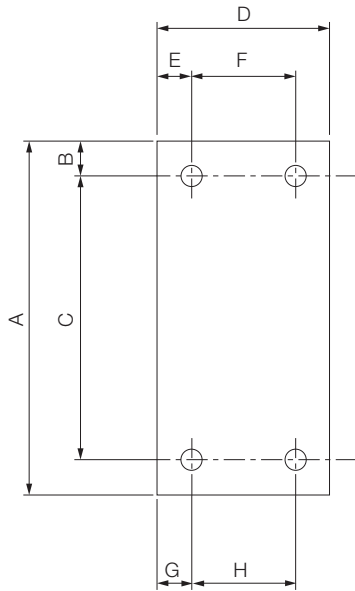

| SERVOPACK Model   | Dimensions (mm) |     |          |    |    |         |    |         | Screw Size | Number of Screws |
|-------------------|-----------------|-----|----------|----|----|---------|----|---------|------------|------------------|
|                   | A               | B   | C        | D  | E  | F       | G  | H       |            |                  |
| SGD7W-2R6D, -5R4D | 330             | 7.5 | 315 ±0.5 | 80 | 10 | 60 ±0.5 | 10 | 60 ±0.5 | M5         | 4                |

## 3.4 Mounting Interval

### 3.4.1 Installing One SERVOPACK in a Control Panel

Provide the following spaces around the SERVOPACK.

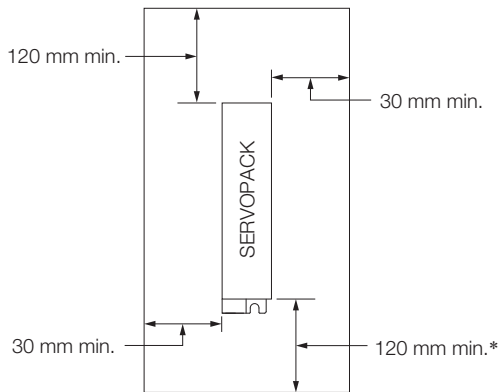

\* For this dimension, ignore items protruding from the main body of the SERVOPACK.

### 3.4.2 Installing More Than One SERVOPACK in a Control Panel

When multiple SERVOPACKs are installed close together in an enclosed space, natural convection may provide insufficient air circulation to distribute heat uniformly through the space, resulting in the air surrounding the SERVOPACKs to locally exceed the surrounding air temperature range. In this case, you must take measures to disperse the localized hot spots, such as by using fans. When using fans, install them as shown below.

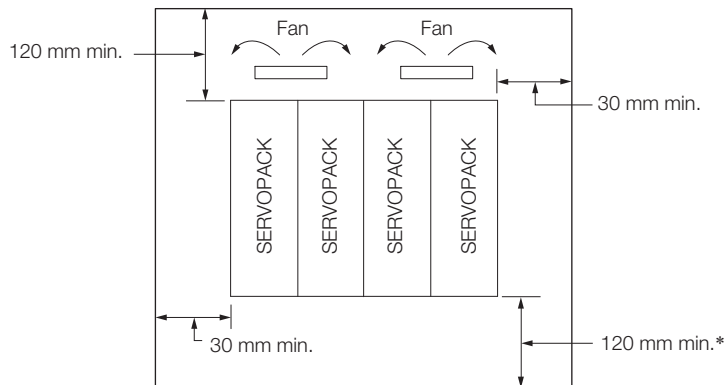

\* For this dimension, ignore items protruding from the main body of the SERVOPACK.

The space required on the right side of a SERVOPACK (when looking at the SERVOPACK from the front) depends on the SERVOPACK models. Refer to the following table.

| SERVOPACK Model | Cooling Fan Installation Conditions |
|-----------------|-------------------------------------|
|                 | SGD7W-2R6D, -5R4D                   |

## 3.5 Monitoring the Installation Environment

You can use the SERVOPACK Installation Environment Monitor parameter to check the operating conditions of the SERVOPACK in the installation environment.

You can check the SERVOPACK installation environment monitor with either of the following methods.

- Using the SigmaWin+: **Life Monitor - Installation Environment Monitor - SERVOPACK**
- Digital Operator: Un025 (Installation Environment Monitor [%])

Implement one or more of the following actions if the monitor value exceeds 100%.

- Lower the surrounding temperature.
- Decrease the load.

**Information** The value of the SERVOPACK Installation Environment Monitor parameter will increase by about 10% for each 10°C increase in the ambient temperature.



Always observe the surrounding air temperature given in the SERVOPACK environment conditions. Even if the monitor value is 100% or lower, you cannot use a SERVOPACK in a location that exceeds the specified surrounding air temperature.



## 3.6 Derating Specifications

If you use the SERVOPACK at a surrounding air temperature of 55°C to 60°C or at an altitude of 1,000 m to 2,000 m, you must apply the derating rates given in the following graphs.

- SGD7W-2R6D, -5R4D

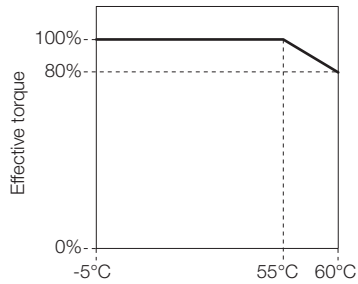

Surrounding air temperature

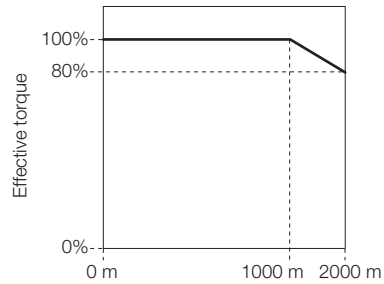

Altitude

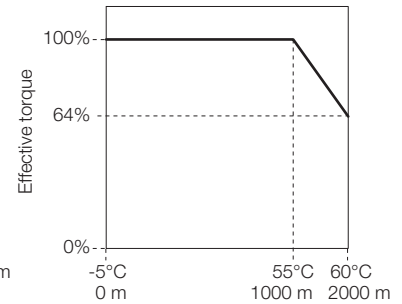

Surrounding air temperature and altitude

## 3.7 EMC Installation Conditions

This section gives the recommended installation conditions that were used for EMC certification testing.

The EMC installation conditions that are given here are the conditions that were used to pass testing criteria at Yaskawa. The EMC level may change under other conditions, such as the actual installation structure and wiring conditions. These Yaskawa products are designed to be built into equipment. Therefore, you must implement EMC measures and confirm compliance for the final equipment.

The compliant standards are EN 55011 Group 1, Class A, EN 61000-6-2, EN 61000-6-4, and EN 61800-3 (Category C2, Second environment).



### WARNING

- In a domestic environment, this product may cause radio interference in which case supplementary mitigation measures may be required.



### CAUTION

- This equipment is not intended for use in residential environments and may not provide adequate protection to radio reception in such environments.

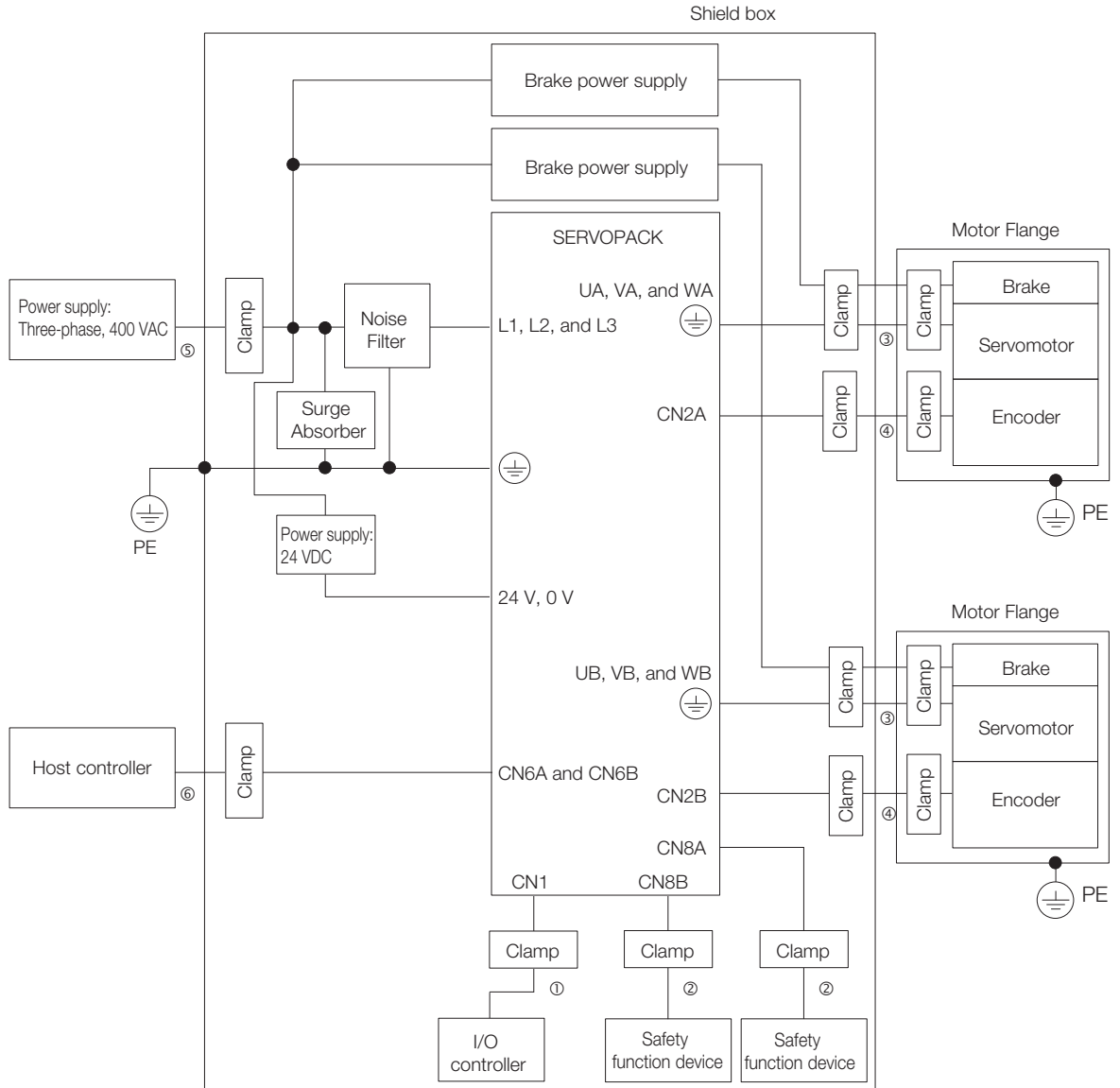

| Symbol | Cable Name                      | Specification  |
|--------|---------------------------------|----------------|
| ①      | I/O Signal Cable                | Shielded cable |
| ②      | Safety Function Device Cable    | Shielded cable |
| ③      | Servomotor Main Circuit Cable   | Shielded cable |
| ④      | Encoder Cable                   | Shielded cable |
| ⑤      | Main Circuit Power Supply Cable | Shielded cable |
| ⑥      | EtherCAT Communications Cable   | Shielded cable |



# Wiring and Connecting SERVOPACKs

# 4

This chapter provides information on wiring and connecting SERVOPACKs to power supplies and peripheral devices.

|            |   |             |
|------------|---|-------------|
| <b>4.1</b> | <b>Wiring and Connecting SERVOPACKs . . . . .</b>               | <b>4-3</b>  |
| 4.1.1      | General Precautions . . . . .                                   | 4-3         |
| 4.1.2      | Countermeasures against Noise . . . . .                         | 4-5         |
| 4.1.3      | Grounding . . . . .   | 4-8         |
| <b>4.2</b> | <b>Basic Wiring Diagrams . . . . .</b>                          | <b>4-9</b>  |
| <b>4.3</b> | <b>Wiring the Power Supply to the SERVOPACK . . . . .</b>       | <b>4-11</b> |
| 4.3.1      | Terminal Symbols and Terminal Names . . . . .                   | 4-11        |
| 4.3.2      | Wiring Procedure for Main Circuit Connector . . . . .           | 4-13        |
| 4.3.3      | Power ON Sequence . . . . .                                     | 4-14        |
| 4.3.4      | Power Supply Wiring Diagrams . . . . .                          | 4-15        |
| 4.3.5      | Wiring Regenerative Resistors . . . . .                         | 4-17        |
| 4.3.6      | Wiring Reactors for Harmonic Suppression . . . . .              | 4-18        |
| <b>4.4</b> | <b>Wiring Servomotors . . . . .</b>                             | <b>4-19</b> |
| 4.4.1      | Terminal Symbols and Terminal Names . . . . .                   | 4-19        |
| 4.4.2      | Pin Arrangement of Encoder Connectors (CN2A and CN2B) . . . . . | 4-19        |
| 4.4.3      | Wiring the SERVOPACK to the Encoder . . . . .                   | 4-20        |
| 4.4.4      | Wiring the SERVOPACK to the Holding Brake . . . . .             | 4-33        |

|            |  |             |
|------------|--|-------------|
| <b>4.5</b> | <b>Connecting I/O Signals</b>                          | <b>4-36</b> |
| 4.5.1      | I/O Signal Connector (CN1) Names and Functions         | 4-36        |
| 4.5.2      | I/O Signal Connector (CN1) Pin Arrangement             | 4-38        |
| 4.5.3      | I/O Signal Wiring Examples                             | 4-39        |
| 4.5.4      | I/O Circuits   | 4-41        |
| <b>4.6</b> | <b>Connecting Safety Function Signals</b>              | <b>4-43</b> |
| 4.6.1      | Pin Arrangement of Safety Function Signals (CN8A/CN8B) | 4-43        |
| 4.6.2      | I/O Circuits   | 4-44        |
| <b>4.7</b> | <b>Connecting EtherCAT Communications Cables</b>       | <b>4-46</b> |
| 4.7.1      | EtherCAT Connectors (RJ45)                             | 4-46        |
| 4.7.2      | Ethernet Communications Cables                         | 4-47        |
| <b>4.8</b> | <b>Connecting the Other Connectors</b>                 | <b>4-48</b> |
| 4.8.1      | Serial Communications Connector (CN3)                  | 4-48        |
| 4.8.2      | Computer Connector (CN7)                               | 4-48        |
| 4.8.3      | Analog Monitor Connector (CN5)                         | 4-48        |

## 4.1

## Wiring and Connecting SERVOPACKs

## 4.1.1 General Precautions

**DANGER**

- Do not change any wiring while power is being supplied. There is a risk of electric shock or injury.

**WARNING**

- Wiring and inspections must be performed only by qualified engineers. There is a risk of electric shock or product failure.
- Check all wiring and power supplies carefully. Incorrect wiring or incorrect voltage application to the output circuits may cause short-circuit failures. If a short-circuit failure occurs as a result of any of these causes, the holding brake will not work. This could damage the machine or cause an accident that may result in death or injury.
- Connect the AC and DC power supplies to the specified SERVOPACK terminals.
  - Connect an AC power supply to the L1, L2, and L3 terminals on the SERVOPACK.
  - Connect a DC power supply to the B1 and  $\ominus$  2 terminals and the 24 V and 0 V terminals on the SERVOPACK.
 There is a risk of failure or fire.

**CAUTION**

- Wait for at least six minutes after turning OFF the power supply and then make sure that the CHARGE indicator is not lit before starting wiring or inspection work. Do not touch the power supply terminals while the CHARGE lamp is lit after turning OFF the power supply because high voltage may still remain in the SERVOPACK. There is a risk of electric shock.
- Observe the precautions and instructions for wiring and trial operation precisely as described in this document. Failures caused by incorrect wiring or incorrect voltage application in the brake circuit may cause the SERVOPACK to fail, damage the equipment, or cause an accident resulting in death or injury.
- Check the wiring to be sure it has been performed correctly. Connectors and pin layouts are sometimes different for different models. Always confirm the pin layouts in technical documents for your model before operation. There is a risk of failure or malfunction.
- Connect wires to power supply terminals and motor connection terminals securely with the specified methods and tightening torque. Insufficient tightening may cause wires and terminal blocks to generate heat due to faulty contact, possibly resulting in fire.
- Use shielded twisted-pair cables or screened unshielded multi-twisted-pair cables for I/O Signal Cables and Encoder Cables.
- The maximum wiring length is 10 m for Control Power Supply Cables (+24 V, 0 V), 3 m for I/O Signal Cables, and 50 m for Encoder Cables or Servomotor Main Circuit Cables.
- Observe the following precautions when wiring the SERVOPACK's main circuit terminals.
  - Turn ON the power supply to the SERVOPACK only after all wiring, including the main circuit terminals, has been completed.
  - If a connector is used for the main circuit terminals, remove the main circuit connector from the SERVOPACK before you wire it.
  - Insert only one wire per insertion hole in the main circuit terminals.
  - When you insert a wire, make sure that the conductor wire (e.g., whiskers) does not come into contact with adjacent wires.
- Install molded-case circuit breakers and other safety measures to provide protection against short circuits in external wiring. There is a risk of fire or failure.

## NOTICE

- **Whenever possible, use the Cables specified by Yaskawa.**  
If you use any other cables, confirm the rated current and application environment of your model and use the wiring materials specified by Yaskawa or equivalent materials.
- **Securely tighten cable connector screws and lock mechanisms.**  
Insufficient tightening may result in cable connectors falling off during operation.
- **Do not bundle power lines (e.g., the Main Circuit Cable) and low-current lines (e.g., the I/O Signal Cables or Encoder Cables) together or run them through the same duct. If you do not place power lines and low-current lines in separate ducts, separate them by at least 30 cm.**  
If the cables are too close to each other, malfunctions may occur due to noise affecting the low-current lines.
- **Install a battery at either the host controller or on the Encoder Cable.**  
If you install batteries both at the host controller and on the Encoder Cable at the same time, you will create a loop circuit between the batteries, resulting in a risk of damage or burning.
- **When connecting a battery, connect the polarity correctly.**  
There is a risk of battery rupture or encoder failure.
- **If you use an External Regenerative Resistor or External Dynamic Brake Resistor, use cable ties, clamps, or other means to secure the resistor so that the connectors or terminal blocks inside the SERVOPACK will not be affected even if the resistor is subjected to vibration or shock.**  
There is a risk of SERVOPACK damage.



Important

- Use a molded-case circuit breaker or fuse to protect the main circuit. The SERVOPACK connects directly to a commercial power supply; it is not isolated through a transformer or other device. Always use a molded-case circuit breaker or fuse to protect the Servo System from accidents involving different power system voltages or other accidents.
- Install an earth leakage breaker. The SERVOPACK does not have a built-in ground fault protective circuit. To configure a safer system, install a ground fault detector against overloads and short-circuiting, or install a ground fault detector combined with a molded-case circuit breaker.
- Do not turn the power supply ON and OFF more than necessary.
  - Do not use the SERVOPACK for applications that require the power supply to turn ON and OFF frequently. Such applications will cause elements in the SERVOPACK to deteriorate.
  - After you have started actual operation, allow at least one hour between turning the power supply ON and OFF (as a guideline).

To ensure safe, stable application of the Servo System, observe the following precautions when wiring.

- Use the Cables specified by Yaskawa. Design and arrange the system so that each cable is as short as possible.  
Refer to the catalog for information on the specified cables.
- The signal cable conductors are as thin as 0.2 mm<sup>2</sup> or 0.3 mm<sup>2</sup>. Do not subject them to excessive bending stress or tension.



## 4.1.2 Countermeasures against Noise



Important

The SERVOPACK is designed as an industrial device. It therefore provides no measures to prevent radio interference. The SERVOPACK uses high-speed switching elements in the main circuit. Therefore peripheral devices may be affected by switching noise.

If the equipment is to be used near private houses or if radio interference is a problem, take countermeasures against noise.

The SERVOPACK uses microprocessors. Therefore, it may be affected by switching noise from peripheral devices.



To prevent the noise from the SERVOPACK or the peripheral devices from causing malfunctions of any devices, take the following countermeasures against noise as required.

- Install the input reference device and Noise Filter as close to the SERVOPACK as possible.
- Always install a Surge Absorber for relays, solenoids, and Magnetic Contactor coils.
- Do not place the following cables in the same duct or bundle them together. Also, separate the cables from each other by at least 30 cm.
  - Main Circuit Cables and I/O Signal Cables
  - Main Circuit Cables and Encoder Cables
- Do not share the power supply with an electric welder or electrical discharge machine. If the SERVOPACK is placed near a high-frequency generator, install Noise Filters on the input side on the Main Circuit Power Supply Cable and Control Power Supply Cable even if the same power supply is not shared with the high-frequency generator. Refer to the following section for information on connecting Noise Filters.
  - ☞ *Noise Filters* on page 4-6
- Implement suitable grounding measures. Refer to the following section for information on grounding measures.
  - ☞ *4.1.3 Grounding* on page 4-8

## Noise Filters

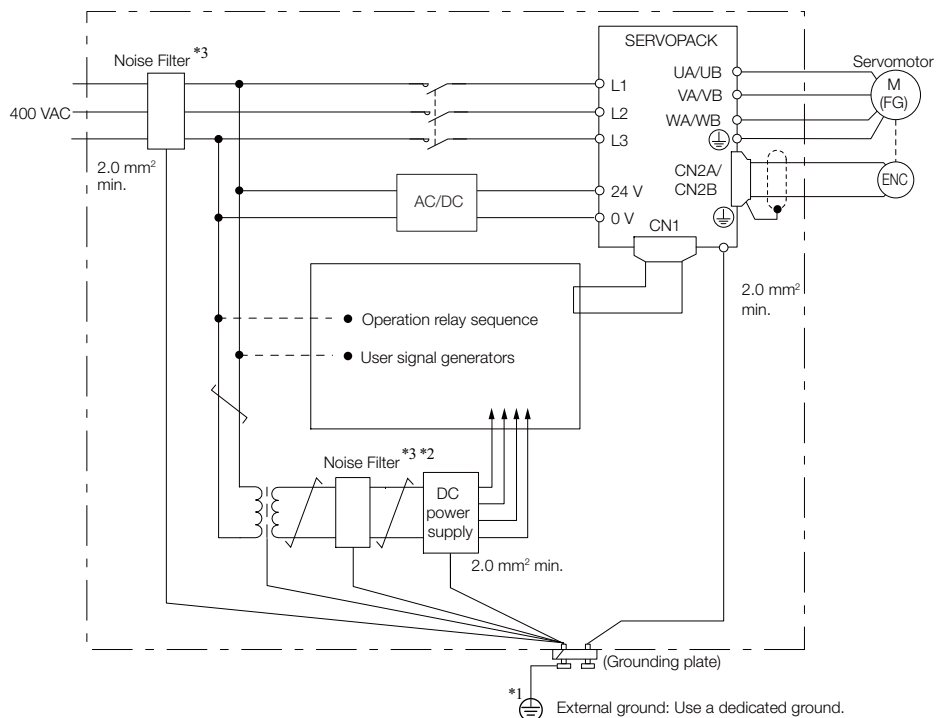
You must attach Noise Filters in appropriate places to protect the SERVOPACK from the adverse effects of noise. The following is an example of wiring for countermeasures against noise.



- \*1. For the ground wire, use a wire with a thickness of at least  $2.0\text{ mm}^2$  (preferably, flat braided copper wire).
- \*2. Whenever possible, use twisted-pair wires to wire all connections marked with .
- \*3. Refer to the following section for precautions when using Noise Filters.  
 **Noise Filter Wiring and Connection Precautions** on page 4-7

## Noise Filter Wiring and Connection Precautions

Always observe the following precautions when wiring or connecting Noise Filters.

- Separate input lines from output lines. Do not place input lines and output lines in the same duct or bundle them together.

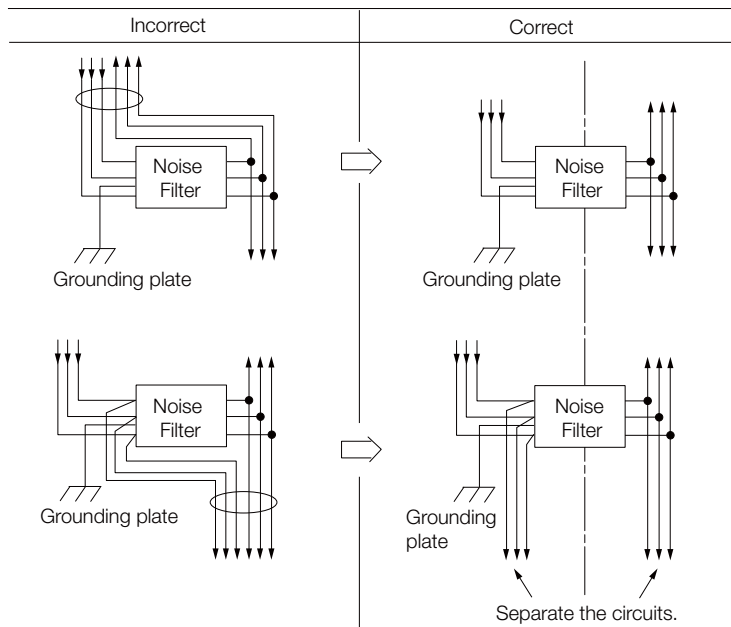

- Separate the Noise Filter ground wire from the output lines. Do not place the Noise Filter ground wire, output lines, and other signal lines in the same duct or bundle them together.

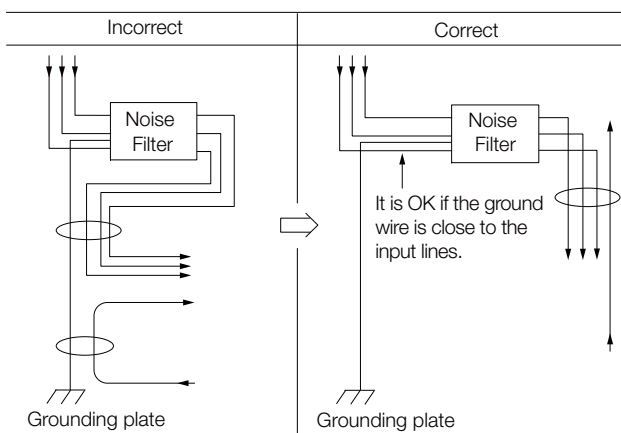

- Connect the Noise Filter ground wire directly to the grounding plate. Do not connect the Noise Filter ground wire to other ground wires.

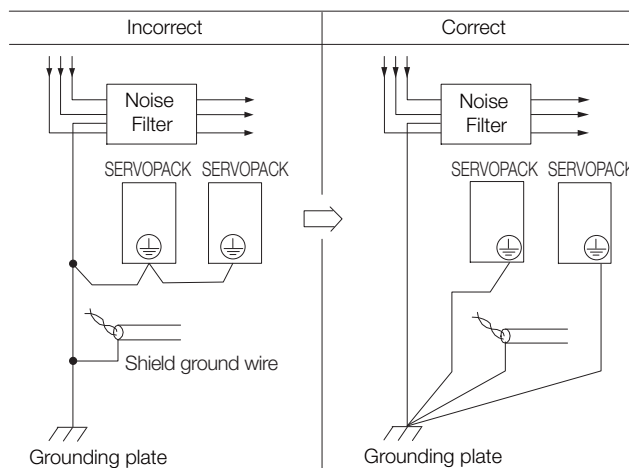

- If a Noise Filter is located inside a control panel, first connect the Noise Filter ground wire and the ground wires from other devices inside the control panel to the grounding plate for the control panel, then ground the plate.

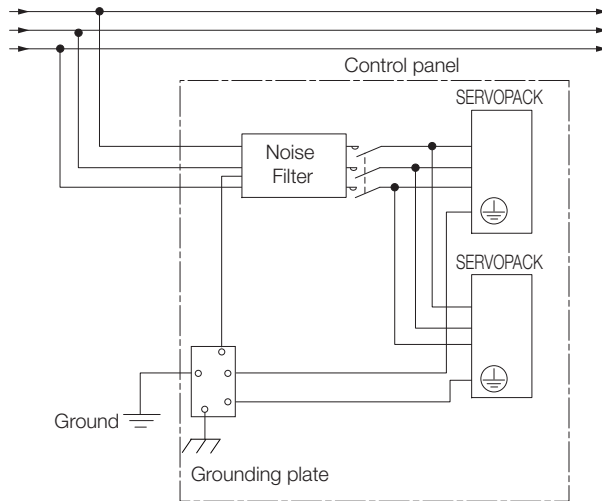

## 4.1.3 Grounding

Implement grounding measures as described in this section. Implementing suitable grounding measures will also help prevent malfunctions, which can be caused by noise.

Observe the following precautions when wiring the ground cable.

- Ground the SERVOPACK to a resistance of 10  $\Omega$  or less.
- Be sure to ground at one point only.
- Ground the Servomotor directly if the Servomotor is insulated from the machine.

### Motor Frame Ground or Motor Ground

If you ground the Servomotor through the machine, a current resulting from switching noise can flow from the main circuit of the SERVOPACK through the stray capacitance of the Servomotor. To prevent this, always connect the motor frame terminal (FG) or ground terminal (FG) of the Servomotor to the ground terminal (⊕) on the SERVOPACK. Also be sure to ground the ground terminal (⊕).

Ground both the Moving Coil and Magnetic Way of a Linear Servomotor.

### Noise on I/O Signal Cables

If noise enters the I/O Signal Cable, connect the shield of the I/O Signal Cable to the connector shell to ground it. If the Servomotor Main Circuit Cable is placed in a metal conduit, ground the conduit and its junction box. For all grounding, ground at one point only.

# 4.2 Basic Wiring Diagrams

This section provide the basic wiring diagrams. Refer to the reference sections given in the diagrams for details.

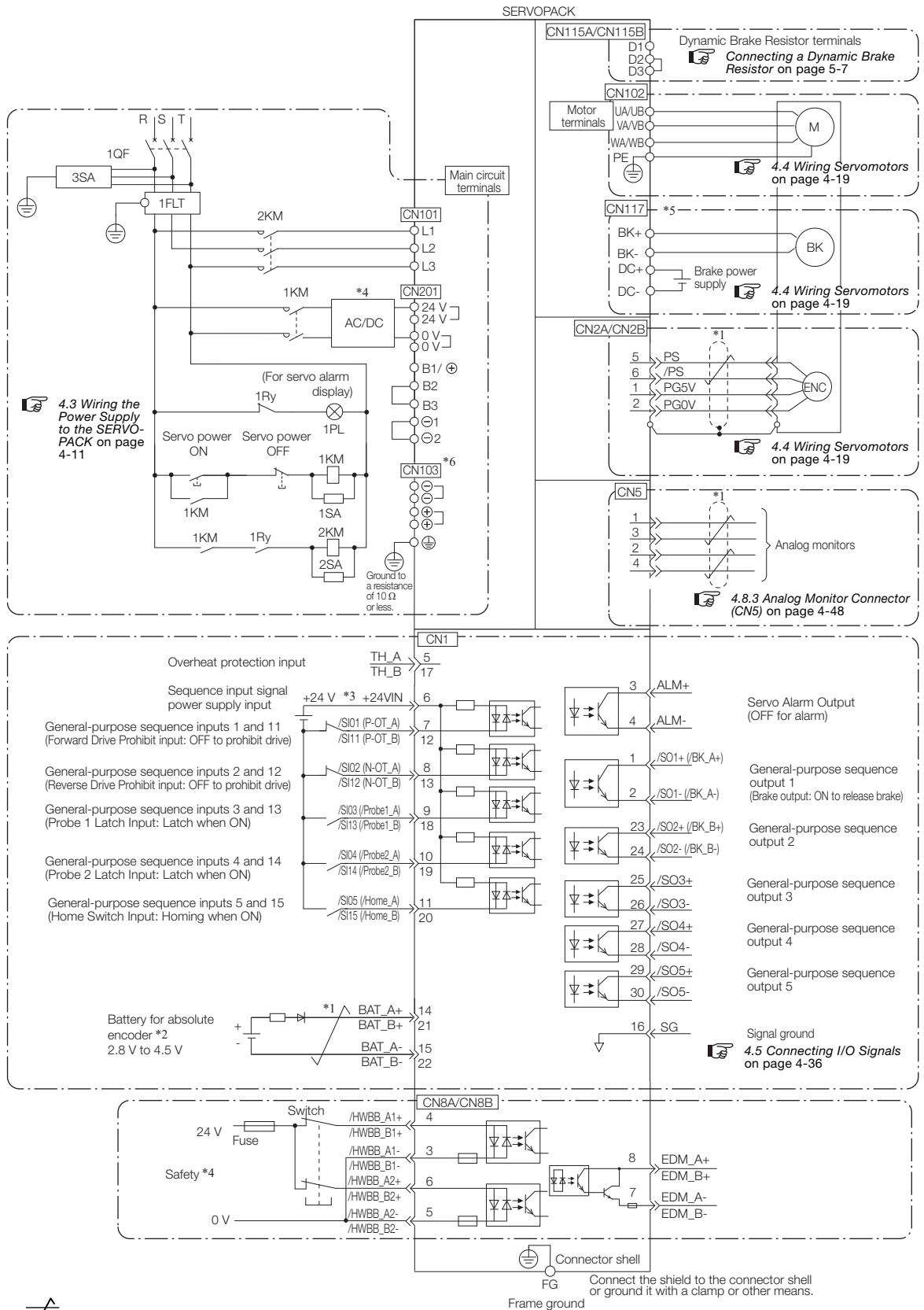

- \*1. represents twisted-pair wires.
- \*2. Connect these when using an absolute encoder. If the Encoder Cable with a Battery Case is connected, do not connect a backup battery.
- \*3. The 24-VDC power supply is not provided by Yaskawa. Use a 24-VDC power supply with double insulation or reinforced insulation.

- \*4. Use an SELV-compliant power supply according to EN/IEC 60950-1 to input 24 VDC to the control power supply input terminals.
- \*5. The CN117 connector is used for SERVOPACKs with built-in Servomotor brake control. SERVOPACKs without built-in Servomotor brake control do not have the CN117 connector.
- \*6. If using these terminals, contact your YASKAWA representative.

Note: 1. You can use parameter settings to change some of the I/O signal allocations. Refer to the following section for details.

 **7.1 I/O Signal Allocations on page 7-3**

2. If you use a 24-V brake, install a separate power supply for the 24-VDC power supply from other power supplies, such as the one for the I/O signals of the CN1 connector. If the power supply is shared, the I/O signals may malfunction.
3. Default settings are given in parentheses.

## 4.3

## Wiring the Power Supply to the SERVOPACK

Refer to the catalog for information on cables and peripheral devices.

## 4.3.1

## Terminal Symbols and Terminal Names

Use the main circuit connector on the SERVOPACK to wire the main circuit power supply and control circuit power supply to the SERVOPACK.





## CAUTION

- Wire all connections correctly according to the following table and specified reference information. There is a risk of SERVOPACK failure or fire if incorrect wiring is performed.

The SERVOPACKs have the following two types of main circuit power supply input specifications.

- Three-Phase, 400-VAC Power Supply Input

| Terminal Symbols               | Terminal Name   | Specifications and Reference  |
|--------------------------------|---|---|
| L1, L2, L3                     | Main circuit power supply input terminals for AC power supply input | Three-phase, 380 VAC to 480 VAC, -15% to +10%, 50 Hz/60 Hz  |
| 24 V                           | Control power supply terminals*1                                    | 24 VDC, -15% to +15%  |
| 0 V                            |   | 0 VDC   |
| B1, B2, B3                     | Regenerative Resistor terminal                                      |  <a href="#">4.3.5 Wiring Regenerative Resistors on page 4-17</a><br>If the internal Regenerative Resistor is insufficient, remove the lead or short bar between B2 and B3 and connect an External Regenerative Resistor between B1 and B2. The External Regenerative Resistor is not included. Obtain it separately.    |
| ⊖1, ⊖2                         | DC Reactor terminals for power supply harmonic suppression          |  <a href="#">4.3.6 Wiring Reactors for Harmonic Suppression on page 4-18</a><br>These terminals are used to connect a DC Reactor for power supply harmonic suppression.  |
| ⊖, ⊕                           | –   | None. (Do not connect anything to this terminal.)   |
| UA, UB, VA, VB, WA, WB, and PE | Servomotor terminals  | These are the $\Sigma$ -7W connection terminals for the Servomotor Main Circuit Cable (power line).<br>Note: Do not connect the PE terminal to anything other than a ground terminal.   |
| D1, D2, D3                     | Dynamic Brake Resistor terminals                                    | In the following cases, remove the lead or short bar between D2 and D3 and connect a Dynamic Brake Resistor between D1 and D2. <ul style="list-style-type: none"> <li>• To specify the brake torque when stopping with the dynamic brake</li> <li>• To use a larger load moment of inertia than in the standard specifications</li> </ul> The Dynamic Brake Resistor is not included. Obtain it separately. |
| DC+*3                          | Servomotor brake power supply terminals*2                           | 24 VDC  |
| DC-*3                          |   | 0 VDC   |
| BK+, BK-*3                     | Servomotor brake terminals  | Connect these terminals to the Servomotor's holding brake terminals. The holding brake terminals on the Servomotor do not have any polarity.  |
| ⊕                              | Ground terminal   | The ground terminals to prevent electric shock. Always connect this terminal.   |

\*1. Use an SELV-compliant power supply according to EN/IEC 60950-1 to input 24 VDC to the control power supply input terminals.

\*2. Make sure you check the brake specifications of the Servomotor for the 24-VDC power supply input to the motor brake power supply terminals.

\*3. SERVOPACKs without built-in Servomotor brake control do not have these terminals.

4.3.1 Terminal Symbols and Terminal Names

• DC Power Supply Input

| Terminal Symbols              | Terminal Name   | Specifications and Reference  |
|-------------------------------|---|---|
| 24 V                          | Control power supply terminals*1                                    | 24 VDC, -15% to +15%  |
| 0 V                           |   | 0 VDC   |
| B1*2                          | Main circuit power supply input terminals for DC power supply input | 513 VDC to 648 VDC, -15% to +10%  |
| ⊖2*2                          |   | 0 VDC   |
| L1, L2, L3, B2, B3, ⊖1, ⊕, ⊕  | –   | None. (Do not connect anything to these terminals.)   |
| UA, UB, VA, VB, WA, WB and PE | Servomotor terminals  | These are the $\Sigma$ -7W connection terminals for the Servomotor Main Circuit Cable (power line).<br>Note: Do not connect the PE terminal to anything other than a ground terminal.   |
| D1, D2, D3                    | Dynamic Brake Resistor terminals                                    | In the following cases, remove the lead or short bar between D2 and D3 and connect a Dynamic Brake Resistor between D1 and D2. <ul style="list-style-type: none"> <li>• To specify the brake torque when stopping with the dynamic brake</li> <li>• To use a larger load moment of inertia than in the standard specifications</li> </ul> The Dynamic Brake Resistor is not included. Obtain it separately. |
| DC+*4                         | Servomotor brake power supply terminals*3                           | 24 VDC  |
| DC-*4                         |   | 0 VDC   |
| BK+, BK-*4                    | Servomotor brake terminals  | Connect these terminals to the Servomotor's holding brake terminals. The holding brake terminals on the Servomotor do not have any polarity.  |
| ⊕                             | Ground terminal   | This is the ground terminal to prevent electric shock. Always connect this terminal.  |

\*1. Use an SELV-compliant power supply according to EN/IEC 60950-1 to input 24 VDC to the control power supply input terminals.

\*2. If using these terminals, contact your YASKAWA representative.

\*3. Make sure you check the brake specifications of the Servomotor for the 24-VDC power supply input to the motor brake power supply terminals.

\*4. SERVOPACKs without built-in Servomotor brake control do not have these terminals.

If you use a DC power supply input to the SERVOPACK, make sure to set parameter Pn001 to n.□1□□ (DC power supply input supported) before inputting the power supply. Refer to the following section for details.

 6.2 Power Supply Type Settings for the Main Circuit on page 6-11



## 4.3.2 Wiring Procedure for Main Circuit Connector

- Required Items: Phillips or flat-blade screwdriver

| Terminal Symbols               | Screwdriver Type       | Screwdriver End Dimensions<br>Thickness × Width [mm] | Wire Stripping Length [mm] |
|--------------------------------|------------------------|--|----------------------------|
| L1, L2, L3, B1, B2, B3, -1, -2 | Flat-blade             | 0.6 × 3.5  | 7                          |
| UA, UB, VA, VB, WA, WB, and PE | Phillips or flat-blade |  | 7                          |
| 24 V, 0 V                      | Flat-blade             |  | 10                         |

1. Prepare the connector that was provided with the SERVOPACK.
2. Remove the sheath from the wire to connect.

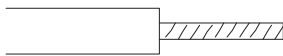

3. Open the wire insertion hole on the terminal connector with the screwdriver.

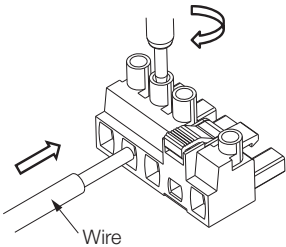
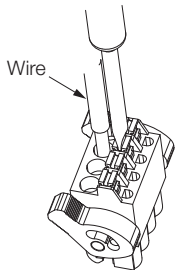
| Main Circuit Terminals and Motor Terminals   | Control Power Supply Terminals and Servomotor Brake Terminals   |
|--|---|
| <p>Insert the conductor of the wire into the wire insertion hole, insert the screwdriver into the screwdriver insertion hole, and tighten the screw.</p>  | <p>Press the lever with a screwdriver or your fingertip and insert the conductor of the wire into the wire insertion hole. After you insert conductor, release the screwdriver or your fingertip.</p>  |

4. Make all other connections in the same way.
5. When you have completed wiring, attach the connector to the SERVOPACK.
6. Press the connector all the way to the back and lock it with the lock lever.

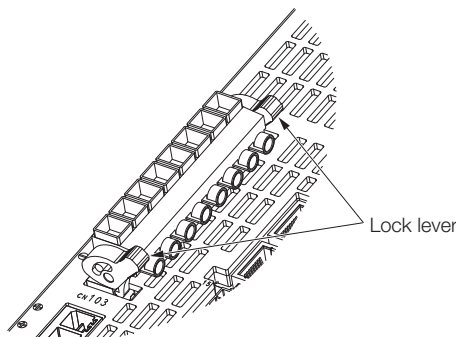

## 4.3.3 Power ON Sequence

Consider the following points when you design the power ON sequence.

- The ALM (Servo Alarm) signal is output for up to five seconds when the control power supply is turned ON. Take this into consideration when you design the power ON sequence, and turn ON the main circuit power supply to the SERVOPACK when the ALM signal is OFF (alarm cleared).

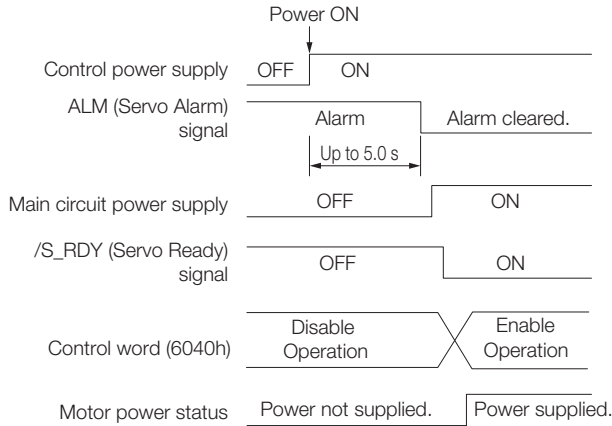

**Information** If the servo ON state cannot be achieved by inputting the Servo ON command (Enable Operation command), the /S\_RDY signal is not ON. Check the status of the /S\_RDY signal. Refer to the following section for details.

7.1.6 /S-RDY (Servo Ready) Signal on page 7-12

- Design the power ON sequence so that main circuit power supply is turned OFF when an ALM (Servo Alarm) signal is output.
- Make sure that the power supply specifications of all parts are suitable for the input power supply.
- Allow at least 1 s after the power supply is turned OFF before you turn it ON again.

**Important** Turn ON the control power supply before the main circuit power supply, or turn ON the control power supply and the main circuit power supply at the same time. When turning OFF the power supply, turn OFF the main circuit power supply first, and then turn OFF the control power supply.

**WARNING**

- Even after you turn OFF the power supply, a high residual voltage may still remain in the SERVOPACK. To prevent electric shock, do not touch the power supply terminals after you turn OFF the power. When the voltage is discharged, the CHARGE indicator will turn OFF. Make sure the CHARGE indicator is OFF before you start wiring or inspection work.

## 4.3.4 Power Supply Wiring Diagrams

### Using Only One SERVOPACK

- Wiring Example for Three-Phase, 400-VAC Power Supply Input: SGD7W-2R6D and -5R4D

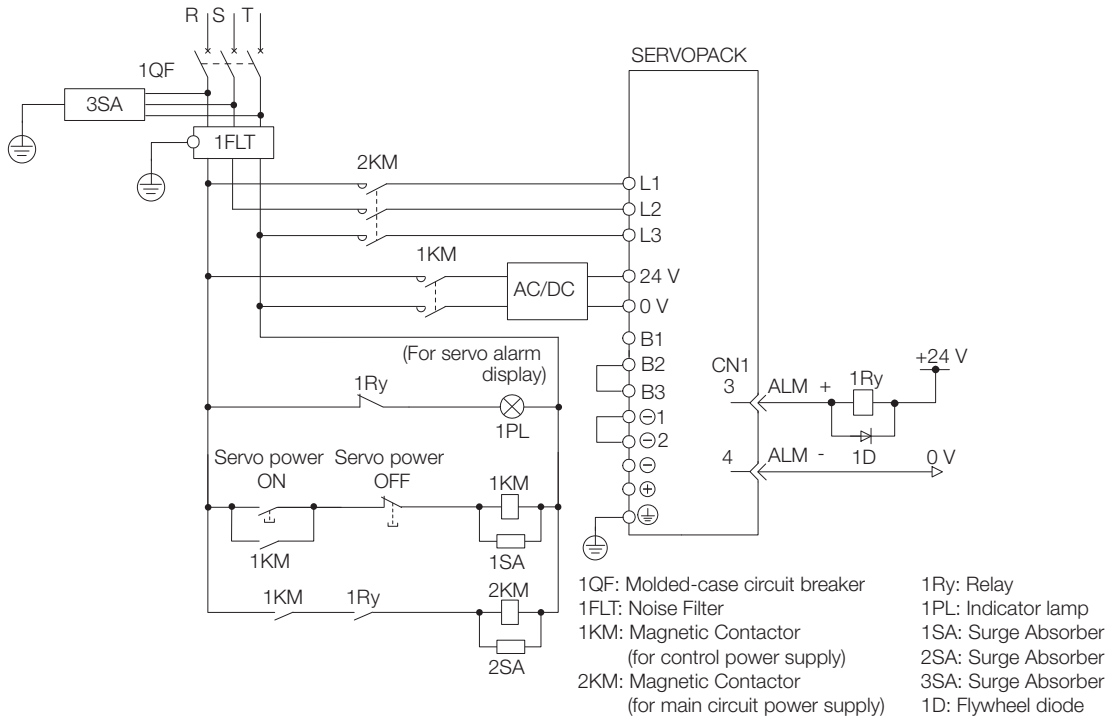

- Wiring Example for DC Power Supply Input: SGD7W-2R6D and -5R4D

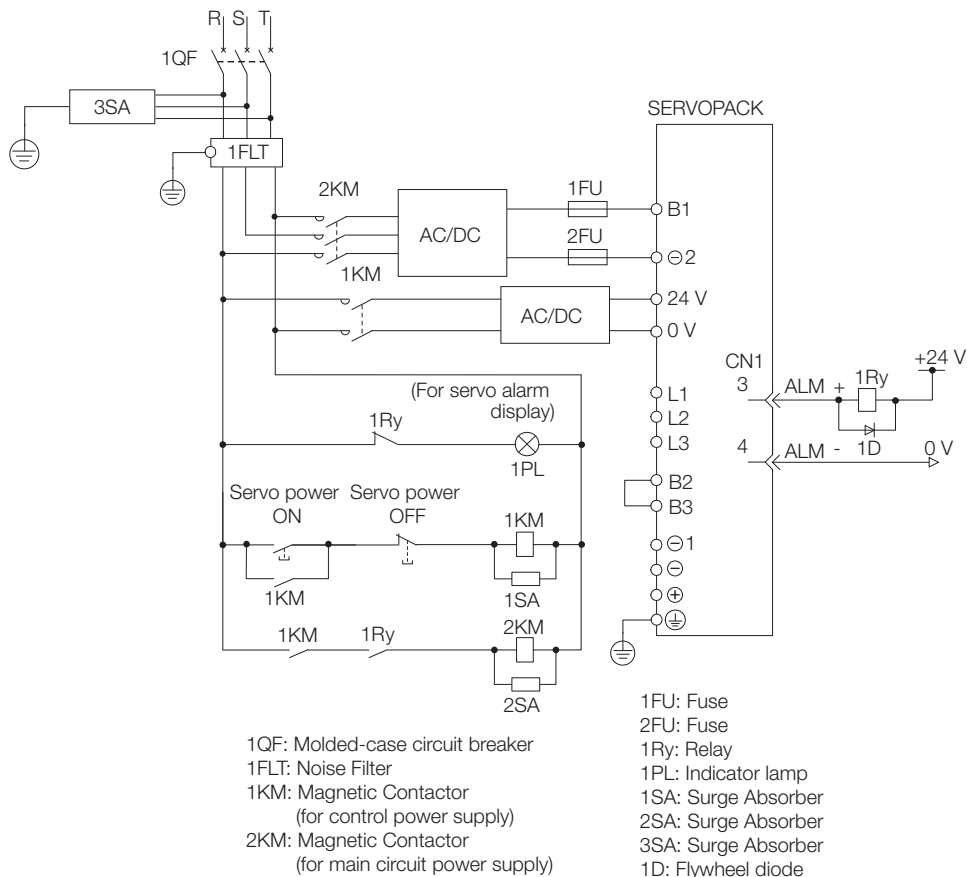

## Using More Than One SERVOPACK

Connect the ALM (Servo Alarm) output for these SERVOPACKs in series to operate the alarm detection relay (1RY).

When a SERVOPACK alarm is activated, the ALM output signal transistor turns OFF.

The following diagram shows the wiring to stop all of the Servomotors when there is an alarm for any one SERVOPACK.

More than one SERVOPACK can share a single Noise Filter. However, always select a Noise Filter that has a large enough capacity to handle the total power supply capacity of all the SERVOPACKs. Be sure to consider the load conditions.

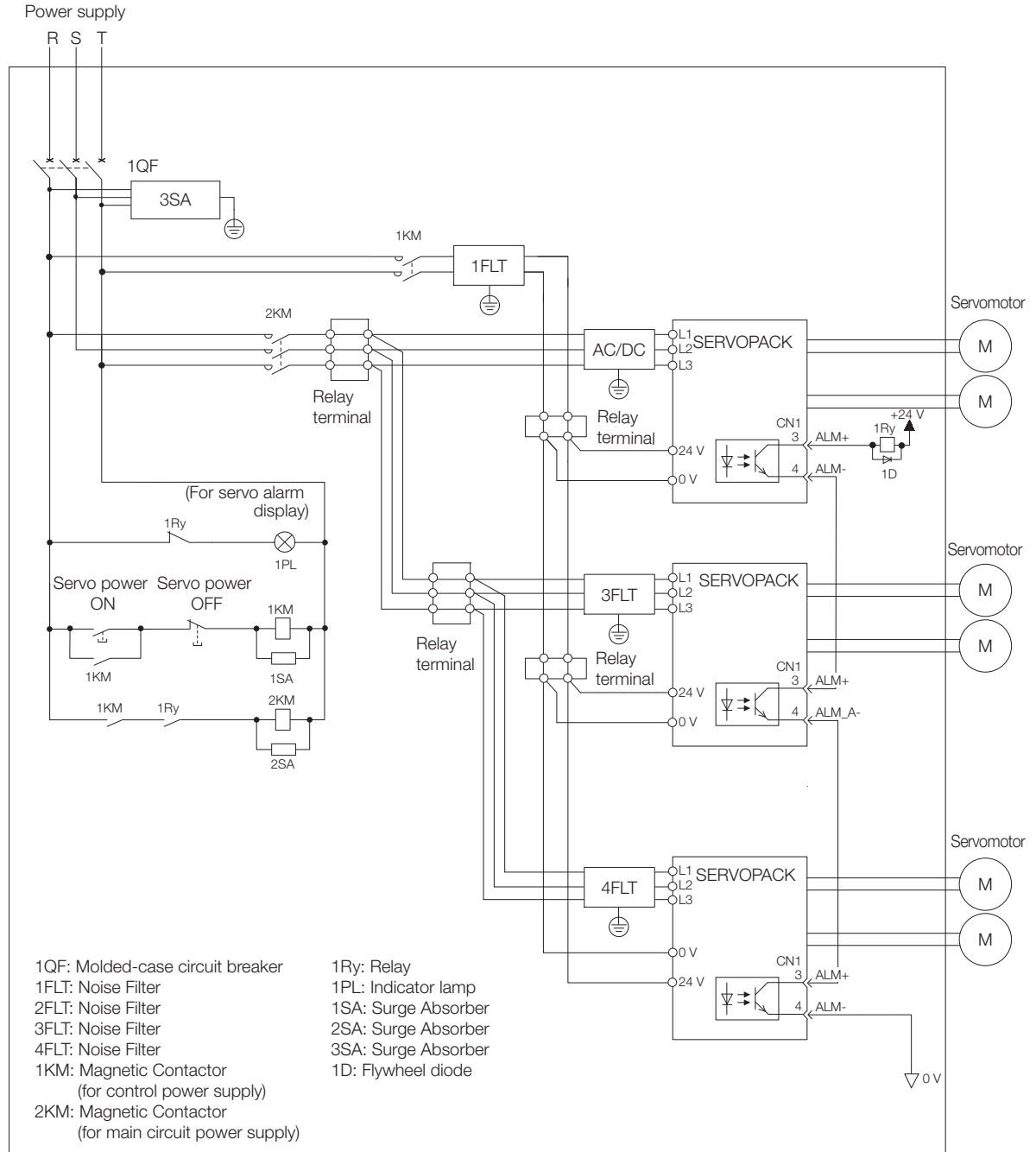

To comply with UL/cUL standards, you must install a branch circuit protective device at the power supply input section to each SERVOPACK. Refer to the following document for details.

Σ-7-Series Σ-7S and Σ-7W SERVOPACK with 400 V-Input Power Safety Precautions (Manual No.: TOMP C710828 02)

## 4.3.5 Wiring Regenerative Resistors

This section describes how to connect External Regenerative Resistors.

Refer to the catalog to select External Regenerative Resistors.



### WARNING

- Be sure to wire Regenerative Resistors correctly. Do not connect B1/⊕ and B2. Doing so may result in fire or damage to the Regenerative Resistor or SERVOPACK.

### Connecting Regenerative Resistors

1. Remove the wire connected between the B2 and B3 terminals.

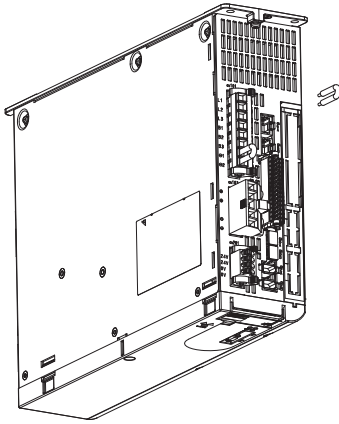

2. Connect the External Regenerative Resistor between the B1 and B2 terminals on the SERVOPACK.

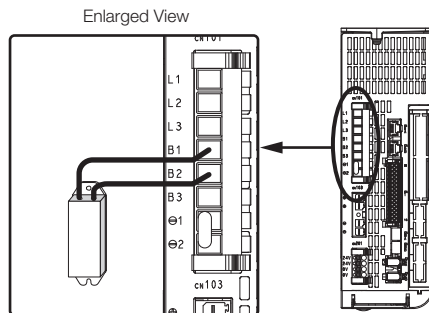

3. Set Pn600 (Regenerative Resistor Capacity) and Pn603 (Regenerative Resistor Resistance). Refer to the following section for details on the settings.

6.17 Setting the Regenerative Resistor Capacity on page 6-54

---

## 4.3.6 Wiring Reactors for Harmonic Suppression

---

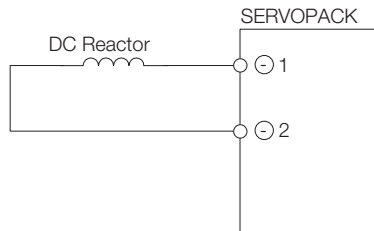

You can connect a reactor for harmonic suppression to the SERVOPACK when power supply harmonic suppression is required. Connection terminals  $\ominus 1$  and  $\ominus 2$  for a DC Reactor are connected when the SERVOPACK is shipped. Remove the lead wire and connect a DC Reactor as shown in the following diagram.



## 4.4 Wiring Servomotors

### 4.4.1 Terminal Symbols and Terminal Names

The SERVOPACK terminals or connectors that are required to connect the SERVOPACK to a Servomotor are given below.

| Terminal/Connector Symbols  | Terminal/Connector Name         | Remarks   |
|---|---------------------------------|---|
| CN102A (UA, VA, and WA)   | Servomotor terminals for axis A | Refer to the following section for the wiring procedure.<br> <i>4.3.2 Wiring Procedure for Main Circuit Connector on page 4-13</i> |
| CN102B (UB, VB, and WB)   | Servomotor terminals for axis B |   |
|  | Ground terminal                 | –   |
| CN2A  | Encoder connector for axis A    | –   |
| CN2B  | Encoder connector for axis B    | –   |

| Connector Symbols  | Terminal Name                               | Specification  |
|--------------------|---|--|
| CN115A (D1 and D2) | Dynamic Brake Resistor terminals for axis A | These terminals are connected to an External Dynamic Brake Resistor. |
| CN115B (D1 and D2) | Dynamic Brake Resistor terminals for axis B |  |

### 4.4.2 Pin Arrangement of Encoder Connectors (CN2A and CN2B)

- When Using a Rotary Servomotor

| Pin No. | Signal   | Function                         |
|---------|----------|----------------------------------|
| 1       | PG5V     | Encoder power supply +5 V        |
| 2       | PG0V     | Encoder power supply 0 V         |
| 3       | BAT (+)* | Battery for absolute encoder (+) |
| 4       | BAT (-)* | Battery for absolute encoder (-) |
| 5       | PS       | Serial data (+)                  |
| 6       | /PS      | Serial data (-)                  |
| Shell   | Shield   | –                                |

\* You do not need to wire these pins for an incremental encoder.

- When Using a Linear Servomotor

| Pin No. | Signal | Function                         |
|---------|--------|----------------------------------|
| 1       | PG5V   | Linear encoder power supply +5 V |
| 2       | PG0V   | Linear encoder power supply 0 V  |
| 3       | –      | – (Do not use.)                  |
| 4       | –      | – (Do not use.)                  |
| 5       | PS     | Serial data (+)                  |
| 6       | /PS    | Serial data (-)                  |
| Shell   | Shield | –                                |

## 4.4.3 Wiring the SERVOPACK to the Encoder

### When Using an Absolute Encoder

If you use an absolute encoder, use an Encoder Cable with a JUSP-BA01-E Battery Case or install a battery on the host controller.

Refer to the following section for the battery replacement procedure.

 15.1.3 Replacing the Battery on page 15-3

- Wiring Example When Using an Encoder Cable with a Battery Case

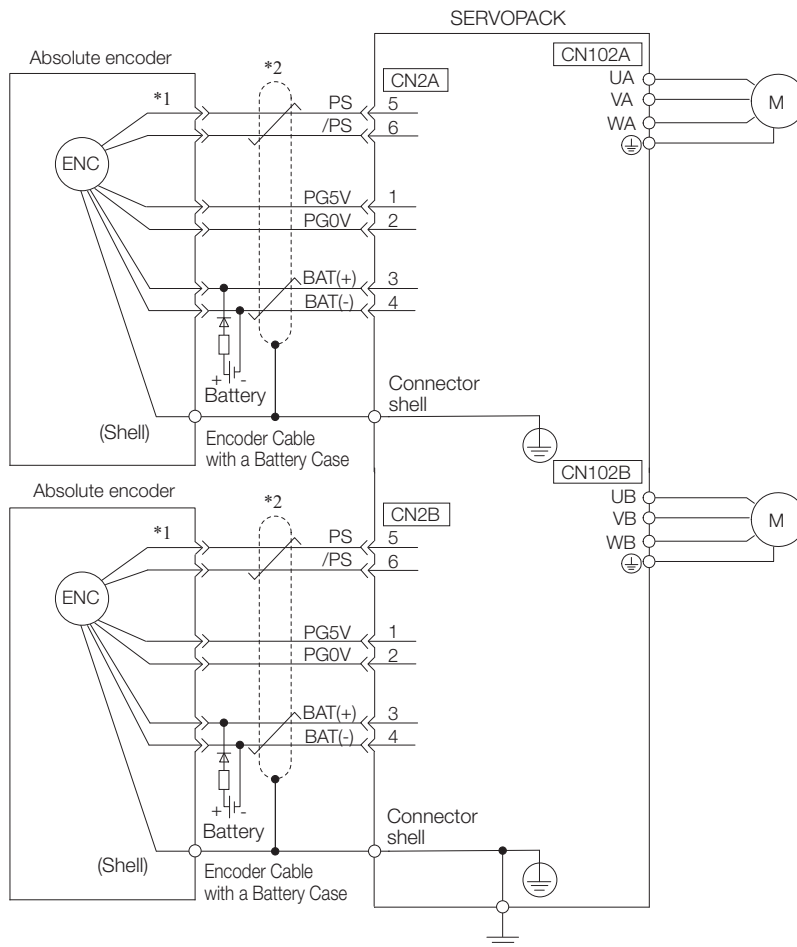

\*1. The absolute encoder pin numbers for wiring the connector depend on the Servomotor that you use.

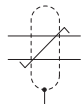
\*2.  represents a shielded twisted-pair cable.



• Wiring Example When Installing a Battery on the Host Controller

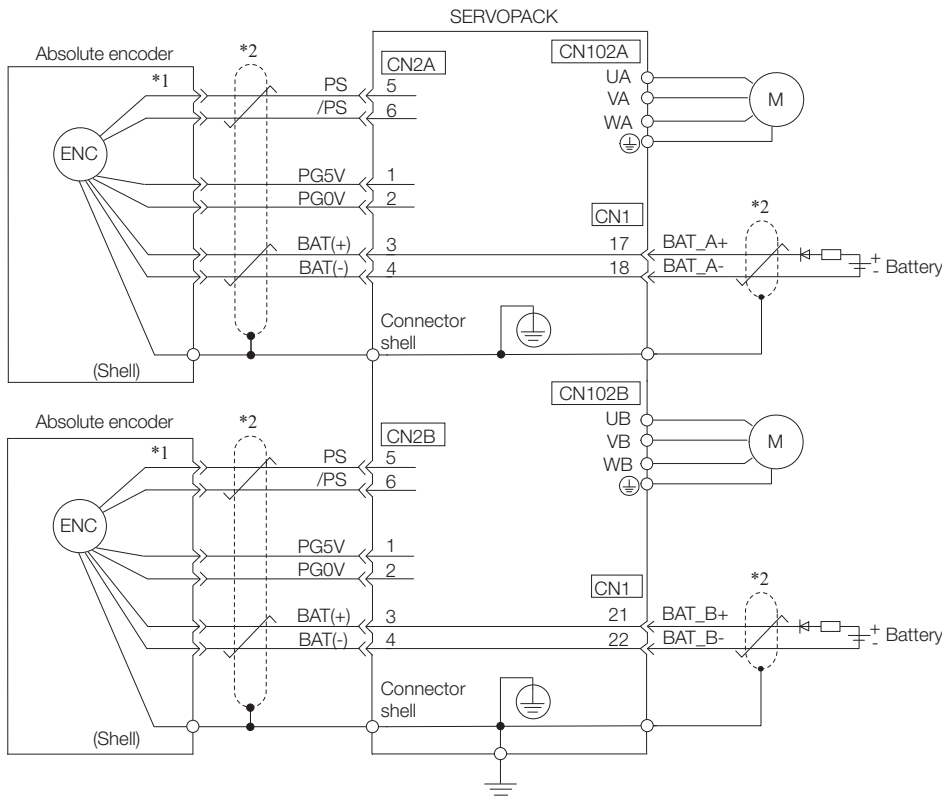

\*1. The absolute encoder pin numbers for wiring the connector depend on the Servomotor that you use.

\*2. represents a shielded twisted-pair cable.



Important

- When Installing a Battery on the Encoder Cable  
Use the Encoder Cable with a Battery Case that is specified by Yaskawa. Refer to the catalog for details.
- When Installing a Battery on the Host Controller  
Insert a diode near the battery to prevent reverse current flow.

|                        |  |   |
|------------------------|--|---|
| <b>Circuit Example</b> | Required Component Specifications <ul style="list-style-type: none"> <li>• Schottky Diode                         <ul style="list-style-type: none"> <li>Reverse Voltage: <math>V_r \geq 40\text{ V}</math></li> <li>Forward Voltage: <math>V_f \leq 0.37\text{ V}</math></li> <li>Reverse current: <math>I_r \leq 5\ \mu\text{A}</math></li> <li>Junction temperature: <math>T_j \geq 125^\circ\text{C}</math></li> </ul> </li> </ul> | <ul style="list-style-type: none"> <li>• Resistor                         <ul style="list-style-type: none"> <li>Resistance: <math>22\ \Omega</math></li> <li>Tolerance: <math>\pm 5\%</math> max.</li> <li>Rated power: <math>0.25\text{ W min.}</math></li> </ul> </li> </ul> |
|------------------------|--|---|

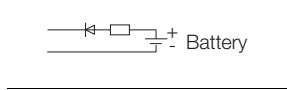

## When Using an Incremental Encoder

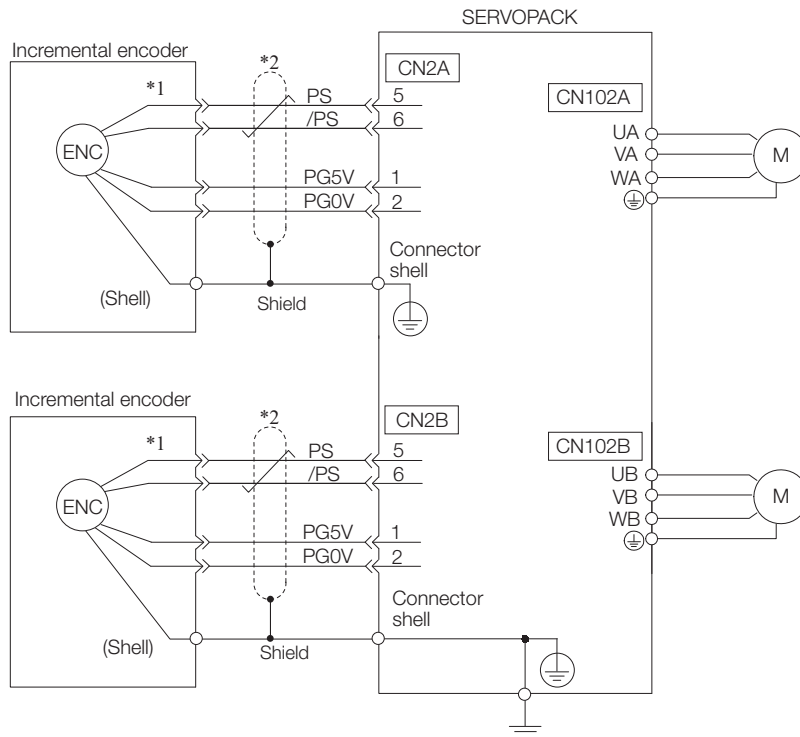

\*1. The incremental encoder pin numbers for wiring the connector depend on the Servomotor that you use.

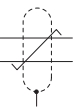
\*2.  represents a shielded twisted-pair cable.

## When Using an Absolute Linear Encoder

The wiring depends on the manufacturer of the linear encoder.

### ◆ Connections to Linear Encoder from Dr. JOHANNES HEIDENHAIN GmbH

#### ■ LIC4100 Series, LIC2100 Series, LC115, and LC415

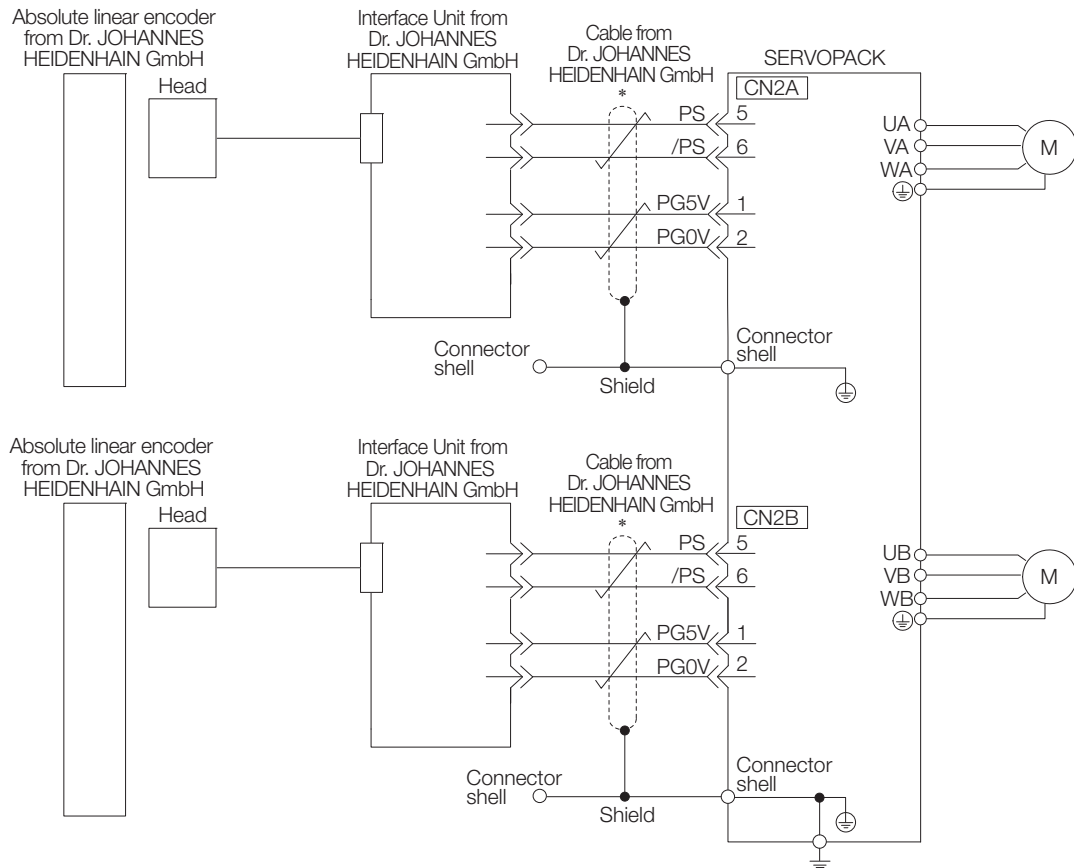

\* represents a shielded twisted-pair cable.

**Information** Sales of the interface unit EIB3391Y with the LIC4100 and LIC2100 series have ended due to the release of the LIC4190, LIC3190, and LIC2190 series.

■ LIC4190, LIC3190, and LIC2190 Series

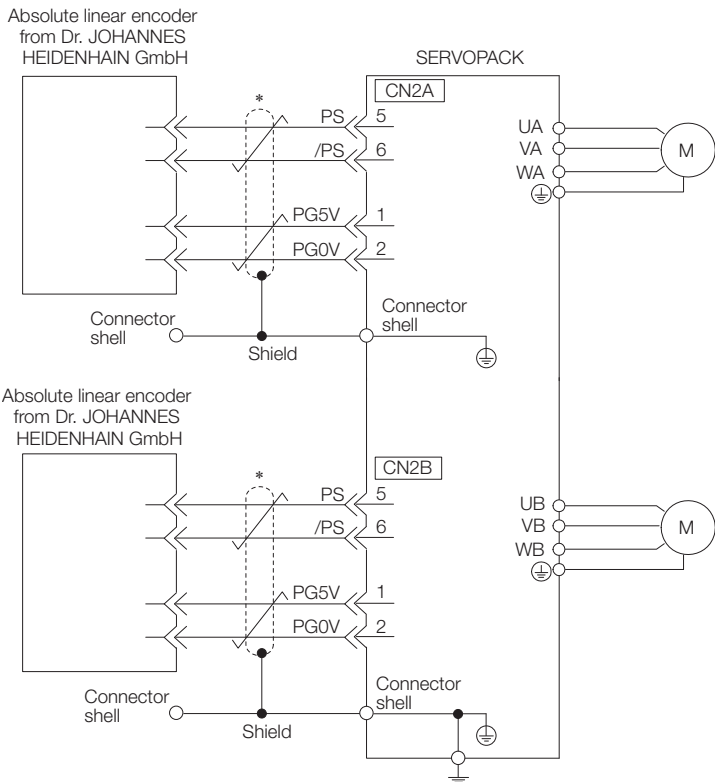

\*  represents a shielded twisted-pair cable.

◆ Connections to Linear Encoder from RSF Elektronik GmbH

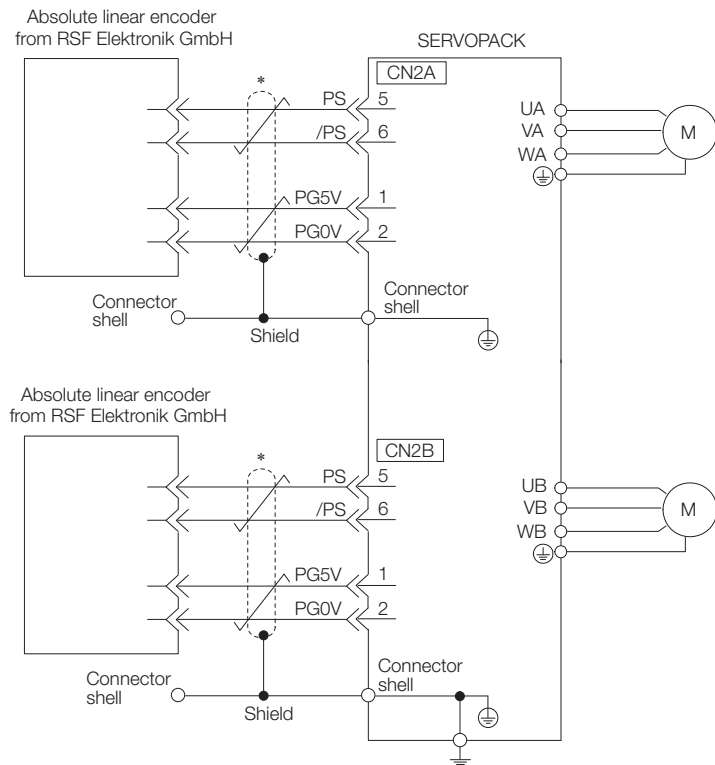

\*  represents a shielded twisted-pair cable.

◆ Connections to Linear Encoder from Mitutoyo Corporation

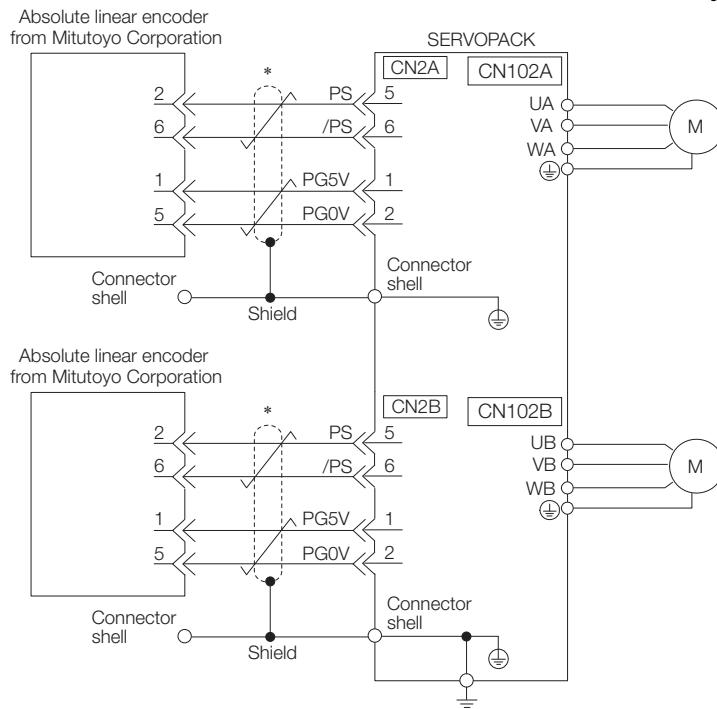

\*  represents a shielded twisted-pair cable.

◆ Connections to Absolute Linear Encoder from Renishaw PLC

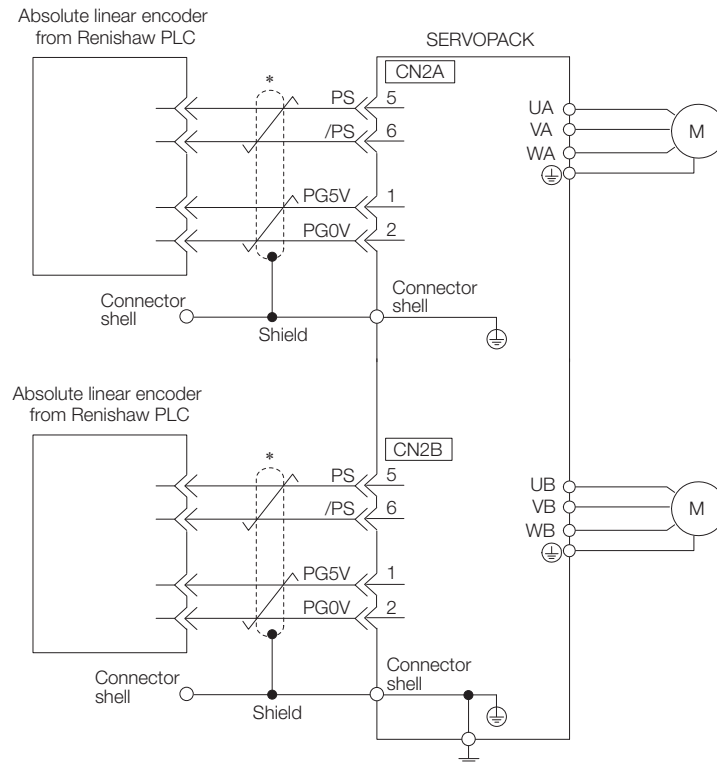

\*  represents a shielded twisted-pair cable.

◆ Connections to Linear Encoder from RLS d.o.o.

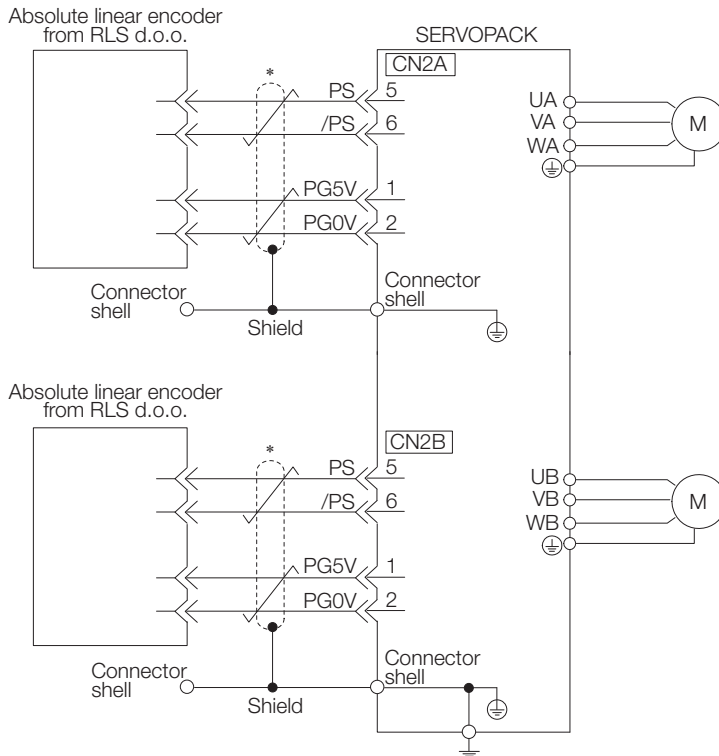

\*  represents a shielded twisted-pair cable.

◆ Connections to Absolute Linear Encoder from Magnescale Co., Ltd.

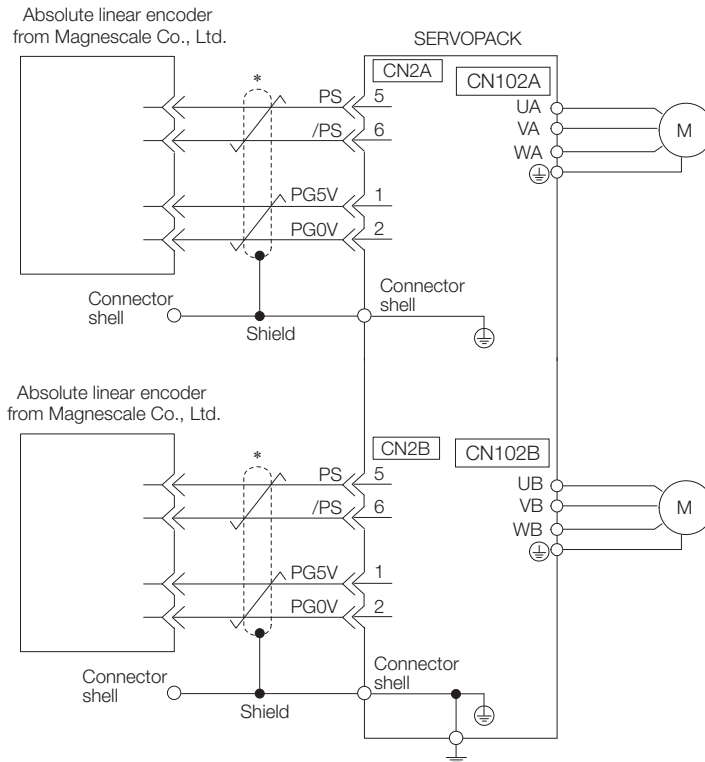

\*  represents a shielded twisted-pair cable.

◆ Connections to Absolute Linear Encoder from Fagor Automation S. Coop.

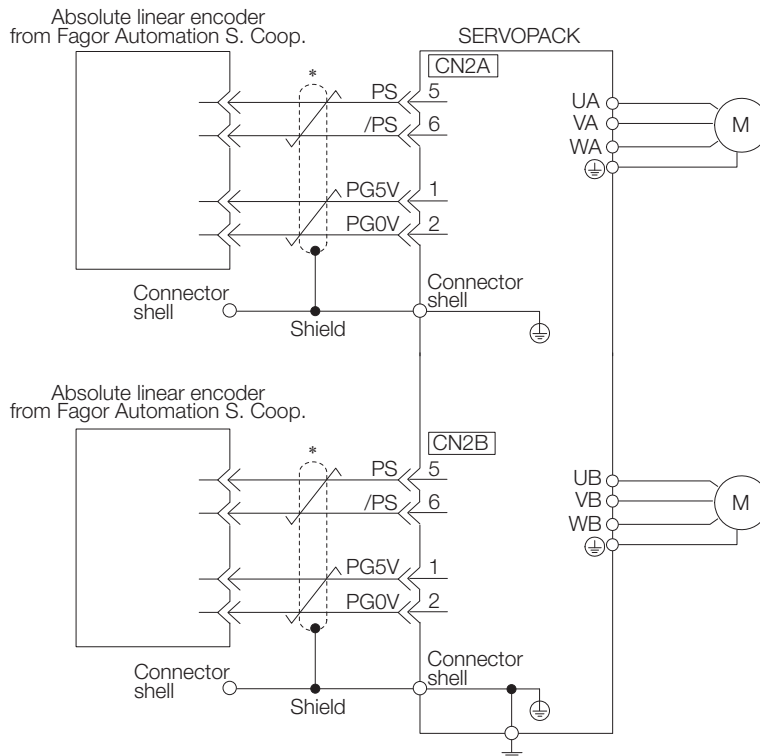

\* represents a shielded twisted-pair cable.

◆ Connections to Absolute Linear Encoder from Canon Precision Inc.

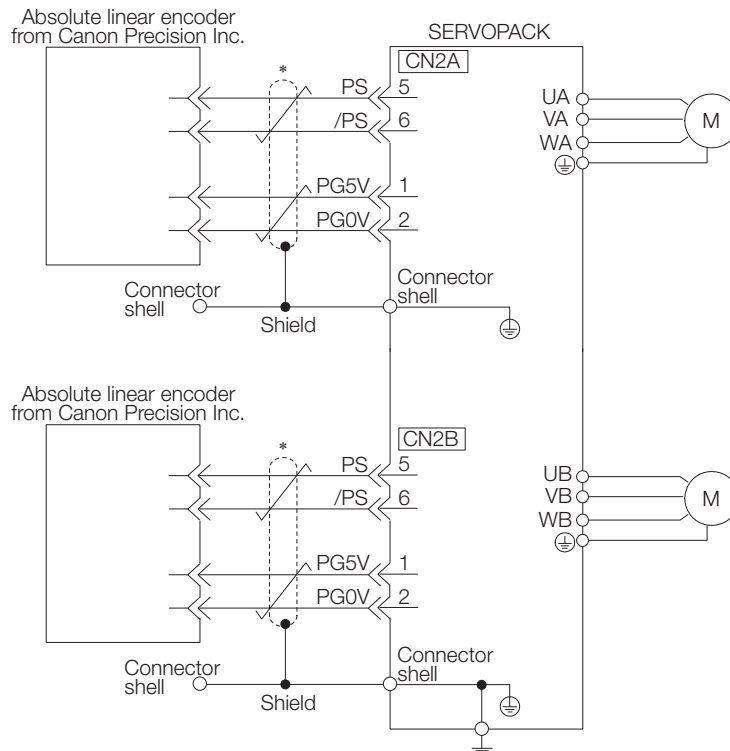

\* represents a shielded twisted-pair cable.

## When Using an Incremental Linear Encoder

The wiring depends on the manufacturer of the linear encoder.

### ◆ Connections to Linear Encoder from Dr. JOHANNES HEIDENHAIN GmbH

Linear encoder from  
Dr. JOHANNES  
HEIDENHAIN GmbH

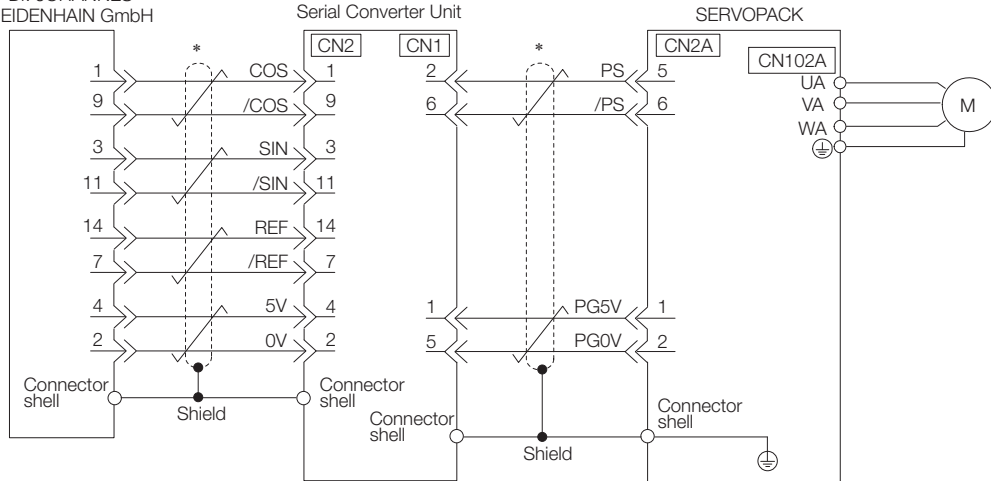

Linear encoder from  
Dr. JOHANNES  
HEIDENHAIN GmbH

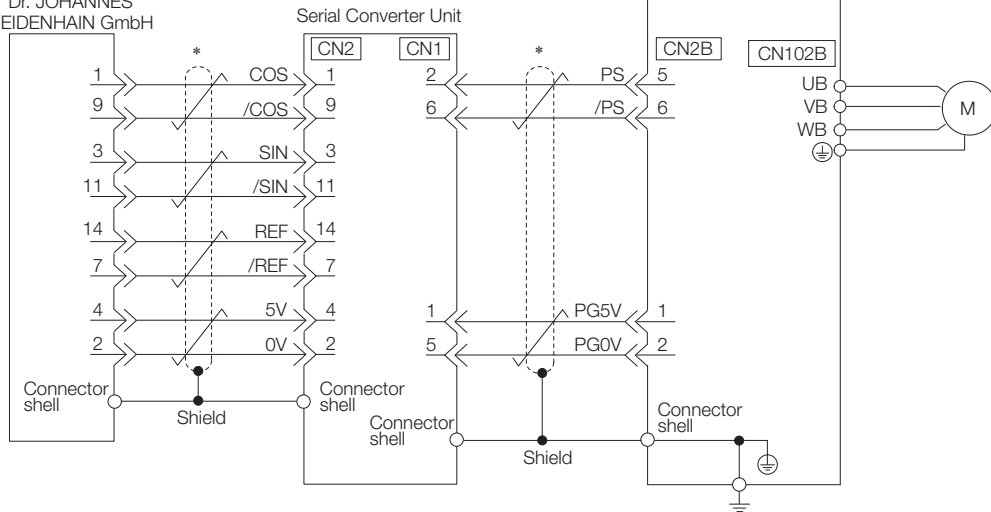

\* represents a shielded twisted-pair cable.



◆ Connections to Linear Encoder from Renishaw PLC

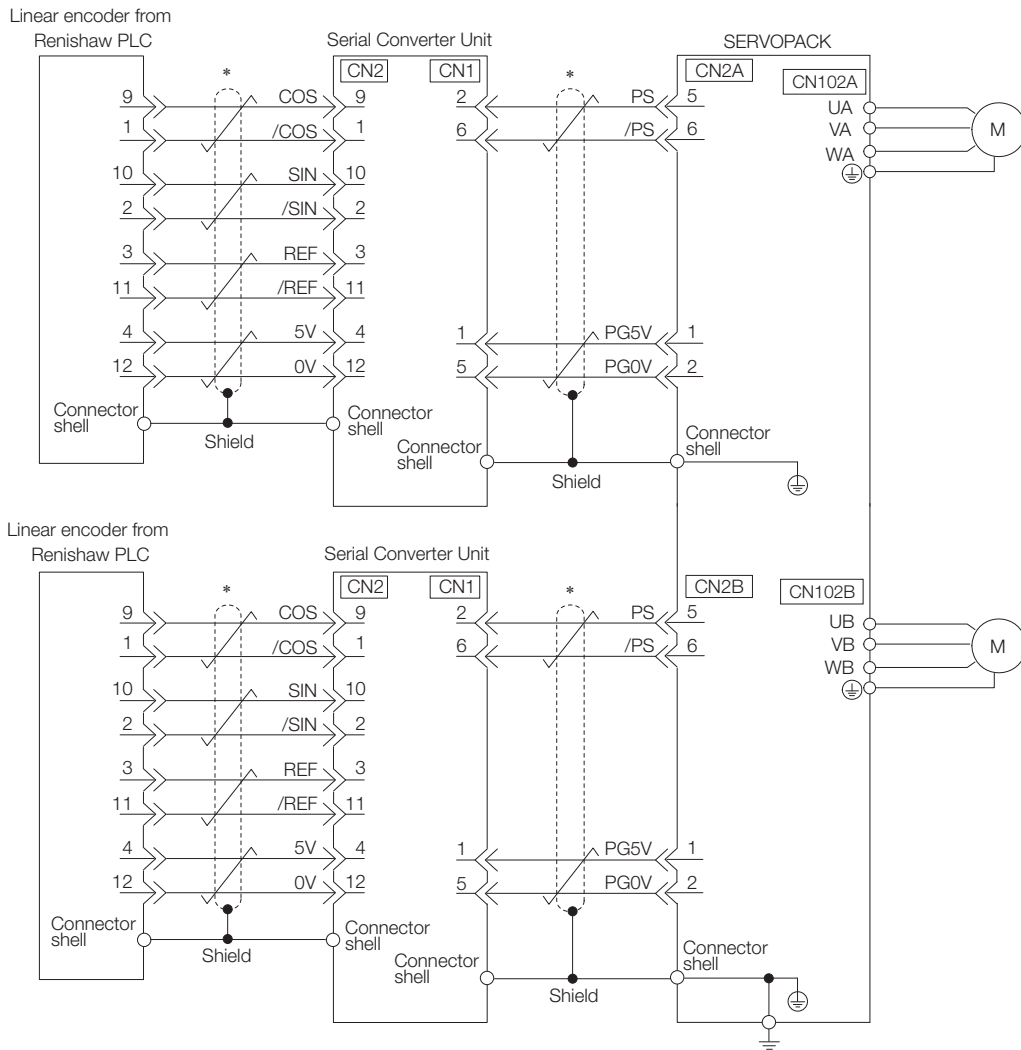



\*  represents a shielded twisted-pair cable.

◆ Connections to Linear Encoder from Magnescale Co., Ltd.

If you use a linear encoder from Magnescale Co., Ltd., the wiring will depend on the model of the linear encoder.

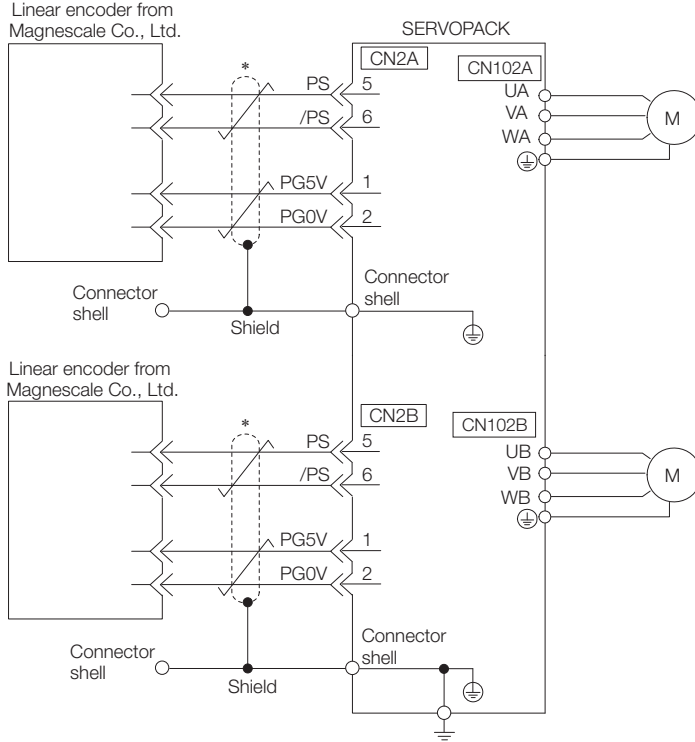
■ SR75 and SR85



\*  represents a shielded twisted-pair cable.

■ SL700, SL710, SL720, SL730, and SQ10

- PL101-RY, MQ10-FLA, or MQ10-GLA Interpolator

The following table gives the linear encoder and Interpolator combinations.

| Linear Encoder Model           | Interpolator Model |
|--------------------------------|--------------------|
| SL700, SL710, SL720, and SL730 | PL101-RY*1         |
| SQ10                           | MQ10-FLA*2         |
|                                | MQ10-GLA*2         |

\*1. This is the model of the Head with Interpolator.

\*2. This is the model of the Interpolator.

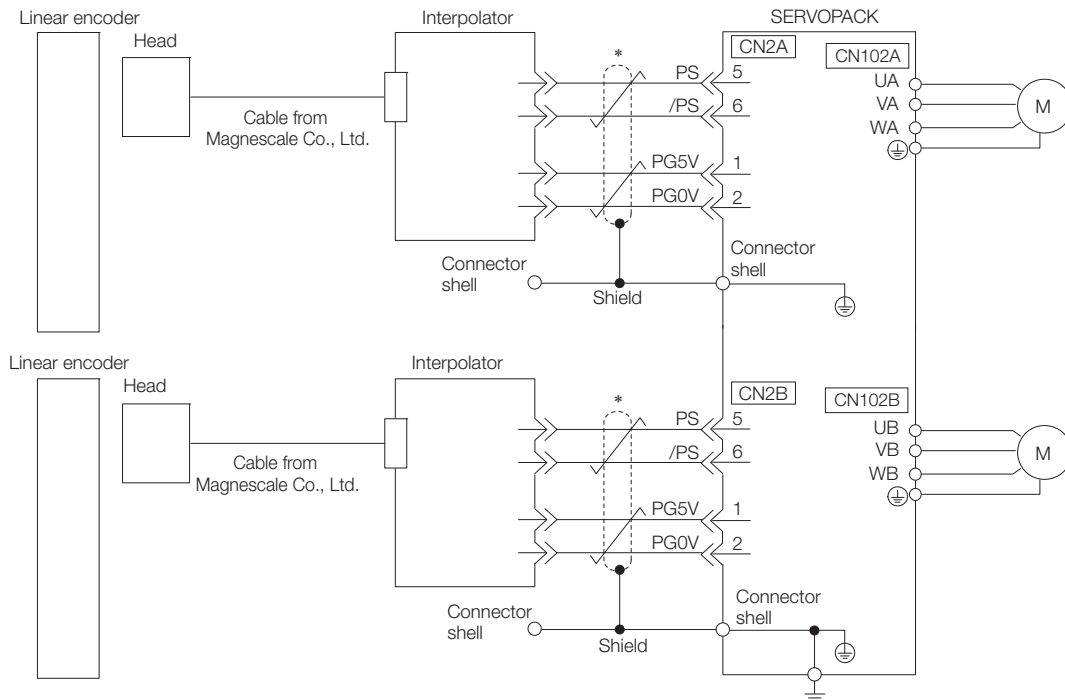



\*  represents a shielded twisted-pair cable.

4.4 Wiring Servomotors

4.4.3 Wiring the SERVOPACK to the Encoder

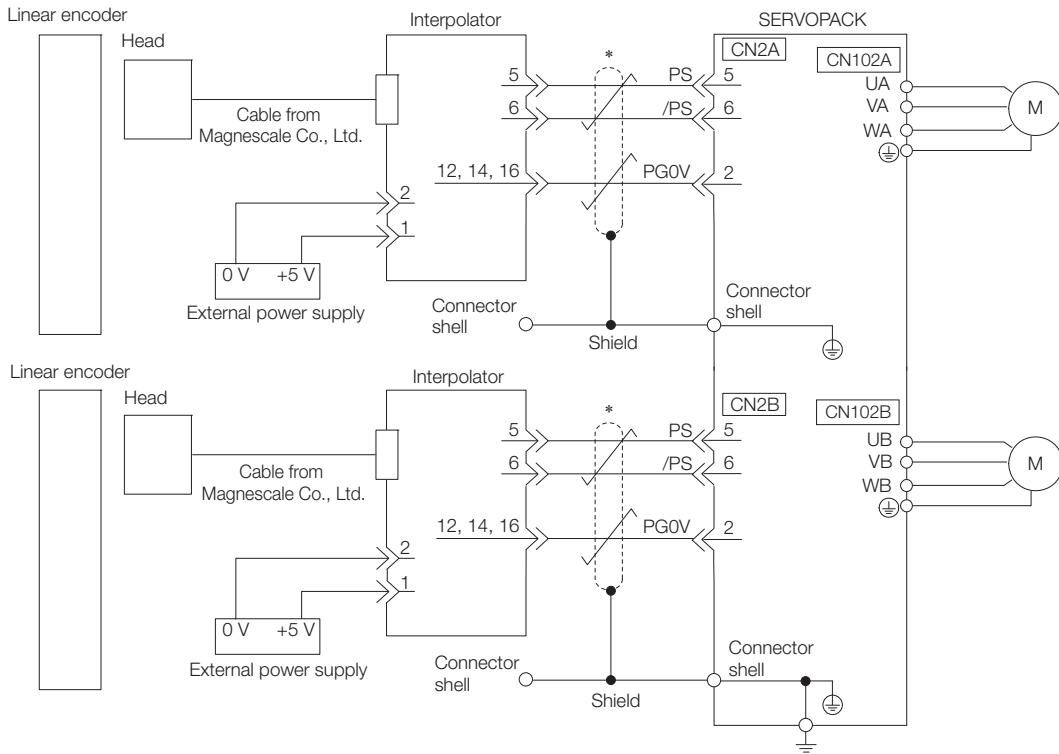
- SL700, SL710, SL720, and SL730
- MJ620-T13 Interpolator



\*  represents a shielded twisted-pair cable.

◆ Connections to Linear Encoder from Canon Precision Inc.

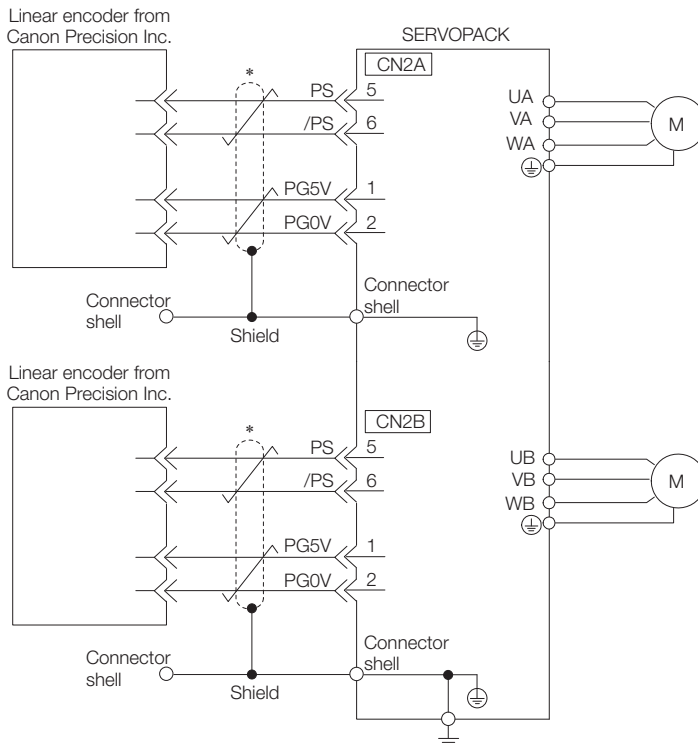

\*  represents a shielded twisted-pair cable.

## 4.4.4 Wiring the SERVOPACK to the Holding Brake



Important

- If you use a Rotary Servomotor, select a Surge Absorber according to the brake current and brake power supply. Refer to the catalog for details. A Surge Absorber is not required for axis A if a SERVOPACK with built-in Servomotor brake control is used with a Servomotor with a Brake.
- After the Surge Absorber is connected, check the time required to brake in your application. The Surge Absorber may affect the time required to brake. Configure the relay circuit to activate the holding brake for an emergency stop.

Relay Circuit Example

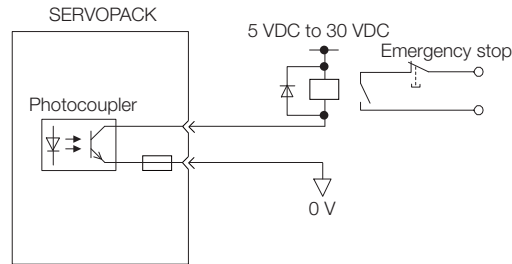

- You can change the output signal allocation of the /BK signal. Refer to the following section for details.
  - 🔗 **Allocating the /BK (Brake) Signal** on page 6-32
- If you use a 24-V brake, install a separate power supply for the 24-VDC power supply from other power supplies, such as the one for the I/O signals of the CN1 connector. If the power supply is shared, the I/O signals may malfunction.

## SERVOPACKs without Built-in Servomotor Brake Control

A wiring example for SERVOPACKs without built-in Servomotor brake control is provided below.

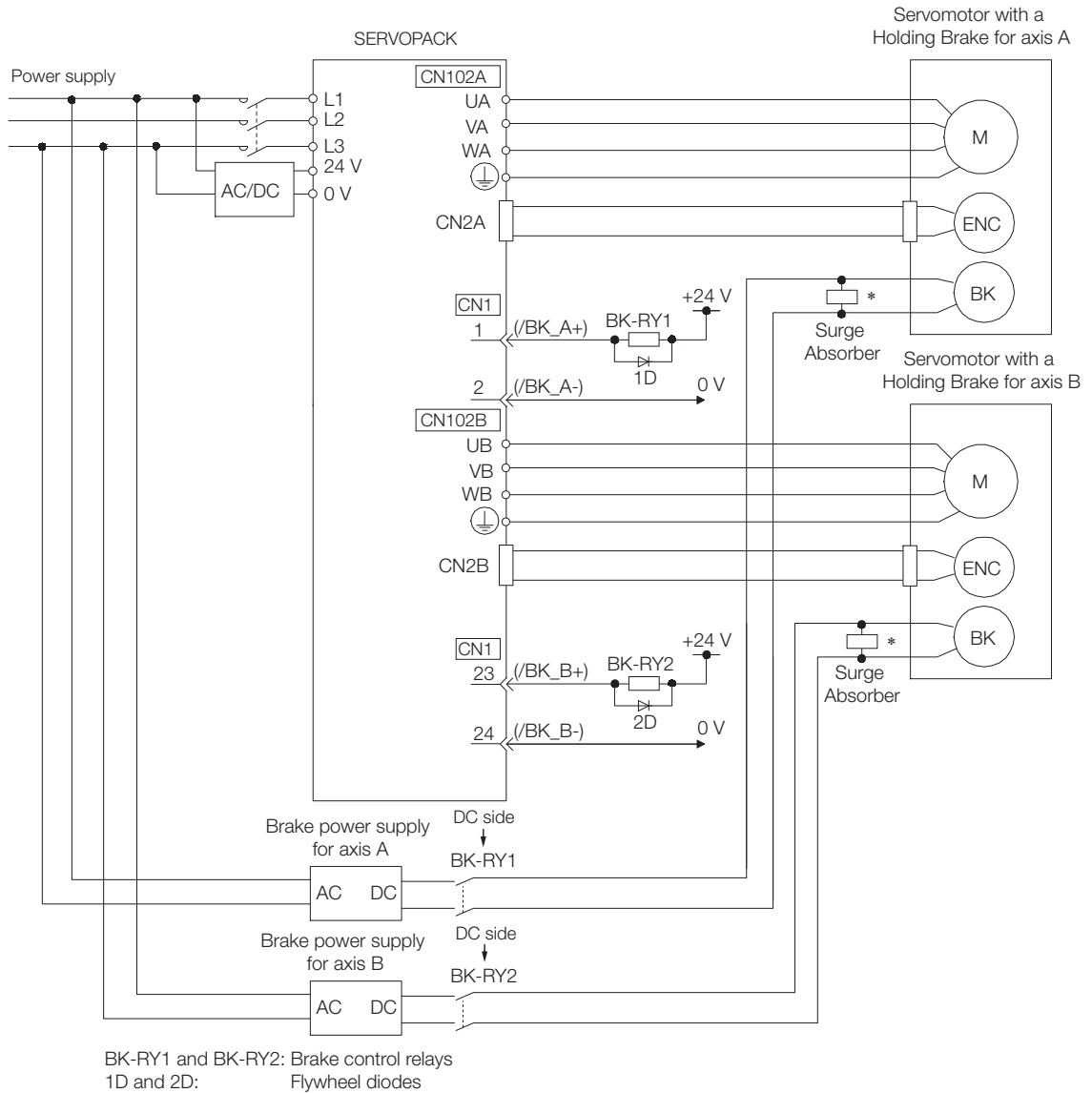

\* Install the Surge Absorber near the brake terminals on the Servomotor.

## SERVOPACKs with Built-in Servomotor Brake Control

SERVOPACKs with built-in brake control contain a brake relay.

The wiring is different because of the built-in brake relay. The following figure shows a wiring example.

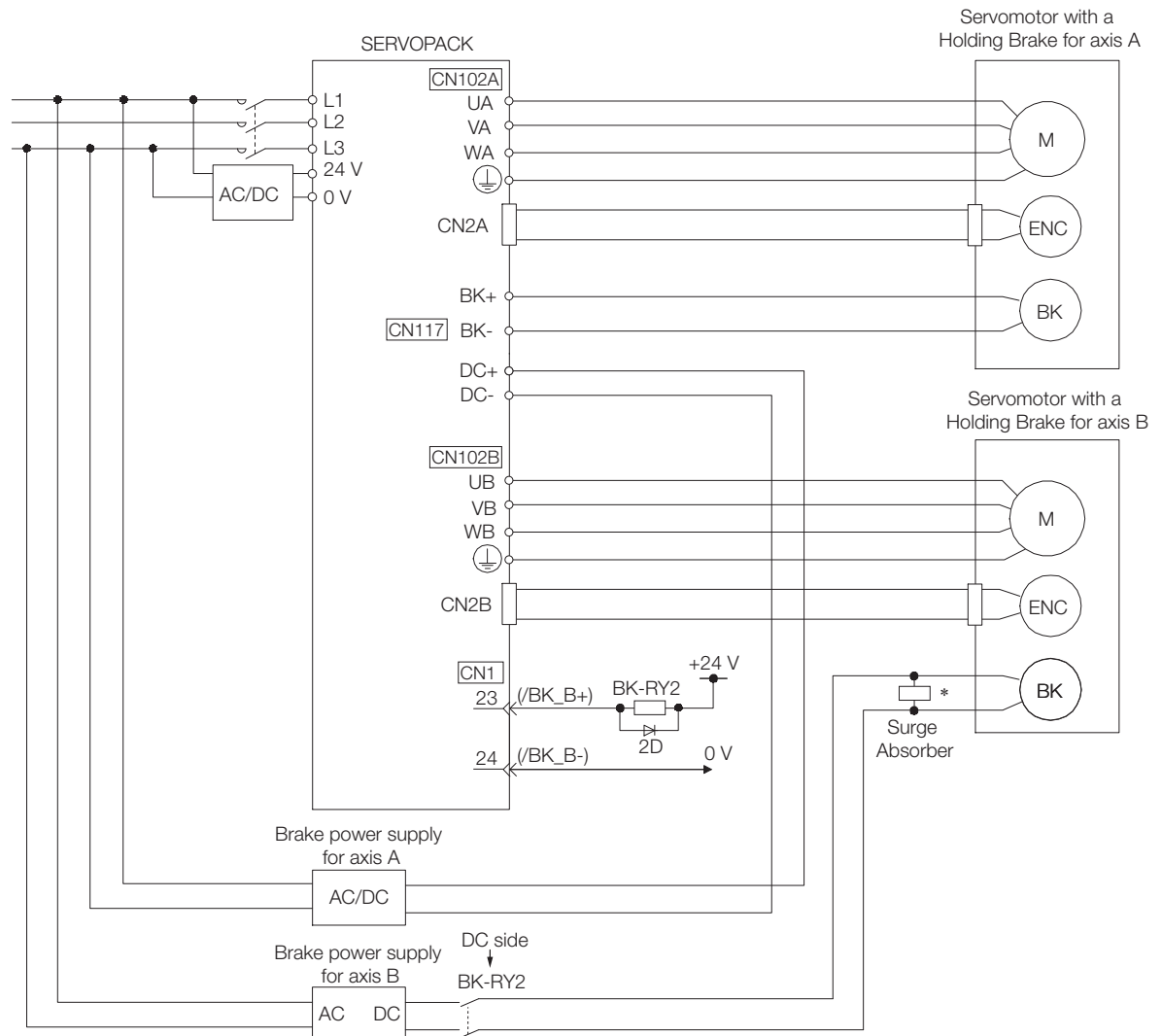

\* Install the Surge Absorber near the brake terminals on the Servomotor.

### • Connector Specifications

| Connector No. | Model                           | Number of Pins | Manufacturer                       |
|---------------|---------------------------------|----------------|------------------------------------|
| CN117         | BLF 5.08HC/04/180LR SN BK BX SO | 4              | Weidmüller Interface GmbH & Co. KG |

### ◆ Built-in Brake Relay Specifications

The specifications of the built-in brake relay are as follows:

- Service life (number of operations): 30,000 operations
- Allowable number of operations: 30 operations per minute max.

## 4.5 Connecting I/O Signals

### 4.5.1 I/O Signal Connector (CN1) Names and Functions

The following table gives the pin numbers, names, and functions the I/O signal pins for the default settings.

#### Input Signals

Default settings are given in parentheses.

| Signal                | Pin No. | Name   | Function  | Reference |
|-----------------------|---------|--|---|-----------|
| /SI01*<br>(P-OT_A)    | 7       | General-purpose<br>Sequence Inputs 1 and 11<br>(Forward Drive Prohibit<br>Input) | You can allocate the input signals<br>to use with parameters.<br>(Stops Servomotor drive (to prevent<br>overtravel) when the moving part of<br>the machine exceeds the range of<br>movement.)<br>• For axis A: /SI01 and /SI11<br>• For axis B: /SI02 and /SI12 | page 6-25 |
| /SI11*<br>(P-OT_B)    | 12      |  |   |           |
| /SI02*<br>(N-OT_A)    | 8       | General-purpose<br>Sequence Inputs 2 and 12<br>(Reverse Drive Prohibit<br>Input) |   |           |
| /SI12*<br>(N-OT_B)    | 13      |  |   |           |
| /SI03*<br>(/Probe1_A) | 9       | General-purpose<br>Sequence Inputs 3 and 13<br>(Probe 1 Latch Input)             | You can allocate the input signals<br>to use with parameters.<br>(Connect the external signals that<br>latch the current feedback pulse<br>counter.)<br>• For axis A: /SI03 and /SI04<br>• For axis B: /SI13 and /SI14  | -         |
| /SI13*<br>(/Probe1_B) | 18      |  |   |           |
| /SI04*<br>(/Probe2_A) | 10      | General-purpose<br>Sequence Inputs 4 and 14<br>(Probe 2 Latch Input 1)           | You can allocate the input signals<br>to use with parameters.<br>(Connect the switch that starts an<br>origin return.)<br>• For axis A: /SI05<br>• For axis B: /SI15  | -         |
| /SI14*<br>(/Probe2_B) | 19      |  |   |           |
| /SI05*<br>(/Home_A)   | 11      | General-purpose<br>Sequence Inputs 5 and 15<br>(Home Switch Input 2)             |   |           |
| /SI15*<br>(/Home_B)   | 20      |  |   |           |
| +24VIN                | 6       | Sequence Input Signal<br>Power Supply Input                                      | Inputs the sequence input signal<br>power supply.<br>Allowable voltage range: 24 VDC<br>±20%<br>The 24-VDC power supply is not<br>provided by Yaskawa.  | -         |
| BAT_A+                | 14      | Battery for Absolute<br>Encoder (+)  | Connecting pin for the absolute<br>encoder backup battery.<br>Do not connect these pins if you<br>use the Encoder Cable with a Bat-<br>tery Case.<br>• For axis A: BAT_A+ and BAT_A-<br>• For axis B: BAT_B+ and BAT_B-   | -         |
| BAT_B+                | 21      |  |   |           |
| BAT_A-                | 15      | Battery for Absolute<br>Encoder (-)  |   |           |
| BAT_B-                | 22      |  |   |           |
| TH_A                  | 5       | Overheat Protection Signal   | Inputs the overheat protection sig-<br>nal from a Linear Servomotor or<br>from a sensor attached to the<br>machine.<br>• For axis A: TH_A<br>• For axis B: TH_B   | -         |
| TH_B                  | 17      |  |   |           |

\* You can change the allocations. Refer to the following section for details.

 7.1.1 Input Signal Allocations on page 7-4

Note: If forward drive prohibition or reverse drive prohibition is used, the SERVOPACK is stopped by software controls. If the application does not satisfy the safety requirements, add external safety circuits as required.



## Output Signals

Default settings are given in parentheses.

| Signal             | Pin No. | Name   | Function  | Reference |
|--------------------|---------|--|---|-----------|
| ALM+               | 3       | Servo Alarm Output                                     | Turns OFF (opens) when an error is detected.  | page 7-10 |
| ALM-               | 4       |  |   |           |
| /SO1+*<br>(/BK_A+) | 1       | General-purpose<br>Sequence Output 1<br>(Brake Output) | You can allocate the output signals to use<br>with parameters.<br>(Controls the brake. The brake is released<br>when the signal turns ON (closes).)<br>• For axis A: /BK_A+ and /BK_A-<br>• For axis B: /BK_B+ and /BK_B- | page 6-31 |
| /SO1-*<br>(/BK_A-) | 2       |  |   |           |
| /SO2+*<br>(/BK_B+) | 23      | General-purpose<br>Sequence Output 2<br>(Brake Output) |   |           |
| /SO2-*<br>(/BK_B-) | 24      |  |   |           |
| /SO3+*             | 25      | General-purpose<br>Sequence Output 3                   | Used for general-purpose outputs.<br>Set the parameters to allocate functions.  | -         |
| /SO3-*             | 26      |  |   |           |
| /SO4+*             | 27      | General-purpose<br>Sequence Output 4                   |   |           |
| /SO4-*             | 28      |  |   |           |
| /SO5+*             | 29      | General-purpose<br>Sequence Output 5                   |   |           |
| /SO5-*             | 30      |  |   |           |
| SG                 | 16      | Signal ground  | This is the 0-V signal for the control circuits.  | -         |

\* You can change the allocations. Refer to the following section for details.

 7.1.2 Output Signal Allocations on page 7-7

## 4.5.2 I/O Signal Connector (CN1) Pin Arrangement

The following figure gives the pin arrangement of the of the I/O signal connector (CN1) for the default settings.

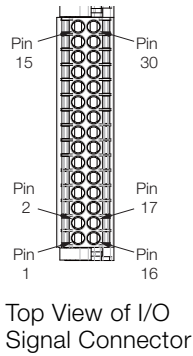

| No | Signal           | Specification                               | No | Signal            | Specification                               |
|----|------------------|---|----|-------------------|---|
| 15 | BAT_A-           | Battery for Absolute Encoder (-) for Axis A | 30 | /SO5-             | General-purpose Sequence Output 5           |
| 14 | BAT_A+           | Battery for Absolute Encoder (+) for Axis A | 29 | /SO5+             | General-purpose Sequence Output 5           |
| 13 | /SI12 (N-OT_B)   | General-purpose Sequence Input 12           | 28 | /SO4-             | General-purpose Sequence Output 4           |
| 12 | /SI11 (P-OT_B)   | General-purpose Sequence Input 11           | 27 | /SO4+             | General-purpose Sequence Output 4           |
| 11 | /SI5 (/Home_A)   | General-purpose Sequence Input 5            | 26 | /SO3-             | General-purpose Sequence Output 3           |
| 10 | /SI4 (/Probe2_A) | General-purpose Sequence Input 4            | 25 | /SO3+             | General-purpose Sequence Output 3           |
| 9  | /SI3 (/Probe1_A) | General-purpose Sequence Input 3            | 24 | /SO2- (/BK_B-)    | General-purpose Sequence Output 2           |
| 8  | /SI2 (N-OT_A)    | General-purpose Sequence Input 2            | 23 | /SO2+ (/BK_B+)    | General-purpose Sequence Output 2           |
| 7  | /SI1 (P-OT_A)    | General-purpose Sequence Input 1            | 22 | BAT_B-            | Battery for Absolute Encoder (-) for Axis B |
| 6  | +24VIN           | Sequence input signal power supply input    | 21 | BAT_B+            | Battery for Absolute Encoder (+) for Axis B |
| 5  | TH_A             | Overheat Protection Input for Axis A        | 20 | /SI15 (/Home_B)   | General-purpose Sequence Input 15           |
| 4  | ALM-             | Servo Alarm Output                          | 19 | /SI14 (/Probe2_B) | General-purpose Sequence Input 14           |
| 3  | ALM+             | Servo Alarm Output                          | 18 | /SI13 (/Probe1_B) | General-purpose Sequence Input 13           |
| 2  | /SO1- (/BK_A-)   | General-purpose Sequence Output 1           | 17 | TH_B              | Overheat Protection Input for Axis B        |
| 1  | /SO1+ (/BK_A+)   | General-purpose Sequence Output 1           | 16 | SG                | Signal ground                               |

## 4.5.3 I/O Signal Wiring Examples

### Using a Rotary Servomotor

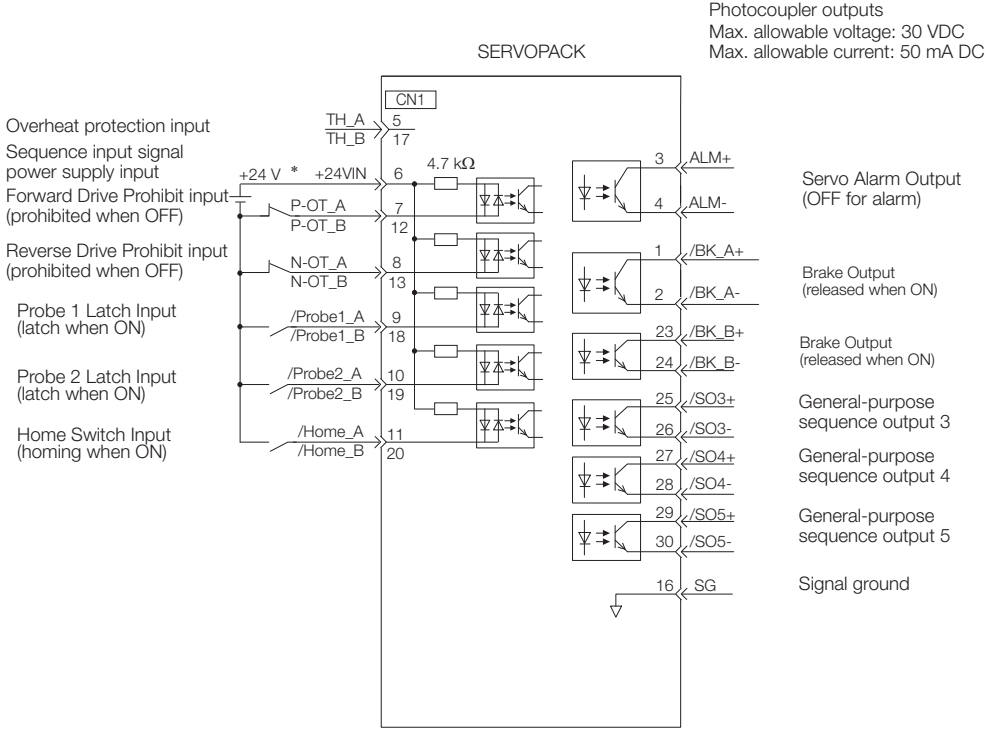

\* The 24-VDC power supply is not provided by Yaskawa. Use a 24-VDC power supply with double insulation or reinforced insulation.

Note: 1. You can use parameter settings to change some of the I/O signal allocations. Refer to the following section for details.

7.1 I/O Signal Allocations on page 7-3

2. If you use a 24-V brake, install a separate power supply for the 24-VDC power supply from other power supplies, such as the one for the I/O signals of the CN1 connector. If the power supply is shared, the I/O signals may malfunction.

## Using a Linear Servomotor

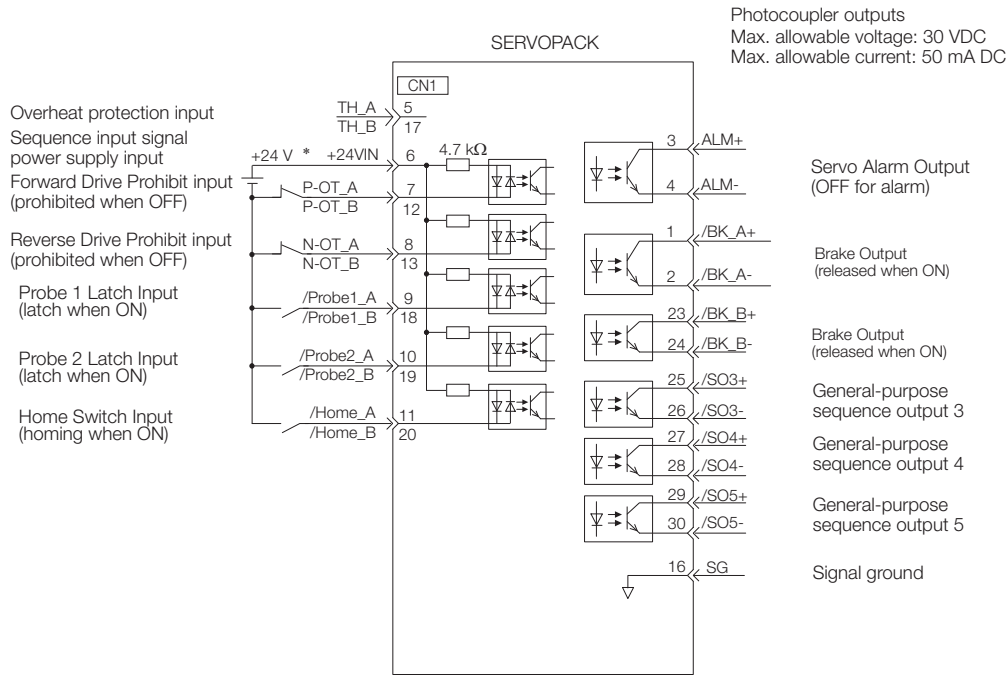

\* The 24-VDC power supply is not provided by Yaskawa. Use a 24-VDC power supply with double insulation or reinforced insulation.

Note: 1. You can use parameter settings to change some of the I/O signal allocations. Refer to the following section for details.

 **7.1 I/O Signal Allocations** on page 7-3

2. If you use a 24-V brake, install a separate power supply for the 24-VDC power supply from other power supplies, such as the one for the I/O signals of the CN1 connector. If the power supply is shared, the I/O signals may malfunction.

## 4.5.4 I/O Circuits

### Sequence Input Circuits

#### ◆ Photocoupler Input Circuits

This section describes CN1 connector terminals 7 to 13 and 18 to 20.

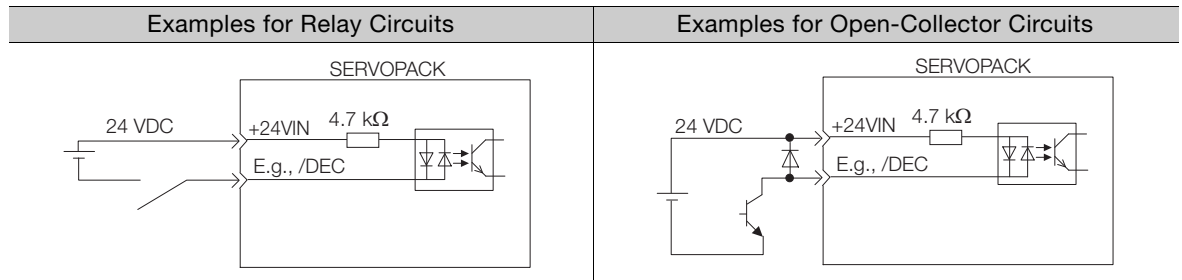

Note: The 24-VDC external power supply capacity must be 100 mA minimum.

The SERVOPACK input circuits use bidirectional photocouplers. Select either a sink circuit or source circuit according to the specifications required by the machine.

Note: The connection examples in 4.5.3 I/O Signal Wiring Examples on page 4-39 are for sink circuit connections.

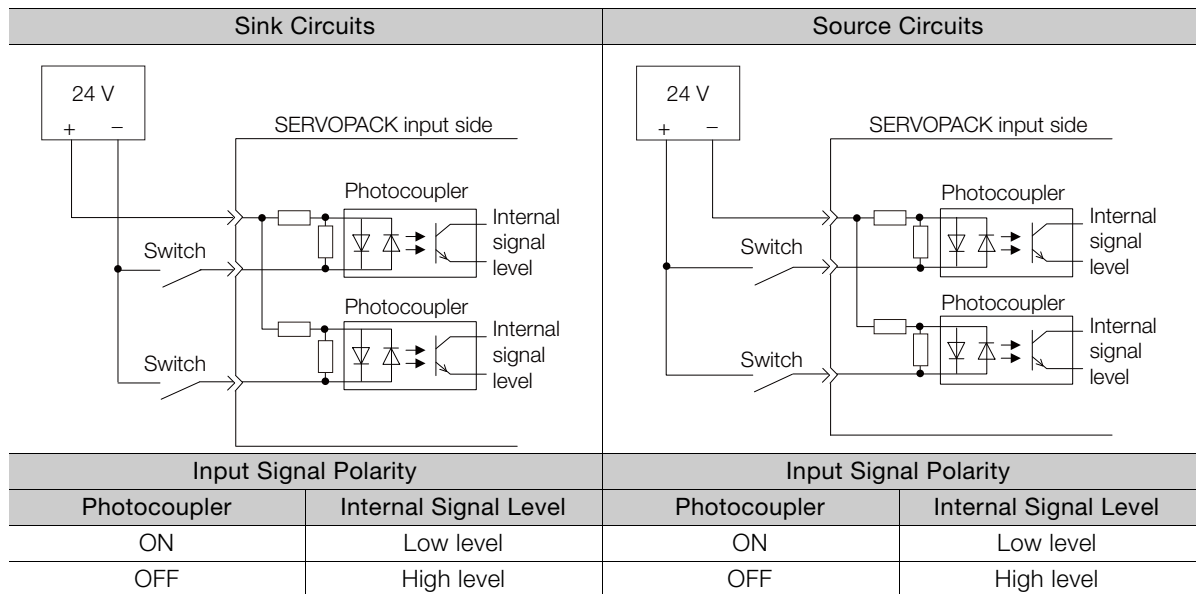

## Sequence Output Circuits



Important

Incorrect wiring or incorrect voltage application to the output circuits may cause short-circuit failures.

If a short-circuit failure occurs as a result of any of these causes, the holding brake will not work. This could damage the machine or cause an accident that may result in death or injury.

### ◆ Photocoupler Output Circuits

Photocoupler output circuits are used for the ALM (Servo Alarm), /S-RDY (Servo Ready), and other sequence output signals. Connect an open-collector output circuit to a photocoupler, relay, or line-receiver circuit.

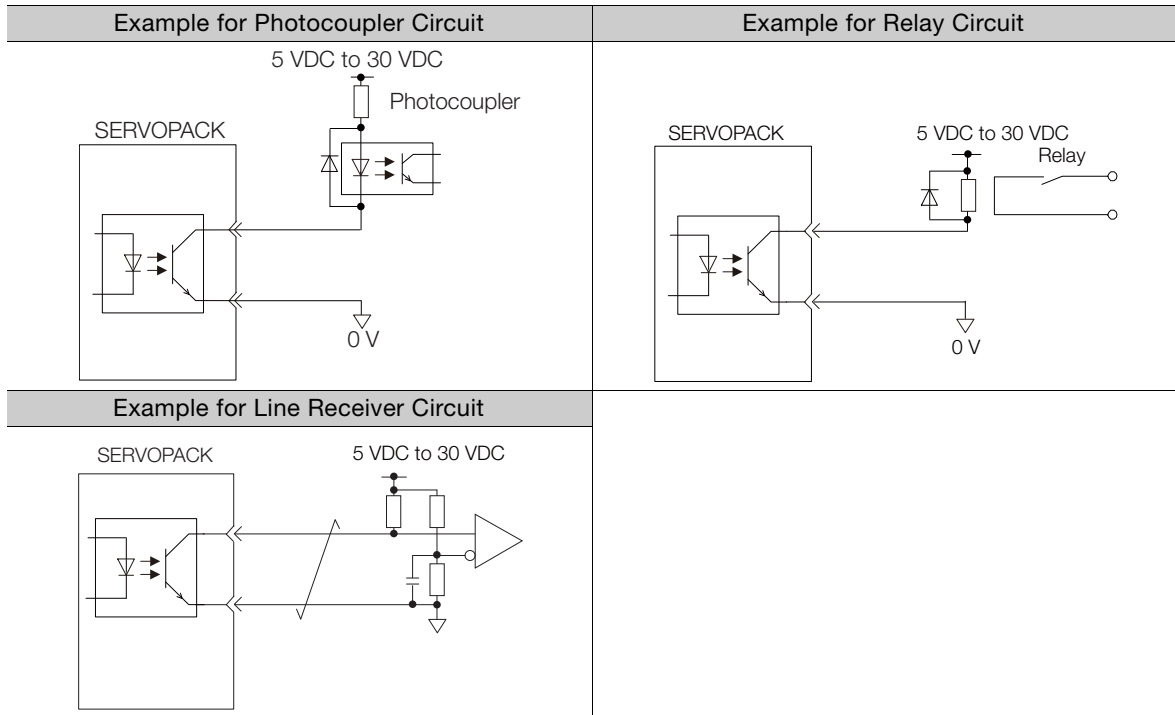

Note: The maximum allowable voltage and current range for photocoupler output circuits are as follows:

- Maximum allowable voltage: 30 VDC
- Current range: 5 mA to 50 mA DC

## 4.6

## Connecting Safety Function Signals

This section describes the wiring required to use a safety function.

Refer to the following chapter for details on the safety function.

 Chapter 11 Safety Functions

## 4.6.1 Pin Arrangement of Safety Function Signals (CN8A/CN8B)

### CN8A Pin Layout

| Pin No. | Signal    | Name   | Function   |
|---------|-----------|--|--|
| 1       | –         | - (Do not use these pins because they are connected to internal circuits.) |  |
| 2       | –         |  |  |
| 3       | /HWBB_A1- | Hard Wire Base Block Input 1 for Axis A                                    | For a hard wire base block input. The base block (motor power turned OFF) is in effect when the signal is OFF. |
| 4       | /HWBB_A1+ |  |  |
| 5       | /HWBB_A2- | Hard Wire Base Block Input 2 for Axis A                                    |  |
| 6       | /HWBB_A2+ |  |  |
| 7       | EDM_A-    | External Device Monitor Output for Axis A                                  | Turns ON when the /HWBB_A1 and the /HWBB_A2 signals are input and the SERVOPACK enters a base block state.     |
| 8       | EDM_A+    |  |  |

### CN8B Pin Layout

| Pin No. | Signal    | Name   | Function   |
|---------|-----------|--|--|
| 1       | –         | - (Do not use these pins because they are connected to internal circuits.) |  |
| 2       | –         |  |  |
| 3       | /HWBB_B1- | Hard Wire Base Block Input 1 for Axis B                                    | For a hard wire base block input. The base block (motor power turned OFF) is in effect when the signal is OFF. |
| 4       | /HWBB_B1+ |  |  |
| 5       | /HWBB_B2- | Hard Wire Base Block Input 2 for Axis B                                    |  |
| 6       | /HWBB_B2+ |  |  |
| 7       | EDM_B-    | External Device Monitor Output for Axis B                                  | Turns ON when the /HWBB_B1 and the /HWBB_B2 signals are input and the SERVOPACK enters a base block state.     |
| 8       | EDM_B+    |  |  |

## 4.6.2 I/O Circuits



Important

For safety function signal connections, the input signal is the 0-V common and the output signal is a source output. This is opposite to other signals described in this manual. To avoid confusion, the ON and OFF status of signals for the safety function are defined as follows:

- ON: The state in which the relay contacts are closed or the transistor is ON and current flows into the signal line.
- OFF: The state in which the relay contacts are open or the transistor is OFF and no current flows into the signal line.

### Safety Input Circuits

Use a 0-V common to connect the safety function signals. You must connect redundant input signals.

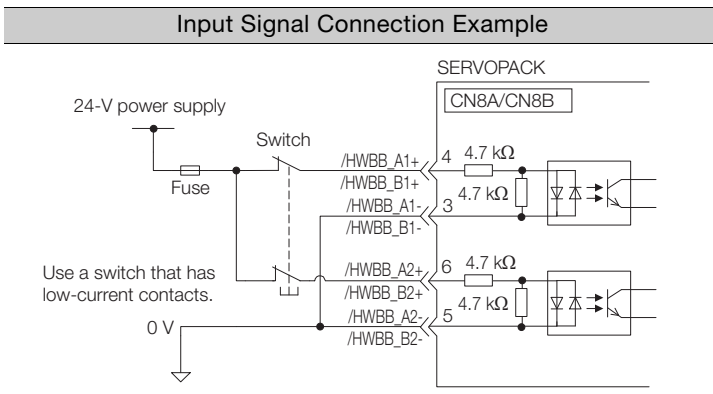

#### ◆ Input (HWBB) Signal Specifications

| Type   | Signal   | Connector Pin No. | Status      | Meaning   |
|--------|----------|-------------------|-------------|---|
| Inputs | /HWBB_A1 | CN8A-4<br>CN8A-3  | ON (closed) | Does not activate the HWBB for axis A (normal operation).       |
|        |          |                   | OFF (open)  | Activates the HWBB for axis A (motor current shut-OFF request). |
|        | /HWBB_A2 | CN8A-6<br>CN8A-5  | ON (closed) | Does not activate the HWBB for axis A (normal operation).       |
|        |          |                   | OFF (open)  | Activates the HWBB for axis A (motor current shut-OFF request). |
|        | /HWBB_B1 | CN8B-4<br>CN8B-3  | ON (closed) | Does not activate the HWBB for axis B (normal operation).       |
|        |          |                   | OFF (open)  | Activates the HWBB for axis B (motor current shut-OFF request). |
|        | /HWBB_B2 | CN8B-6<br>CN8B-5  | ON (closed) | Does not activate the HWBB for axis B (normal operation).       |
|        |          |                   | OFF (open)  | Activates the HWBB for axis B (motor current shut-OFF request). |



The input (HWBB) signals have the following electrical characteristics.

| Item                    | Characteristics | Remarks  |
|-------------------------|-----------------|--|
| Internal Impedance      | 4.7 k $\Omega$  | –  |
| Operating Voltage Range | +24 V $\pm$ 20% | –  |
| Maximum Delay Time      | 8 ms            | Time from /HWBB_A1 and /HWBB_A2 signals or /HWBB_B1 and /HWBB_B2 signals turning OFF until HWBB is activated |

## Diagnostic Output Circuits

The EDM\_A and EDM\_B output signals uses source circuits. The following figure shows a connection example.

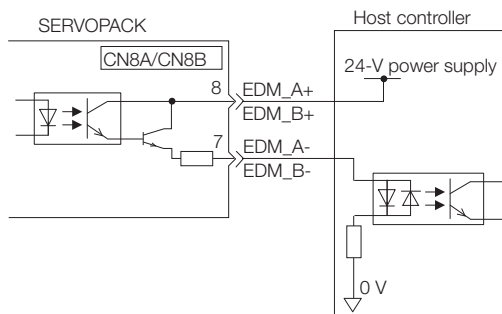

### ◆ EDM\_A and EDM\_B Output Signal Specifications

| Type   | Signal | Pin No.          | Output Status | Meaning  |
|--------|--------|------------------|---------------|--|
| Output | EDM_A  | CN8A-8<br>CN8A-7 | ON            | Both the /HWBB1 and /HWBB2 signals are operating normally.         |
|        |        |                  | OFF           | The /HWBB1 signal, the /HWBB2 signal, or both are not operating.   |
|        | EDM_B  | CN8B-8<br>CN8B-7 | ON            | Both the /HWBB11 and /HWBB12 signals are operating normally.       |
|        |        |                  | OFF           | The /HWBB11 signal, the /HWBB12 signal, or both are not operating. |

The electrical characteristics of the EDM\_A and EDM\_B output signals are as follows:

| Item                      | Characteristics | Remarks  |
|---------------------------|-----------------|--|
| Maximum Allowable Voltage | 30 VDC          | –  |
| Maximum Allowable Current | 50 mA DC        | –  |
| Maximum ON Voltage Drop   | 1.0 V           | Voltage between EDM_A+ and EDM_A- and between EDM_B+ and EDM_B- when current is 50 mA  |
| Maximum Delay Time        | 8 ms            | Time from a change in the /HWBB_A1 and /HWBB_A2 signals or /HWBB_B1 and /HWBB_B2 signals until a change in the EDM_A or EDM_B signal |

# 4.7 Connecting EtherCAT Communications Cables

Connect the EtherCAT Communications Cables to the CN6A and CN6B connectors.

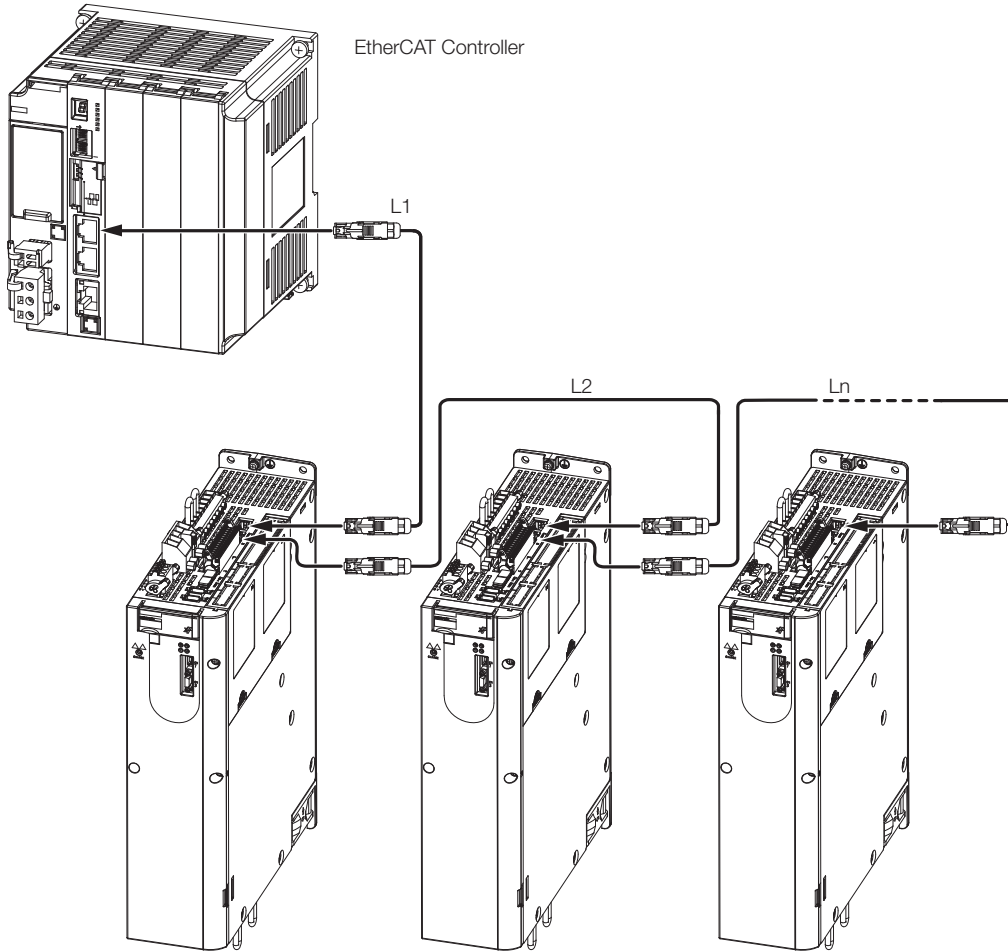

Note: The length of the cable between stations (L1, L2, ... Ln) must be 50 m or less.

## 4.7.1 EtherCAT Connectors (RJ45)

| Connector | Description                                     |
|-----------|---|
| CN6A      | ETHERCAT IN (EtherCAT signal input connector)   |
| CN6B      | ETHERCAT OUT (EtherCAT signal output connector) |

### ■ Connector Pin Assignments

| Pin | Signal | Remarks      |
|-----|--------|--------------|
| 1   | TD+    | Send data    |
| 2   | TD-    |              |
| 3   | RD+    | Receive data |
| 4   | -      | N.C.*        |
| 5   | -      | N.C.*        |
| 6   | RD-    | Receive data |
| 7   | -      | N.C.*        |
| 8   | -      | N.C.*        |

\* These pins are not connected to any signals.

---

## 4.7.2 Ethernet Communications Cables

---

Use category 5e Ethernet communications cables to make the connections.

Use cables with the following specifications.

Shielded: S/STP or S/UTP

Length: 50 m max. (between nodes)

The following cable is recommended.

| Manufacturer | Model  |
|--------------|--------|
| Beckhoff     | ZB9020 |

## 4.8 Connecting the Other Connectors

### 4.8.1 Serial Communications Connector (CN3)

To use a Digital Operator or to connect a computer with an RS-422 cable, connect CN3 on the SERVOPACK.

Refer to the following manual for the operating procedures for the Digital Operator.

📖  $\Sigma$ -7-Series Digital Operator Operating Manual (Manual No.: SIEP S800001 33)

### 4.8.2 Computer Connector (CN7)

To use the SigmaWin+ Engineering Tool, connect the computer on which the SigmaWin+ is installed to CN7 on the SERVOPACK.

Refer to the following manual for the operating procedures for the SigmaWin+.

📖 AC Servo Drive Engineering Tool SigmaWin+ Operation Manual (Manual No.: SIET S800001 34)



Use the Cable specified by Yaskawa for the Computer Cable. Operation will not be dependable with any other cable.

Refer to the catalog for details on the Computer Cable.

### 4.8.3 Analog Monitor Connector (CN5)

To use an analog monitor, connect CN5 on the SERVOPACK.

- Wiring Example

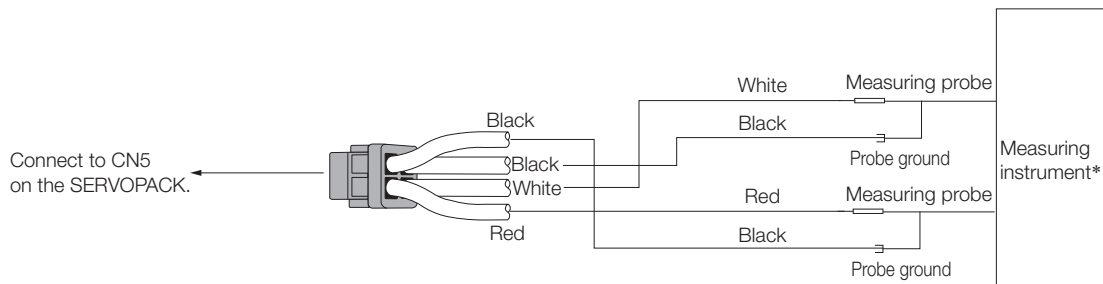

\* The measuring instrument is not provided by Yaskawa.

Refer to the following section for information on the monitoring methods for an analog monitor.

📖 10.3 Monitoring Machine Operation Status and Signal Waveforms on page 10-7

# Wiring and Settings for the Dynamic Brake

# 5

This chapter provides information on wiring and settings when using a dynamic brake with the SERVOPACK.

|            |  |             |
|------------|--|-------------|
| <b>5.1</b> | <b>Introduction to the Dynamic Brake . . . . .</b>                                       | <b>5-2</b>  |
| <b>5.2</b> | <b>Using the Dynamic Brake . . . . .</b>   | <b>5-3</b>  |
| 5.2.1      | Using the Dynamic Brake . . . . .  | 5-3         |
| 5.2.2      | Selecting the Dynamic Brake Resistor . . . . .   | 5-4         |
| 5.2.3      | Connecting Dynamic Brake Resistors . . . . .   | 5-7         |
| 5.2.4      | Setting the Energy Consumption and Resistance<br>of the Dynamic Brake Resistor . . . . . | 5-9         |
| <b>5.3</b> | <b>Coasting Distances for Dynamic Braking . . .</b>                                      | <b>5-10</b> |
| 5.3.1      | Coasting Distance during Dynamic Braking . . .   | 5-10        |
| 5.3.2      | Data for Calculating Coasting Distance . . . . .   | 5-11        |

# 5.1 Introduction to the Dynamic Brake

Dynamic braking is a method in which the kinetic energy of the Servomotor is converted to electrical energy, and then this energy is consumed as thermal energy with a resistor to brake the motor.

The smaller the resistance of the Dynamic Brake Resistor, the faster the Servomotor can be stopped and the shorter the coasting distance will be. However, the larger the resistance of the Dynamic Brake Resistor, the more time will be required to stop the Servomotor and the longer the coasting distance will be.

Refer to the following section for details on the coasting distance.

 5.3 Coasting Distances for Dynamic Braking on page 5-10



Term

**Coasting Distance**  
 During dynamic braking, the Servomotor rotates due to inertia until the electrical energy is consumed. The travel distance at this time is called the coasting distance.

Dynamic braking can be used when an alarm occurs, when the servo is turned OFF, during an emergency stop, and when overtravel occurs by setting Pn001 = n.□□□X (Motor Stopping Method for Servo OFF and Group 1 Alarms) to 0 or 1.

|                  | Parameter                   | Meaning  | When Enabled  | Classification |
|------------------|-----------------------------|--|---------------|----------------|
| Pn001<br>(2001h) | n.□□□0<br>(default setting) | Stop the motor by applying the dynamic brake.                                    | After restart | Setup          |
|                  | n.□□□1                      | Stop the motor by the applying dynamic brake and then release the dynamic brake. |               |                |
|                  | n.□□□2                      | Coast the motor to a stop without the dynamic brake.                             |               |                |

## 5.2 Using the Dynamic Brake

This section describes how to use the dynamic brake.

### 5.2.1 Using the Dynamic Brake

Set up the SERVOPACK according to the following flowchart.

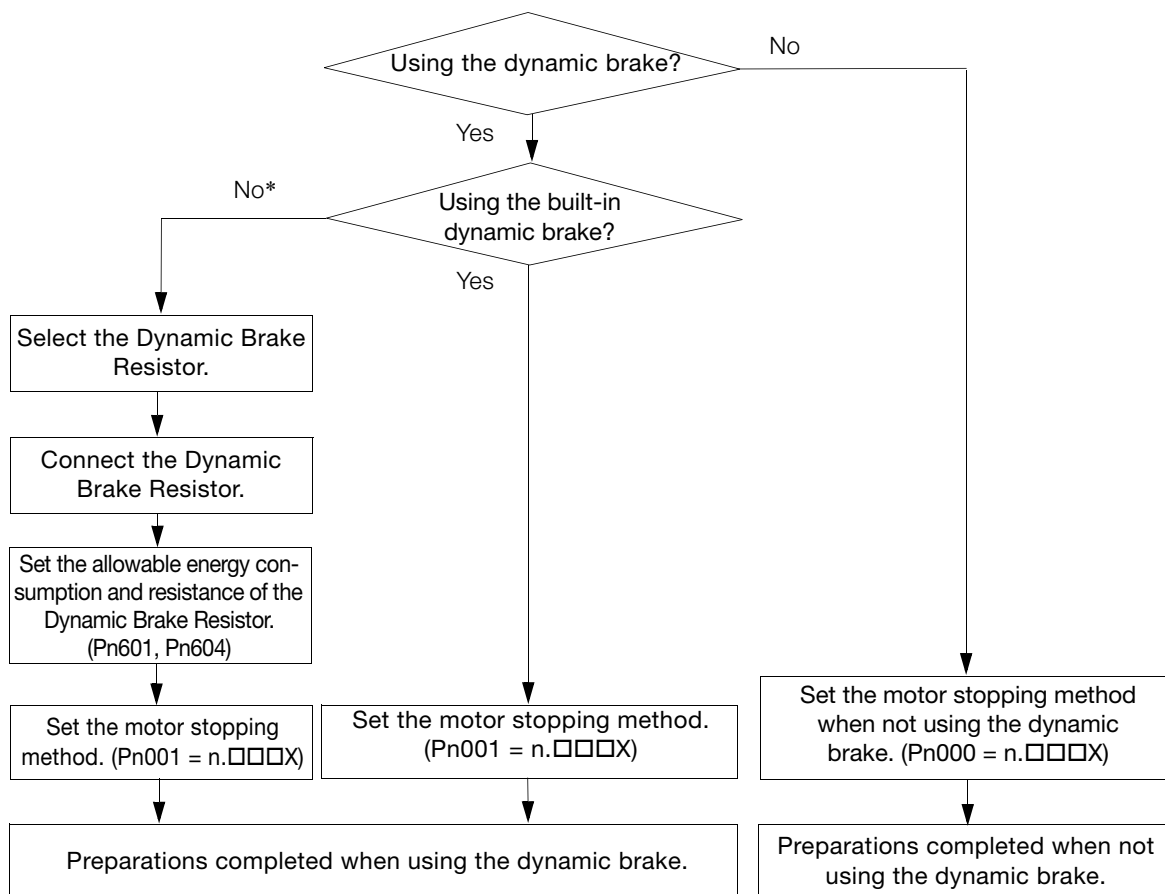

\* An External Dynamic Brake Resistor must be connected to the SERVOPACK to operate the SERVOPACK in the following manner.

- When specifying the brake torque when stopping with the dynamic brake.
- When operating with a load moment of inertia that exceeds the rating.

## Setting When Not Using Dynamic Braking



When not using dynamic braking, set Pn001 = n.□□□X (Motor Stopping Method for Servo OFF and Group 1 Alarms) to 2.

| Parameter        | Meaning                     | When Enabled   | Classification |       |
|------------------|-----------------------------|--|----------------|-------|
| Pn001<br>(2001h) | n.□□□0<br>(default setting) | Stop the motor by applying the dynamic brake.                                    | After restart  | Setup |
|                  | n.□□□1                      | Stop the motor by the applying dynamic brake and then release the dynamic brake. |                |       |
|                  | n.□□□2                      | Coast the motor to a stop without the dynamic brake.                             |                |       |

## Setting When Using Dynamic Braking

When using dynamic braking, set Pn001 = n.□□□X (Motor Stopping Method for Servo OFF and Group 1 Alarms) to 0 or 1.

You must complete the following items to use the dynamic brake.

- Selecting the Dynamic Brake Resistor  
 5.2.2 *Selecting the Dynamic Brake Resistor* on page 5-4
- Connecting the Dynamic Brake Resistor  
 5.2.3 *Connecting Dynamic Brake Resistors* on page 5-7
- Parameter Settings for the Dynamic Brake  
 5.2.4 *Setting the Energy Consumption and Resistance of the Dynamic Brake Resistor* on page 5-9

Note: When using the dynamic brake built into the SERVOPACK, you do not need to connect a Dynamic Brake Resistor.

## 5.2.2 Selecting the Dynamic Brake Resistor

This section describes the selection of the Dynamic Brake Resistor.

To select the Dynamic Brake Resistor, you must calculate the resistance and energy consumption for the specifications of the machine.

### WARNING

- Do not use dynamic braking for any application other than an emergency stop.  
There is a risk of failure due to rapid deterioration of elements in the SERVOPACK and the risk of unexpected operation, machine damage, burning, or injury.
- Use a Dynamic Brake Resistor matched to the specifications of the machine.  
There is a risk of unexpected operation, machine damage, burning, or injury.
- When using dynamic braking, implement suitable safety measures on the machine.  
There is a risk of unexpected operation, machine damage, burning, or injury.
- In situation where the motor will be rotated from the machine after it has been stopped, set the SERVOPACK to coast to stop instead of using dynamic braking.  
There is a risk of burning in the equipment, damage to the machine, or injury.

## Resistance

Based on the characteristic graphs of the Servomotor that will be used, you must determine the resistance that can satisfy the limit of instantaneous maximum brake torque.

### CAUTION

- Do not select a resistor with resistance less than the minimum allowable resistance.  
There is a risk of burning in the SERVOPACK or Servomotor, damage to the machine, or injury.



If it is not necessary to reduce the brake torque, select a Dynamic Brake Resistor with the following resistance.

| Model |       | Minimum Allowable Resistance ( $\pm 5\%$ ) |
|-------|-------|--|
| SGD7W | -2R6D | 30 $\Omega$                                |
|       | -5R4D | 20 $\Omega$                                |

If it is necessary to reduce the brake torque, determine the resistance based on the characteristic graphs.

The following graphs show the relationship between the instantaneous maximum brake torque of the Servomotor and the resistance of the dynamic brake.

◆ Rotary Servomotors

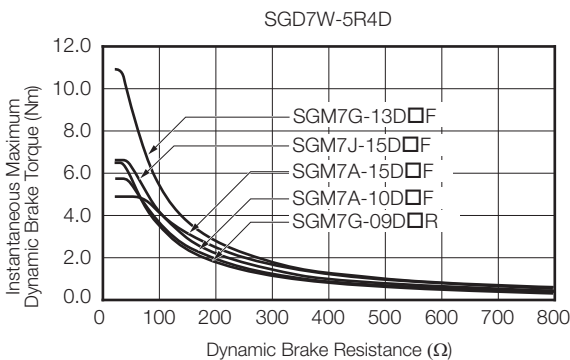
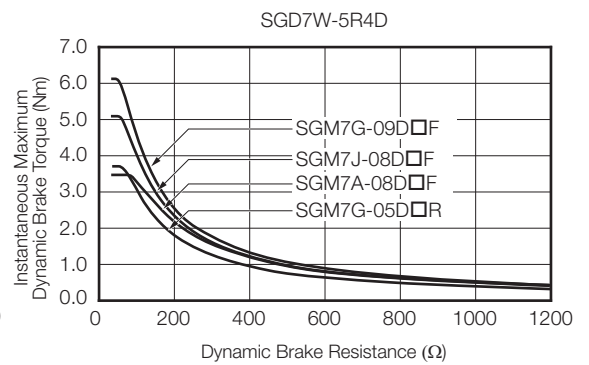
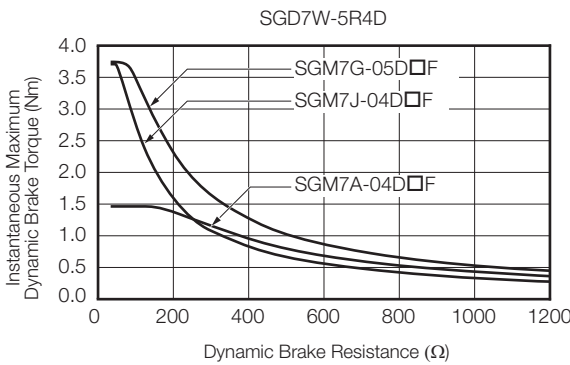
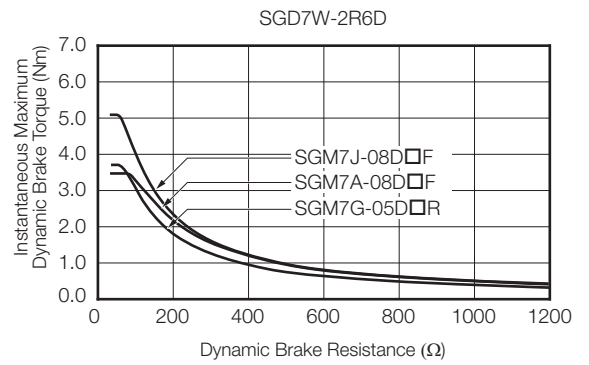
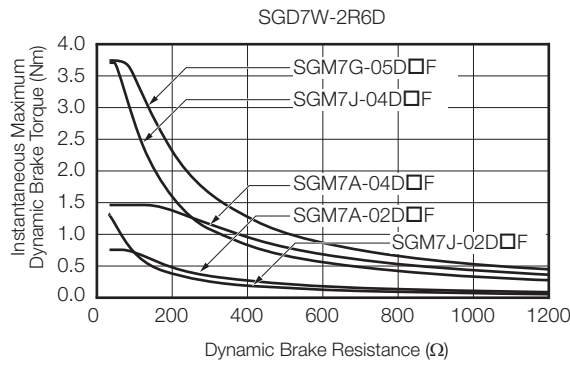

◆ Linear Servomotors

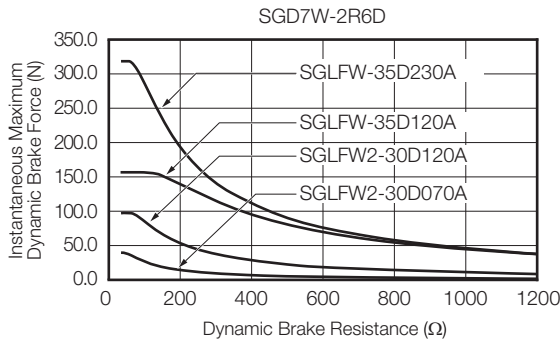

◆ Energy Consumption of the Dynamic Brake Resistor

Calculate the energy consumption required to stop the Servomotor using the Dynamic Brake Resistor.

To simplify the calculation of energy consumption, assume that all kinetic energy until the Servomotor stops is consumed by the Dynamic Brake Resistor and calculate energy consumption with the following formula.

Calculate energy consumption at the maximum value of kinetic energy of the Servomotor out of all anticipated operation patterns.

■ Rotary Servomotors

Energy consumption of Dynamic Brake Resistor:  $E_{DB}$  [J]

Motor moment of inertia:  $J_M$  [kg·m<sup>2</sup>]

Load moment of inertia:  $J_L$  [kg·m<sup>2</sup>]

Motor speed before dynamic braking:  $N$  [min<sup>-1</sup>]

$$E_{DB} = 1/2 \times (J_M + J_L) \times (2\pi N/60)^2$$

Note: Refer to the catalog or product manual of the Servomotor for details on the motor moment of inertia.

■ Linear Servomotors

Energy consumption of Dynamic Brake Resistor:  $E_{DB}$  [J]

Moving Coil mass:  $M_M$  [kg]

Load mass:  $M_L$  [kg]

Movement speed before dynamic braking:  $V$  [m/s]

$$E_{DB} = 1/2 \times (M_M + M_L) \times V^2$$

Note: Refer to the catalog or product manual of the Servomotor for details on the Moving Coil mass.

◆ Specifications of the Dynamic Brake Resistor

Have the following specifications ready when purchasing the Dynamic Brake Resistor. In the blank cells of the table, write down the specifications of the Dynamic Brake Resistor that you are considering for purchase, and confirm these specifications with the manufacturer of the Resistor.

| Item  | Specification  |
|---|--|
| Resistance (Ω)  |  |
| Energy consumption of resistor from dynamic braking (J)   |  |
| Number of operations of the dynamic brake<br>(Number of times the dynamic brake will be used in the service life of the machine (reference data)) |  |
| Wire size   | AWG14 (2.0 mm <sup>2</sup> ) to AWG18 (0.9 mm <sup>2</sup> ) |

## 5.2.3 Connecting Dynamic Brake Resistors

A connector or terminal block is used to wire a Dynamic Brake Resistor.

### Terminal Symbols and Terminal Names

#### CAUTION

- Wire all connections correctly according to the following table.  
There is a risk of SERVOPACK failure or fire if incorrect wiring is performed.

| SERVOPACK Model  | Terminal Symbols                           | Terminal Name                    | Specification  |
|------------------|--|----------------------------------|--|
| SGD7W-2R6D, 5R4D | Axis A: D1A and D2A<br>Axis B: D1B and D2B | Dynamic Brake Resistor terminals | These terminals are connected to an External Dynamic Brake Resistor. |

### Connecting a Dynamic Brake Resistor

#### WARNING

- Wire the Dynamic Brake Resistor correctly. Do not connect the following terminals directly to each other: D1 and D2.  
There is a risk of burning in the SERVOPACK or Servomotor, damage to the machine, or injury.

#### CAUTION

- Mount Dynamic Brake Resistors only on nonflammable materials. Do not mount them on or near any flammable material.  
There is a risk of fire.

• Required Items

| Required Item                      | Remarks   |
|------------------------------------|---|
| Phillips or flat-blade screwdriver | Commercially available screwdriver with a tip thickness of 0.6 mm and tip width of 3.5 mm |

1. Prepare the connector that is provided with the SERVOPACK.
2. Remove the lead wire from between D2 and D3.

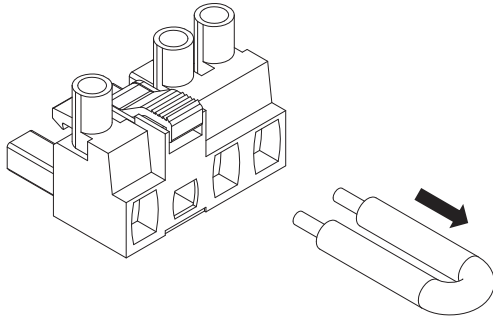

3. Remove the sheath from the wire to connect.

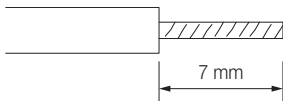

4. Open the wire insertion hole on the terminal connector with the screwdriver.
5. Insert the conductor of the wire into the wire insertion hole. After you insert the conductor, remove the screwdriver.

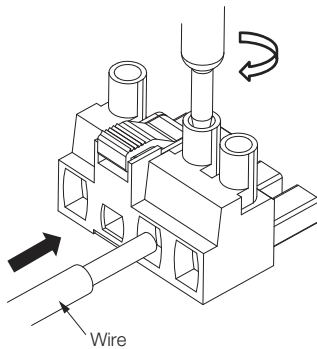

6. Connect Dynamic Brake Resistors to the D1A and D2A terminals and to the D1B and D2B terminals on the SERVOPACK.

Note: 1. The D1A, D2A, D1B, and D2B terminals are in the locations shown in the following figure. Do not connect anything to the D3 terminal.  
 2. Terminal labels (D1A, D2A, D1B, and D2B) are provided on the Dynamic Brake Resistor connector.

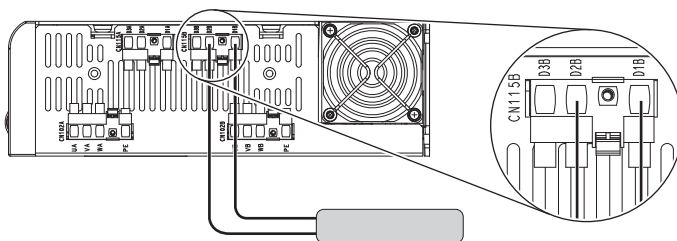

7. Set Pn601 (Dynamic Brake Resistor Allowable Energy Consumption) and Pn604 (Dynamic Brake Resistance).

Refer to the following section for details on the settings.

📖 5.2.4 Setting the Energy Consumption and Resistance of the Dynamic Brake Resistor on page 5-9

## 5.2.4 Setting the Energy Consumption and Resistance of the Dynamic Brake Resistor

If an External Dynamic Brake Resistor is connected, you must set Pn601 (Dynamic Brake Resistor Allowable Energy Consumption) and Pn604 (Dynamic Brake Resistance).

### WARNING

- If you connect an External Dynamic Brake Resistor, set Pn601 and Pn604 to suitable values. Failure to set these parameters will cause an A.730 alarm (Dynamic Brake Overload) to be detected incorrectly and can destroy the External Dynamic Brake Resistor, cause unintended operation during an emergency stop, cause damage to the machine, and cause burning or injury.
- When you select an External Dynamic Brake Resistor, make sure that it has a suitable energy consumption and resistance. There is a risk of personal injury or fire.

### CAUTION

- Mount Dynamic Brake Resistors only on nonflammable materials. Do not mount them on or near any flammable material. There is a risk of fire.

|                  |   |              |                 |               |                                    |                                       |                                     |
|------------------|---|--------------|-----------------|---------------|------------------------------------|---------------------------------------|-------------------------------------|
| Pn601<br>(2601h) | Dynamic Brake Resistor Allowable Energy Consumption |              |                 |               | <input type="text" value="Speed"/> | <input type="text" value="Position"/> | <input type="text" value="Torque"/> |
|                  | Setting Range                                       | Setting Unit | Default Setting | When Enabled  | Classification                     |                                       |                                     |
|                  | 0 to 65,535   | 10 J         | 0               | After restart | Setup                              |                                       |                                     |
| Pn604<br>(2604h) | Dynamic Brake Resistance                            |              |                 |               | <input type="text" value="Speed"/> | <input type="text" value="Position"/> | <input type="text" value="Torque"/> |
|                  | Setting Range                                       | Setting Unit | Default Setting | When Enabled  | Classification                     |                                       |                                     |
|                  | 0 to 65,535   | 10 mΩ        | 0               | After restart | Setup                              |                                       |                                     |

Set Pn601 to the capacity of the Dynamic Brake Resistor that you calculated when selecting the connected External Dynamic Brake Resistor or the capacity of the Resistor as reported by the manufacturer.

Refer to the following section for details on the energy consumption of the Dynamic Brake Resistor.

 ◆ *Energy Consumption of the Dynamic Brake Resistor* on page 5-6

## 5.3 Coasting Distances for Dynamic Braking

During dynamic braking, the motor rotates due to inertia until the electrical energy is consumed. The travel distance at this time is called the coasting distance.

This section provides a method for calculating the coasting distance.

### 5.3.1 Coasting Distance during Dynamic Braking

#### CAUTION

- There will be a margin of error between the value calculated for the coasting distance and the actual distance. Therefore, evaluate the operation of the dynamic brake with the actual equipment or machine and confirm that the coasting distance is acceptable. There is a risk of machine damage or injury.

The coasting distance must be checked with the actual equipment, but it can be approximated with the following formulas.

#### Rotary Servomotors

The coasting distance can be calculated with the following formula.

$$\theta = J\{\alpha(R_D + Z_m)Nm_0 + (\beta \times N^3m_0) / (R_D + Z_m)\} + (Nm_0/60) \times T_{D1} \times 360 \text{ [deg]}$$

Calculate the coasting distance using the above formula based on the following conditions.

- $\theta$  [deg]: Coasting distance (mechanical angle)
- $J$  [kgm<sup>2</sup>]: Moment of inertia (motor moment of inertia + load moment of inertia)
- $R_D$  [ $\Omega$ ]: Resistance of Dynamic Brake Resistor
- $Nm_0$  [min<sup>-1</sup>]: Motor speed before starting dynamic braking
- $\alpha, \beta$ : Coasting distance coefficients\*
- $Z_m$ : Characteristic impedance\*
- $T_{D1}$  [s]: Dynamic brake operating time = 5 [ms] or less

\* Refer to the following section for details on the coasting distance coefficients and characteristic impedance.

 5.3.2 Data for Calculating Coasting Distance on page 5-11

#### Linear Servomotors

The coasting distance can be calculated with the following formula.

$$L_m = M\{\alpha(R_D + Z_m)Vm_0 + (\beta \times V^3m_0) / (R_D + Z_m)\} + Vm_0 \times T_{D1} \text{ [m]}$$

Calculate the coasting distance using the above formula based on the following conditions.

- $L_m$  [m]: Coasting distance
- $M$  [kg]: Conveyed mass (Moving Coil mass + load mass)
- $R_D$  [ $\Omega$ ]: Resistance of Dynamic Brake Resistor
- $Vm_0$  [m/s]: Movement speed before starting dynamic braking
- $\alpha, \beta$ : Coasting distance coefficients\*
- $Z_m$ : Characteristic impedance\*
- $T_{D1}$  [s]: Dynamic brake operating time = 5 [ms] or less

\* Refer to the following section for details on the coasting distance coefficients and characteristic impedance.

 5.3.2 Data for Calculating Coasting Distance on page 5-11

## 5.3.2 Data for Calculating Coasting Distance

This section provides the coasting distance coefficients and characteristic impedance required to calculate the coasting distance.

### Coasting Distance Coefficients

The following tables give the relationship between the Servomotor and coasting distance coefficients  $\alpha$  and  $\beta$ .

| Motor Type         | SERVOPACK Model | Servomotor Model | Coasting Distance Coefficients |                              |
|--------------------|-----------------|------------------|--------------------------------|------------------------------|
|                    |                 |                  | $\alpha$                       | $\beta$ [ $\times 10^{-6}$ ] |
| Rotary Servomotors | SGD7W-2R6D      | SGM7G-05D□F      | 3.56                           | 980.46                       |
|                    |                 | SGM7J-02D□F      | 48.85                          | 588.19                       |
|                    |                 | SGM7J-04D□F      | 11.15                          | 317.05                       |
|                    |                 | SGM7A-02D□F      | 33.65                          | 2531.91                      |
|                    | SGD7W-5R4D      | SGM7G-05D□F      | 3.56                           | 980.46                       |
|                    |                 | SGM7J-04D□F      | 11.15                          | 317.05                       |
|                    |                 | SGM7A-04D□F      | 8.50                           | 2710.91                      |
|                    |                 | SGM7G-09D□F      | 3.52                           | 366.36                       |
|                    |                 | SGM7J-08D□F      | 7.61                           | 244.05                       |
|                    |                 | SGM7A-08D□F      | 7.68                           | 520.12                       |
|                    |                 | SGM7G-05D□R      | 8.12                           | 429.13                       |
|                    |                 | SGM7A-15D□F      | 6.85                           | 301.37                       |
|                    |                 | SGM7G-13D□F      | 3.27                           | 133.17                       |
|                    |                 | SGM7A-10D□F      | 9.05                           | 168.32                       |
| Linear Servomotors | SGD7W-2R6D      | SGLFW-35D120A    | 0.94                           | 544.23                       |
|                    |                 | SGLFW-35D230A    | 0.94                           | 132.48                       |
|                    |                 | SGLFW2-30D070A   | 15.62                          | 487.67                       |
|                    |                 | SGLFW2-30D120A   | 4.16                           | 313.30                       |
|                    | SGD7W-5R4D      | SGLFW-50D380B    | 0.95                           | 45.53                        |
|                    |                 | SGLFW-1ZD200B    | 1.15                           | 37.13                        |
|                    |                 | SGLFW2-90D200A   | 0.73                           | 49.83                        |
|                    |                 |                  |                                |                              |

## Characteristic Impedance

The following graphs give the relationship between the characteristic impedance and speed of the Servomotors.

Refer to the graph of the Servomotor that will be used, and use characteristic impedance  $Z_m$  from the speed before starting dynamic braking.

### ◆ Rotary Servomotors

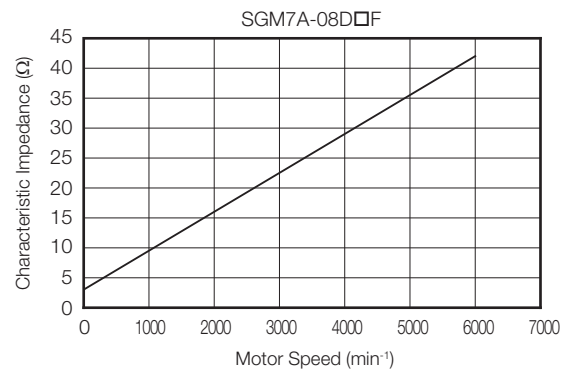
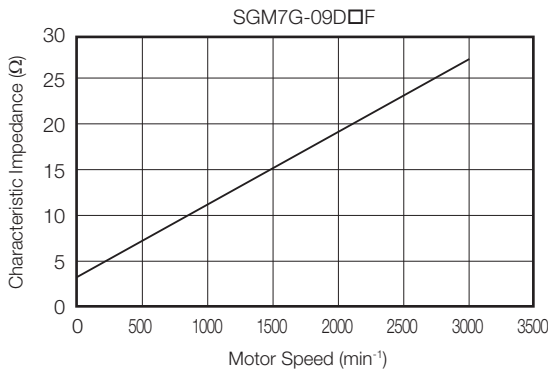
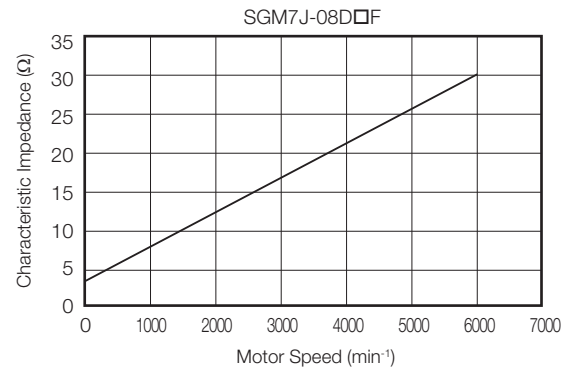
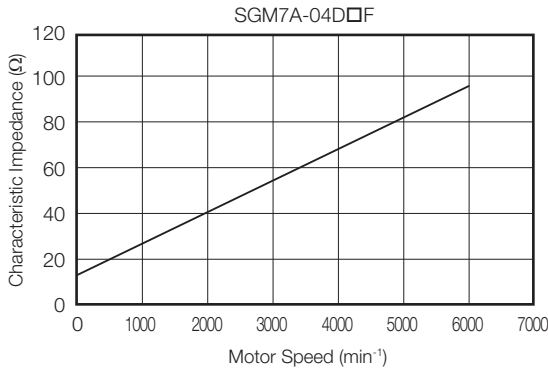
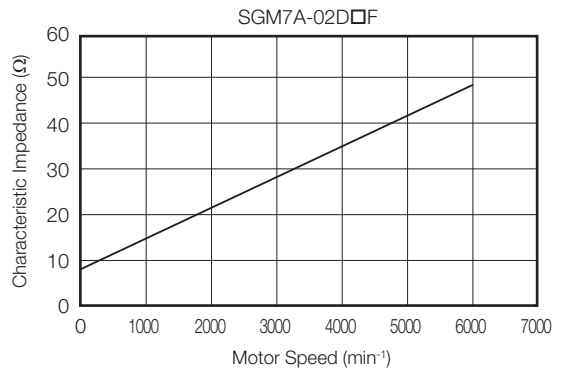
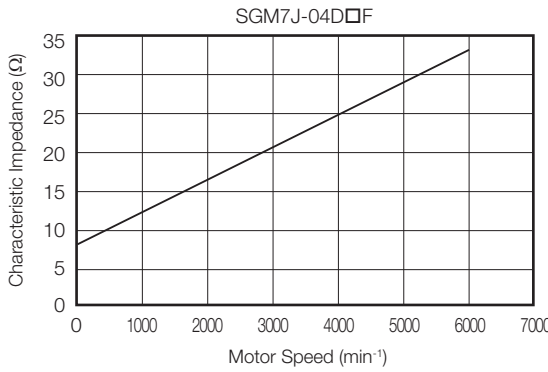
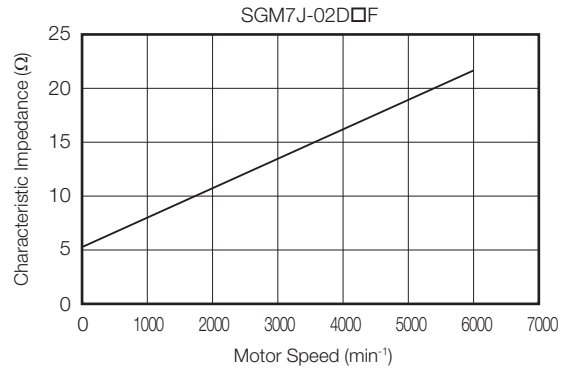
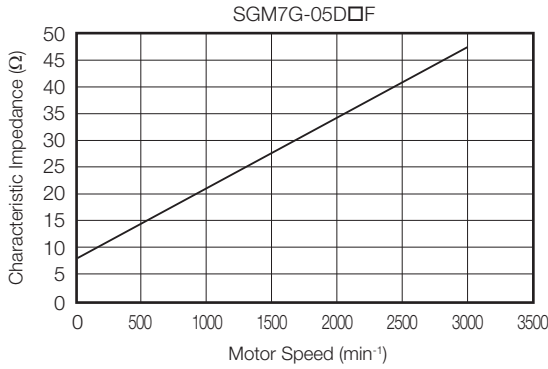



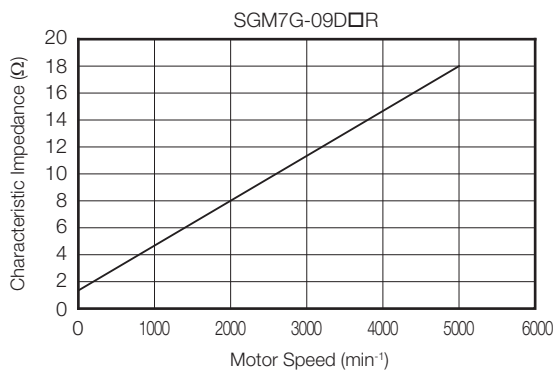
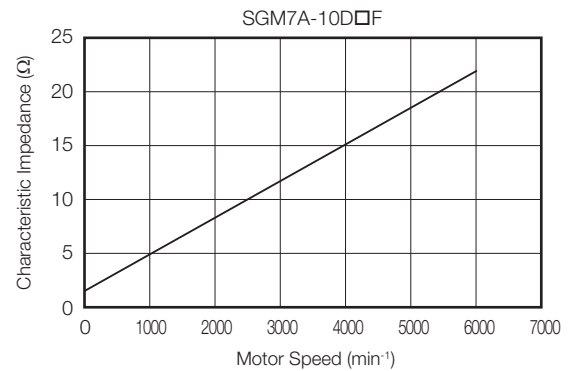
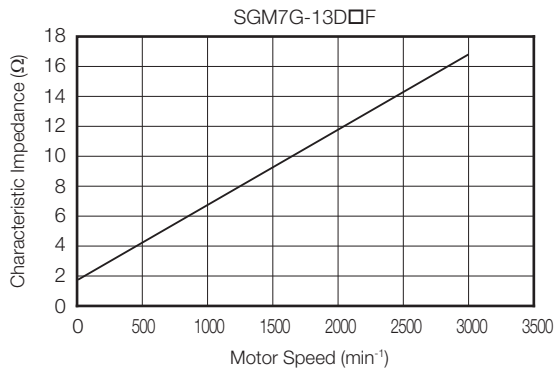
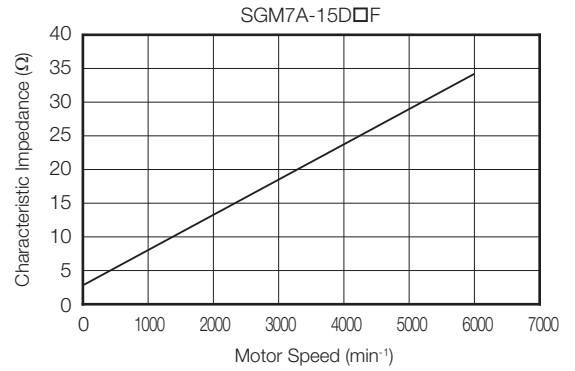
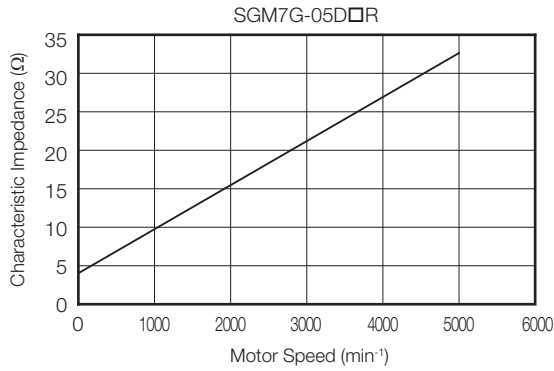

◆ Linear Servomotors

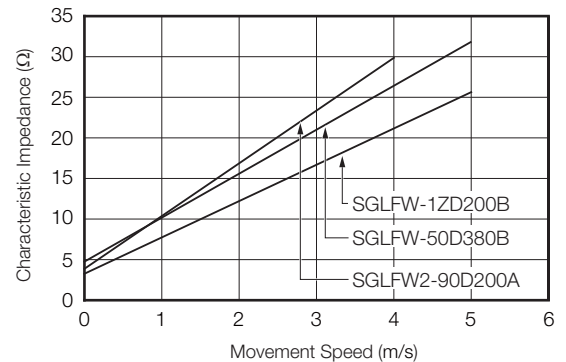
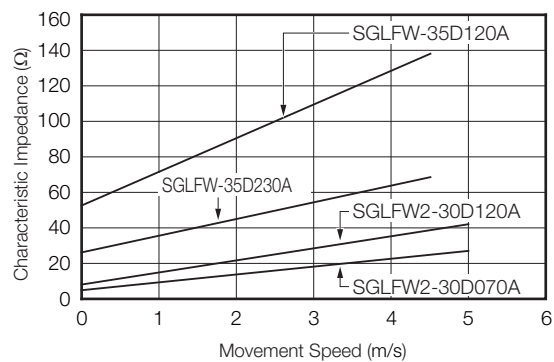

### 5.3 Coasting Distances for Dynamic Braking

---

#### 5.3.2 Data for Calculating Coasting Distance

# Basic Functions That Require Setting before Operation

## 6

This chapter describes the basic functions that must be set before you start Servo System operation. It also describes the setting methods.

|            |   |             |
|------------|---|-------------|
| <b>6.1</b> | <b>Manipulating SERVOPACK Parameters (Pn□□□) . . .</b>                                    | <b>6-3</b>  |
| 6.1.1      | Classifications of SERVOPACK Parameters . . . . .   | 6-3         |
| 6.1.2      | Notation for SERVOPACK Parameters . . . . .   | 6-4         |
| 6.1.3      | SERVOPACK Parameter Setting Methods . . . . .   | 6-5         |
| 6.1.4      | Write Prohibition Setting for SERVOPACK Parameters . . . . .                              | 6-6         |
| 6.1.5      | Initializing SERVOPACK Parameter Settings . . . . .                                       | 6-9         |
| <b>6.2</b> | <b>Power Supply Type Settings for the Main Circuit . . .</b>                              | <b>6-11</b> |
| <b>6.3</b> | <b>Automatic Detection of Connected Motor . . .</b>                                       | <b>6-12</b> |
| <b>6.4</b> | <b>Motor Direction Setting . . . . .</b>  | <b>6-13</b> |
| <b>6.5</b> | <b>Setting the Linear Encoder Pitch . . . . .</b>   | <b>6-14</b> |
| <b>6.6</b> | <b>Writing Linear Servomotor Parameters . . .</b>   | <b>6-15</b> |
| <b>6.7</b> | <b>Selecting the Phase Sequence for a Linear Servomotor . . .</b>                         | <b>6-19</b> |
| <b>6.8</b> | <b>Polarity Sensor Setting . . . . .</b>  | <b>6-21</b> |
| <b>6.9</b> | <b>Polarity Detection . . . . .</b>   | <b>6-22</b> |
| 6.9.1      | Restrictions . . . . .  | 6-22        |
| 6.9.2      | Using the Servo ON Command (Enable Operation Command) to Perform Polarity Detection . . . | 6-23        |
| 6.9.3      | Using a Tool Function to Perform Polarity Detection . . . . .                             | 6-24        |

**6.10 Overtravel and Related Settings . . . . . 6-25**

- 6.10.1 Overtravel Signals . . . . . 6-25
- 6.10.2 Setting to Enable/Disable Overtravel . . . . . 6-26
- 6.10.3 Motor Stopping Method for Overtravel . . . . . 6-26
- 6.10.4 Overtravel Warnings . . . . . 6-28
- 6.10.5 Overtravel Release Method Selection . . . . . 6-29
- 6.10.6 Overtravel Status . . . . . 6-30
- 6.10.7 Overtravel Operation by Mode . . . . . 6-30

**6.11 Holding Brake . . . . . 6-31**

- 6.11.1 Brake Operating Sequence . . . . . 6-31
- 6.11.2 /BK (Brake) Signal . . . . . 6-32
- 6.11.3 Output Timing of /BK (Brake) Signal When  
the Servomotor Is Stopped . . . . . 6-33
- 6.11.4 Output Timing of /BK (Brake) Signal When the  
Servomotor Is Operating . . . . . 6-33
- 6.11.5 Built-in Brake Relay Usage Selection . . . . . 6-35

**6.12 Motor Stopping Methods for Servo OFF and Alarms . . 6-36**

- 6.12.1 Stopping Method for Servo OFF . . . . . 6-37
- 6.12.2 Servomotor Stopping Method for Alarms . . . . . 6-37

**6.13 Motor Overload Detection Level . . . . . 6-39**

- 6.13.1 Detection Timing for Overload Warnings  
(A.910) . . . . . 6-39
- 6.13.2 Detection Timing for Overload Alarms (A.720) . . 6-40

**6.14 Setting Unit Systems . . . . . 6-41**

- 6.14.1 Setting the Position Reference Unit . . . . . 6-41
- 6.14.2 Setting the Speed Reference Unit . . . . . 6-46
- 6.14.3 Setting the Acceleration Reference Unit . . . . . 6-47
- 6.14.4 Setting the Torque Reference Unit . . . . . 6-47
- 6.14.5 Setting the Encoder Resolution . . . . . 6-47

**6.15 Resetting the Absolute Encoder . . . . . 6-48**

- 6.15.1 Precautions on Resetting . . . . . 6-48
- 6.15.2 Preparations . . . . . 6-48
- 6.15.3 Applicable Tools . . . . . 6-48
- 6.15.4 Operating Procedure . . . . . 6-49

**6.16 Setting the Origin of the Absolute Encoder . . 6-51**

- 6.16.1 Absolute Encoder Origin Offset . . . . . 6-51
- 6.16.2 Setting the Origin of the Absolute  
Linear Encoder . . . . . 6-51

**6.17 Setting the Regenerative Resistor Capacity . . . 6-54**

## 6.1

## Manipulating SERVOPACK Parameters (Pn□□□)

This section describes the classifications, notation, and setting methods for the parameters given in this manual.

## 6.1.1 Classifications of SERVOPACK Parameters

There are the following two types of SERVOPACK parameters.

| Classification    | Meaning  |
|-------------------|--|
| Setup Parameters  | Parameters for the basic settings that are required for operation. |
| Tuning Parameters | Parameters that are used to adjust servo performance.              |



Important

When you edit parameters with the SigmaWin+, setup parameters and tuning parameters are displayed.

When you edit parameters with a Digital Operator, only setup parameters are displayed by default. To edit tuning parameters, set Pn00B to n.□□□1 (Display all parameters).

| Parameter        | Meaning                     | When Enabled  | Classification |
|------------------|-----------------------------|---------------|----------------|
| Pn00B<br>(200Bh) | n.□□□0<br>(default setting) | After restart | Setup          |
|                  | n.□□□1                      |               |                |

The setting method for each type of parameter is described below.

## Setup Parameters

You can use the Digital Operator or SigmaWin+ to set the setup parameters individually.

## Information

We recommend that you use the Setup Wizard of the SigmaWin+ to easily set the required setup parameters by setting the operating methods, machine specifications, and I/O signals according to on-screen Wizard instructions.

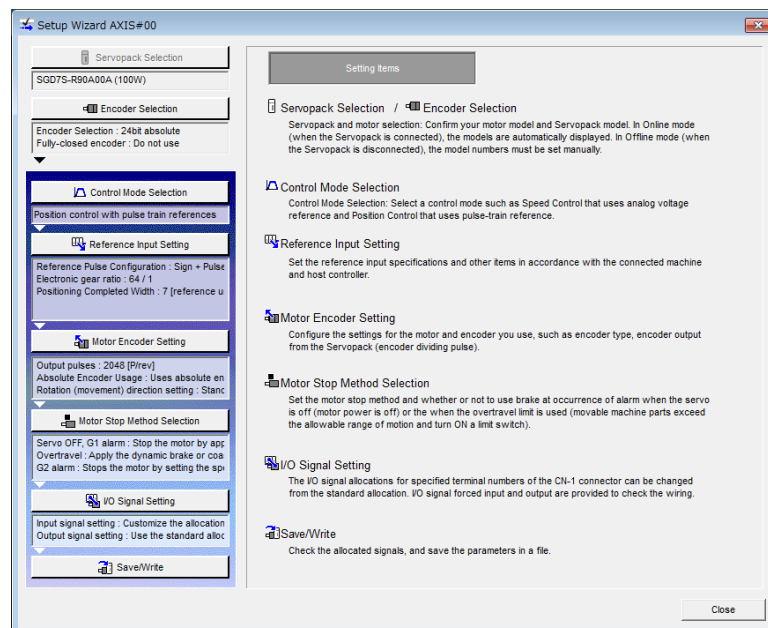

## Tuning Parameters

Normally the user does not need to set the tuning parameters individually.

Use the various SigmaWin+ tuning functions to set the related tuning parameters to increase the response even further for the conditions of your machine. Refer to the following sections for details.

- 📖 9.6 Autotuning without Host Reference on page 9-24
- 📖 9.7 Autotuning with a Host Reference on page 9-35
- 📖 9.8 Custom Tuning on page 9-42

You can also set the tuning parameters individually to make adjustments. Refer to the following section for details.

- 📖 9.13 Manual Tuning on page 9-77

## 6.1.2 Notation for SERVOPACK Parameters

There are two types of notation used for SERVOPACK parameters that depend on whether the parameter requires a numeric setting (parameter for numeric setting) or requires the selection of a function (parameter for selecting a function).

### Parameters for Numeric Settings

Object index number used to access the parameter with EtherCAT (CoE) communications

The control methods for which the parameters apply are given.  
 [Speed] : Speed control [Position] : Position control [Torque] : Torque control

|                  |                 |              |                 |              |                |
|------------------|-----------------|--------------|-----------------|--------------|----------------|
| Pn100<br>(2100h) | Speed Loop Gain |              |                 |              |                |
|                  | Setting Range   | Setting Unit | Default Setting | When Enabled | Classification |
|                  | 10 to 20,000    | 0.1 Hz       | 400             | Immediately  | Tuning         |

If [Common] is given here, the parameter applies to both axes A and B. If you change the setting, the new setting will be applied to both axes.

This is the setting range for the parameter.

This is the minimum unit (setting increment) that you can set for the parameter.

This is the parameter setting before shipment.

This is when any change made to the parameter will become effective.

This is the parameter classification.

### Parameters for Selecting Functions

Object index number used to access the parameter with EtherCAT (CoE) communications

| Parameter                  | Meaning                     | When Enabled  | Classification |
|----------------------------|-----------------------------|---------------|----------------|
| Pn00F<br>(200Fh)<br>Common | n.□□□□<br>(default setting) | After restart | Setup          |
|                            | n.□□□□1                     |               |                |

The notation "n.□□□□" indicates a parameter for selecting functions. Each □ indicates the setting for one digit. The notation shown here means that the first digit from the right is set to 1.

This column explains the selections for the function.

If [Common] is given here, the parameter applies to both axes A and B. If you change the setting, the new setting will be applied to both axes.

## 6.1.3 SERVOPACK Parameter Setting Methods



You can use the SigmaWin+ or a Digital Operator to set SERVOPACK parameters. Use the following procedure to set the SERVOPACK parameters.

### Setting SERVOPACK Parameters with the SigmaWin+

1. Click the  Servo Drive Button in the workspace of the Main Window of the SigmaWin+.

2. Select **Edit Parameters** in the Menu Dialog Box. The Parameter Editing Dialog Box will be displayed.

3. Click the cell of the parameter to edit.

If the parameter to edit is not displayed in the Parameter Editing Dialog Box, click the  or  Button to display the parameter to edit.

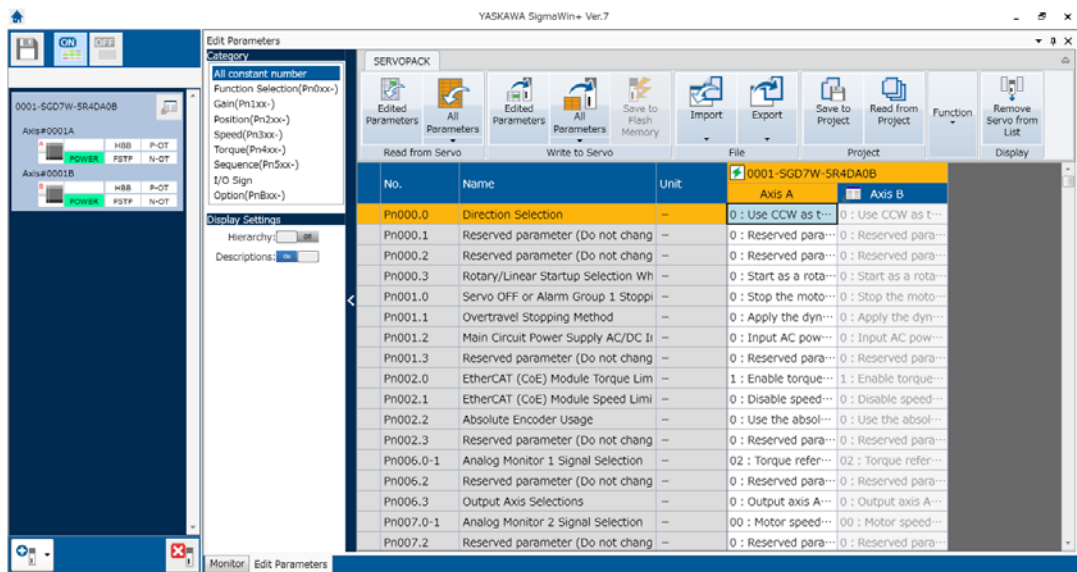

4. Change the setting of the parameter.

#### Information

- For a parameter for a numeric setting, input the numeric setting.
- If the parameter requires selection of a function, select the function from the list of selections.

5. Press the **Enter** Key.

The background of the edited parameter cell will change to green.

6. Select Edited Parameters in the Write to Servo Group.

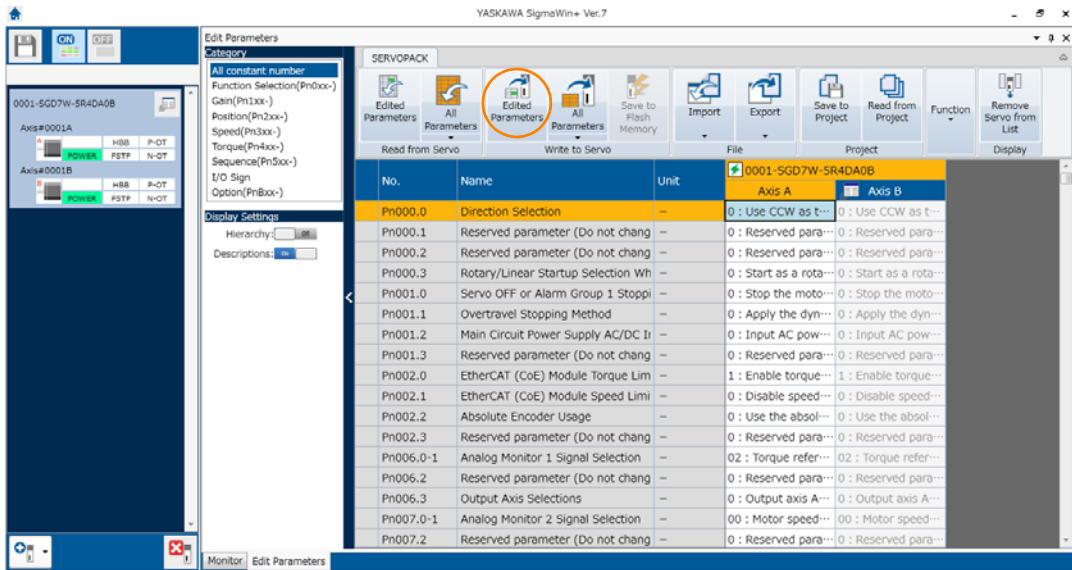

The edited parameters are written to the SERVOPACK and the backgrounds of the cells change to white.

7. Click the OK Button.

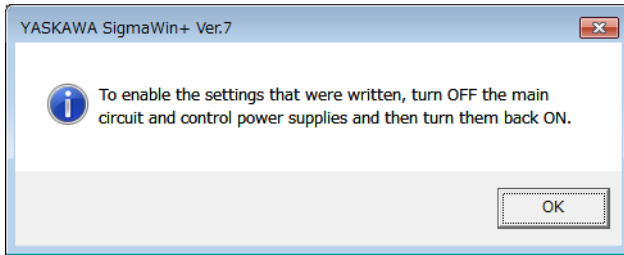

8. To enable changes to the settings, turn the power supply to the SERVOPACK OFF and ON again.

This concludes the procedure to set the SERVOPACK parameters.

## Setting SERVOPACK Parameters with a Digital Operator

Refer to the following manual for information on setting the SERVOPACK parameters with a Digital Operator.

📖  $\Sigma$ -7-Series Digital Operator Operating Manual (Manual No.: SIEP S800001 33)

### 6.1.4 Write Prohibition Setting for SERVOPACK Parameters

You can prohibit writing SERVOPACK parameters from the Digital Operator. Even if you do, you will still be able to change SERVOPACK parameter settings from the SigmaWin+ or with EtherCAT (CoE) communications.



**Important** The write prohibition setting for parameters applies to both axes A and B. If you change the setting, the new setting will be applied to both axes.



## Preparations

No preparations are required.





## Applicable Tools

The following table lists the tools that you can use to change the write prohibition setting for SERVOPACK parameters.

| Tool             | Fn No./Function Name                     | Reference  |
|------------------|--|--|
| Digital Operator | Fn010                                    |  $\Sigma$ -7-Series Digital Operator Operating Manual (Manual No.: SIEP S800001 33) |
| SigmaWin+        | <i>Others - Write Prohibited Setting</i> |  <i>Operating Procedure on page 6-7</i>   |

## Operating Procedure

Use the following procedure to prohibit or permit writing parameter settings.

1. Click the  Servo Drive Button in the workspace of the Main Window of the SigmaWin+.
2. Select **Write Prohibition Setting** in the Menu Dialog Box.  
The Write Prohibition Setting Dialog Box will be displayed.
3. Press the  or  for the rightmost digit and set one of the following.  
0000: Writing is permitted (default setting).  
0001: Writing is prohibited.

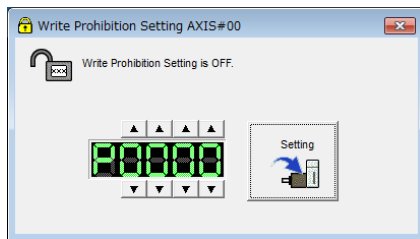

4. Click the **Setting** Button.

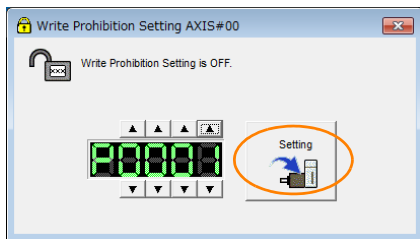

5. Click the **OK** Button.  
The setting will be written to the SERVOPACK.

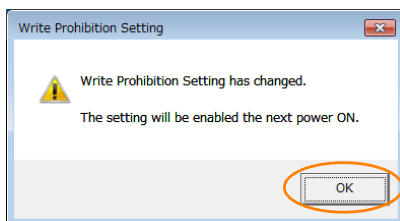

6. To enable the new setting, turn the power supply to the SERVOPACK OFF and ON again.

This concludes the procedure to prohibit or permit writing SERVOPACK parameter settings.

## Restrictions

If you prohibit writing parameter settings, you will no longer be able to execute some functions. Refer to the following table.

| SigmaWin+                 |  | Digital Operator |  | When Writing Is Prohibited | Reference  |
|---------------------------|--|------------------|--|----------------------------|------------|
| Button in Menu Dialog Box | SigmaWin+ Function Name                                | Fn No.           | Utility Function Name  |                            |            |
| Basic Functions           | Initialize *1  | Fn005            | Initializing Parameters  | Cannot be executed.        | page 6-9   |
|                           | Software Reset   | Fn030            | Software Reset   | Can be executed.           | page 7-35  |
|                           | Product Information                                    | Fn011            | Display Servomotor Model   | Can be executed.           | page 10-2  |
|                           |  | Fn012            | Display Software Version   | Can be executed.           |            |
|                           |  | Fn01E            | Display SERVOPACK and Servomotor IDs                             | Can be executed.           |            |
| Fn01F                     | Display Servomotor ID from Feedback Option Module      | Can be executed. |  |                            |            |
| Encoder Setting           | Absolute Encoder Reset                                 | Fn008            | Reset Absolute Encoder   | Cannot be executed.        | page 6-49  |
|                           | Multi-turn Limit Setup                                 | Fn013            | Multiturn Limit Setting after Multiturn Limit Disagreement Alarm | Cannot be executed.        | page 7-31  |
|                           | Search Origin *2                                       | Fn003            | Origin Search  | Cannot be executed.        | page 8-19  |
|                           | Zero Point Position Setting                            | Fn020            | Set Absolute Linear Encoder Origin                               | Cannot be executed.        | page 6-51  |
|                           | Polarity Detection                                     | Fn080            | Polarity Detection   | Cannot be executed.        | page 6-24  |
| Trouble-shooting          | Display Alarm  | Fn000            | Display Alarm History  | Can be executed.           | page 15-42 |
|                           |  | Fn006            | Clear Alarm History  | Cannot be executed.        | page 15-43 |
|                           |  | Fn014            | Reset Option Module Configuration Error                          | Cannot be executed.        |            |
|                           | Reset Motor Type Alarm                                 | Fn021            | Reset Motor Type Alarm   | Cannot be executed.        | page 6-12  |
| Operation                 | Jog  | Fn002            | Jog  | Cannot be executed.        | page 8-7   |
|                           | Program JOG Operation                                  | Fn004            | Jog Program  | Cannot be executed.        | page 8-13  |
| Tuning                    | Tuning - Autotuning without Host Reference             | Fn201            | Advanced Autotuning without Reference                            | Cannot be executed.        | page 9-24  |
|                           | Tuning - Autotuning with Host Reference                | Fn202            | Advanced Autotuning with Reference                               | Cannot be executed.        | page 9-35  |
|                           | Tuning - Custom Tuning                                 | Fn203            | One-Parameter Tuning   | Cannot be executed.        | page 9-42  |
|                           | Tuning - Custom Tuning - Adjust Anti-resonance Control | Fn204            | Adjust Anti-resonance Control                                    | Cannot be executed.        | page 9-50  |
|                           | Tuning - Custom Tuning - Vibration Suppression         | Fn205            | Vibration Suppression  | Cannot be executed.        | page 9-55  |
|                           | Response Level Setting                                 | Fn200            | Tuning-less Level Setting  | Cannot be executed.        | page 9-16  |
| Diagnostic                | Easy FFT   | Fn206            | Easy FFT   | Cannot be executed.        | page 9-93  |

Continued on next page.

Continued from previous page.

| SigmaWin+                 |  | Digital Operator          |   | When Writing Is Prohibited | Reference |
|---------------------------|--|---------------------------|---|----------------------------|-----------|
| Button in Menu Dialog Box | SigmaWin+ Function Name                    | Fn No.                    | Utility Function Name                                 |                            |           |
| Others                    | Adjust the Analog Monitor Output           | Fn00C                     | Adjust Analog Monitor Output Offset                   | Cannot be executed.        | page 10-9 |
|                           |  | Fn00D                     | Adjust Analog Monitor Output Gain                     | Cannot be executed.        |           |
|                           | Adjust the Motor Current Detection Offsets | Fn00E                     | Autotune Motor Current Detection Signal Offset        | Cannot be executed.        | page 7-41 |
|                           |  | Fn00F                     | Manually Adjust Motor Current Detection Signal Offset | Cannot be executed.        |           |
|                           | Initialize Vibration Detection Level       | Fn01B                     | Initialize Vibration Detection Level                  | Cannot be executed.        | page 7-37 |
| Write Prohibited Setting  | Fn010                                      | Write Prohibition Setting | Can be executed.                                      | page 6-6                   |           |

\*1. An **Initialize** Button will be displayed in the Parameter Editing Dialog Box.

\*2. Cannot be used when connecting a Linear Servomotor.

## 6.1.5 Initializing SERVOPACK Parameter Settings

You can return the SERVOPACK parameters to their default settings. You can specify the axis or axes to initialize.

This function will not initialize the settings of the parameters that are adjusted for the Fn00C, Fn00D, Fn00E, and Fn00F utility functions.



To enable the new settings, turn the power supply to the SERVOPACK OFF and ON again after you complete the operation.

### Preparations

Always check the following before you initialize the SERVOPACK parameter settings.

- The SERVOPACK parameters must not be write prohibited.
- The servo must be OFF.

### Applicable Tools

The following table lists the tools that you can use to initialize the SERVOPACK parameter settings.

| Tool             | Fn No./Function Name                     | Reference   |
|------------------|--|---|
| Digital Operator | Fn005                                    | $\Sigma$ -7-Series Digital Operator Operating Manual (Manual No.: SIEP S80001 33) |
| SigmaWin+        | <b>Basic Functions - Edit Parameters</b> | Operating Procedure on page 6-9   |

### Operating Procedure

Use the following procedure to initialize the SERVOPACK parameter settings.

1. Click the Servo Drive Button in the workspace of the Main Window of the SigmaWin+.
2. Select **Edit Parameters** in the Menu Dialog Box.  
The Parameter Editing Dialog Box will be displayed.
3. Select any parameter of the axis to initialize.

4. Select Initialize in the Function Group.

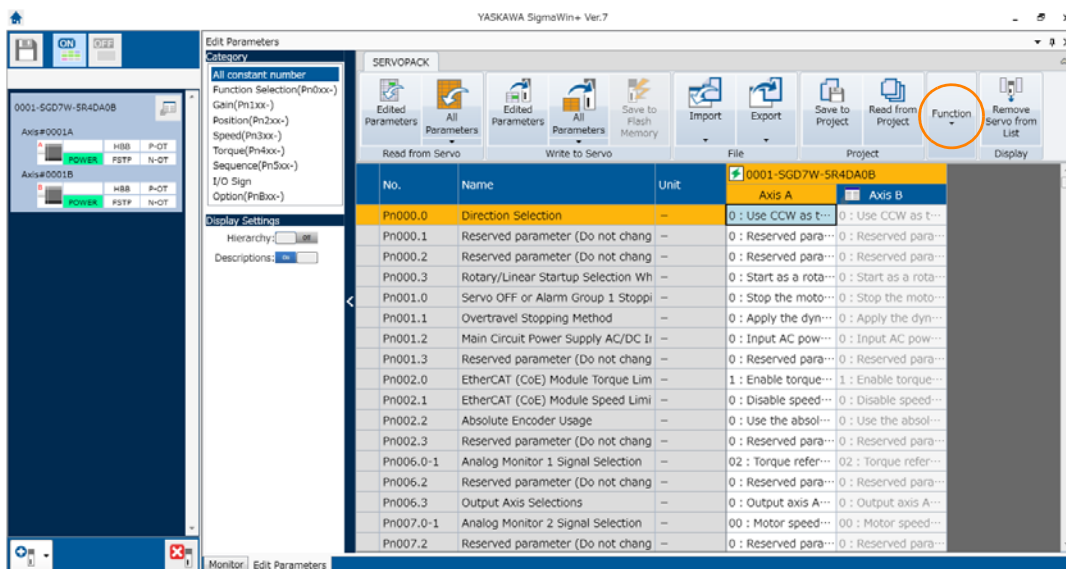

5. Click the OK Button.

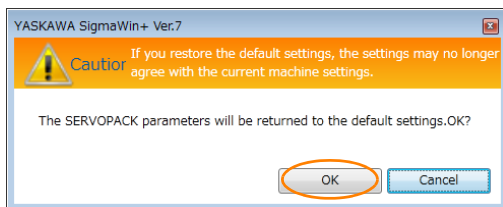

Click the **Cancel** Button to cancel initialization. The Parameter Editing Dialog Box will return.

6. Click the OK Button.

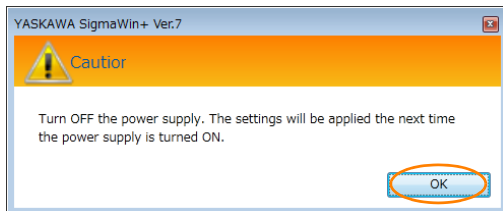

7. Turn the power supply to the SERVOPACK OFF and ON again after the SERVOPACK parameter settings have been initialized.

This concludes the procedure to initialize the SERVOPACK parameter settings.

## 6.2

## Power Supply Type Settings for the Main Circuit

A SERVOPACK can operate on either an AC power supply input or DC power supply input to the main circuits. This section describes the settings related to the power supply.

Set Pn001 = n.□X□□ (Main Circuit Power Supply AC/DC Input Selection) to specify whether to use an AC or DC power supply input for the main circuit power supply to the SERVOPACK.

If the setting of Pn001 = n.□X□□ does not agree with the actual power supply input, an A.330 alarm (Main Circuit Power Supply Wiring Error) will occur.

**Example****Examples of When an A.330 Alarm (Main Circuit Power Supply Wiring Error) Occurs**

- A DC power supply is connected between the B1 and ⊖2 terminals, but an AC power supply input is specified (Pn001 = n.□0□□).
- An AC power supply is input to the L1, L2, and L3 terminals, but a DC power supply is specified (Pn001 = n.□1□□).

| Parameter        | Meaning                     | When Enabled  | Classification |
|------------------|-----------------------------|---------------|----------------|
| Pn001<br>(2001h) | n.□0□□<br>(default setting) | After restart | Setup          |
|                  | n.□1□□                      |               |                |

**WARNING**

- Connect the AC or DC power supplies to the specified SERVOPACK terminals.
  - Connect an AC power supply to the L1, L2, and L3 terminals on the SERVOPACK.
  - Connect a DC power supply to the B1 and ⊖2 terminals and the 24 V and 0 V terminals on the SERVOPACK.
 There is a risk of failure or fire.
- Always specify a DC power supply input (Pn001 = n.□1□□) before you input DC power for the main circuit power supply.  
If you input DC power without specifying a DC power supply input (i.e., without setting Pn001 to n.□1□□), the SERVOPACK's internal elements may burn and may cause fire or damage to the equipment.
- With a DC power supply input, time is required to discharge electricity after the main power supply is turned OFF. A high residual voltage may remain in the SERVOPACK after the power supply is turned OFF. Be careful not to get an electric shock.
- Install fuses on the power supply line if you use DC power.
- The Servomotor returns regenerative energy to the power supply. If you use a SERVOPACK with a DC power supply input, regenerative energy is not processed. Process the regenerative energy at the power supply.

Refer to the following section for information on wiring the SERVOPACK.

 4.3.4 Power Supply Wiring Diagrams on page 4-15

## 6.3 Automatic Detection of Connected Motor

You can use a SERVOPACK to operate either a Rotary Servomotor or a Linear Servomotor.

If you connect the Servomotor encoder to the CN2A or CN2B connector on the SERVOPACK, the SERVOPACK will automatically determine which type of Servomotor is connected. Therefore, you normally do not need to specify the motor type.

### Information

If an encoder is not connected, e.g., for a test without a motor, you can specify a Rotary Servomotor or a Linear Servomotor in Pn000 = n.X□□□ (Rotary/Linear Servomotor Startup Selection When Encoder Is Not Connected). If you specify either a Rotary or Linear Servomotor, only the parameters, monitors, alarms, and functions for the specified motor type will be enabled.

| Parameter        |                             | Meaning   | When Enabled  | Classification |
|------------------|-----------------------------|---|---------------|----------------|
| Pn000<br>(2000h) | n.0□□□<br>(default setting) | When an encoder is not connected, start as SERVOPACK for Rotary Servomotor. | After restart | Setup          |
|                  | n.1□□□                      | When an encoder is not connected, start as SERVOPACK for Linear Servomotor. |               |                |

## 6.4 Motor Direction Setting

You can reverse the direction of Servomotor rotation by changing the setting of Pn000 = n.□□□X (Rotation Direction Selection) without changing the polarity of the speed or position reference.

### • Rotary Servomotors

The default setting for forward rotation is counterclockwise (CCW) as viewed from the load end of the Servomotor.

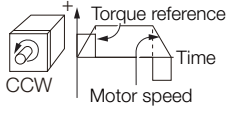
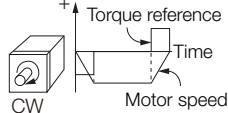
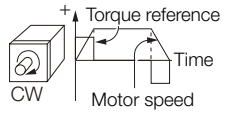
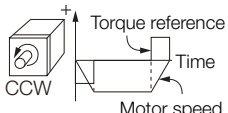
| Parameter        | Forward/Reverse Reference   | Motor Direction   | Applicable Overtravel Signal (OT)    |
|------------------|---|---|--------------------------------------|
| Pn000<br>(2000h) | n.□□□0<br>Use CCW as the forward direction.<br>(default setting)      | Forward reference<br>   | P-OT (Forward Drive Prohibit) signal |
|                  |   | Reverse reference<br>   | N-OT (Reverse Drive Prohibit) signal |
|                  | n.□□□1<br>Use CW as the forward direction.<br>(Reverse Rotation Mode) | Forward reference<br>   | P-OT (Forward Drive Prohibit) signal |
|                  |   | Reverse reference<br> | N-OT (Reverse Drive Prohibit) signal |

Note: The trace waveforms of the SigmaWin+ are shown in the above table for the torque reference and motor speed diagrams. If you measure them on a measuring instrument, e.g., with an analog monitor, the polarity will be reversed.

### • Linear Servomotors

Before you set this parameter, make sure that Pn080 = n.□□□□ (Motor Phase Sequence Selection) is set correctly.

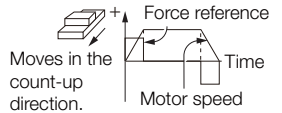
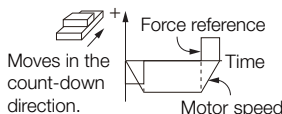
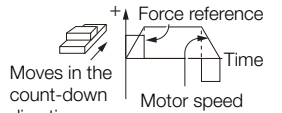
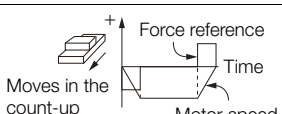
| Parameter        | Forward/Reverse Reference  | Motor Moving Direction  | Applicable Overtravel Signal (OT)    |
|------------------|--|---|--------------------------------------|
| Pn000<br>(2000h) | n.□□□0<br>Use the direction in which the linear encoder counts up as the forward direction.<br>(default setting) | Forward reference<br> | P-OT (Forward Drive Prohibit) signal |
|                  |  | Reverse reference<br> | N-OT (Reverse Drive Prohibit) signal |
|                  | n.□□□1<br>Use the direction in which the linear encoder counts down as the forward direction.                    | Forward reference<br> | P-OT (Forward Drive Prohibit) signal |
|                  |  | Reverse reference<br> | N-OT (Reverse Drive Prohibit) signal |

Note: The trace waveforms of the SigmaWin+ are shown in the above table for the force reference and motor speed diagrams. If you measure them on a measuring instrument, e.g., with an analog monitor, the polarity will be reversed.

# 6.5 Setting the Linear Encoder Pitch

If you connect a linear encoder to the SERVOPACK through a Serial Converter Unit, you must set the scale pitch of the linear encoder in Pn282.

If a Serial Converter Unit is not connected, the setting of the Pn282 is disabled.



Term

**Serial Converter Unit**  
The Serial Converter Unit converts the signal from the linear encoder into a form that can be read by the SERVOPACK.

**Scale Pitch**  
A linear encoder has a scale for measuring lengths (positions). The length of one division on this scale is the scale pitch.

| Pn282<br>(2282h) | Linear Encoder Scale Pitch |              |                 |               |                |
|------------------|----------------------------|--------------|-----------------|---------------|----------------|
|                  | Setting Range              | Setting Unit | Default Setting | When Enabled  | Classification |
|                  | 0 to 6,553,600             | 0.01 μm      | 0               | After restart | Setup          |

You will not be able to control the Linear Servomotor if Pn282 is not set correctly. Check the above table and always set the correct value before you operate the Linear Servomotor.

| Type of Linear Encoder         | Manufacturer                 | Model           | Serial Converter Unit Model | Linear Encoder Pitch [μm] |
|--------------------------------|------------------------------|-----------------|-----------------------------|---------------------------|
| Incremental                    | Dr. JOHANNES HEIDENHAIN GmbH | LIDA48□         | JZDP-H003-□□□-E             | 20                        |
|                                |                              |                 | JZDP-J003-□□□-E             |                           |
|                                | LIF48□                       | JZDP-H003-□□□-E | 4                           |                           |
|                                |                              | JZDP-J003-□□□-E |                             |                           |
|                                | Renishaw PLC                 | RGH22B          | JZDP-H005-□□□-E             | 20                        |
|                                |                              |                 | JZDP-J005-□□□-E             |                           |
| TONIC series (Ti0000A00V only) |                              | JZDP-H005-□□□-E | 20                          |                           |
|                                |                              | JZDP-J005-□□□-E |                             |                           |

The first time you supply power to the SERVOPACK, the panel display on the front of the Servomotor will display an A.080 alarm (Linear Encoder Pitch Setting Error). The A.080 alarm is displayed because the setting of Pn282 has not been changed. The A.080 alarm will be cleared when you change the setting of Pn282 and then turn the power supply OFF and ON again.

**Information** **Linear Encoder Pitch**  
If you do not use a Serial Converter Unit, the linear encoder pitch is automatically set and the setting of the Pn282 is disabled. Refer to the following section for details.

 ■ *Feedback Resolution of Linear Encoder* on page 6-43



# 6.6 Writing Linear Servomotor Parameters

If you connect a linear encoder to the SERVOPACK without going through a Serial Converter Unit, you must use the SigmaWin+ to write the motor parameters to the linear encoder. The motor parameters contain the information that is required by the SERVOPACK to operate the Linear Servomotor.

**WARNING**

- Check the motor and linear encoder information before you write the motor parameters. If you do not write the correct motor parameters, the motor may run out of control or burning may occur, possibly resulting in equipment damage or fire.

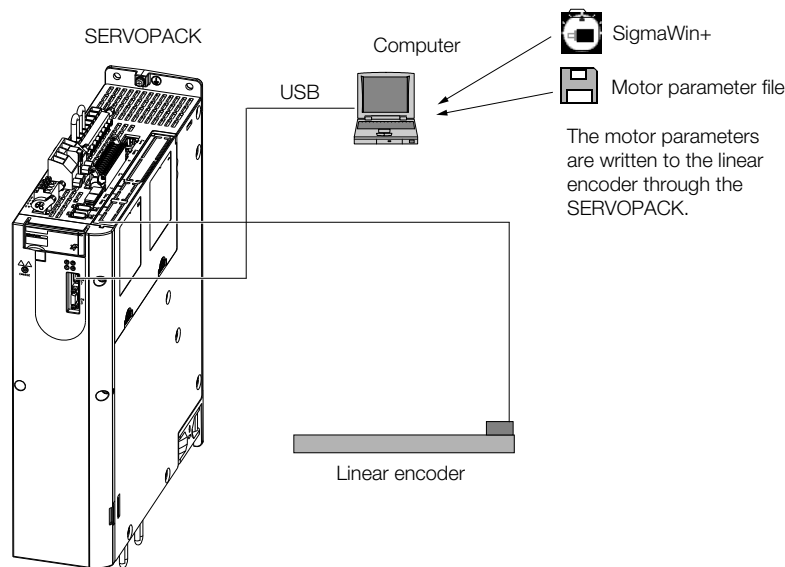

**Important**

Serial number information is not included in the motor parameters. You cannot use the monitor functions of the SERVOPACK to monitor the serial number. If you attempt to monitor the serial number, \*\*\*\*\* will be displayed.

## Precautions

- If the encoder parameters are not written to the linear encoder, an A.CA0 alarm (Encoder Parameter Error) will occur. Consult the manufacturer of the linear encoder.
- If the motor parameters are not written to the linear encoder, an A.CA0 alarm (Encoder Parameter Error) will not occur, but the following alarms will occur.  
 A.040 (Parameter Setting Error), A.050 (Combination Error),  
 A.051 (Unsupported Device Alarm), A.550 (Maximum Speed Setting Error),  
 A.710 (Instantaneous Overload), A.720 (Continuous Overload), and  
 A.C90 (Encoder Communications Error)

## Applicable Tools

The following table lists the tools that you can use to write the parameters to the Linear Servomotor.

| Tool             | Fn No./Function Name   | Reference                        |
|------------------|--|----------------------------------|
| Digital Operator | You cannot write Linear Servomotor parameters from the Digital Operator. |                                  |
| SigmaWin+        | <b>Encoder Setting – Motor Parameter Scale Write</b>                     | Operating Procedure on page 6-16 |

## Operating Procedure

Use the following procedure to write the motor parameters to the linear encoder.

1. Prepare the motor parameter file to write to the linear encoder.
2. Click the  Servo Drive Button in the workspace of the Main Window of the SigmaWin+.
3. Select **Motor Parameter Scale Write** in the Menu Dialog Box.  
The Motor Parameter Scale Write Dialog Box will be displayed.
4. Click the **OK** Button.

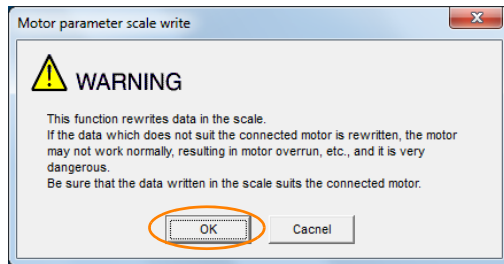

Click the **Cancel** Button to cancel writing the motor parameters to the linear encoder. The Main Window will return.

If the write is completed normally, the Motor Parameter Scale Write - File Select Dialog Box will be displayed.

5. Click the **Ref.** Button.

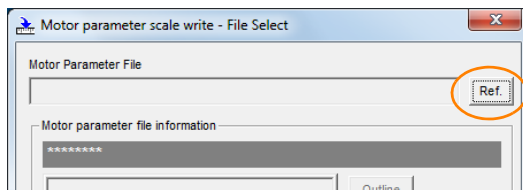

6. Select the motor parameter file that you prepared and click the **Open** Button.

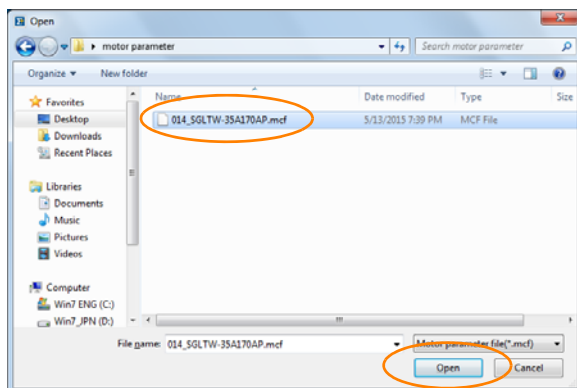

- 7. Confirm that the motor parameter file information that is displayed is suitable for your motor, and then click the **Next Button**.

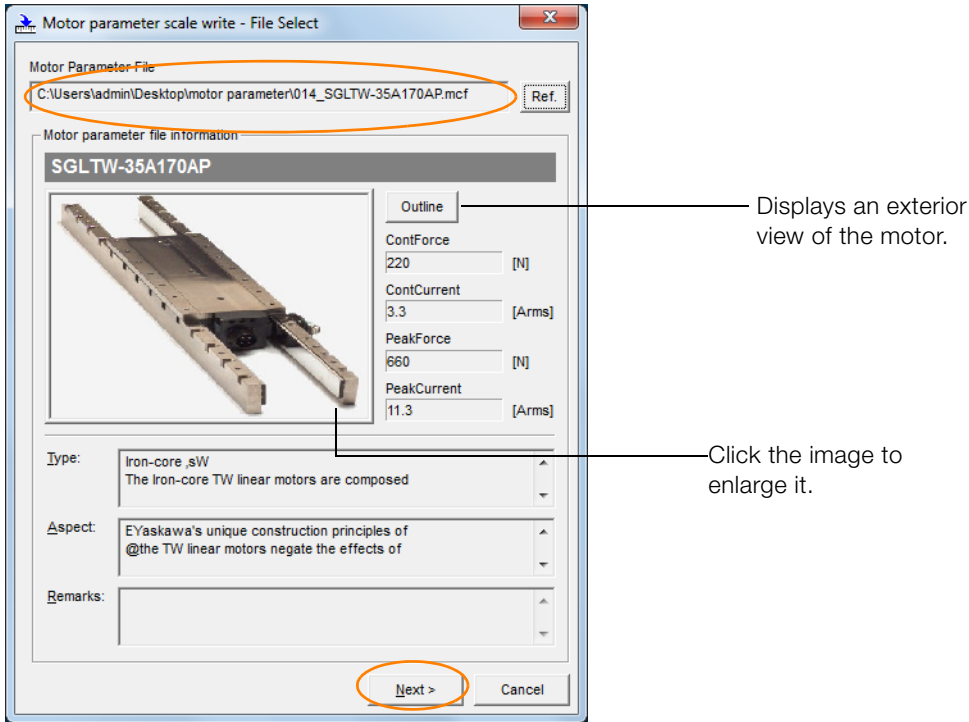

Click the **Cancel** Button to cancel writing the motor parameters to the linear encoder. The Main Window will return.

- 8. Click the **Write Button**.

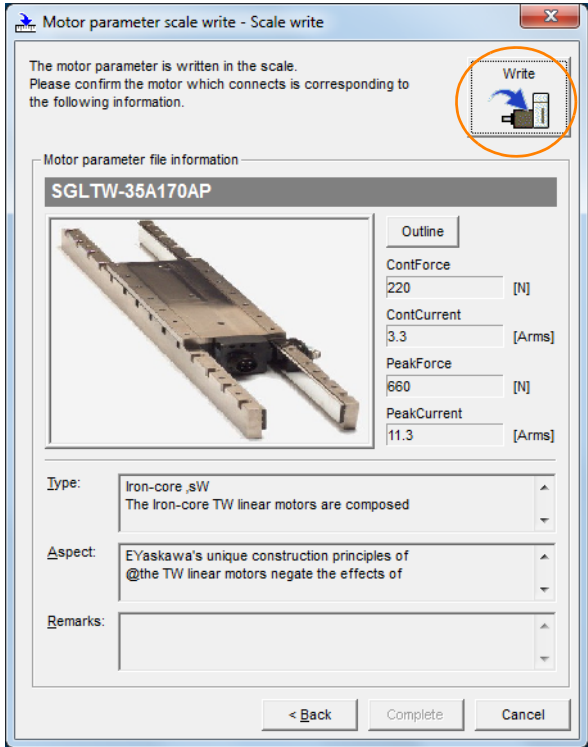

9. Click the Yes Button.

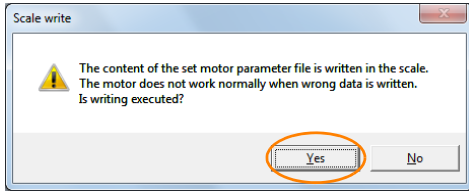

Click the **No** Button to cancel writing the motor parameters to the linear encoder. If you click the **Yes** Button, writing the motor parameter scale will start.

10. Click the Complete Button.

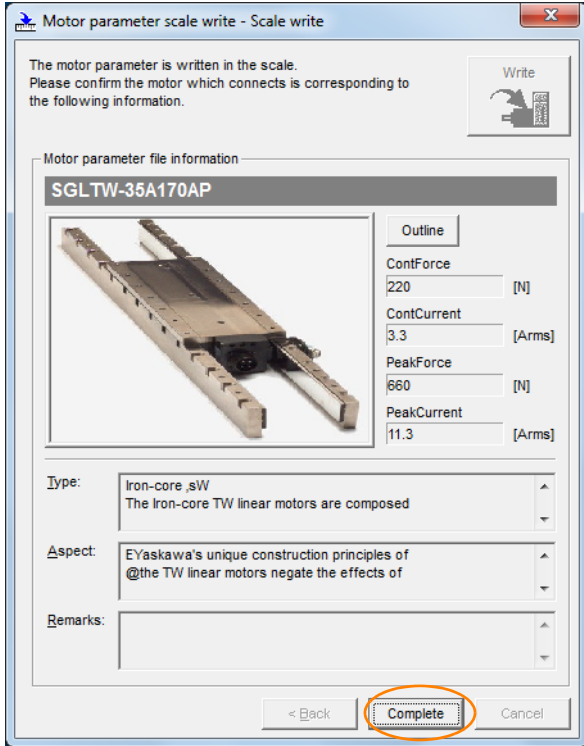

11. Click the OK Button.

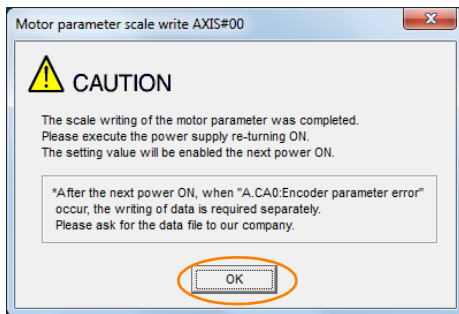

12. Turn the power supply to the SERVOPACK OFF and ON again.

This concludes the procedure to write the motor parameters.

### Confirming If the Motor Parameters Have Been Written

After you write the motor parameters, you can use a monitor function to confirm that the motor parameters are in the encoder.

If the motor parameters have not been written, no information on the Servomotor will be displayed.

10.1 Monitoring Product Information on page 10-2

## 6.7

## Selecting the Phase Sequence for a Linear Servomotor

You must select the phase sequence of the Linear Servomotor so that the forward direction of the Linear Servomotor is the same as the encoder's count-up direction.

Before you set the Linear Servomotor phase sequence (Pn080 = n.□□X□), check the following items.

- Confirm that the signal from the linear encoder is being received normally.
- Make sure that the forward direction of the Linear Servomotor and the count-up direction of the linear encoder are in the same direction.



Important

If you do not confirm the above items before you attempt to operate the motor, the motor may not operate or it may run out of control. Always confirm these items before you operate the motor.

## Related Parameters

| Parameter        | Meaning                     | When Enabled  | Classification |
|------------------|-----------------------------|---------------|----------------|
| Pn080<br>(2080h) | n.□□0□<br>(default setting) | After restart | Setup          |
|                  | n.□□1□                      |               |                |

## Operating Procedure

Use the following procedure to select the phase sequence for a Linear Servomotor.

1. Set Pn000 to n.□□□0 (Set a phase-A lead as a phase sequence of U, V, and W).  
This setting is to make following confirmation work easier to understand.
2. **Select Monitor in the Menu Dialog Box.**  
The Operation Pane will be displayed so that you can check the feedback pulse counter.  
To check the feedback pulse counter with the Digital Operator, use Un00D (Feedback Pulse Counter).
3. **Manually move the Moving Coil from one end to the other of the stroke and confirm that only the correct number of feedback pulses is returned.**  
If the correct number and only the correct number of pulses is returned, the signal is being received correctly from the linear encoder.

**Example**

In this example, assume that a linear encoder with a scale pitch of 20 μm and a resolution of 256 is used. If you manually move the Moving Coil 1 cm in the count-up direction of the linear encoder, the number of feedback pulses would be as follows:  
 $1 \text{ cm} / (20 \text{ μm} / 256) = 128,000 \text{ pulses}$

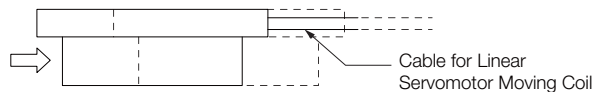

If there are 128,000 pulses on the feedback pulse counter after you manually move the Moving Coil in the direction of the cable, you have completed the confirmation.

Note: The actual monitor display will be offset by the error in the travel distance. There is no problem as long as the above value is close to the calculated value.

**Information**

If the correct value is not displayed for the feedback pulse counter, the following conditions may exist. Check the situation and correct any problems.

- The linear encoder pitch is not correct.  
If the scale pitch that is set in Pn282 does not agree with the actual scale pitch, the expected number of feedback pulses will not be returned. Check the specifications of the linear encoder.
- The linear encoder is not adjusted properly.  
If the linear encoder is not adjusted properly, the output signal level from the linear encoder will drop and the correct number of pulses will not be counted. Check the adjustment of the linear encoder. Contact the manufacturer of the linear encoder for details.
- There is a mistake in the wiring between the linear encoder and the Serial Converter Unit.  
If the wiring is not correct, the correct number of pulses will not be counted. Correct the wiring.

4. Manually move the Moving Coil in the direction of the cable and check the value of the feedback pulse counter in the Operation Pane to confirm that it is counting up.  
If the pulses are counted up, the forward direction of the Linear Servomotor is the same as the count-up direction of the linear encoder.

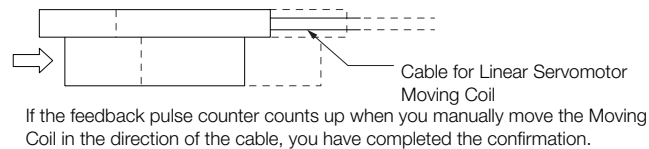

5. If the feedback pulse counter counts down, set a phase-B lead as a phase sequence of U, V, and W (Pn080 = n.□□1□) and turn the power supply OFF and ON again.
6. If necessary, return Pn000 = n.□□□X (Direction Selection) to its original setting.

This concludes the procedure to set the phase sequence of the Linear Servomotor.

## 6.8 Polarity Sensor Setting

The polarity sensor detects the polarity of the Servomotor. You must set a parameter to specify whether the Linear Servomotor that is connected to the SERVOPACK has a polarity sensor. Specify whether there is a polarity sensor in Pn080 = n.□□□X (Polarity Sensor Selection).

If the Linear Servomotor has a polarity sensor, set Pn080 to n.□□□0 (Use polarity sensor) (default setting).

If the Linear Servomotor does not have a polarity sensor, set Pn080 to n.□□□1 (Do not use polarity sensor). Turn the power supply OFF and ON again to enable the new setting.

| Parameter        |                             | Meaning                     | When Enabled  | Classification |
|------------------|-----------------------------|-----------------------------|---------------|----------------|
| Pn080<br>(2080h) | n.□□□0<br>(default setting) | Use polarity sensor.        | After restart | Setup          |
|                  | n.□□□1                      | Do not use polarity sensor. |               |                |

**Information** If you set Pn080 to n.□□□0 (Use polarity sensor) and the Linear Servomotor that is connected to the SERVOPACK does not have a polarity sensor, an A.C21 alarm (Polarity Sensor Error) will occur when you turn the power supply OFF and ON again.

## 6.9 Polarity Detection

If you use a Linear Servomotor that does not have a polarity sensor, then you must detect the polarity.

Detecting the polarity means that the position of the electrical angle phase on the electrical angle coordinates of the Servomotor is detected. The SERVOPACK cannot control the Servomotor correctly unless it accurately knows the position of the electrical angle coordinate of the Servomotor.

The execution timing and execution method for polarity detection depend on the encoder specification as described in the following table.

| Encoder Specification | Polarity Detection Execution Timing   | Polarity Detection Execution Method   |
|-----------------------|---|---|
| Incremental encoder   | Each time the control power supply to the SERVOPACK is turned ON (Even after you execute polarity detection, the position of the polarity will be lost the next time the control power supply to the SERVOPACK is turned OFF.)                      | <ul style="list-style-type: none"> <li>• Use the Servo ON command (Enable Operation command).</li> <li>• Use the polarity detection function of the SigmaWin+.</li> <li>• Execute the Fn080 (Polarity Detection) utility function from the Digital Operator.</li> </ul> |
| Absolute encoder      | Only for initial setup, or after the SERVOPACK, linear encoder, or motor has been replaced (The results of polarity detection is stored in the absolute encoder, so the polarity position is not lost when the control power supply is turned OFF.) | <ul style="list-style-type: none"> <li>• Use the polarity detection function of the SigmaWin+.</li> <li>• Execute the Fn080 (Polarity Detection) utility function from the Digital Operator.</li> </ul>   |

**Information** If you use a Linear Servomotor that does not have a polarity sensor, you will not be able to turn ON the servo until polarity detection has been completed.

## 6.9.1 Restrictions

### Assumed Conditions

The Servomotor will move when you execute polarity detection. The following conditions must be met before you start.

- It must be OK to move the Moving Coil about 10 mm. (If polarity detection fails, the Moving Coil may move approximately 5 cm. The amount of movement depends on conditions.)
- The linear encoder pitch must be 100  $\mu\text{m}$  or less. (We recommend a pitch of 40  $\mu\text{m}$  or less for an incremental encoder.)
- As much as possible, the motor must not be subjected to an imbalanced external force. (We recommend 5% or less of the rated force.)
- The mass ratio must be 50x or less.
- The axis must be horizontal.
- There must be friction equivalent to a few percent of the rated force applied to the guides. (Air sliders cannot be used.)

### Preparations

Check the following settings before you execute polarity detection.

- Not using a polarity sensor must be specified (Pn080 = n.□□□1).
- The servo must be OFF for both axis A and axis B.
- The main circuit power supply must be ON.
- There must be no hard wire base block (HWBB).
- There must be no alarms except for an A.C22 alarm (Phase Information Disagreement).



## 6.9.2 Using the Servo ON Command (Enable Operation Command) to Perform Polarity Detection

- The parameters must not be write prohibited. (This item applies only when using the SigmaWin+ or Digital Operator.)
- The test without a motor function must be disabled (Pn00C = n.□□□0).
- There must be no overtravel.
- If the motor parameters have been written or the origin of the absolute linear encoder has been set, the power supply to the SERVOPACK must be turned OFF and ON again after completion of the writing or setting operation.



Important

1. Power is supplied to the Servomotor during polarity detection. Be careful not to get an electric shock. Also, the Moving Coil of the Linear Servomotor may greatly move during detection. Do not approach the moving parts of the Servomotor.
2. Polarity detection is affected by many factors. For example, polarity detection may fail if the mass ratio or friction is too large or the cable tension is too strong.

## 6.9.2 Using the Servo ON Command (Enable Operation Command) to Perform Polarity Detection

You can use the Servo ON command (Enable Operation command) to perform polarity detection only with an incremental linear encoder.

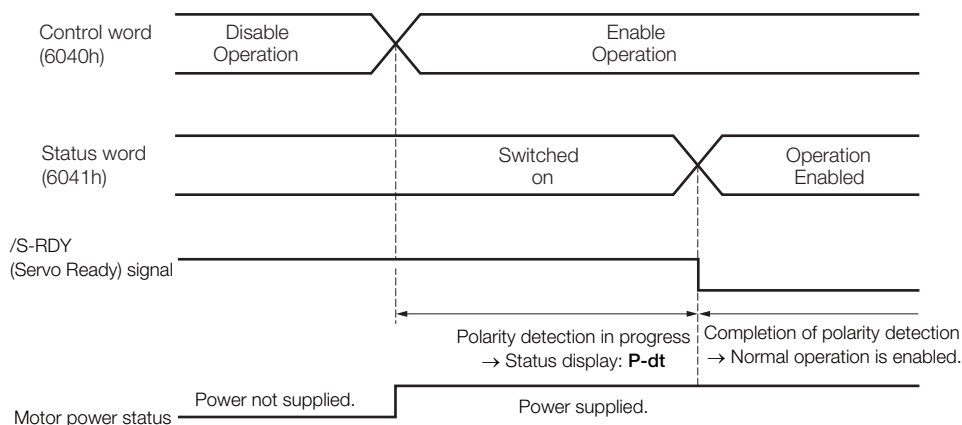

Polarity detection will start simultaneously with execution of the Servo ON command (Enable Operation command). As soon as polarity detection is completed, the /S-RDY will turn ON and the servo will change to ON status (*status word = operation enabled*).



## 6.9.3 Using a Tool Function to Perform Polarity Detection

### Applicable Tools

The following table lists the tools that you can use to perform polarity detection.

| Tool             | Fn No./Function Name                        | Reference   |
|------------------|---|---|
| Digital Operator | Fn080                                       |  $\Sigma$ -7-Series Digital Operator Operating Manual (Manual No.: SIEP S800001 33) |
| SigmaWin+        | <i>Encoder Setting - Polarity Detection</i> |  <i>Operating Procedure</i> on page 6-24  |

### Operating Procedure

Use the following procedure to perform polarity detection.

1. Click the  Servo Drive Button in the workspace of the Main Window of the SigmaWin+.
2. Select **Polarity Detection** in the Menu Dialog Box.  
The Polarity Detection Dialog Box will be displayed.
3. Click the **Continue** Button.

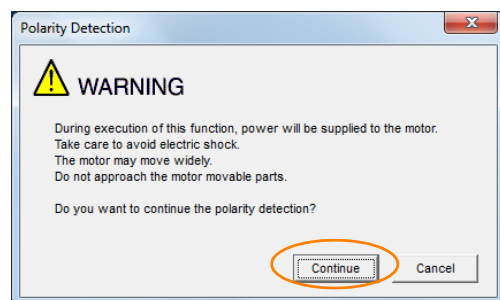

Click the **Cancel** Button to cancel polarity detection. The Main Window will return.

4. Click the **Start** Button.  
Polarity detection will be executed.

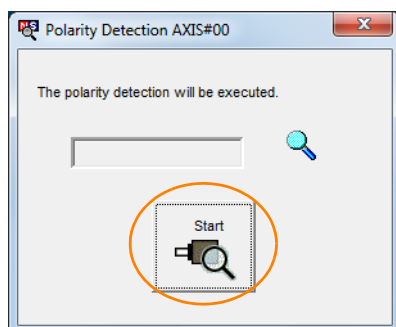

This concludes the polarity detection procedure.

## 6.10 Overtravel and Related Settings

Overtravel is a function of the SERVOPACK that forces the Servomotor to stop in response to a signal input from a limit switch that is activated when a moving part of the machine exceeds the safe range of movement.

The overtravel signals include the P-OT (Forward Drive Prohibit) and the N-OT (Reverse Drive Prohibit) signals.

You use the P-OT and N-OT signals to stop the machine by installing limit switches at the positions where you want to stop the machine that is operated by the Servomotor.

A SERVOPACK wiring example is provided below.

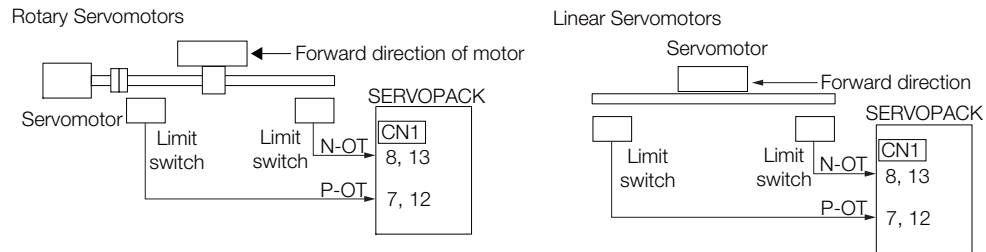

Using the overtravel function is not necessary for rotating applications such as rotary tables and conveyors. No wiring for overtravel input signals is required.

This section describes the parameters settings related to overtravel.

### CAUTION

- To prevent accidents that may result from contact faults or disconnections, use normally closed limit switches.  
Do not change the default settings of the polarity of the overtravel signals (P-OT and N-OT).
- If you use a Servomotor for a vertical axis, the /BK (Brake) signal will remain ON (i.e., the brake will be released) when overtravel occurs. This may result in the workpiece falling when overtravel occurs. To prevent the workpiece from falling, set Pn001 to n.□□1□ to place the Servomotor in a zero-clamped state when it stops.
- A base block state is entered after stopping for overtravel. This may cause the Servomotor to be pushed back by an external force on the load shaft. To prevent the Servomotor from being pushed back, set Pn001 to n.□□1□ to place the Servomotor in a zero-clamped state when it stops.

### 6.10.1 Overtravel Signals

The overtravel signals include the P-OT (Forward Drive Prohibit) and the N-OT (Reverse Drive Prohibit) signals.

| Type  | Signal | Connector Pin No.               | Signal Status | Meaning   |
|-------|--------|---------------------------------|---------------|---|
| Input | P-OT   | Axis A: CN1-7<br>Axis B: CN1-12 | ON            | Forward drive is enabled (actual operation).      |
|       |        |                                 | OFF           | Forward drive is prohibited (forward overtravel). |
|       | N-OT   | Axis A: CN1-8<br>Axis B: CN1-13 | ON            | Reverse drive is enabled (actual operation).      |
|       |        |                                 | OFF           | Reverse drive is prohibited (reverse overtravel). |

You can operate the Servomotor in the opposite direction during overtravel by inputting a reference.

## 6.10.2 Setting to Enable/Disable Overtravel

You can use Pn50A = n.X□□□ (P-OT (Forward Drive Prohibit) Signal Allocation) and Pn50B = n.□□□X (N-OT (Reverse Drive Prohibit) Signal Allocation) to enable and disable the overtravel function.

You do not need to wire the overtravel input signals if you are not going to use the overtravel function.

| Parameter        |                             | Meaning   | When Enabled  | Classification |
|------------------|-----------------------------|---|---------------|----------------|
| Pn50A<br>(250Ah) | n.1□□□<br>(default setting) | The forward overtravel function is enabled and the P-OT (Forward Drive Prohibit) signal is input from CN1-7 for axis A and CN1-12 for axis B. | After restart | Setup          |
|                  | n.8□□□                      | The reverse overtravel function is disabled. Forward drive is always enabled.   |               |                |
| Pn50B<br>(250Bh) | n.□□□2<br>(default setting) | The reverse overtravel function is enabled and the N-OT (Reverse Drive Prohibit) signal is input from CN1-8 for axis A and CN1-13 for axis B. |               |                |
|                  | n.□□□8                      | The reverse overtravel function is disabled. Reverse drive is always enabled.   |               |                |

You can allocate the P-OT and N-OT signals to other connector pins. Refer to the following section for details.

 7.1.1 Input Signal Allocations on page 7-4

## 6.10.3 Motor Stopping Method for Overtravel

You can set the stopping method of the Servomotor when overtravel occurs in Pn001 = n.□□XX (Servo OFF or Alarm Group 1 Stopping Method and Overtravel Stopping Method).

| Parameter        |  | Motor Stopping Method*                             | Status after Stopping | When Enabled  | Classification |
|------------------|--|--|-----------------------|---------------|----------------|
| Pn001<br>(2001h) | n.□□00<br>(default setting)                        | Dynamic brake                                      | Coasting              | After restart | Setup          |
|                  | n.□□01   |  |                       |               |                |
|                  | n.□□02   | Coasting   |                       |               |                |
|                  | n.□□1□   | Deceleration according to setting of Pn406 (2406h) | Zero clamp            |               |                |
|                  | n.□□2□   | Deceleration according to setting of Pn406 (2406h) | Coasting              |               |                |
|                  | n.□□3□   | Deceleration according to setting of Pn30A (230Ah) | Zero clamp            |               |                |
| n.□□4□           | Deceleration according to setting of Pn30A (230Ah) | Coasting   |                       |               |                |

\* You cannot decelerate a Servomotor to a stop during torque control. For torque control, the Servomotor will be stopped with the dynamic braking or coast to a stop (according to the setting of Pn001 = n.□□□X (Servo OFF or Alarm Group 1 Stopping Method)), and then the Servomotor will enter a coasting state.

Refer to the following section for information on stopping methods other than those for overtravel.

 6.12.1 Stopping Method for Servo OFF on page 6-37

## Stopping the Servomotor by Setting Emergency Stop Torque

To stop the Servomotor by setting emergency stop torque, set Pn406 (Emergency Stop Torque).

If Pn001 = n.□□X□ is set to 1 or 2, the Servomotor will be decelerated to a stop using the torque set in Pn406 as the maximum torque.

The default setting is 800%. This setting is large enough to allow you to operate the Servomotor at the maximum torque. However, the maximum emergency stop torque that you can actually use is the maximum torque of the Servomotor.

| Pn406<br>(2406h) | Emergency Stop Torque |              |                 |              | Speed          | Position |
|------------------|-----------------------|--------------|-----------------|--------------|----------------|----------|
|                  | Setting Range         | Setting Unit | Default Setting | When Enabled | Classification |          |
|                  | 0 to 800              | 1%*          | 800             | Immediately  | Setup          |          |

\* Set a percentage of the motor rated torque.

## Stopping the Servomotor by Setting the Deceleration Time

To specify the Servomotor deceleration time and use it to stop the Servomotor, set Pn30A (Deceleration Time for Servo OFF and Forced Stops).

| Pn30A<br>(230Ah) | Deceleration Time for Servo OFF and Forced Stops |              |                 |              | Speed          | Position |
|------------------|--|--------------|-----------------|--------------|----------------|----------|
|                  | Setting Range                                    | Setting Unit | Default Setting | When Enabled | Classification |          |
|                  | 0 to 10,000                                      | 1 ms         | 0               | Immediately  | Setup          |          |

If you set Pn30A to 0, the Servomotor will be stopped with a zero speed.

The deceleration time that you set in Pn30A is the time to decelerate the motor from the maximum motor speed.

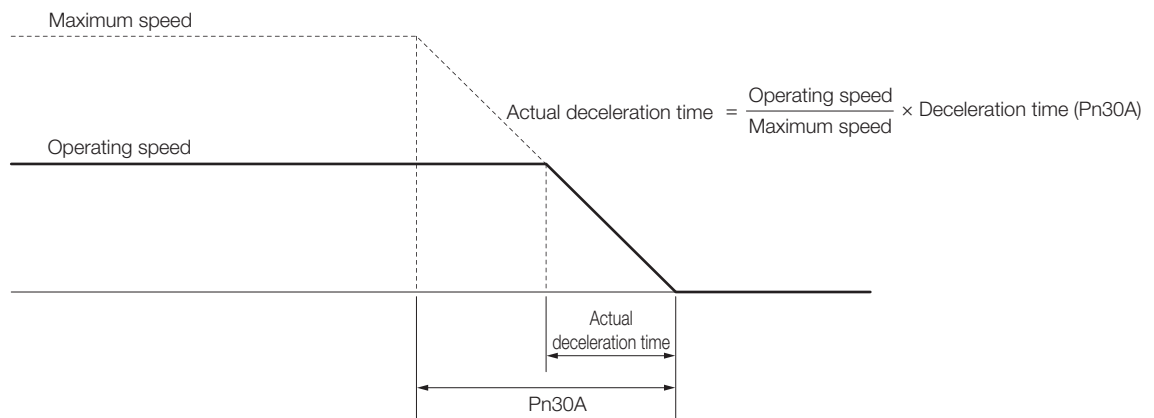

## 6.10.4 Overtravel Warnings

You can set the system to detect an A.9A0 warning (Overtravel) if overtravel occurs while the servo is ON. This allows the SERVOPACK to notify the host controller with a warning even when the overtravel signal is input only momentarily. An alarm occurs only if overtravel occurs while the servo is ON. An overtravel warning will not be detected when the servo is OFF, even if overtravel occurs.



Important

1. The occurrence of an A.9A0 warning will not stop the motor or have any effect on host controller motion operations. The next step (e.g., the next motion or command) can be executed even if an overtravel warning exists. However, depending on the processing specifications and programming for warnings in the host controller, operation may be affected when an overtravel warning occurs (e.g., motion may stop or not stop). Confirm the specifications and programming in the host controller.
2. When overtravel occurs, the SERVOPACK will perform stop processing for overtravel. Therefore, when an A.9A0 warning occurs, the Servomotor may not reach the target position specified by the host controller. Check the feedback position to make sure that the axis is stopped at a safe position.

The following parameter is set for this function.

| Parameter        |                             | Meaning                            | When Enabled | Classification |
|------------------|-----------------------------|------------------------------------|--------------|----------------|
| Pn00D<br>(200Dh) | n.0□□□<br>(default setting) | Do not detect overtravel warnings. | Immediately  | Setup          |
|                  | n.1□□□                      | Detect overtravel warnings.        |              |                |

A timing chart for warning detection is provided below.

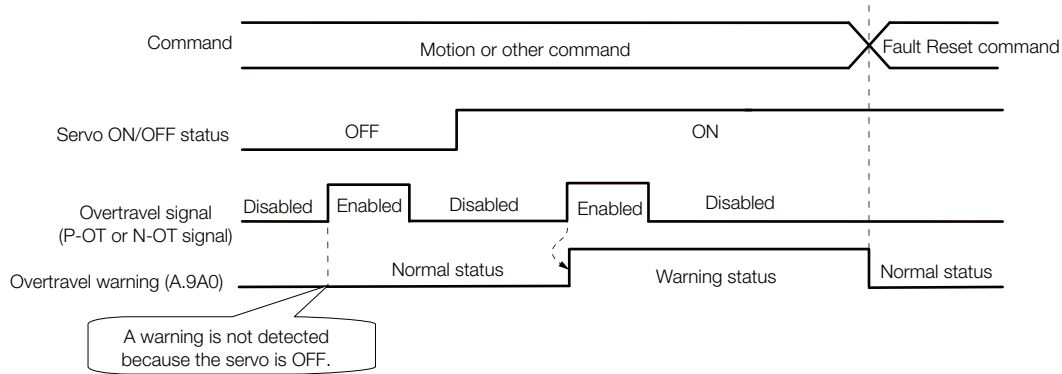

**Information**

1. Warnings are detected for overtravel in the same direction as the reference.
2. Warnings are not detected for overtravel in the opposite direction from the reference. Example: A warning will not be output for a forward reference even if the N-OT signal turns ON.
3. A warning can be detected in either the forward or reverse direction if there is no reference.
4. A warning will not be detected when the servo is turned ON even if overtravel status exists.
5. You can use the ALM\_CLR (Clear Alarms and Warnings) command to clear the warning regardless of the servo ON/OFF status and overtravel signal status.
6. If you clear the warning with the Fault Reset command during overtravel status, a warning will not be detected again until the overtravel status is left.
7. An overtravel warning will be detected even when the software limit has been detected.

## 6.10.5 Overtravel Release Method Selection

You can set Pn022 = n.□□□X (Overtravel Release Method Selection) to release overtravel. *Internal limit active* (bit 11) in *status word* changes to 1 during overtravel. The motor will not be driven if there is overtravel in the same direction as the reference.

| Parameter        | Meaning                     | When Enabled  | Classification |
|------------------|-----------------------------|---------------|----------------|
| Pn022<br>(2022h) | n.□□□0<br>(default setting) | After restart | Setup          |
|                  | n.□□□1                      |               |                |

\* Here, "separated" means a position that is further in the positive direction than the P-OT signal or a position that is further in the negative direction than the N-OT signal.

### When Pn022 Is Set to n.□□□0

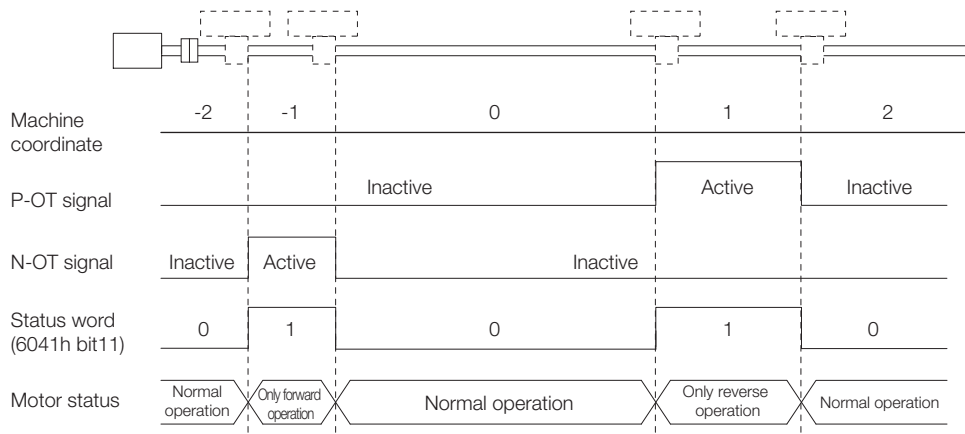

### When Pn022 Is Set to n.□□□1

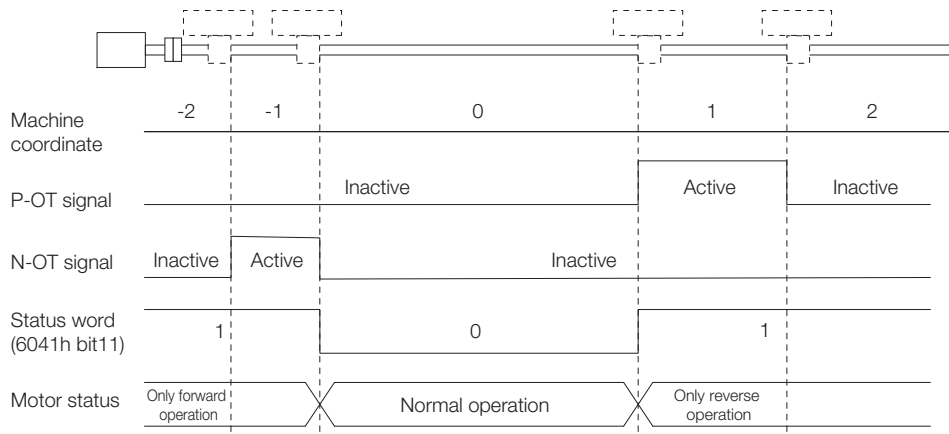

## 6.10.6 Overtravel Status

If an overtravel signal is input, the following SERVOPACK status will change to 1 and the Servomotor will be stopped according to the overtravel stopping method set in Pn001. When the overtravel signal is reset, the status changes to 0.

*Internal limit active* (bit 11) in *status word* (6041h)

*Negative limit switch* (bit 0) or *positive limit switch* (bit 1) in *digital inputs* (60FDh)

## 6.10.7 Overtravel Operation by Mode

| Operation Mode  | Operation   |
|---|---|
| Profile position mode   | <ul style="list-style-type: none"> <li>If an overtravel signal is input, the positioning operation to the current target position will be canceled and, after the motor stops, <i>target reached</i> in <i>status word</i> will be reset.</li> <li>A positioning operation (return operation) is started only when a movement reference to a target position in the opposite direction from the overtravel signal is specified in the current Position Actual Value (e.g., a negative movement reference if the P-OT signal is input).</li> </ul>         |
| Homing mode   | <ul style="list-style-type: none"> <li>For Homing Method 1, 11, 12, 13, 14, 28, or 34:<br/>If the P-OT signal is input, <i>homing error</i> (bit 13) in <i>status word</i> (6041h) changes to 1 and the homing operation is canceled.</li> <li>For Homing Method 2, 7, 8, 9, 10, 24, or 33:<br/>If the N-OT signal is input, <i>homing error</i> (bit 13) in <i>status word</i> (6041h) changes to 1 and the homing operation is canceled.</li> </ul>   |
| Interpolated position mode,<br>Cyclic synchronous position mode | <ul style="list-style-type: none"> <li>If an overtravel signal is input, the positioning operation to the current target position will be canceled and, after the motor stops, <i>target reached</i> in <i>status word</i> will be reset.</li> <li>A positioning operation (return operation) is started only when a movement reference to a target position in the opposite direction from the overtravel signal is specified in the current <i>position actual value</i> (e.g., a negative movement references if the P-OT signal is input).</li> </ul> |
| Profile velocity mode, Cyclic synchronous velocity mode         | <ul style="list-style-type: none"> <li>During overtravel, the motor is operated only when a speed in the direction opposite from the overtravel signal is specified (e.g., a negative target speed when the P-OT signal is input).</li> </ul>   |
| Profile torque mode, Cyclic synchronous torque mode             | <ul style="list-style-type: none"> <li>During overtravel, torque is applied only when a torque in the direction opposite from the overtravel signal is specified (e.g., a negative torque when the P-OT signal is input).</li> </ul>  |



# 6.11 Holding Brake

A holding brake is used to hold the position of the moving part of the machine when the SERVOPACK is turned OFF so that moving part does not move due to gravity or an external force. You can use the brake that is built into a Servomotor with a Brake, or you can provide one on the machine.

The holding brake is used in the following cases.

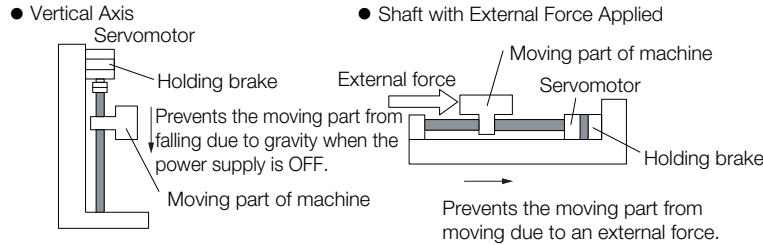

**Important** The brake built into a Servomotor with a Brake is a de-energization brake. It is used only to hold the Servomotor and cannot be used for braking. Use the holding brake only to hold a Servomotor that is already stopped.

## 6.11.1 Brake Operating Sequence

You must consider the time required to release the brake and the time required to brake to determine the brake operation timing, as described below.

**Term** **Time Required to Release Brake**  
The time from when the /BK (Brake) signal is turned ON until the brake is actually released.

**Time Required to Brake**  
The time from when the /BK (Brake) signal is turned OFF until the brake actually operates.

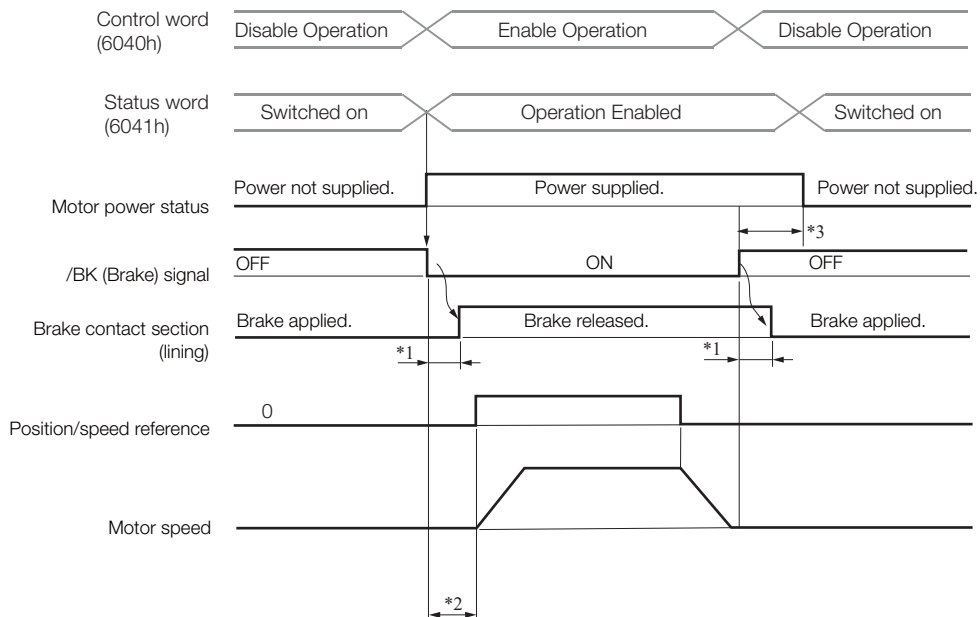

\*1. Rotary Servomotors: The brake delay times for Servomotors with Holding Brakes are given in the following table. The operation delay times in the following table are examples for when the power supply is switched on the DC side. You must evaluate the actual brake delay times on the actual equipment before using the application.

Basic Functions That Require Setting before Operation

| Model           | Voltage | Time Required to Release Brake [ms] | Time Required to Brake [ms] |
|-----------------|---------|-------------------------------------|-----------------------------|
| SGM7J-02, -04   | 24 VDC  | 60                                  | 100                         |
| SGM7J-08, -15   |         | 80                                  |                             |
| SGM7A-02, -04   |         | 60                                  |                             |
| SGM7A-08, -10   |         | 80                                  |                             |
| SGM7A-15 to -25 |         | 170                                 | 80                          |
| SGM7A-30 to -50 |         | 100                                 |                             |
| SGM7G-05 to -20 |         | 100                                 |                             |
| SGM7G-30, -44   |         | 170                                 |                             |

Linear Servomotors: The brake delay times depend on the brake that you use. Set the parameters related to /BK signal output timing according to the delay times for the brake that you will actually use.

- \*2. Before you output a reference from the host controller to the SERVOPACK, wait for at least 50 ms plus the time required to release the brake after you send the Servo ON command (Enable Operation command).
- \*3. Use the following parameters to set the timing of when the brake will operate and when the servo will be turned OFF.
  - Rotary Servomotors: Pn506 (Brake Reference-Servo OFF Delay Time), Pn507 (Brake Reference Output Speed Level), and Pn508 (Servo OFF-Brake Reference Waiting Time)
  - Linear Servomotors: Pn506 (Brake Reference-Servo OFF Delay Time), Pn508 (Servo OFF-Brake Reference Waiting Time), and Pn583 (Brake Reference Output Speed Level)

Note: The brake operation delay time on SERVOPACKs with built-in Servomotor brake control is somewhat longer than the time required on SERVOPACKs without built-in Servomotor brake control. Consider the brake operation delay time when you design the system.

## Connection Examples

Refer to the following section for information on brake wiring.

 4.4.4 Wiring the SERVOPACK to the Holding Brake on page 4-33

## 6.11.2 /BK (Brake) Signal

The following settings are for the output signal that controls the brake. You can change the connector pin that is allocated. For details, refer to *Allocating the /BK (Brake) Signal*. The /BK signal is turned OFF (to operate the brake) when the servo is turned OFF or when an alarm is detected. You can adjust the timing of brake operation (i.e., the timing of turning OFF the /BK signal) with the servo OFF delay time (Pn506).

| Type   | Signal | Connector Pin No.         | Signal Status | Meaning              |
|--------|--------|---------------------------|---------------|----------------------|
| Output | /BK    | Axis A: CN1-1 and CN1-2   | ON (closed)   | Releases the brake.  |
|        |        | Axis B: CN1-23 and CN1-24 | OFF (open)    | Activates the brake. |

**Information** The /BK signal will remain ON during overtravel. The brake will not be applied.

## Allocating the /BK (Brake) Signal

Set the allocation for the /BK signal in Pn50F = n.□X□□ (/BK (Brake Output) Signal Allocation).

- Axis A

| Parameter     | Connector Pin No.        |        | Meaning | When Enabled  | Classification |
|---------------|--------------------------|--------|---------|---------------|----------------|
|               | + Pin                    | - Pin  |         |               |                |
| Pn50F (250Fh) | n.□0□□                   | -      | -       | After restart | Setup          |
|               | n.□1□□ (default setting) | CN1-1  | CN1-2   |               |                |
|               | n.□2□□                   | CN1-25 | CN1-26  |               |                |

## • Axis B

| Parameter        | Connector Pin No.           |        | Meaning | When Enabled                                     | Classification |       |
|------------------|-----------------------------|--------|---------|--|----------------|-------|
|                  | + Pin                       | - Pin  |         |  |                |       |
| Pn50F<br>(250Fh) | n.□0□□                      | –      | –       | The /BK signal is not used.                      | After restart  | Setup |
|                  | n.□1□□<br>(default setting) | CN1-23 | CN1-24  | The /BK signal is output from CN1-23 and CN1-24. |                |       |
|                  | n.□2□□                      | CN1-27 | CN1-28  | The /BK signal is output from CN1-27 and CN1-28. |                |       |



Important

If you allocate more than one signal to the same output connector pin, a logical OR of the signals is output. Allocate the /BK signal to its own output connector pin, i.e., do not use the same output terminal for another signal.

For example, never allocate the /TGON (Rotation Detection) signal and /BK signal to the same output connector pin. If you did so, the /TGON signal would be turned ON by the falling speed on a vertical axis, and the brake would not operate.

## 6.11.3 Output Timing of /BK (Brake) Signal When the Servomotor Is Stopped

When the Servomotor is stopped, the /BK signal turns OFF as soon as the servo OFF (Disable Operation) command is received. Use the servo OFF delay time (Pn506) to change the timing to turn OFF power supply to the motor after the Disable Operation command is input.

| Pn506<br>(2506h) | Brake Reference-Servo OFF Delay Time |              |                 |              | Speed          | Position | Torque |
|------------------|--------------------------------------|--------------|-----------------|--------------|----------------|----------|--------|
|                  | Setting Range                        | Setting Unit | Default Setting | When Enabled | Classification |          |        |
|                  | 0 to 50                              | 10 ms        | 0*              | Immediately  | Setup          |          |        |

\* The default setting for axis A is 32 for a SERVOPACK with built-in Servomotor brake control.

- When the Servomotor is used to control a vertical axis, the machine moving part may move slightly due to gravity or an external force. You can eliminate this slight motion by setting the servo OFF delay time (Pn506) so that power supply to the motor is stopped after the brake is applied.
- This parameter sets the timing of stopping power supply to the Servomotor while the Servomotor is stopped.

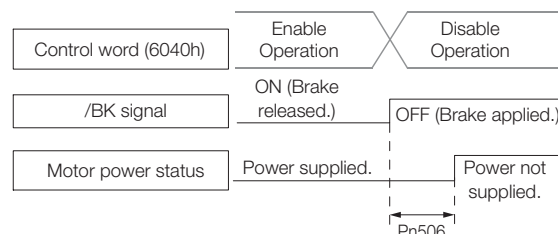

Important

Power supply to the Servomotor will be stopped immediately when an alarm occurs, regardless of the setting of this parameter. The machine moving part may move due to gravity or an external force before the brake is applied.

## 6.11.4 Output Timing of /BK (Brake) Signal When the Servomotor Is Operating

If an alarm occurs while the Servomotor is operating, the Servomotor will start stopping and the /BK signal will be turned OFF. You can adjust the timing of /BK signal output by setting the brake reference output speed level (Rotary Servomotors: Pn507, Linear Servomotors: Pn583) and the Servo OFF-Brake Command Waiting Time (Pn508).

Note: If zero-speed stopping is set as the stopping method for alarms, the setting of Pn506 (Brake Reference-Servo OFF Delay Time) is used after the motor stops.

• Rotary Servomotors

| Pn507<br>(2507h) | Brake Reference Output Speed Level   |                     |                 | Speed        | Position       | Torque |
|------------------|--------------------------------------|---------------------|-----------------|--------------|----------------|--------|
|                  | Setting Range                        | Setting Unit        | Default Setting | When Enabled | Classification |        |
|                  | 0 to 10,000                          | 1 min <sup>-1</sup> | 100             | Immediately  | Setup          |        |
| Pn508<br>(2508h) | Servo OFF-Brake Command Waiting Time |                     |                 | Speed        | Position       | Torque |
|                  | Setting Range                        | Setting Unit        | Default Setting | When Enabled | Classification |        |
|                  | 10 to 100                            | 10 ms               | 50              | Immediately  | Setup          |        |

• Linear Servomotors

| Pn583<br>(2583h) | Brake Reference Output Speed Level   |              |                 | Speed        | Position       | Force |
|------------------|--------------------------------------|--------------|-----------------|--------------|----------------|-------|
|                  | Setting Range                        | Setting Unit | Default Setting | When Enabled | Classification |       |
|                  | 0 to 10,000                          | 1 mm/s       | 10              | Immediately  | Setup          |       |
| Pn508<br>(2508h) | Servo OFF-Brake Command Waiting Time |              |                 | Speed        | Position       | Force |
|                  | Setting Range                        | Setting Unit | Default Setting | When Enabled | Classification |       |
|                  | 10 to 100                            | 10 ms        | 50              | Immediately  | Setup          |       |

The brake operates when either of the following conditions is satisfied:

- When the Motor Speed Goes below the Level Set in Pn507 for a Rotary Servomotor or in Pn583 for a Linear Servomotor after the Power Supply to the Motor Is Stopped

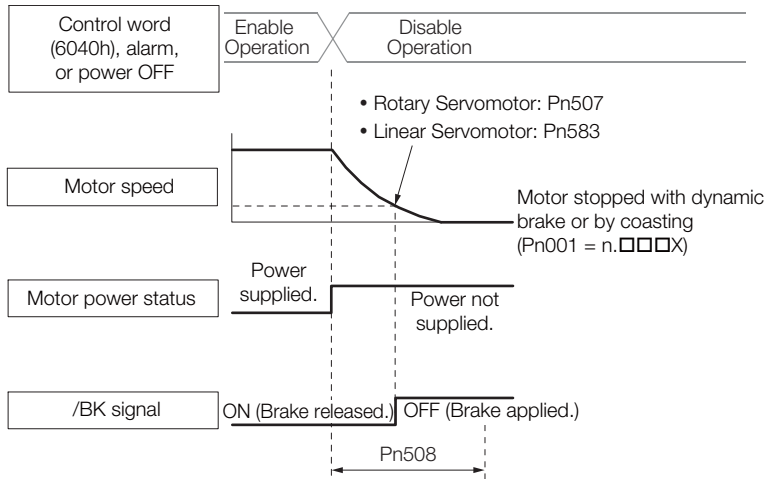

- When the Time Set In Pn508 Elapses after the Power Supply to the Motor Is Stopped

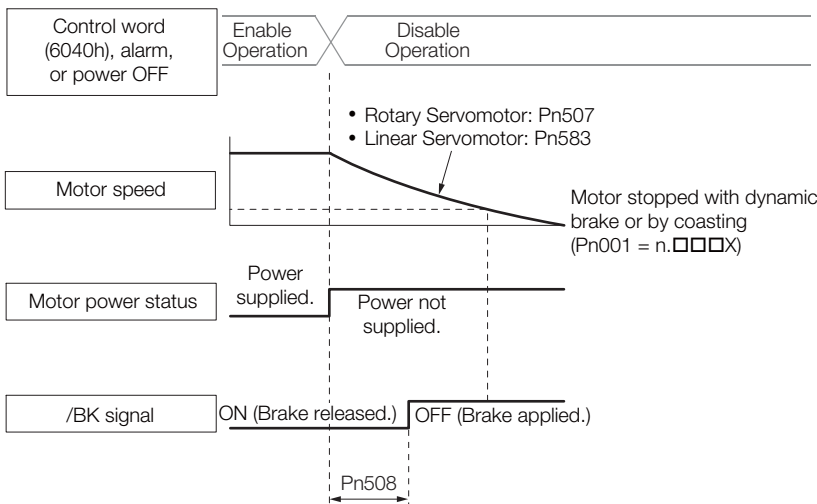

**Important** The Servomotor will be limited to its maximum speed even if the brake reference output speed level (Rotary Servomotor: Pn507, Linear Servomotor: Pn583) is higher than the maximum speed.

## 6.11.5 Built-in Brake Relay Usage Selection

SERVOPACKs with built-in Servomotor brake control contain a brake relay.

Set Pn023 = n.□□X (Built-in Brake Relay Usage Selection) to specify whether to use the built-in brake relay. This function is supported only for axis A.

| Parameter                  |                             | Description                          | When Enabled  | Classification |
|----------------------------|-----------------------------|--------------------------------------|---------------|----------------|
| Pn023<br>(2023h)<br>Common | n.□□□0<br>(default setting) | Use the built-in brake relay.        | After restart | Setup          |
|                            | n.□□□1                      | Do not use the built-in brake relay. |               |                |

You can use Pn023 = n.□□X□ (Built-in Brake Relay Life Alarm Enable Selection) to select whether to detect or not detect the built-in brake relay life alarm (alarm code: 232h). Refer to the following section for details.

 10.4.3 Preventative Maintenance on page 10-15

## 6.12 Motor Stopping Methods for Servo OFF and Alarms

You can use the following methods to stop the Servomotor when the servo is turned OFF or an alarm occurs.

There are the following four stopping methods.

| Motor Stopping Method                  | Meaning  |
|--|--|
| Stopping by Applying the Dynamic Brake | The electric circuits are internally connected to stop the Servomotor quickly. |
| Coasting to a Stop                     | The motor stops naturally due to friction during operation.                    |
| Zero-speed Stopping                    | The speed reference is set to 0 to stop the Servomotor quickly.                |
| Decelerating to a Stop                 | Emergency stop torque is used to decelerate the motor to a stop.               |

There are the following three conditions after stopping.

| Status after Stopping | Meaning  |
|-----------------------|--|
| Dynamic Brake Applied | The electric circuits are internally connected to hold the Servomotor.   |
| Coasting              | The SERVOPACK does not control the Servomotor. (The machine will move in response to a force from the load.)                     |
| Zero Clamping         | A position loop is created and the Servomotor remains stopped at a position reference of 0. (The current stop position is held.) |



Important

- The dynamic brake is used for emergency stops. The dynamic brake circuit will operate frequently if the power supply is turned ON and OFF or the servo is turned ON and OFF while a reference input is applied to start and stop the Servomotor. This may result in deterioration of the internal elements in the SERVOPACK. Use speed input references or position references to start and stop the Servomotor.
- If you turn OFF the main circuit power supply or control power supply during operation before you turn OFF the servo, the Servomotor will stop with the dynamic brake. You cannot change this by setting a parameter.
- To minimize the coasting distance of the Servomotor to come to a stop when an alarm occurs, zero-speed stopping is the default method for alarms to which it is applicable. However, depending on the application, stopping with the dynamic brake may be more suitable than zero-speed stopping.  
For example, when coupling two shafts (twin-drive operation), machine damage may occur if a zero-speed stopping alarm occurs for one of the coupled shafts and the other shaft stops with a dynamic brake. In such cases, change the stopping method to the dynamic brake.

## 6.12.1 Stopping Method for Servo OFF

Set the stopping method for when the servo is turned OFF in Pn001 = n.□□□X (Servo OFF or Alarm Group 1 Stopping Method).

To use the dynamic brake to stop the motor, set Pn001 to n.□□□0 or n.□□□1.

If you do not connect an external dynamic brake, set Pn001 to n.□□□2 (Coast the motor to a stop without the dynamic brake).

| Parameter        |                             | Servomotor Stopping Method | Status after Servomotor Stops | When Enabled  | Classification |
|------------------|-----------------------------|----------------------------|-------------------------------|---------------|----------------|
| Pn001<br>(2001h) | n.□□□0<br>(default setting) | Dynamic brake              | Dynamic brake                 | After restart | Setup          |
|                  | n.□□□1                      |                            | Coasting                      |               |                |
|                  | n.□□□2                      | Coasting                   | Coasting                      |               |                |

Note: If Pn001 is set to n.□□□0 (Stop the motor by applying the dynamic brake) and the Servomotor is stopped or operates at a low speed, braking force may not be generated, just like it is not generated for coasting to a stop.

## 6.12.2 Servomotor Stopping Method for Alarms

There are two types of alarms, group 1 (Gr. 1) alarms and group 2 (Gr. 2) alarms. A different parameter is used to set the stopping method for alarms for each alarm type.

Refer to the following section to see which alarms are in group 1 and which are in group 2.

 15.2.1 List of Alarms on page 15-5

### Motor Stopping Method for Group 1 Alarms

When a group 1 alarm occurs, the Servomotor will stop according to the setting of Pn001 = n.□□□X. The default setting is to stop by applying the dynamic brake.

Refer to the following section for details.

 6.12.1 Stopping Method for Servo OFF on page 6-37

### Motor Stopping Method for Group 2 Alarms

When a group 2 alarm occurs, the Servomotor will stop according to the settings of the following three parameters. The default setting is for zero clamping.

- Pn001 = n.□□□X (Servo OFF or Alarm Group 1 Stopping Method)
- Pn00A = n.□□□X (Motor Stopping Method for Group 2 Alarms)
- Pn00B = n.□□X□ (Motor Stopping Method for Group 2 Alarms)

However, during torque control, the group 1 stopping method is always used.



If you set Pn00B to n.□□1□ (Apply dynamic brake or coast Servomotor to a stop), you can use the same stopping method as group 1. If you are coordinating a number of Servomotors, you can use this stopping method to prevent machine damage that may result because of differences in the stopping method.

The following table shows the combinations of the parameter settings and the resulting stopping methods.

6.12 Motor Stopping Methods for Servo OFF and Alarms

6.12.2 Servomotor Stopping Method for Alarms

| Parameter                |                          |                          | Servomotor Stopping Method                                  | Status after Servomotor Stops   | When Enabled  | Classification |
|--------------------------|--------------------------|--------------------------|---|---|---------------|----------------|
| Pn00B (200Bh)            | Pn00A (200Ah)            | Pn001 (2001h)            |   |   |               |                |
| n.□□0□ (default setting) | -                        | n.□□□0 (default setting) | Zero-speed stopping   | Dynamic brake   | After restart | Setup          |
|                          |                          | n.□□□1                   |   | Coasting  |               |                |
|                          |                          | n.□□□2                   |   |   |               |                |
| n.□□1□                   | -                        | n.□□□0 (default setting) | Dynamic brake   | Dynamic brake   |               |                |
|                          |                          | n.□□□1                   | Coasting  | Coasting  |               |                |
|                          |                          | n.□□□2                   | Coasting  |   |               |                |
| n.□□2□                   | n.□□□0 (default setting) | n.□□□0 (default setting) | Dynamic brake   | Dynamic brake   |               |                |
|                          |                          | n.□□□1                   | Coasting  | Coasting  |               |                |
|                          |                          | n.□□□2                   |   |   |               |                |
|                          | n.□□□1                   | n.□□□0 (default setting) |   | Motor is decelerated using the torque set in Pn406 (2406h) as the maximum torque. |               |                |
|                          |                          | n.□□□1                   | Coasting  |   |               |                |
|                          |                          | n.□□□2                   |   |   |               |                |
|                          | n.□□□2                   | n.□□□0 (default setting) | Coasting  |   | Coasting      |                |
|                          |                          | n.□□□1                   |   |   |               |                |
|                          |                          | n.□□□2                   |   |   |               |                |
|                          | n.□□□3                   | n.□□□0 (default setting) | Motor is decelerated according to setting of Pn30A (230Ah). | Dynamic brake   |               |                |
|                          |                          | n.□□□1                   |   | Coasting  |               |                |
|                          |                          | n.□□□2                   |   |   |               |                |
| n.□□□4                   | n.□□□0 (default setting) | Coasting                 |   | Coasting  |               |                |
|                          | n.□□□1                   |                          |   |   |               |                |
|                          | n.□□□2                   |                          |   |   |               |                |

- Note: 1. The setting of Pn00A is ignored if Pn001 is set to n.□□0□ or n.□□1□.  
 2. The setting of Pn00A = n.□□□X is enabled for position control and speed control. During torque control, the setting of Pn00A = n.□□□X will be ignored and only the setting of Pn001 = n.□□□X will be used.  
 3. Refer to the following section for details on Pn406 (Emergency Stop Torque).  
 *Stopping the Servomotor by Setting Emergency Stop Torque on page 6-27*  
 4. Refer to the following section for details on Pn30A (Deceleration Time for Servo OFF and Forced Stops).  
 *Stopping the Servomotor by Setting the Deceleration Time on page 6-27*



## 6.13 Motor Overload Detection Level

The motor overload detection level is the threshold used to detect overload alarms and overload warnings when the Servomotor is subjected to a continuous load that exceeds the Servomotor ratings.

It is designed to prevent Servomotor overheating.

You can change the detection timing for A.910 warnings (Overload) and A.720 alarms (Continuous Overload). You cannot change the detection level for A.710 alarms (Instantaneous Overload).

### 6.13.1 Detection Timing for Overload Warnings (A.910)

With the default setting for overload warnings, an overload warning is detected in 20% of the time required to detect an overload alarm. You can change the time required to detect an overload warning by changing the setting of the overload warning level (Pn52B). You can increase safety by using overload warning detection as an overload protection function matched to the system.

The following graph shows an example of the detection of overload warnings when the overload warning level (Pn52B) is changed from 20% to 50%. An overload warning is detected in half of the time required to detect an overload alarm.

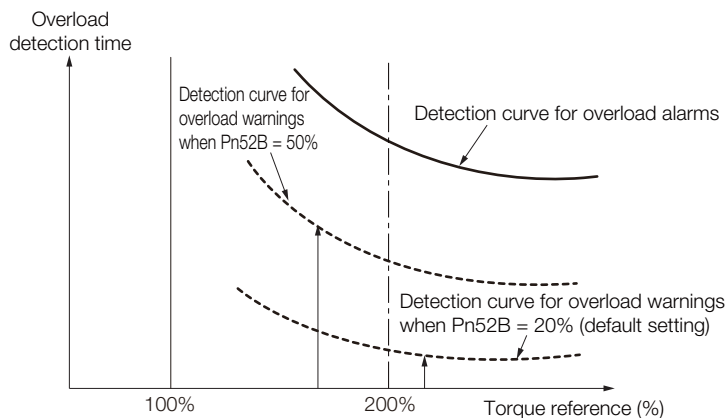

| Pn52B<br>(252Bh) | Overload Warning Level |              |                 | Speed        | Position       | Torque |
|------------------|------------------------|--------------|-----------------|--------------|----------------|--------|
|                  | Setting Range          | Setting Unit | Default Setting | When Enabled | Classification |        |
|                  | 1 to 100               | 1%           | 20              | Immediately  | Setup          |        |

## 6.13.2 Detection Timing for Overload Alarms (A.720)

If Servomotor heat dissipation is insufficient (e.g., if the heat sink is too small), you can lower the overload alarm detection level to help prevent overheating.

To reduce the overload alarm detection level, change the setting of Pn52C (Base Current Derating at Motor Overload Detection).

| Pn52C<br>(252Ch) | Base Current Derating at Motor Overload Detection |              |                 | Speed         | Position       | Torque |
|------------------|---|--------------|-----------------|---------------|----------------|--------|
|                  | Setting Range                                     | Setting Unit | Default Setting | When Enabled  | Classification |        |
|                  | 10 to 100   | 1%           | 100             | After restart | Setup          |        |

An A.720 alarm (Continuous Overload) can be detected earlier to protect the Servomotor from overloading.

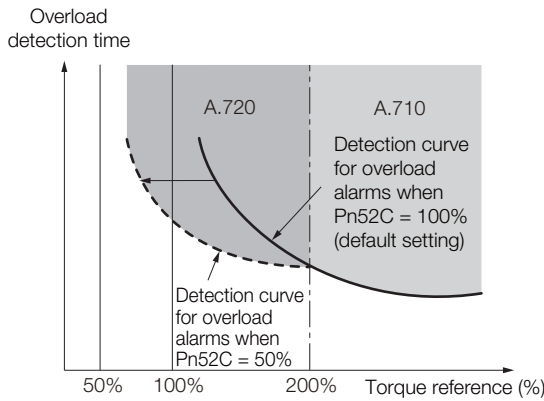

Note: The gray areas in the above graph show where A.710 and A.720 alarms occur.

Refer to the relevant manual given below for a diagram that shows the relationships between the motor heat dissipation conditions (heat sink size, surrounding air temperature, and derating). You can protect the motor from overloads more effectively by setting this derating value in Pn52C.

📖  $\Sigma$ -7-Series Rotary Servomotor with 400 V-Input Power Product Manual (Manual No.: SIEP S800001 86)

📖  $\Sigma$ -7-Series Linear Servomotor with 400 V-Input Power Product Manual (Manual No.: SIEP S800001 81)

## 6.14 Setting Unit Systems

You can set the SERVOPACK reference units with EtherCAT (CoE) communications. You can set the following four reference units with EtherCAT communications.

- Position reference unit
- Speed reference unit
- Acceleration reference unit
- Torque reference unit

The setting procedures are given below.

### 6.14.1 Setting the Position Reference Unit

Set the position reference unit in *position user unit* (2701h). The position reference unit setting will be used for the electronic gear ratio setting.



Important

- For a Rotary Servomotor with an encoder resolution of 24 bits (16,777,216), Pn20E (Electronic Gear Ratio (Numerator)) is automatically set to 16 and Pn210 (Electronic Gear Ratio (Denominator)) is automatically set to 1. Therefore, the encoder resolution will be equivalent to 20 bits (1,048,576). Consider this when you set the position reference unit in *position user unit* (2701h).
- Set the position reference unit within the following range.  
 $1/4,096 < \text{Numerator/Denominator} < 65,536$   
 If the setting range is exceeded, an A.A20 alarm (Parameter Setting Error) will occur.

| Index | Subindex | Name              | Data Type | Access | PDO Mappings | Value                              | Saving to EEPROM |
|-------|----------|-------------------|-----------|--------|--------------|------------------------------------|------------------|
| 2701h | 0        | Number of entries | USINT     | RO     | No           | 2                                  | No               |
|       | 1        | Numerator         | UDINT     | RW     | No           | 1 to 1,073,741,823<br>(default: 1) | Yes              |
|       | 2        | Denominator       | UDINT     | RW     | No           | 1 to 1,073,741,823<br>(default: 1) | Yes              |

Note: Refer to the following section for information on *position user unit* (2701h).

*Position User Unit (A: 2701h, B: 2F01h)* on page 14-22

The minimum unit of the position data that is used to move a load is called the reference unit. The reference unit is used to give travel amounts, not in pulses, but rather in distances or other physical units (such as  $\mu\text{m}$  or  $^\circ$ ) that are easier to understand.

The electronic gear is used to convert the travel distances that are specified in reference units to pulses, which are required for actual movements.

With the electronic gear, one reference unit is equal to the workpiece travel distance per reference pulse input to the SERVOPACK. In other words, if you use the SERVOPACK's electronic gear, pulses can be read as reference units.

The difference between using and not using the electronic gear is shown below.

#### • Rotary Servomotors

In this example, the following machine configuration is used to move the workpiece 10 mm.

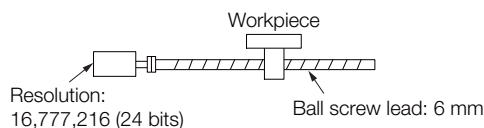

When the Electronic Gear Is Not Used

To move a workpiece 10 mm:  
 ① Calculate the number of revolutions.  
 The motor will move 6 mm for each revolution, so 10/6 revolutions are required to move 10 mm.  
 ② Calculate the required number of reference pulses.  
 One revolution is 1,048,576 pulses, therefore  $10/6 \times 1,048,576 = 1,747,626.66$  pulses.  
 ③ Input 1,747,627 pulses as the reference.

Calculating the number of reference pulses for each reference is troublesome.

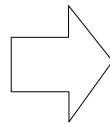

When the Electronic Gear Is Used

If you use reference units to move the workpiece when one reference unit is set to 1 μm, the travel distance is 1 μm per pulse.  
 To move the workpiece 10 mm (10,000 μm),  $10,000 \div 1 = 10,000$  pulses, so 10,000 pulses would be input.

Calculating the number of reference pulses for each reference is not necessary.

• Linear Servomotors

In this example, the following machine configuration is used to move the load 10 mm. We'll assume that the resolution of the Serial Converter Unit is 256 and that the linear encoder pitch is 20 μm.

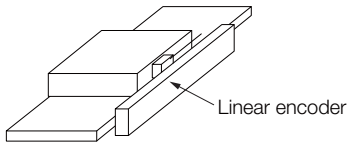

When the Electronic Gear Is Not Used

To move the load 10 mm:  
 $10 \times 1000 \div 20 \times 256 = 128,000$  pulses, so 128,000 pulses are input as the reference.

Calculating the number of reference pulses for each reference is troublesome.

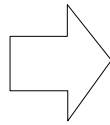

When the Electronic Gear Is Used

To use reference units to move the load 10 mm:  
 If we set the reference unit to 1 μm, the travel distance is 1 μm per pulse. To move the load 10 mm (10,000 μm),  $10,000/1 = 10,000$  pulses, so 10,000 pulses would be input as the reference.

Calculating the number of reference pulses for each reference is not necessary.

## Calculating the Settings for the Electronic Gear Ratio

### ◆ Rotary Servomotors

If the gear ratio between the Servomotor shaft and the load is given as n/m, where n is the number of load rotations for m Servomotor shaft rotations, the settings for the electronic gear ratio can be calculated as follows:

$$\text{Electronic gear ratio } \frac{B}{A} = \frac{Pn20E}{Pn210} = \frac{\text{Encoder resolution}}{\text{Travel distance per load shaft revolution (reference units)}} \times \frac{m}{n}$$

**Information** For a Rotary Servomotor with an encoder resolution of 24 bits (16,777,216), Pn20E (Electronic Gear Ratio (Numerator)) is automatically set to 16 and Pn210 (Electronic Gear Ratio (Denominator)) is automatically set to 1. Therefore, the encoder resolution will be equivalent to 20 bits (1,048,576). Consider this when you set the position reference unit in *position user unit* (2701h).

### ■ Encoder Resolution

You can check the encoder resolution in the Servomotor model number.

SGM7J, SGM7A,  
 or SGM7G - □□□□□□□□

| Code | Specification                     | Encoder Resolution |
|------|-----------------------------------|--------------------|
| 7    | 24-bit multiturn absolute encoder | 16,777,216         |
| F    | 24-bit incremental encoder        | 16,777,216         |

## ◆ Linear Servomotors

You can calculate the settings for the electronic gear ratio with the following equation:

When Not Using a Serial Converter Unit

Use the following formula if the linear encoder and SERVOPACK are connected directly or if a linear encoder that does not require a Serial Converter Unit is used.

$$\text{Electronic gear ratio } \frac{B}{A} = \frac{\text{Numerator}}{\text{Denominator}} = \frac{\text{Travel distance per reference unit (reference units)} \times \text{Linear encoder resolution}}{\text{Linear encoder pitch (the value from the following table)}}$$

When Using a Serial Converter Unit

$$\text{Electronic gear ratio } \frac{B}{A} = \frac{\text{Numerator}}{\text{Denominator}} = \frac{\text{Travel distance per reference unit (reference units)} \times \text{Resolution of the Serial Converter Unit}}{\text{Linear encoder pitch (setting of Pn282)}}$$

## ■ Feedback Resolution of Linear Encoder

The linear encoder pitches and resolutions are given in the following table.

Calculate the electronic gear ratio using the values in the following table.

| Type of Linear Encoder | Manufacturer                   | Linear Encoder Model           | Linear Encoder Pitch [μm] <sup>*1</sup> | Relay Device Model between SERVOPACK and Linear Encoder | Resolution                     | Resolution |
|------------------------|--------------------------------|--------------------------------|---|---|--------------------------------|------------|
| Incremental            | Dr. JOHANNES HEIDENHAIN GmbH   | LIDA48□                        | 20                                      | JZDP-H003-□□□□-E <sup>*2</sup>                          | 256                            | 0.078 μm   |
|                        |                                | LIF48□                         | 4                                       | JZDP-H003-□□□□-E <sup>*2</sup>                          | 4,096                          | 0.0049 μm  |
|                        |                                |                                |   | JZDP-J003-□□□□-E <sup>*2</sup>                          | 256                            | 0.016 μm   |
|                        |                                | Renishaw PLC                   | RGH22B                                  | 20  | JZDP-H005-□□□□-E <sup>*2</sup> | 4,096      |
|                        | TONIC series (Ti0000A00V only) |                                | 20                                      | JZDP-H005-□□□□-E <sup>*2</sup>                          | 256                            | 0.078 μm   |
|                        |                                | JZDP-J005-□□□□-E <sup>*2</sup> |   | 4,096   | 0.0049 μm                      |            |
|                        | Magnescale Co., Ltd.           | SR75-□□□□□LF                   | 80                                      | –   | 8,192                          | 0.0098 μm  |
|                        |                                | SR75-□□□□□MF                   | 80                                      | –   | 1,024                          | 0.078 μm   |
|                        |                                | SR85-□□□□□LF                   | 80                                      | –   | 8,192                          | 0.0098 μm  |
|                        |                                | SR85-□□□□□MF                   | 80                                      | –   | 1,024                          | 0.078 μm   |
|                        |                                | SL700, SL710, SL720, SL730     | 800                                     | PL101-RY <sup>*3</sup>                                  | 8,192                          | 0.0977 μm  |
|                        |                                |                                |   | MJ620-T13 <sup>*4</sup>                                 |                                |            |
|                        | SQ10                           | 400                            | MQ10-FLA <sup>*4</sup>                  | 8,192   | 0.0488 μm                      |            |
|                        |                                |                                | MQ10-GLA <sup>*4</sup>                  |   |                                |            |
| Canon Precision Inc.   | PH03-36110                     | 128                            | –                                       | 2,048   | 0.0625 μm                      |            |
|                        | PH03-36120                     | 128                            | –                                       | 2,048   | 0.0625 μm                      |            |
| Absolute               | Dr. JOHANNES HEIDENHAIN GmbH   | LIC4100 Series <sup>*5</sup>   | 20.48                                   | EIB3391Y <sup>*6</sup>                                  | 4,096                          | 0.005 μm   |
|                        |                                | LIC2100 Series <sup>*5</sup>   | 204.8                                   | EIB3391Y <sup>*6</sup>                                  | 4,096                          | 0.05 μm    |
|                        |                                |                                |   | EIB3391Y <sup>*6</sup>                                  | 4,096                          | 0.1 μm     |
|                        |                                | LIC4190 Series                 | 40.96                                   | –   | 4,096                          | 0.01 μm    |
|                        |                                |                                |   | 20.48   | –                              | 4,096      |
|                        |                                | LIC3190 Series                 | 4.096                                   | –   | 4,096                          | 0.001 μm   |
|                        |                                |                                |   | 40.96   | –                              | 4,096      |
|                        |                                | LIC2190 Series                 | 409.6                                   | –   | 4,096                          | 0.1 μm     |
|                        |                                |                                |   | 204.8   | –                              | 4,096      |
|                        |                                | LC115                          | 40.96                                   | EIB3391Y <sup>*6</sup>                                  | 4,096                          | 0.01 μm    |
| LC415                  | 40.96                          | EIB3391Y <sup>*6</sup>         | 4,096                                   | 0.01 μm   |                                |            |

Continued on next page.

6.14 Setting Unit Systems

6.14.1 Setting the Position Reference Unit

Continued from previous page.

| Type of Linear Encoder | Manufacturer              | Linear Encoder Model | Linear Encoder Pitch [μm]*1 | Relay Device Model between SERVOPACK and Linear Encoder | Resolution | Resolution |
|------------------------|---------------------------|----------------------|-----------------------------|---|------------|------------|
| Absolute               | RSF Elektronik GmbH       | MC15Y Series         | 409.6                       | –   | 4,096      | 0.1 μm     |
|                        |                           |                      | 204.8                       | –   | 4,096      | 0.05 μm    |
|                        | Mitutoyo Corporation      | ST781A/ST781AL       | 256                         | –   | 512        | 0.5 μm     |
|                        |                           |                      | 256                         | –   | 512        | 0.5 μm     |
|                        |                           |                      | 51.2                        | –   | 512        | 0.1 μm     |
|                        |                           |                      | 51.2                        | –   | 512        | 0.1 μm     |
|                        |                           |                      | 51.2                        | –   | 512        | 0.1 μm     |
|                        |                           |                      | 25.6                        | –   | 512        | 0.05 μm    |
|                        |                           |                      | 5.12                        | –   | 512        | 0.01 μm    |
|                        | Renishaw PLC              | EL36Y□□050F□□□       | 12.8                        | –   | 256        | 0.05 μm    |
|                        |                           |                      | 25.6                        | –   | 256        | 0.1 μm     |
|                        |                           |                      | 128                         | –   | 256        | 0.5 μm     |
|                        |                           |                      | 12.8                        | –   | 256        | 0.05 μm    |
|                        |                           |                      | 0.256                       | –   | 256        | 0.001 μm   |
|                        | RLS d.o.o.                | LA11YA Series        | 2,000                       | –   | 2,048      | 0.9765 μm  |
|                        |                           |                      | 2,000                       | –   | 4,096      | 0.4882 μm  |
|                        |                           |                      | 2,000                       | –   | 8,192      | 0.2441 μm  |
|                        | Magnescale Co., Ltd.      | SR77-□□□□LF          | 80                          | –   | 8,192      | 0.0098 μm  |
|                        |                           |                      | 80                          | –   | 1,024      | 0.078 μm   |
|                        |                           | SR87-□□□□LF          | 80                          | –   | 8,192      | 0.0098 μm  |
|                        |                           |                      | 80                          | –   | 1,024      | 0.078 μm   |
|                        |                           | SQ47/SQ57-□□□□SF□□□  | 20.48                       | –   | 4,096      | 0.005 μm   |
|                        |                           |                      | 40.96                       | –   | 4,096      | 0.01 μm    |
|                        | Fagor Automation S. Coop. | L2AK208              | 20                          | –   | 256        | 0.078 μm   |
|                        |                           |                      | 20                          | –   | 2,048      | 0.0098 μm  |
|                        |                           |                      | 40                          | –   | 512        | 0.078 μm   |
|                        |                           |                      | 40                          | –   | 4,096      | 0.0098 μm  |
|                        |                           |                      | 20                          | –   | 256        | 0.078 μm   |
|                        |                           |                      | 20                          | –   | 256        | 0.078 μm   |
|                        |                           |                      | 20                          | –   | 256        | 0.078 μm   |
|                        |                           |                      | 20                          | –   | 2,048      | 0.0098 μm  |
|                        |                           |                      | 20                          | –   | 2,048      | 0.0098 μm  |
| 20                     |                           |                      | –                           | 2,048   | 0.0098 μm  |            |
| Canon Precision Inc.   | PH03-36E00                | 128                  | –                           | 2,048   | 0.0625 μm  |            |

\*1. These are reference values for setting SERVOPACK parameters. Contact the manufacturer for actual linear encoder scale pitches.

\*2. This is the model of the Serial Converter Unit.

\*3. This is the model of the Head with Interpolator.

\*4. This is the model of the Interpolator.

\*5. Sales of the interface unit EIB3391Y with the LIC4100 and LIC2100 series have ended due to the release of the LIC4190, LIC3190, and LIC2190 series.

\*6. This is the model of the Interface Unit.

**Information**

**Resolution**

You can calculate the resolution that is used inside the SERVOPACK (i.e., the travel distance per feedback pulse) with the following formula.

$$\text{Resolution (travel distance per feedback pulse)} = \frac{\text{Linear encoder pitch}}{\text{Resolution of Serial Converter Unit or linear encoder}}$$

The SERVOPACK uses feedback pulses as the unit to control a Servomotor.

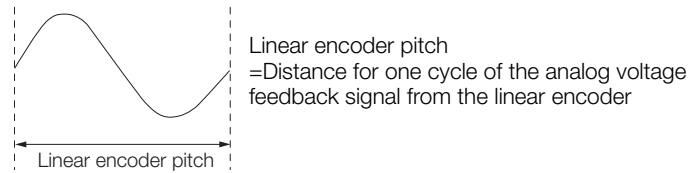

## Electronic Gear Ratio Setting Examples

Setting examples are provided in this section.

- Rotary Servomotors

| Step | Description   | Machine Configuration  |  |  |
|------|---|--|--|--|
|      |   | Ball Screw   | Rotary Table   | Belt and Pulley  |
|      |   |  |  |  |
| 1    | Machine Specifications                                      | <ul style="list-style-type: none"> <li>• Ball screw lead: 6 mm</li> <li>• Gear ratio: 1/1</li> </ul> | <ul style="list-style-type: none"> <li>• Rotation angle per revolution: 360°</li> <li>• Gear ratio: 1/100</li> </ul> | <ul style="list-style-type: none"> <li>• Pulley dia.: 100 mm (Pulley circumference: 314 mm)</li> <li>• Gear ratio: 1/50</li> </ul> |
| 2    | Encoder Resolution  | 16,777,216 (24 bits)   | 16,777,216 (24 bits)   | 16,777,216 (24 bits)   |
| 3    | Reference Unit  | 0.001 mm (1 μm)  | 0.01°  | 0.005 mm (5 μm)  |
| 4    | Travel Distance per Load Shaft Revolution (Reference Units) | 6 mm/0.001 mm = 6,000  | 360°/0.01° = 36,000  | 314 mm/0.005 mm = 62,800   |
| 5    | Electronic Gear Ratio*                                      | $\frac{B}{A} = \frac{16,777,216}{6,000} \times \frac{1}{16} \times \frac{1}{1}$                      | $\frac{B}{A} = \frac{16,777,216}{36,000} \times \frac{1}{16} \times \frac{100}{1}$                                   | $\frac{B}{A} = \frac{16,777,216}{62,800} \times \frac{1}{16} \times \frac{50}{1}$  |
| 6    | Position User Unit (2701h)                                  | Numerator: 1,048,576   | Numerator: 104,857,600   | Numerator: 52,428,800  |
|      |   | Denominator: 6,000   | Denominator: 36,000  | Denominator: 62,800  |

\* For a Rotary Servomotor with an encoder resolution of 24 bits (16,777,216), Pn20E (Electronic Gear Ratio (Numerator)) is automatically set to 16 and Pn210 (Electronic Gear Ratio (Denominator)) is automatically set to 1. Therefore, the encoder resolution will be equivalent to 20 bits (1,048,576). Consider this when you set the position reference unit in *position user unit* (2701h).

- Linear Servomotors

A setting example for a Serial Converter Unit resolution of 256 is given below.

| Step | Description                | Machine Configuration   |
|------|----------------------------|---|
|      |                            |   |
| 1    | Linear Encoder Pitch       | 0.02 mm (20 μm)   |
| 2    | Reference Unit             | 0.001 mm (1 μm)   |
| 3    | Electronic Gear Ratio*     | $\frac{B}{A} = \frac{1 (\mu\text{m})}{20 (\mu\text{m})} \times 256$ |
| 4    | Position User Unit (2701h) | Numerator: 256  |
|      |                            | Denominator: 20   |

\* For a Linear Servomotor, both Pn20E (Electronic Gear Ratio (Numerator)) and Pn210 (Electronic Gear Ratio (Denominator)) are automatically set to 1. Consider this when you set the position reference unit in *position user unit* (2701h).

## 6.14.2 Setting the Speed Reference Unit

Set the speed reference unit [Vel Unit] in *velocity user unit* (2702h).

For a Rotary Servomotor with an encoder resolution of 24 bits (16,777,216), Pn20E (Electronic Gear Ratio (Numerator)) is automatically set to 16 and Pn210 (Electronic Gear Ratio (Denominator)) is automatically set to 1. Therefore, the encoder resolution will be equivalent to 20 bits (1,048,576). Consider this when you set the position reference unit in *position user unit* (2701h).

| Index | Sub-index | Name              | Data Type | Access | PDO Mappings | Value                           | Saving to EEPROM |
|-------|-----------|-------------------|-----------|--------|--------------|---------------------------------|------------------|
| 2702h | 0         | Number of entries | USINT     | RO     | No           | 2                               | No               |
|       | 1         | Numerator         | UDINT     | RW     | No           | 1 to 1,073,741,823 (default: 1) | Yes              |
|       | 2         | Denominator       | UDINT     | RW     | No           | 1 to 1,073,741,823 (default: 1) | Yes              |

Setting range:  $1/128 \leq \text{Numerator/Denominator} \leq 8,388,608$   
 (Alarm A.A20 will be detected if the setting exceeds the setting range.)

**Example** Speed Reference Unit Setting Example (Electronic Gear Ratio Setting Example for a Ball Screw)

- Velocity User Unit (2702h)  
 Converting one user-defined velocity reference unit [0.1 mm/s] into [inc/s]:

$$\begin{aligned}
 & 1 \text{ [Vel unit]} \\
 &= \frac{16,777,216 \text{ [inc]} \times (1/16)}{6 \text{ [mm]}} \times 0.1 \text{ [mm/s]} \\
 &= \frac{1,048,576}{60} \text{ [inc/s]}
 \end{aligned}$$

Therefore, the objects are set as follows:  
 Object 2702h: 01 (Numerator) = 1,048,576  
 Object 2702h: 02 (Denominator) = 60



## 6.14.3 Setting the Acceleration Reference Unit

Set the acceleration reference unit [Acc Unit] in *acceleration user unit* (2703h).



For a Rotary Servomotor with an encoder resolution of 24 bits (16,777,216), Pn20E (Electronic Gear Ratio (Numerator)) is automatically set to 16 and Pn210 (Electronic Gear Ratio (Denominator)) is automatically set to 1. Therefore, the encoder resolution will be equivalent to 20 bits (1,048,576). Consider this when you set the position reference unit in *position user unit* (2701h).

| Index | Sub-index | Name              | Data Type | Access | PDO Mappings | Value                           | Saving to EEPROM |
|-------|-----------|-------------------|-----------|--------|--------------|---------------------------------|------------------|
| 2703h | 0         | Number of entries | USINT     | RO     | No           | 2                               | No               |
|       | 1         | Numerator         | UDINT     | RW     | No           | 1 to 1,073,741,823 (default: 1) | Yes              |
|       | 2         | Denominator       | UDINT     | RW     | No           | 1 to 1,073,741,823 (default: 1) | Yes              |

Setting range:  $1/128 \leq \text{Numerator/Denominator} \leq 262,144$

(Alarm A.A20 will be detected if the setting exceeds the setting range.)

### Example

Acceleration Reference Unit Setting Example (Electronic Gear Ratio Setting Example for a Ball Screw)

- Acceleration User Unit (2703h)

Converting one user-defined acceleration reference unit [0.1 mm/s<sup>2</sup>] into [10<sup>4</sup> inc/s<sup>2</sup>]:

$$\begin{aligned}
 & 1 [\text{Acc unit}] \\
 &= \frac{16,777,216 [\text{inc}] \times (1/16)}{6 [\text{mm}]} \times 0.1 [\text{mm/s}^2] \times 10^{-4} \\
 &= \frac{1,048,576}{6 \times 10^5} [10^4 \text{ inc/s}^2]
 \end{aligned}$$

Therefore, the objects are set as follows:

Object 2703h: 01 (Numerator) = 1,048,576

Object 2703h: 02 (Denominator) = 600,000

## 6.14.4 Setting the Torque Reference Unit

Set the torque reference unit [Torque Unit] in *torque user unit* (2704h).

| Index | Sub-index | Name              | Data Type | Access | PDO Mappings | Value                            | Saving to EEPROM |
|-------|-----------|-------------------|-----------|--------|--------------|----------------------------------|------------------|
| 2704h | 0         | Number of entries | USINT     | RO     | No           | 2                                | No               |
|       | 1         | Numerator         | UDINT     | RW     | No           | 1 to 1,073,741,823 (default: 1)  | Yes              |
|       | 2         | Denominator       | UDINT     | RW     | No           | 1 to 1,073,741,823 (default: 10) | Yes              |

Setting range:  $1/256 \leq \text{Numerator/Denominator} \leq 1$

(Alarm A.A20 will be detected if the setting exceeds the setting range.)

## 6.14.5 Setting the Encoder Resolution

If you use an SGM7J, SGM7A, or SGM7G Servomotor, you can set the resolution of the encoder to 20 bits or 24 bits.

Set the encoder resolution in *encoder selection* (2705h).

| Index | Sub-index | Name              | Data Type | Access | PDO Mappings | Value   | Saving to EEPROM |
|-------|-----------|-------------------|-----------|--------|--------------|---|------------------|
| 2705h | 0         | Encoder Selection | UINT      | RW     | No           | 0000h (20 bits),<br>0001h (24 bits)<br>(default: 0000h) | Yes              |

## 6.15 Resetting the Absolute Encoder

In a system that uses an absolute encoder, the multiturn data must be reset at startup. An alarm related to the absolute encoder (A.810 or A.820) will occur when the absolute encoder must be reset, such as when the power supply is turned ON.

When you reset the absolute encoder, the multiturn data is reset and any alarms related to the absolute encoder are cleared.

Reset the absolute encoder in the following cases.

- When an A.810 alarm (Encoder Backup Alarm) occurs
- When an A.820 alarm (Encoder Checksum Alarm) occurs
- When starting the system for the first time
- When you want to reset the multiturn data in the absolute encoder
- When the Servomotor has been replaced



### CAUTION

- The multiturn data will be reset to a value between -2 and +2 rotations when the absolute encoder is reset. The reference position of the machine system will change. Adjust the reference position in the host controller to the position that results from resetting the absolute encoder.  
If the machine is started without adjusting the position in the host controller, unexpected operation may cause personal injury or damage to the machine.

#### Information

When the encoder is set to be used as a single-turn absolute encoder (Pn002 = n.□2□□), the multiturn data will always be zero. It is not necessary to reset the absolute encoder. Also, an alarm related to the absolute encoder (A.810 or A.820) will not occur.

### 6.15.1 Precautions on Resetting

- You cannot use the ALM\_CLR (Clear Alarm) command from the SERVOPACK to clear the A.810 alarm (Encoder Backup Alarm) or the A.820 alarm (Encoder Checksum Alarm). Always use the operation to reset the absolute encoder to clear these alarms.
- If an A.8□□ alarm (Internal Encoder Monitoring Alarm) occurs, turn OFF the power supply to reset the alarm.

### 6.15.2 Preparations

Always check the following before you reset an absolute encoder.

- The parameters must not be write prohibited.
- The servo must be OFF for both axis A and axis B.

### 6.15.3 Applicable Tools

The following table lists the tools that you can use to reset the absolute encoder.

| Tool                          | Fn No./Function Name                            | Reference  |
|-------------------------------|---|--|
| Digital Operator              | Fn008   | Σ-7-Series Digital Operator Operating Manual (Manual No.: SIEP S800001 33) |
| SigmaWin+                     | <b>Encoder Setting - Reset Absolute Encoder</b> | 6.15.4 Operating Procedure on page 6-49                                    |
| EtherCAT (CoE) communications | SERVOPACK Adjusting Command (2710h)             | SERVOPACK Adjusting Command (A: 2710h, B: 2F10h) on page 14-24             |

## 6.15.4 Operating Procedure

Use the following procedure to reset the absolute encoder.

1. Confirm that the servo is OFF.
2. Click the  Servo Drive Button in the workspace of the Main Window of the SigmaWin+.
3. Select **Absolute Encoder Reset** in the Menu Dialog Box.  
The Absolute Encoder Reset Dialog Box will be displayed.
4. Click the **Continue** Button.

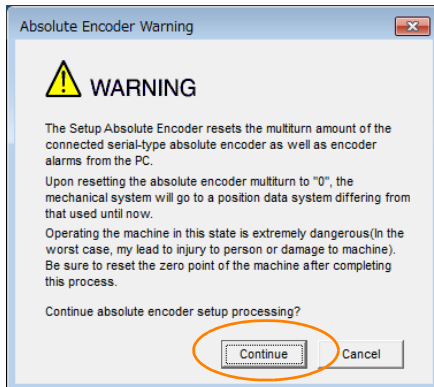

Click the **Cancel** Button to cancel resetting the absolute encoder. The Main Window will return.

5. Click the **Execute setting** Button.

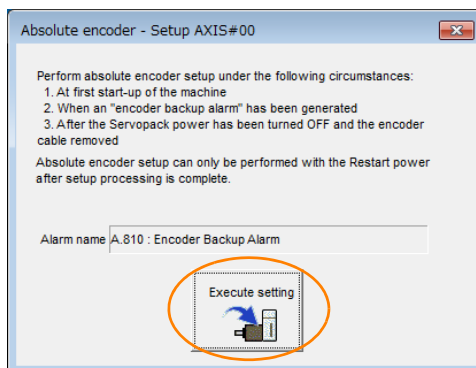

The current alarm code and name will be displayed in the **Alarm name** Box.

6. Click the **Continue** Button.

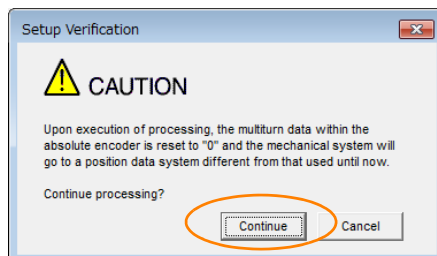

Click the **Cancel** Button to cancel resetting the absolute encoder. The previous dialog box will return.

**7. Click the OK Button.**

The absolute encoder will be reset.

**When Resetting Fails**

If you attempted to reset the absolute encoder when the servo was ON in the SERVOPACK, the following dialog box will be displayed and processing will be canceled.

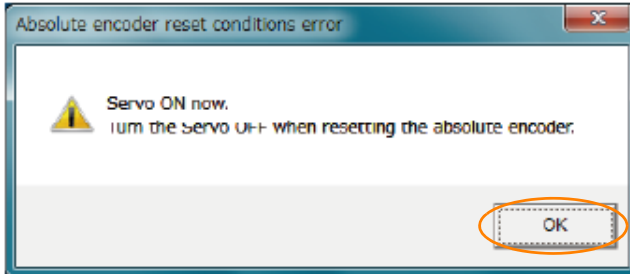

Click the **OK** Button. The Main Window will return. Turn OFF the servo and repeat the procedure from step 1.

**When Resetting Is Successful**

The following dialog box will be displayed when the absolute encoder has been reset.

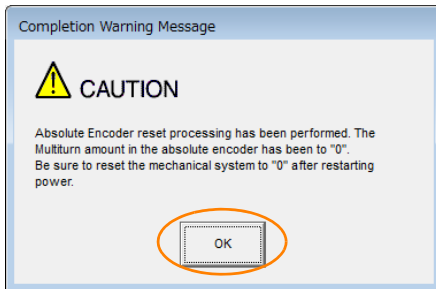

The Main Window will return.

**8. To enable the change to the settings, turn the power supply to the SERVOPACK OFF and ON again.**

This concludes the procedure to reset the absolute encoder.

## 6.16 Setting the Origin of the Absolute Encoder

### 6.16.1 Absolute Encoder Origin Offset

The origin offset of the absolute encoder is a correction that is used to set the origin of the machine coordinate system in addition to the origin of the absolute encoder. Set the offset between the absolute encoder origin and the machine coordinate system position in *home offset* (607Ch).

The offset is added to *position actual value* (6064h) after the parameters are enabled when the power supply is turned ON or with *user parameter configuration* (2700h).

| Index | Subindex | Name        | Data Type | Access | Data Ranges                 | Default Value | Saving to EEPROM |
|-------|----------|-------------|-----------|--------|-----------------------------|---------------|------------------|
| 607Ch | 0        | Home offset | DINT      | RW     | -536,870,912 to 536,870,911 | 0             | Yes              |

**Example** If the encoder position (X) is at the origin (0), then *home offset* (607Ch) would be set to the value of -X.

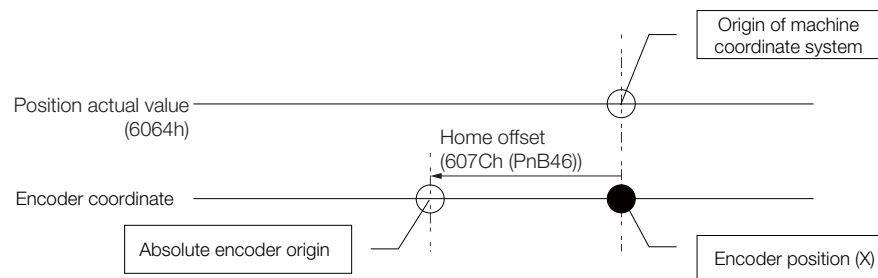

### 6.16.2 Setting the Origin of the Absolute Linear Encoder

You can set any position as the origin in the following linear encoders.

- Dr. JOHANNES HEIDENHAIN GmbH  
LIC4190, LIC3190, or LIC2190 Series
- RSF Elektronik GmbH  
MC15Y Series
- Mitutoyo Corporation  
ABS ST780A Series or ST1300 Series  
Models: ABS ST78□A/ST78□AL/ST13□□
- Renishaw PLC  
EVOLUTE Series  
Models: EL36Y□□□□□□□□□□
- Renishaw PLC  
RESOLUTE Series  
Models: RL36Y□□□□□□□□□□
- Canon Precision Inc.  
Model: PH03-36E00



Important

1. After you set the origin, the /S-RDY (Servo Ready) signal will become inactive because the system position data was changed. Always turn the SERVOPACK power supply OFF and ON again.
2. After you set the origin, the Servomotor phase data in the SERVOPACK will be discarded. If you are using a Linear Servomotor without a Polarity Sensor, execute polarity detection again to save the Servomotor phase data in the SERVOPACK.



## Preparations

The following conditions must be met to set the origin of the absolute linear encoder.

- The parameters must not be write prohibited.
- The servo must be OFF.

## Applicable Tools

The following table lists the tools that you can use to set the origin of the absolute linear encoder.

| Tool             | Fn No./Function Name                                 | Reference   |
|------------------|--|---|
| Digital Operator | Fn020  |  $\Sigma$ -7-Series Digital Operator Operating Manual (Manual No.: SIEP S800001 33) |
| SigmaWin+        | <b>Encoder Setting - Zero Point Position Setting</b> |  Operating Procedure on page 6-52   |

## Operating Procedure

Use the following procedure to set the origin of an absolute linear encoder.

1. Click the  Servo Drive Button in the workspace of the Main Window of the SigmaWin+.
2. Select **Set Origin** in the Menu Dialog Box.  
The Set Origin Dialog Box will be displayed.
3. Click the **Continue** Button.

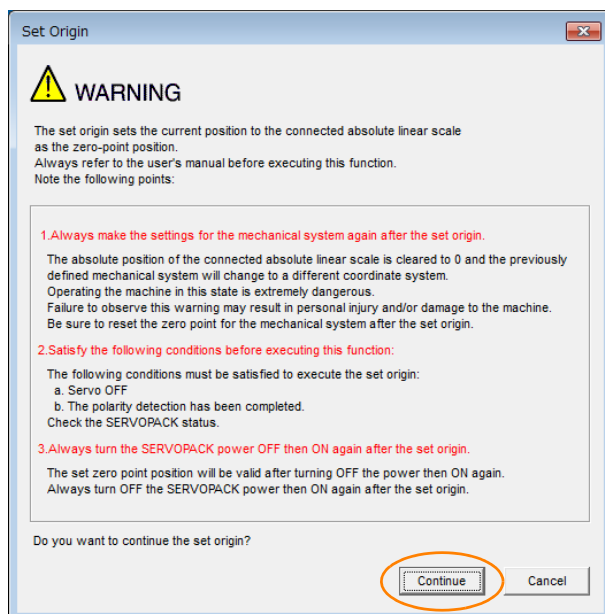

4. Click the **Execute** Button.

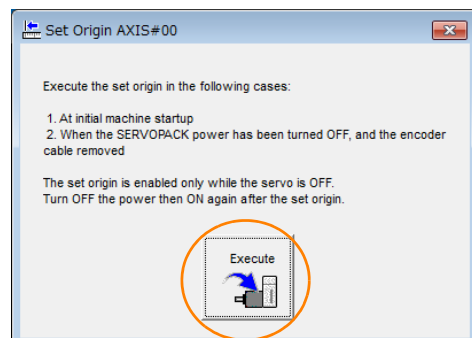

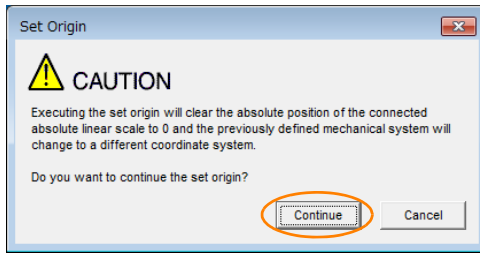
5. Click the **Continue** Button.

Click the **Cancel** Button to cancel setting the origin of the absolute linear encoder. The previous dialog box will return.

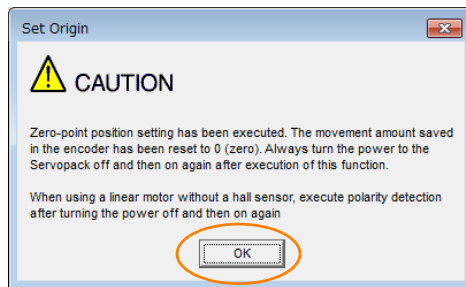
6. Click the **OK** Button.

## 7. Turn the power supply to the SERVOPACK OFF and ON again.

## 8. If you use a Linear Servomotor that does not have a polarity sensor, perform polarity detection.

Refer to the following section for details on the polarity detection.

 [6.9 Polarity Detection](#) on page 6-22

This concludes the procedure to set the origin of the absolute linear encoder.

# 6.17 Setting the Regenerative Resistor Capacity

The Regenerative Resistor consumes regenerative energy that is generated by the Servomotor, e.g., when the Servomotor decelerates.

If an External Regenerative Resistor is connected, you must set Pn600 (Regenerative Resistor Capacity) and Pn603 (Regenerative Resistance).

Note: When using the SERVOPACK's built-in regenerative resistor (not using an External Regenerative Resistor), use the default setting of 0 for Pn600 and Pn603.

**WARNING**

- If you connect an External Regenerative Resistor, set Pn600 and Pn603 to suitable values. If a suitable value is not set, A.320 alarms (Regenerative Overload) will not be detected correctly, and the External Regenerative Resistor may be damaged or personal injury or fire may result.
- When you select an External Regenerative Resistor, make sure that it has a suitable capacity. There is a risk of personal injury or fire.

| <b>Pn600</b><br>(2600h)<br><small>Common</small> | Regenerative Resistor Capacity                                 |              |                 |              | <small>Speed</small> | <small>Position</small> | <small>Torque</small> |
|--|--|--------------|-----------------|--------------|----------------------|-------------------------|-----------------------|
|  | Setting Range  | Setting Unit | Default Setting | When Enabled | Classification       |                         |                       |
|  | 0 to 2 times the SERVOPACK's maximum applicable motor capacity | 10 W         | 0               | Immediately  | Setup                |                         |                       |
| <b>Pn603</b><br>(2603h)<br><small>Common</small> | Regenerative Resistance  |              |                 |              | <small>Speed</small> | <small>Position</small> | <small>Torque</small> |
|  | Setting Range  | Setting Unit | Default Setting | When Enabled | Classification       |                         |                       |
|  | 0 to 65,535  | 10 mΩ        | 0               | Immediately  | Setup                |                         |                       |

Set the Regenerative Resistor capacity to a value that is consistent with the allowable capacity of the External Regenerative Resistor. The setting depends on the cooling conditions of the External Regenerative Resistor.

- For self-cooling (natural convection cooling): Set the parameter to a maximum 20% of the capacity (W) of the actually installed Regenerative Resistor.
- For forced-air cooling: Set the parameter to a maximum 50% of the capacity (W) of the actually installed Regenerative Resistor.

**Example** For a self-cooling 100-W External Regenerative Resistor, set Pn600 to 2 (×10 W) (100 W × 20% = 20 W).

Note: An A.320 alarm will be displayed if the setting is not suitable.

Important

1. When an External Regenerative Resistor is used at the normal rated load ratio, the resistor temperature increases to between 200°C and 300°C. Always apply derating. Consult the manufacturer for the resistor's load characteristics.
2. For safety, use an External Regenerative Resistor with a thermoswitch.



# Application Functions



This chapter describes the application functions that you can set before you start Servo System operation. It also describes the setting methods.

|            |  |             |
|------------|--|-------------|
| <b>7.1</b> | <b>I/O Signal Allocations . . . . .</b>                | <b>7-3</b>  |
| 7.1.1      | Input Signal Allocations . . . . .                     | 7-4         |
| 7.1.2      | Output Signal Allocations . . . . .                    | 7-7         |
| 7.1.3      | ALM (Servo Alarm) Signal . . . . .                     | 7-10        |
| 7.1.4      | /WARN (Warning) Signal . . . . .                       | 7-10        |
| 7.1.5      | /TGON (Rotation Detection) Signal . . . . .            | 7-11        |
| 7.1.6      | /S-RDY (Servo Ready) Signal . . . . .                  | 7-12        |
| 7.1.7      | /V-CMP (Speed Coincidence Detection) Signal . . . . .  | 7-12        |
| 7.1.8      | /COIN (Positioning Completion) Signal . . . . .        | 7-14        |
| 7.1.9      | /NEAR (Near) Signal . . . . .                          | 7-15        |
| 7.1.10     | Speed Limit during Torque Control . . . . .            | 7-16        |
| <b>7.2</b> | <b>Operation for Momentary Power Interruptions . .</b> | <b>7-18</b> |
| <b>7.3</b> | <b>SEMI F47 Function . . . . .</b>                     | <b>7-19</b> |
| <b>7.4</b> | <b>Setting the Motor Maximum Speed . . . . .</b>       | <b>7-21</b> |
| <b>7.5</b> | <b>Software Limits . . . . .</b>                       | <b>7-22</b> |
| <b>7.6</b> | <b>Selecting Torque Limits . . . . .</b>               | <b>7-23</b> |
| 7.6.1      | Internal Torque Limits . . . . .                       | 7-23        |
| 7.6.2      | External Torque Limits . . . . .                       | 7-24        |
| 7.6.3      | /CLT (Torque Limit Detection) Signal . . . . .         | 7-27        |

**7.7 Absolute Encoders . . . . . 7-28**

- 7.7.1 Connecting an Absolute Encoder . . . . . 7-28
- 7.7.2 Structure of the Position Data of the Absolute Encoder . . . . . 7-28
- 7.7.3 Multiturn Limit Setting . . . . . 7-29
- 7.7.4 Multiturn Limit Disagreement Alarm (A.CC0) . . . 7-31

**7.8 Absolute Linear Encoders . . . . . 7-34**

- 7.8.1 Connecting an Absolute Linear Encoder . . . . . 7-34
- 7.8.2 Structure of the Position Data of the Absolute Linear Encoder . . . . . 7-34

**7.9 Software Reset . . . . . 7-35**

- 7.9.1 Preparations . . . . . 7-35
- 7.9.2 Applicable Tools . . . . . 7-35
- 7.9.3 Operating Procedure . . . . . 7-36

**7.10 Initializing the Vibration Detection Level . . 7-37**

- 7.10.1 Preparations . . . . . 7-37
- 7.10.2 Applicable Tools . . . . . 7-38
- 7.10.3 Operating Procedure . . . . . 7-38
- 7.10.4 Related Parameters . . . . . 7-40

**7.11 Adjusting the Motor Current Detection Signal Offset . . 7-41**

- 7.11.1 Automatic Adjustment . . . . . 7-41
- 7.11.2 Manual Adjustment . . . . . 7-43

**7.12 Forcing the Motor to Stop . . . . . 7-45**

- 7.12.1 FSTP (Forced Stop Input) Signal . . . . . 7-45
- 7.12.2 Stopping Method Selection for Forced Stops . . . . . 7-45
- 7.12.3 Resetting Method for Forced Stops . . . . . 7-47

**7.13 Overheat Protection . . . . . 7-48**





- 7.13.1 Connecting the Overheat Protection Input (TH) Signal . . . . . 7-48
- 7.13.2 Overheat Protection Selections . . . . . 7-49

## 7.1 I/O Signal Allocations

Functions are allocated to the pins on the I/O signal connector (CN1) in advance. You can change the allocations and the polarity for some of the connector pins. Function allocations and polarity settings are made with parameters.

This section describes the I/O signal allocations.

There are the following two methods to allocate I/O signals.

| Allocation Method                              | Description  | Reference  |
|--|--|--|
| $\Sigma$ -7S-Compatible I/O Signal Allocations | The same parameters as $\Sigma$ -7S are used to allocate I/O signals to pin numbers. The pin numbers that can be allocated for the axis A and the pin numbers that can be allocated for the axis B are predetermined.  | <ul style="list-style-type: none"> <li>Input Signals<br/>  <math>\Sigma</math>-7S-Compatible Input Signal Allocations on page 7-4</li> <li>Output Signals<br/>  <math>\Sigma</math>-7S-Compatible Output Signal Allocations on page 7-7</li> </ul> |
| Multi-Axis I/O Signal Allocations              | Multi-axis parameters are used to allocate I/O signals to the pin numbers. Signals can be allocated to any pin number for both the axis A and axis B as long as the pin numbers are within the following range. <ul style="list-style-type: none"> <li>Input signal: CN1-7 to CN1-13, CN1-18 to CN1-20</li> <li>Output signal: CN1-1, CN1-2, CN1-23 to CN1-30</li> </ul> | <ul style="list-style-type: none"> <li>Input Signals<br/>  Multi-Axis Input Signal Allocations on page 7-6</li> <li>Output Signals<br/>  Multi-Axis Output Signal Allocations on page 7-9</li> </ul>   |

Specify the allocation method to use in Pn50A = n.□□□X (I/O Signal Allocation Mode).

| Parameter     | Description              | When Enabled  | Classification |
|---------------|--------------------------|---------------|----------------|
| Pn50A (250Ah) | n.□□□1 (default setting) | After restart | Setup          |
|               | n.□□□2                   |               |                |

## 7.1.1 Input Signal Allocations



- If you change the default polarity settings for the P-OT (Forward Drive Prohibit) or N-OT (Reverse Drive Prohibit) signal, the overtravel function will not operate if there are signal line disconnections or other problems. If you must change the polarity of one of these signals, verify operation and make sure that no safety problems will exist.
- If you allocate two or more signals to the same input circuit, a logical OR of the inputs will be used and all of the allocated signals will operate accordingly. This may result in unexpected operation.

### Σ-7S-Compatible Input Signal Allocations

Pin numbers 7 to 11 on the I/O signal connector (CN1) are used for the A-axis, and pin numbers 12, 13, 18 to 20 are used for the B-axis.

The signals shown in the figure are allocated at shipping.

| No | Signal           | Specification                               | No | Signal            | Specification                               |
|----|------------------|---|----|-------------------|---|
| 15 | BAT_A-           | Battery for Absolute Encoder (-) for Axis A | 30 | /SO5-             | General-purpose Sequence Output 5           |
| 14 | BAT_A+           | Battery for Absolute Encoder (+) for Axis A | 29 | /SO5+             | General-purpose Sequence Output 5           |
| 13 | /SI12 (N-OT_B)   | General-purpose Sequence Input 12           | 28 | /SO4-             | General-purpose Sequence Output 4           |
| 12 | /SI11 (P-OT_B)   | General-purpose Sequence Input 11           | 27 | /SO4+             | General-purpose Sequence Output 4           |
| 11 | /SI5 (/Home_A)   | General-purpose Sequence Input 5            | 26 | /SO3-             | General-purpose Sequence Output 3           |
| 10 | /SI4 (/Probe2_A) | General-purpose Sequence Input 4            | 25 | /SO3+             | General-purpose Sequence Output 3           |
| 9  | /SI3 (/Probe1_A) | General-purpose Sequence Input 3            | 24 | /SO2- (/BK_B-)    | General-purpose Sequence Output 2           |
| 8  | /SI2 (N-OT_A)    | General-purpose Sequence Input 2            | 23 | /SO2+ (/BK_B+)    | General-purpose Sequence Output 2           |
| 7  | /SI1 (P-OT_A)    | General-purpose Sequence Input 1            | 22 | BAT_B-            | Battery for Absolute Encoder (-) for Axis B |
| 6  | +24VIN           | Sequence input signal power supply input    | 21 | BAT_B+            | Battery for Absolute Encoder (+) for Axis B |
| 5  | TH_A             | Overheat Protection Input for Axis A        | 20 | /SI15 (/Home_B)   | General-purpose Sequence Input 15           |
| 4  | ALM-             | Servo Alarm Output                          | 19 | /SI14 (/Probe2_B) | General-purpose Sequence Input 14           |
| 3  | ALM+             | Servo Alarm Output                          | 18 | /SI13 (/Probe1_B) | General-purpose Sequence Input 13           |
| 2  | /SO1- (/BK_A-)   | General-purpose Sequence Output 1           | 17 | TH_B              | Overheat Protection Input for Axis B        |
| 1  | /SO1+ (/BK_A+)   | General-purpose Sequence Output 1           | 16 | SG                | Signal ground                               |

The input signals that you can allocate to the pins on the I/O signal connector (CN1) and the related parameters are given in the following table.

| Input Signal | Input Signal Name             | Parameter              |
|--------------|-------------------------------|------------------------|
| P-OT         | Forward Drive Prohibit        | Pn50A (250Ah) = n.X□□□ |
| N-OT         | Reverse Drive Prohibit        | Pn50B (250Bh) = n.□□□X |
| /P-CL        | Forward External Torque Limit | Pn50B (250Bh) = n.□X□□ |
| /N-CL        | Reverse External Torque Limit | Pn50B (250Bh) = n.X□□□ |
| /Probe1      | Probe 1 Latch Input           | Pn511 (2511h) = n.□□□X |
| /Probe2      | Probe 2 Latch Input           | Pn511 (2511h) = n.□□X□ |

Continued on next page.

Continued from previous page.

| Input Signal | Input Signal Name | Parameter              |
|--------------|-------------------|------------------------|
| /Home        | /Home Input       | Pn511 (2511h) = n.□X□□ |
| FSTP         | Forced Stop       | Pn516 (2516h) = n.□□□X |

### ◆ Relationship between Parameter Settings, Allocated Pins, and Polarities

The following table shows the relationship between the input signal parameter settings, the pins on the I/O signal connector (CN1), and polarities.

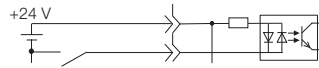
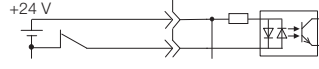
| Parameter Setting | Pin No. |        | Description   |
|-------------------|---------|--------|---|
|                   | Axis A  | Axis B |   |
| 0                 | –       | –      | Reserved parameter (Do not change.)   |
| 1                 | 7       | 12     |  <p>A reverse signal (a signal with “/” before the signal abbreviation, such as the /P-CL signal) is active when the contacts are ON (closed).<br/>A signal that does not have “/” before the signal abbreviation (such as the P-OT signal) is active when the contacts are OFF (open).</p>   |
| 2                 | 8       | 13     |   |
| 3                 | 9       | 18     |   |
| 4                 | 10      | 19     |   |
| 5                 | 11      | 20     |   |
| 6                 | –       | –      | Reserved parameter (Do not change.)   |
| 7                 | –       | –      | The input signal is not allocated to a connector pin and it is always active. If the signal is processed on a signal edge, then it is always inactive.  |
| 8                 | –       | –      | The input signal is not allocated to a connector pin and it is always inactive. Set the parameter to 8 if the signal is not used.   |
| 9                 | –       | –      | Reserved parameter (Do not change.)   |
| A                 | 7       | 12     |  <p>A reverse signal (a signal with “/” before the signal abbreviation, such as the /P-CL signal) is active when the contacts are OFF (open).<br/>A signal that does not have “/” before the signal abbreviation (such as the P-OT signal) is active when the contacts are ON (closed).</p> |
| B                 | 8       | 13     |   |
| C                 | 9       | 18     |   |
| D                 | 10      | 19     |   |
| E                 | 11      | 20     |   |
| F                 | –       | –      | Reserved parameter (Do not change.)   |

Note: 1. You can allocate the /Probe1, /Probe2, and /Home input signals only to pins 7 to 11, 12, 13, or 18 to 20 on the I/O signal connector (CN1).

2. Refer to the following section for details on input signal parameter settings.

 16.1.2 List of Parameters on page 16-3

### ◆ Example of Changing Input Signal Allocations

The following example shows reversing the P-OT (Forward Drive Prohibit) signal allocated to CN1-7 and CN1-12 and the N-OT (Reverse Drive Prohibit) signal allocated to CN1-8 and CN1-13.

Pn50A = n.1□□2      Pn50B = n.□□□2      Before change

↓

↓

Pn50A = n.2□□1      Pn50B = n.□□□1      After change

Refer to the following section for the parameter setting procedure.

 6.1.3 SERVOPACK Parameter Setting Methods on page 6-5

## Multi-Axis Input Signal Allocations

You can allocate the signals for both the axis A and axis B to pins 7 to 13, and 18 to 20 on the I/O signal connector (CN1).

The input signals that you can allocate to the pins on the I/O signal connector (CN1) and the related parameters are given in the following table.

| Input Signal | Input Signal Name                    | Parameter     |
|--------------|--------------------------------------|---------------|
| P-OT         | Forward Drive Prohibit Input Signal  | Pn590 (2590h) |
| N-OT         | Reverse Drive Prohibit Signal        | Pn591 (2591h) |
| Probe1       | Probe 1 Latch Input Signal           | Pn593 (2593h) |
| Probe2       | Probe 2 Latch Input Signal           | Pn594 (2594h) |
| /HOME        | Home Switch Input Signal             | Pn595 (2595h) |
| FSTP         | Forced Stop Input Signal             | Pn597 (2597h) |
| /P-CL        | Forward External Torque Limit Signal | Pn598 (2598h) |
| /N-CL        | Reverse External Torque Limit Signal | Pn599 (2599h) |

### ◆ Relationship between Parameter Settings, Allocated Pins, and Polarities

This section shows the relationship between the input signal parameter settings, the pins on the I/O signal connector (CN1), and the polarities using Pn591 (N-OT (Reverse Drive Prohibit) Signal Allocation) as an example. Refer to the following section for information on individual input signals.

 16.1.2 List of Parameters on page 16-3

#### • Relationship between Parameter Settings and Pin Numbers

| Parameter        | Description                               | When Enabled  | Classification |
|------------------|---|---------------|----------------|
| Pn591<br>(2591h) | n.□007                                    | After restart | Setup          |
|                  | n.□008<br>(default setting<br>for axis A) |               |                |
|                  | n.□009                                    |               |                |
|                  | n.□010                                    |               |                |
|                  | n.□011                                    |               |                |
|                  | n.□012                                    |               |                |
|                  | n.□013<br>(default setting<br>for axis B) |               |                |
|                  | n.□018                                    |               |                |
|                  | n.□019                                    |               |                |
|                  | n.□020                                    |               |                |

#### • Relationship between Parameter Settings and Polarities

| Parameter        | Description                 | When Enabled  | Classification |
|------------------|-----------------------------|---------------|----------------|
| Pn591<br>(2591h) | n.0□□□                      | After restart | Setup          |
|                  | n.1□□□<br>(default setting) |               |                |
|                  | n.2□□□                      |               |                |
|                  | n.3□□□                      |               |                |

## Confirming the Allocation Status of Input Signals

You can confirm the allocation status of input signals with the I/O Signal Allocations Window of the SigmaWin+. Refer to the following section for details.

 10.2.3 I/O Signals Status Monitor on page 10-5

## 7.1.2 Output Signal Allocations

You can allocate the desired output signals to pins 1, 2, and 23 to 30 on the I/O signal connector (CN1). The parameters that you use to allocate signals depend on whether you use  $\Sigma$ -7S-compatible I/O signal allocations (Pn50A = n.□□□1) or multi-axis I/O signal allocations (Pn50A = n.□□□2).

### $\Sigma$ -7S-Compatible Output Signal Allocations

Pin numbers 1, 2, 25, and 26 on the I/O signal connector (CN1) are used for the axis A, and pin numbers 23, 24, 27, and 28 are used for the axis B.

Signals cannot be allocated to pin numbers 29 and 30.

| No | Signal           | Specification                               | No | Signal            | Specification                               |
|----|------------------|---|----|-------------------|---|
| 15 | BAT_A-           | Battery for Absolute Encoder (-) for Axis A | 30 | /SO5-             | General-purpose Sequence Output 5           |
| 14 | BAT_A+           | Battery for Absolute Encoder (+) for Axis A | 29 | /SO5+             | General-purpose Sequence Output 5           |
| 13 | /SI12 (N-OT_B)   | General-purpose Sequence Input 12           | 28 | /SO4-             | General-purpose Sequence Output 4           |
| 12 | /SI11 (P-OT_B)   | General-purpose Sequence Input 11           | 27 | /SO4+             | General-purpose Sequence Output 4           |
| 11 | /SI5 (/Home_A)   | General-purpose Sequence Input 5            | 26 | /SO3-             | General-purpose Sequence Output 3           |
| 10 | /SI4 (/Probe2_A) | General-purpose Sequence Input 4            | 25 | /SO3+             | General-purpose Sequence Output 3           |
| 9  | /SI3 (/Probe1_A) | General-purpose Sequence Input 3            | 24 | /SO2- (/BK_B-)    | General-purpose Sequence Output 2           |
| 8  | /SI2 (N-OT_A)    | General-purpose Sequence Input 2            | 23 | /SO2+ (/BK_B+)    | General-purpose Sequence Output 2           |
| 7  | /SI1 (P-OT_A)    | General-purpose Sequence Input 1            | 22 | BAT_B-            | Battery for Absolute Encoder (-) for Axis B |
| 6  | +24VIN           | Sequence input signal power supply input    | 21 | BAT_B+            | Battery for Absolute Encoder (+) for Axis B |
| 5  | TH_A             | Overheat Protection Input for Axis A        | 20 | /SI15 (/Home_B)   | General-purpose Sequence Input 15           |
| 4  | ALM-             | Servo Alarm Output                          | 19 | /SI14 (/Probe2_B) | General-purpose Sequence Input 14           |
| 3  | ALM+             | Servo Alarm Output                          | 18 | /SI13 (/Probe1_B) | General-purpose Sequence Input 13           |
| 2  | /SO1- (/BK_A-)   | General-purpose Sequence Output 1           | 17 | TH_B              | Overheat Protection Input for Axis B        |
| 1  | /SO1+ (/BK_A+)   | General-purpose Sequence Output 1           | 16 | SG                | Signal ground                               |

Cannot be allocated

Axis B

Axis A

Axis B

Axis A



- The signals that are not detected are considered to be OFF. For example, the /COIN (Positioning Completion) signal is considered to be OFF during speed control.
- Reversing the polarity of the /BK (Brake) signal, i.e., changing it to positive logic, will prevent the holding brake from operating if its signal line is disconnected. If you must change the polarity of this signal, verify operation and make sure that no safety problems will exist.
- If you allocate more than one signal to the same output circuit, a logical OR of the signals will be output.

The following table shows the relationship between the parameters and the output signals that can be allocated to the pins on the I/O signal connector (CN1).

| Output Signals | Output Signal Name          | Parameter              |
|----------------|-----------------------------|------------------------|
| /COIN          | Positioning Completion      | Pn50E (250Eh) = n.□□□X |
| /V-CMP         | Speed Coincidence Detection | Pn50E (250Eh) = n.□□X□ |
| /TGON          | Rotation Detection          | Pn50E (250Eh) = n.□X□□ |
| /S-RDY         | Servo Ready                 | Pn50E (250Eh) = n.X□□□ |
| /CLT           | Torque Limit Detection      | Pn50F (250Fh) = n.□□□X |
| /MLT           | Speed Limit Detection       | Pn50F (250Fh) = n.□□X□ |
| /BK            | Brake                       | Pn50F (250Fh) = n.□X□□ |
| /WARN          | Warning                     | Pn50F (250Fh) = n.X□□□ |
| /NEAR          | Near                        | Pn510 (2510h) = n.□□□X |
| /PM            | Preventative Maintenance    | Pn514 (2514h) = n.□X□□ |

### ◆ Relationship between Parameter Settings and Allocated Pin Numbers

The following table shows the relationship between the output signal parameter settings and the pin numbers on the I/O signal connector (CN1).

| Parameter Setting | Pin No.  |          | Description  |
|-------------------|----------|----------|--|
|                   | Axis A   | Axis B   |  |
| 0                 | –        | –        | Disable (signal output is not used)  |
| 1                 | 1 or 2   | 23 or 24 | Axis A: Output the allocated signal from the CN1-1 or CN1-2 output terminal.<br>Axis B: Output the allocated signal from the CN1-23 or CN1-24 output terminal.   |
| 2                 | 25 or 26 | 27 or 28 | Axis A: Output the allocated signal from the CN1-25 or CN1-26 output terminal.<br>Axis B: Output the allocated signal from the CN1-27 or CN1-28 output terminal. |
| 3 to 6            | –        | –        | Reserved parameter (Do not change.)  |

### ◆ Output Signal Polarity Switching

The polarity of output signals is switched using Pn512 (2512h).

| Parameter        |               | Pin No. |          | Description |                             |
|------------------|---------------|---------|----------|-------------|-----------------------------|
| Parameter No.    | Setting Value | Axis A  | Axis B   |             |                             |
| Pn512<br>(2512h) | n.□□□X        | 0       | 1 or 2   | 23 or 24    | The signal is not inverted. |
|                  |               | 1       |          |             | The signal is inverted.     |
|                  | n.□□X□        | 0       | 25 or 26 | 27 or 28    | The signal is not inverted. |
|                  |               | 1       |          |             | The signal is inverted.     |

### ◆ Example of Changing Output Signal Allocations

The following example shows disabling the /COIN (Positioning Completion) signal allocated to CN1-27 and CN1-28 and allocating the /S-RDY (Servo Ready) signal for axis B.

Pn50E = n.0□□2 Before change

↓

Pn50E = n.2□□0 After change

Refer to the following section for the parameter setting procedure.

 6.1.3 *SERVOPACK* Parameter Setting Methods on page 6-5



## Multi-Axis Output Signal Allocations

You can allocate the signals for both the axis A and axis B to pins 1, 2, and 23 to 30 on the I/O signal connector (CN1).

The output signals that you can allocate to the pins on the I/O signal connector (CN1) and the related parameters are given in the following table.

| Output Signal | Output Signal Name                        | Parameter     |
|---------------|---|---------------|
| /COIN         | Positioning Completion Output Signal      | Pn5B0 (25B0h) |
| /V-CMP        | Speed Coincidence Detection Output Signal | Pn5B1 (25B1h) |
| /TGON         | Rotation Detection Output Signal          | Pn5B2 (25B2h) |
| /S-RDY        | Servo Ready Output Signal                 | Pn5B3 (25B3h) |
| /CLT          | Torque Limit Detection Output Signal      | Pn5B4 (25B4h) |
| /VLT          | Speed Limit Detection Output Signal       | Pn5B5 (25B5h) |
| /BK           | Brake Output Signal                       | Pn5B6 (25B6h) |
| /WARN         | Warning Output Signal                     | Pn5B7 (25B7h) |
| /NEAR         | Near Output Signal                        | Pn5B8 (25B8h) |
| /PM           | Preventative Maintenance Output Signal    | Pn5BC (25BCh) |

### ◆ Relationship between Parameter Settings, Allocated Pins, and Polarities

This section shows the relationship between the output signal parameter settings, the pins on the I/O signal connector (CN1), and the polarities using Pn5B0 (/COIN (Positioning Completion Output) Signal Allocation) as an example. Refer to the following section for information on individual output signals.

 16.1.2 List of Parameters on page 16-3

#### • Relationship between Parameter Settings and Pin Numbers

| Parameter        | Description                 | When Enabled  | Classification |
|------------------|-----------------------------|---------------|----------------|
| Pn5B0<br>(25B0h) | n.□□□□<br>(default setting) | After restart | Setup          |
|                  | n.□□□□*                     |               |                |
|                  | n.□□□□*                     |               |                |
|                  | n.□□□□*                     |               |                |
|                  | n.□□□□*                     |               |                |
|                  | n.□□□□*                     |               |                |

\* If Pn5B0 is set to n.1□□□□ (Output the signal) or n.2□□□□ (Invert the signal and output it) and Pn5B0 is not set to any of these values, an A.040 alarm (Parameter Setting Error) will occur.

#### • Relationship between Parameter Settings and Polarities

| Parameter        | Description                 | When Enabled  | Classification |
|------------------|-----------------------------|---------------|----------------|
| Pn5B0<br>(25B0h) | n.0□□□<br>(default setting) | After restart | Setup          |
|                  | n.1□□□                      |               |                |
|                  | n.2□□□                      |               |                |

## Confirming the Allocation Status of Output Signals

You can confirm the allocation status of output signals with the I/O Signal Allocation Window of the SigmaWin+. Refer to the following section for details.

 10.2.3 I/O Signals Status Monitor on page 10-5

## 7.1.3 ALM (Servo Alarm) Signal

This signal is output when the SERVOPACK detects an error.



Configure an external circuit so that this alarm output turns OFF the main circuit power supply to the SERVOPACK whenever an error occurs.

| Type   | Signal | Connector Pin No.              | Signal Status | Meaning                 |
|--------|--------|--------------------------------|---------------|-------------------------|
| Output | ALM    | Axis A: CN1-3<br>Axis B: CN1-4 | ON (closed)   | Normal SERVOPACK status |
|        |        |                                | OFF (open)    | SERVOPACK alarm         |

### Alarm Reset Methods

Refer to the following section for information on the alarm reset methods.

15.2.3 Resetting Alarms on page 15-41

## 7.1.4 /WARN (Warning) Signal

Both alarms and warnings are generated by the SERVOPACK. Alarms indicate errors in the SERVOPACK for which operation must be stopped immediately. Warnings indicate situations that may result in alarms but for which stopping operation is not yet necessary.

The /WARN (Warning) signal indicates that a condition exists that may result in an alarm.

| Type   | Signal | Connector Pin No.  | Signal Status | Meaning       |
|--------|--------|--------------------|---------------|---------------|
| Output | /WARN  | Must be allocated. | ON (closed)   | Warning       |
|        |        |                    | OFF (open)    | Normal status |

Note: You must allocate the /WARN signal to use it. The parameters that you use depend on the allocation method.

| Allocation Method                              | Parameter to Use  |
|--|---|
| $\Sigma$ -7S-Compatible I/O Signal Allocations | <ul style="list-style-type: none"> <li>Pn50A = n.□□□1 (<math>\Sigma</math>-7S-Compatible I/O Signal Allocations)</li> <li>Pn50F = n.X□□□(/WARN (Warning Output) Signal Allocation)</li> </ul> |
| Multi-Axis I/O Signal Allocations              | <ul style="list-style-type: none"> <li>Pn50A = n.□□□2 (Multi-Axis I/O Signal Allocations)</li> <li>Pn5B7 (/WARN (Warning Output) Signal Allocation)</li> </ul>                                |

Refer to the following section for details.

7.1.2 Output Signal Allocations on page 7-7

## 7.1.5 /TGON (Rotation Detection) Signal

The /TGON signal indicates that the Servomotor is operating.

This signal is output when the shaft of the Servomotor rotates at the setting of Pn502 (Rotation Detection Level) or faster or the setting of Pn581 (Zero Speed Level) or faster.

| Type   | Signal | Connector Pin No.  | Signal Status | Servomotor         | Meaning  |
|--------|--------|--------------------|---------------|--------------------|--|
| Output | /TGON  | Must be allocated. | ON (closed)   | Rotary Servomotors | The Servomotor is operating at the setting of Pn502 or faster.                   |
|        |        |                    |               | Linear Servomotors | The Servomotor is operating at the setting of Pn581 or faster.                   |
|        |        |                    | OFF (open)    | Rotary Servomotors | The Servomotor is operating at a speed that is slower than the setting of Pn502. |
|        |        |                    |               | Linear Servomotors | The Servomotor is operating at a speed that is slower than the setting of Pn581. |

Note: You must allocate the /TGON signal to use it. The parameters that you use depend on the allocation method.

| Allocation Method                              | Parameter to Use  |
|--|---|
| $\Sigma$ -7S-Compatible I/O Signal Allocations | <ul style="list-style-type: none"> <li>Pn50A = n.□□□1 (<math>\Sigma</math>-7S-Compatible I/O Signal Allocations)</li> <li>Pn50E = n.□X□□ (/TGON (Rotation Detection Output) Signal Allocation)</li> </ul> |
| Multi-Axis I/O Signal Allocations              | <ul style="list-style-type: none"> <li>Pn50A = n.□□□2 (Multi-Axis I/O Signal Allocations)</li> <li>Pn5B2 (/TGON (Rotation Detection Output) Signal Allocation)</li> </ul>                                 |

Refer to the following section for details.

 [7.1.2 Output Signal Allocations on page 7-7](#)

### Setting the Rotation Detection Level

Use the following parameter to set the speed detection level at which to output the /TGON signal.

- Rotary Servomotors

| Pn502<br>(2502h) | Rotation Detection Level |                     |                 |              | Speed          | Position | Torque |
|------------------|--------------------------|---------------------|-----------------|--------------|----------------|----------|--------|
|                  | Setting Range            | Setting Unit        | Default Setting | When Enabled | Classification |          |        |
|                  | 1 to 10,000              | 1 min <sup>-1</sup> | 20              | Immediately  | Setup          |          |        |

- Linear Servomotors

| Pn581<br>(2581h) | Zero Speed Level |              |                 |              | Speed          | Position | Force |
|------------------|------------------|--------------|-----------------|--------------|----------------|----------|-------|
|                  | Setting Range    | Setting Unit | Default Setting | When Enabled | Classification |          |       |
|                  | 1 to 10,000      | 1 mm/s       | 20              | Immediately  | Setup          |          |       |

## 7.1.6 /S-RDY (Servo Ready) Signal

The /S-RDY (Servo Ready) signal turns ON when the SERVOPACK is ready to accept the servo ON (Enable Operation) command.

The /S-RDY signal is turned ON under the following conditions.

- Main circuit power supply is ON.
- There are no alarms.
- There is no forced stop state (FSTP).
- If a Servomotor without a polarity sensor is used, polarity detection has been completed.\*

\* Do not include this condition if the servo ON (Enable Operation) command is input for the first time after the control power supply was turned ON. In that case, when the first Enable Operation command is input, polarity detection is started immediately and the /S-RDY signal turns ON at the completion of polarity detection.

| Type   | Signal | Connector Pin No.  | Signal Status | Meaning   |
|--------|--------|--------------------|---------------|---|
| Output | /S-RDY | Must be allocated. | ON (closed)   | Ready to receive Servo ON (Enable Operation) command.     |
|        |        |                    | OFF (open)    | Not ready to receive Servo ON (Enable Operation) command. |

Note: You must allocate the /S-RDY signal to use it. The parameters that you use depend on the allocation method.

| Allocation Method                              | Parameter to Use   |
|--|--|
| $\Sigma$ -7S-Compatible I/O Signal Allocations | <ul style="list-style-type: none"> <li>• Pn50A = n.□□□1 (<math>\Sigma</math>-7S-Compatible I/O Signal Allocations)</li> <li>• Pn50E = n.X□□□ (/S-RDY (Servo Ready) Signal Allocation)</li> </ul> |
| Multi-Axis I/O Signal Allocations              | <ul style="list-style-type: none"> <li>• Pn50A = n.□□□2 (Multi-Axis I/O Signal Allocations)</li> <li>• Pn5B3 (/S-RDY (Servo Ready) Signal Allocation)</li> </ul>                                 |

Refer to the following section for details.

 7.1.2 Output Signal Allocations on page 7-7

## 7.1.7 /V-CMP (Speed Coincidence Detection) Signal

The /V-CMP (Speed Coincidence Detection Output) signal is output when the Servomotor speed is the same as the reference speed. This signal is used, for example, to interlock the SERVOPACK and the host controller. You can use this output signal only during speed control.

The /V-CMP signal is described in the following table.

| Type   | Signal | Connector Pin No.  | Signal Status | Meaning                      |
|--------|--------|--------------------|---------------|------------------------------|
| Output | /V-CMP | Must be allocated. | ON (closed)   | The speed coincides.         |
|        |        |                    | OFF (open)    | The speed does not coincide. |

Note: You must allocate the /V-CMP signal to use it. The parameters that you use depend on the allocation method.

| Allocation Method                              | Parameter to Use  |
|--|---|
| $\Sigma$ -7S-Compatible I/O Signal Allocations | <ul style="list-style-type: none"> <li>• Pn50A = n.□□□1 (<math>\Sigma</math>-7S-Compatible I/O Signal Allocations)</li> <li>• Pn50E = n.□□X□ (/V-CMP (Speed Coincidence Detection Output) Signal Allocation)</li> </ul> |
| Multi-Axis I/O Signal Allocations              | <ul style="list-style-type: none"> <li>• Pn50A = n.□□□2 (Multi-Axis I/O Signal Allocations)</li> <li>• Pn5B1 (/V-CMP (Speed Coincidence Detection Output) Signal Allocation)</li> </ul>                                 |

Refer to the following section for details.

 7.1.2 Output Signal Allocations on page 7-7

You can set the speed detection width for the /V-CMP signal in Pn503 (Speed Coincidence Detection Signal Output Width) for a Rotary Servomotor or in Pn582 (Speed Coincidence Detection Signal Output Width) for a Linear Servomotor.

- Rotary Servomotors

| Pn503<br>(2503h) | Speed Coincidence Detection Signal Output Width |                     |                 |              | Speed          |
|------------------|---|---------------------|-----------------|--------------|----------------|
|                  | Setting Range                                   | Setting Unit        | Default Setting | When Enabled | Classification |
|                  | 0 to 100  | 1 min <sup>-1</sup> | 10              | Immediately  | Setup          |

The signal is output when the difference between the reference speed and motor speed is equal or less than the setting.

**Example** If Pn503 is set to 100 and the speed reference is 2,000 min<sup>-1</sup>, the signal would be output when the motor speed is between 1,900 and 2,100 min<sup>-1</sup>.

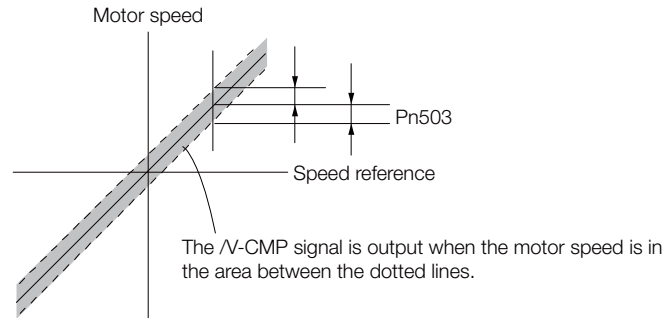

- Linear Servomotors

| Pn582<br>(2582h) | Speed Coincidence Detection Signal Output Width |              |                 |              | Speed          |
|------------------|---|--------------|-----------------|--------------|----------------|
|                  | Setting Range                                   | Setting Unit | Default Setting | When Enabled | Classification |
|                  | 0 to 100  | 1 mm/s       | 10              | Immediately  | Setup          |

The signal is output when the difference between the reference speed and motor speed is equal or less than the setting.

**Example** If Pn582 is set to 100 and the speed reference is 2,000 mm/s the signal would be output when the motor speed is between 1,900 and 2,100 mm/s.

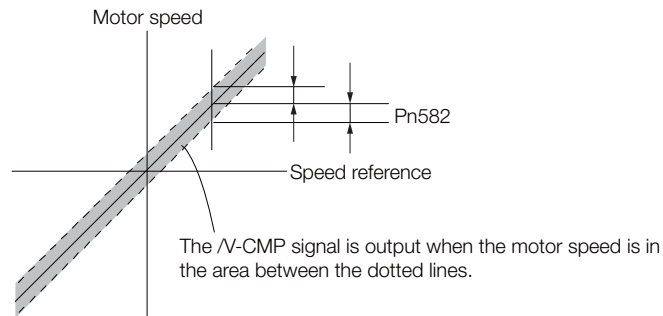

## 7.1.8 /COIN (Positioning Completion) Signal

The /COIN (Positioning Completion) signal indicates that Servomotor positioning has been completed during position control.

The /COIN signal is output when the difference between the reference position output by the host controller and the current position of the Servomotor (i.e., the position deviation as given by the value of the deviation counter) is equal to or less than the setting of the positioning completed width (Pn522).

Use this signal to check the completion of positioning from the host controller.

| Type   | Signal | Connector Pin No.  | Signal Status | Meaning                             |
|--------|--------|--------------------|---------------|-------------------------------------|
| Output | /COIN  | Must be allocated. | ON (closed)   | Positioning has been completed.     |
|        |        |                    | OFF (open)    | Positioning has not been completed. |

Note: You must allocate the /COIN signal to use it. The parameters that you use depend on the allocation method.

| Allocation Method                      | Parameter to Use  |
|--|---|
| Σ-7S-Compatible I/O Signal Allocations | <ul style="list-style-type: none"> <li>Pn50A = n.□□□1 (Σ-7S-Compatible I/O Signal Allocations)</li> <li>Pn50E = n.□□□X (/COIN (Positioning Completion Output) Signal Allocation)</li> </ul> |
| Multi-Axis I/O Signal Allocations      | <ul style="list-style-type: none"> <li>Pn50A = n.□□□2 (Multi-Axis I/O Signal Allocations)</li> <li>Pn5B0 (/COIN (Positioning Completion Output) Signal Allocation)</li> </ul>               |

Refer to the following section for details.

 7.1.2 Output Signal Allocations on page 7-7

### Setting the Positioning Completed Width

The /COIN signal is output when the difference between the reference position and the current position (i.e., the position deviation as given by the value of the deviation counter) is equal to or less than the setting of the positioning completed width (Pn522).

| Pn522 (2522h) | Positioning Completed Width |                  |                 |              | Position       |
|---------------|-----------------------------|------------------|-----------------|--------------|----------------|
|               | Setting Range               | Setting Unit     | Default Setting | When Enabled | Classification |
|               | 0 to 1,073,741,824          | 1 reference unit | 7               | Immediately  | Setup          |

The setting of the positioning completed width has no effect on final positioning accuracy.

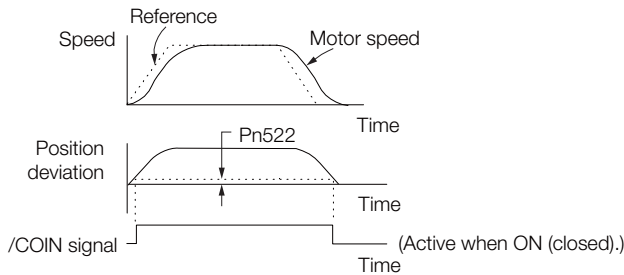

Note: If the parameter is set to a value that is too large, the /COIN signal may be output when the position deviation is low during a low-speed operation. If that occurs, reduce the setting until the signal is no longer output.

## Setting the Output Timing of the /COIN (Positioning Completion Output) Signal

You can add a reference input condition to the output conditions for the /COIN signal to change the signal output timing.

If the position deviation is always low and a narrow positioning completed width is used, change the setting of Pn207 = n.X□□□ (/COIN (Positioning Completion Output) Signal Output Timing) to change output timing for the /COIN signal.

| Parameter        |                             | Description   | When Enabled  | Classification |
|------------------|-----------------------------|---|---------------|----------------|
| Pn207<br>(2207h) | n.0□□□<br>(default setting) | Output the /COIN signal when the absolute value of the position deviation is the same or less than the setting of Pn522 (Positioning Completed Width).  | After restart | Setup          |
|                  | n. 1□□□                     | Output the /COIN signal when the absolute value of the position deviation is the same or less than the setting of Pn522 (Positioning Completed Width) and the reference after the position reference filter is 0. |               |                |
|                  | n. 2□□□                     | Output the /COIN signal when the absolute value of the position deviation is the same or less than the setting of Pn522 (Positioning Completed Width) and the reference input is 0.                               |               |                |

## 7.1.9 /NEAR (Near) Signal

The /NEAR (Near) signal indicates when positioning completion is being approached.

The host controller receives the NEAR signal before it receives the /COIN (Positioning Completion) signal, it can start preparations for the operating sequence to use after positioning has been completed. This allows you to reduce the time required for operation when positioning is completed.

The NEAR signal is generally used in combination with the /COIN signal.

| Type   | Signal | Connector Pin No.  | Signal Status | Meaning  |
|--------|--------|--------------------|---------------|--|
| Output | /NEAR  | Must be allocated. | ON (closed)   | The Servomotor has reached a point near to positioning completion.     |
|        |        |                    | OFF (open)    | The Servomotor has not reached a point near to positioning completion. |

Note: You must allocate the /NEAR signal to use it. The parameters that you use depend on the allocation method.

| Allocation Method                      | Parameter to Use  |
|--|---|
| Σ-7S-Compatible I/O Signal Allocations | <ul style="list-style-type: none"> <li>• Pn50A = n.□□□1 (Σ-7S-Compatible I/O Signal Allocations)</li> <li>• Pn510 = n.□□□X (/NEAR (Near Output) Signal Allocation)</li> </ul> |
| Multi-Axis I/O Signal Allocations      | <ul style="list-style-type: none"> <li>• Pn50A = n.□□□2 (Multi-Axis I/O Signal Allocations)</li> <li>• Pn5B8 (/NEAR (Near Output) Signal Allocation)</li> </ul>               |

Refer to the following section for details.

 [7.1.2 Output Signal Allocations on page 7-7](#)

## /NEAR (Near) Signal Setting

You set the condition for outputting the /NEAR (Near) signal (i.e., the near signal width) in Pn524 (Near Signal Width). The /NEAR signal is output when the difference between the reference position and the current position (i.e., the position deviation as given by the value of the deviation counter) is equal to or less than the setting of the near signal width (Pn524).

| Pn524<br>(2524h) | Near Signal Width <span style="float: right;">Position</span> |                  |                 |              |                |
|------------------|---|------------------|-----------------|--------------|----------------|
|                  | Setting Range   | Setting Unit     | Default Setting | When Enabled | Classification |
|                  | 1 to 1,073,741,824  | 1 reference unit | 1,073,741,824   | Immediately  | Setup          |

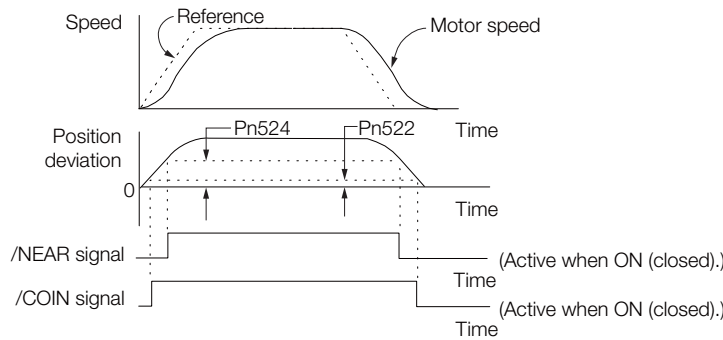

Note: Normally, set Pn524 to a value that is larger than the setting of Pn522 (Positioning Completed Width).

## 7.1.10 Speed Limit during Torque Control

You can limit the speed of the Servomotor to protect the machine.

When you use a Servomotor for torque control, the Servomotor is controlled to output the specified torque, but the motor speed is not controlled. Therefore, if a reference torque is input that is larger than the machine torque, the speed of the Servomotor may increase greatly. If that may occur, use this function to limit the speed.

Note: The actual limit of motor speed depends on the load conditions on the Servomotor.

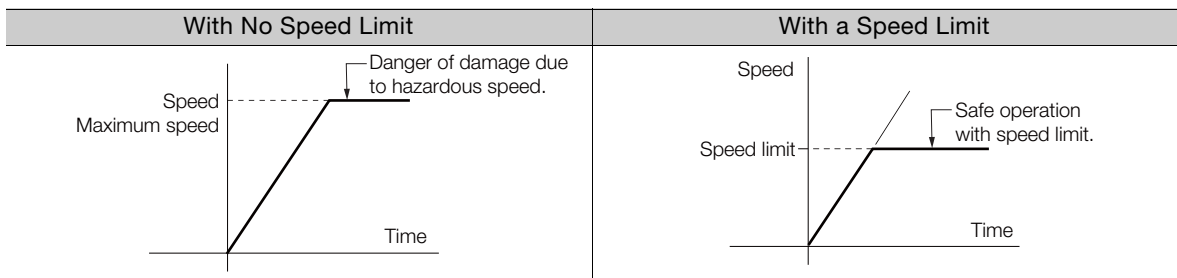

## /VLT (Speed Limit Detection) Signal

The signal that is output when the motor speed is being limited by the speed limit is described in the following table.

| Type   | Signal | Connector Pin No.  | Signal Status | Meaning                                    |
|--------|--------|--------------------|---------------|--|
| Output | /VLT   | Must be allocated. | ON (closed)   | The Servomotor speed is being limited.     |
|        |        |                    | OFF (open)    | The Servomotor speed is not being limited. |

Note: You must allocate the /VLT signal to use it. The parameters that you use depend on the allocation method.

| Allocation Method                      | Parameter to Use   |
|--|--|
| Σ-7S-Compatible I/O Signal Allocations | <ul style="list-style-type: none"> <li>Pn50A = n.□□□1 (Σ-7S-Compatible I/O Signal Allocations)</li> <li>Pn50F = n.□□X□ (/VLT (Speed Limit Detection) Signal Allocation)</li> </ul> |
| Multi-Axis I/O Signal Allocations      | <ul style="list-style-type: none"> <li>Pn50A = n.□□□2 (Multi-Axis I/O Signal Allocations)</li> <li>Pn5B5 (/VLT (Speed Limit Detection) Signal Allocation)</li> </ul>               |

Refer to the following section for details.

7.1.2 Output Signal Allocations on page 7-7



## Internal Speed Limiting

Set the speed limit for the motor in Pn407 (Speed Limit during Torque Control) or Pn480 (Speed Limit during Force Control). Also set Pn408 = n.□□X□ (Speed Limit Selection) to specify using the maximum motor speed or the overspeed alarm detection speed as the speed limit. Select the overspeed alarm detection speed to limit the speed to the equivalent of the maximum motor speed.

| Parameter        | Meaning                     | When Enabled  | Classification |
|------------------|-----------------------------|---------------|----------------|
| Pn408<br>(2408h) | n.□□0□<br>(default setting) | After restart | Setup          |
|                  | n.□□1□                      |               |                |

Note: If you are using a Rotary Servomotor, set Pn407 (Speed Limit during Torque Control). If you are using a Linear Servomotor, set Pn480 (Speed Limit during Force Control).

- Rotary Servomotors

| Pn407<br>(2407h) | Speed Limit during Torque Control <span style="float: right;">Torque</span> |                     |                 |              |                |
|------------------|---|---------------------|-----------------|--------------|----------------|
|                  | Setting Range   | Setting Unit        | Default Setting | When Enabled | Classification |
|                  | 0 to 10,000   | 1 min <sup>-1</sup> | 10000           | Immediately  | Setup          |

- Linear Servomotors

| Pn480<br>(2480h) | Speed Limit during Force Control <span style="float: right;">Force</span> |              |                 |              |                |
|------------------|---|--------------|-----------------|--------------|----------------|
|                  | Setting Range   | Setting Unit | Default Setting | When Enabled | Classification |
|                  | 0 to 10,000   | 1 mm/s       | 10000           | Immediately  | Setup          |

Note: If the parameter setting exceeds the maximum speed of the Servomotor, the Servomotor's maximum speed or the overspeed alarm detection speed will be used.

# 7.2 Operation for Momentary Power Interruptions

Even if the main power supply to the SERVOPACK is interrupted momentarily, power supply to the motor (servo ON status) will be maintained for the time set in Pn509 (Momentary Power Interruption Hold Time).

| Pn509<br>(2509h) | Momentary Power Interruption Hold Time |              |                 | Speed        | Position       | Torque |
|------------------|--|--------------|-----------------|--------------|----------------|--------|
|                  | Setting Range                          | Setting Unit | Default Setting | When Enabled | Classification |        |
| Common           | 20 to 50,000                           | 1 ms         | 20              | Immediately  | Setup          |        |

If the momentary power interruption time is equal to or less than the setting of Pn509, power supply to the motor will be continued. If it is longer than the setting, power supply to the motor will be stopped. Power will be supplied to the motor again when the main circuit power supply recovers.

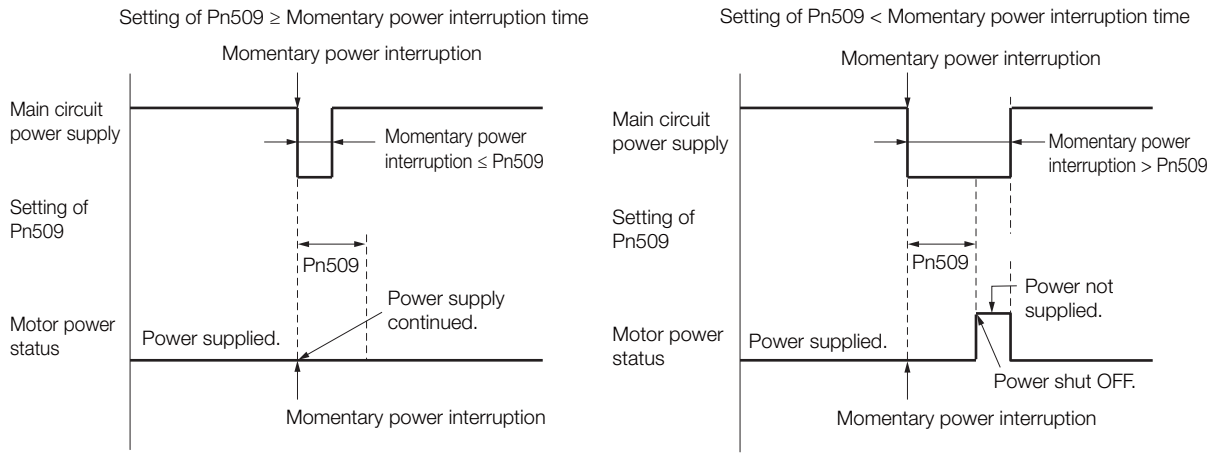

**Information**

1. If the momentary power interruption time exceeds the setting of Pn509, the /S-RDY (Servo Ready) signal will turn OFF.
2. If uninterruptible power supplies are used for the control power supply and main circuit power supply, the SERVOPACK can withstand a power interruption that lasts longer than 50,000 ms.
3. The holding time of the SERVOPACK control power supply is approximately 100 ms. If control operations become impossible during a momentary power interruption of the control power supply, the setting of Pn509 will be ignored and the same operation will be performed as for when the power supply is turned OFF normally.



Important

The holding time of the main circuit power supply depends on the output from the SERVOPACK. If the load on the Servomotor is large and an A.410 alarm (Undervoltage) occurs, the setting of Pn509 will be ignored.

## 7.3 SEMI F47 Function

The SEMI F47 function detects an A.971 warning (Undervoltage) and limits the output current if the DC main circuit power supply voltage to the SERVOPACK drops to a specified value or lower because the power was momentarily interrupted or the main circuit power supply voltage was temporarily reduced.

This function complies with the SEMI F47 standards for semiconductor manufacturing equipment.

You can combine this function with the momentary power interruption hold time (Pn509) to allow the Servomotor to continue operating without stopping for an alarm or without recovery work even if the power supply voltage drops.

### Execution Sequence

This function can be executed either with the host controller or with the SERVOPACK. Use Pn008 = n.□□X□ (Function Selection for Undervoltage) to specify whether the function is executed by the host controller or by the SERVOPACK.

#### ◆ Execution with the Host Controller (Pn008 = n.□□1□)

The host controller limits the torque in response to an A.971 warning (Undervoltage).

The host controller removes the torque limit after the Undervoltage warning is cleared.

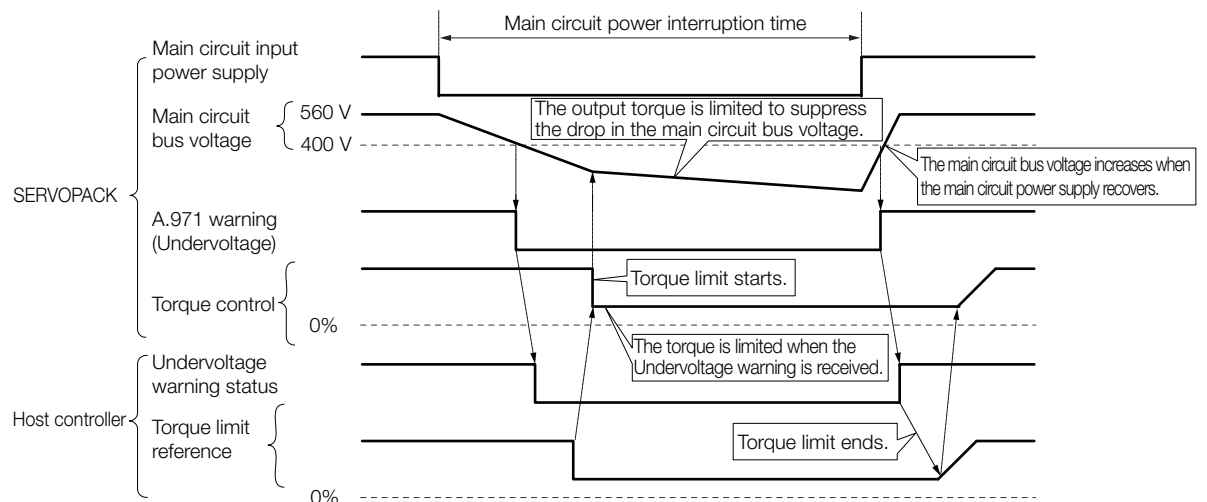

#### ◆ Execution with the SERVOPACK (Pn008 = n.□□2□)

The torque is limited in the SERVOPACK in response to an Undervoltage warning.

The SERVOPACK controls the torque limit for the set time after the Undervoltage warning is cleared.

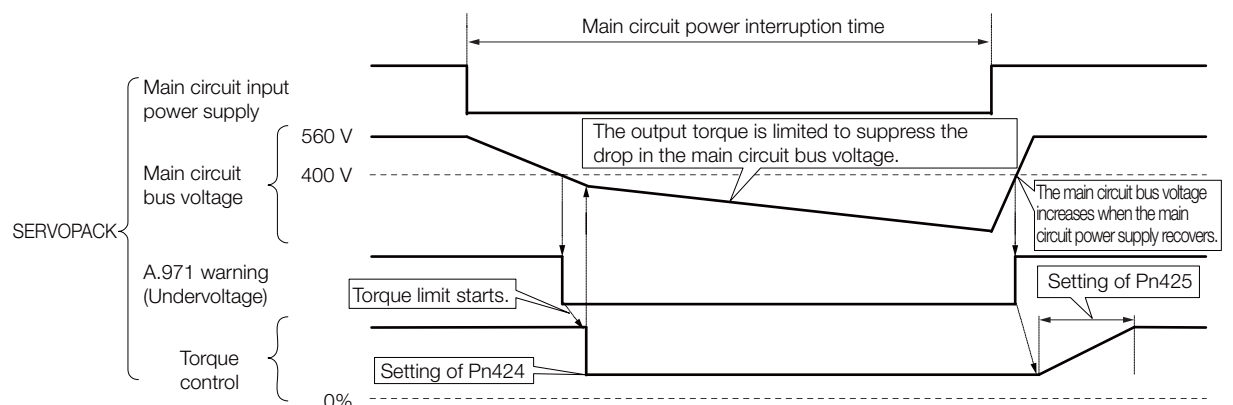

## Setting for A.971 Warnings (Undervoltage)

You can set whether or not to detect A.971 warnings (Undervoltage).

| Parameter        |                             | Meaning  | When Enabled  | Classification |
|------------------|-----------------------------|--|---------------|----------------|
| Pn008<br>(2008h) | n.□□0□<br>(default setting) | Do not detect undervoltage warning.  | After restart | Setup          |
|                  | n.□□1□                      | Detect undervoltage warning and limit torque at host controller.                             |               |                |
|                  | n.□□2□                      | Detect undervoltage warning and limit torque with Pn424 and Pn425 (i.e., only in SERVOPACK). |               |                |

### ◆ Related Parameters

The following parameters are related to the SEMI F47 function.

|                  |  |              |                 |              |                |        |
|------------------|--|--------------|-----------------|--------------|----------------|--------|
| Pn424<br>(2424h) | Torque Limit at Main Circuit Voltage Drop                  |              |                 | Speed        | Position       | Torque |
|                  | Setting Range  | Setting Unit | Default Setting | When Enabled | Classification |        |
|                  | 0 to 100   | 1%*          | 50              | Immediately  | Setup          |        |
| Pn425<br>(2425h) | Release Time for Torque Limit at Main Circuit Voltage Drop |              |                 | Speed        | Position       | Torque |
|                  | Setting Range  | Setting Unit | Default Setting | When Enabled | Classification |        |
|                  | 0 to 1,000   | 1 ms         | 100             | Immediately  | Setup          |        |
| Pn509<br>(2509h) | Momentary Power Interruption Hold Time                     |              |                 | Speed        | Position       | Torque |
|                  | Setting Range  | Setting Unit | Default Setting | When Enabled | Classification |        |
|                  | Common   | 20 to 50,000 | 1 ms            | 20           | Immediately    | Setup  |

\* Set a percentage of the motor rated torque.

Note: If you will use the SEMI F47 function, set the time to 1,000 ms.



Important

- This function handles momentary power interruptions for the voltage and time ranges stipulated in SEMI F47. An uninterruptible power supply (UPS) is required as a backup for momentary power interruptions that exceed these voltage and time ranges.
- Set the host controller or SERVOPACK torque limit so that a torque reference that exceeds the specified acceleration torque will not be output when the power supply for the main circuit is restored.
- For a vertical axis, do not limit the torque to a value that is lower than the holding torque.
- This function limits torque within the range of the SERVOPACK's capability for power interruptions. It is not intended for use under all load and operating conditions. Set the parameters while monitoring operation on the actual machine.
- You can set the momentary power interruption hold time to increase the amount of time from when the power supply is turned OFF until power supply to the motor is stopped. To stop the power supply to the motor immediately, use the SV\_OFF (Servo OFF) command.

## 7.4

## Setting the Motor Maximum Speed

You can set the maximum speed of the Servomotor with the following parameter.

- Rotary Servomotors

| Pn316<br>(2316h) | Maximum Motor Speed |                     |                 |               |                |        |
|------------------|---------------------|---------------------|-----------------|---------------|----------------|--------|
|                  |                     |                     |                 | Speed         | Position       | Torque |
|                  | Setting Range       | Setting Unit        | Default Setting | When Enabled  | Classification |        |
|                  | 0 to 65,535         | 1 min <sup>-1</sup> | 10,000          | After restart | Setup          |        |

- Linear Servomotors

| Pn385<br>(2385h) | Maximum Motor Speed |              |                 |               |                |       |
|------------------|---------------------|--------------|-----------------|---------------|----------------|-------|
|                  |                     |              |                 | Speed         | Position       | Force |
|                  | Setting Range       | Setting Unit | Default Setting | When Enabled  | Classification |       |
|                  | 1 to 100            | 100 mm/s     | 50              | After restart | Setup          |       |

You can achieve the following by lowering the maximum speed of the Servomotor.

- If the motor speed exceeds the setting, an A.510 alarm (Overspeed) will occur.

Changing the setting of the parameter is effective in the following cases.

- To protect the machine by stopping machine operation with an alarm when the set speed is reached or exceeded
- To limit the speed so that the load is driven beyond the allowable moment of inertia  
Refer to relevant manual from the following list for the relationship between the speed and the allowable moment of inertia.

📖  $\Sigma$ -7-Series Rotary Servomotor with 400 V-Input Power Product Manual (Manual No.: SIEP S800001 86)

📖  $\Sigma$ -7-Series Linear Servomotor with 400 V-Input Power Product Manual (Manual No.: SIEP S800001 81)

## 7.5 Software Limits

You can set limits in the software for machine movement that do not use the overtravel signals (P-OT and N-OT). If a software limit is exceeded, an emergency stop will be executed in the same way as it is for overtravel.

Refer to the following section for details on this function.

 *Software Position Limits (A: 607Dh, B: 687Dh)* on page 14-36

## 7.6 Selecting Torque Limits

You can limit the torque that is output by the Servomotor.

There are four different ways to limit the torque. These are described in the following table.

| Limit Method   | Outline  | Control Method                                     | Reference |
|--|--|--|-----------|
| Internal Torque Limits   | The torque is always limited with the setting of a parameter.                      | Speed control, position control, or torque control | 7.6.1     |
| External Torque Limits   | The torque is limited with an input signal from the host computer.                 |  | 7.6.2     |
| Limiting Torque with <i>control word</i> (6040h)   | A command from the Controller enables the torque limit that is set in a parameter. | Speed control or position control                  | 14.7      |
| Limiting Torque with <i>positive torque limit value</i> (60E0h) and <i>negative torque limit value</i> (60E1h) | Torque is controlled with torque limits from the Controller.                       |  | 13.7      |

Note: If you set a value that exceeds the maximum torque of the Servomotor, the torque will be limited to the maximum torque of the Servomotor.

### 7.6.1 Internal Torque Limits

If you use internal torque limits, the maximum output torque will always be limited to the specified forward torque limit (Pn402) and reverse torque limit (Pn403).

- Rotary Servomotors

|                  |                      |              |                 |              |                                |                                   |                                 |
|------------------|----------------------|--------------|-----------------|--------------|--------------------------------|-----------------------------------|---------------------------------|
| Pn402<br>(2402h) | Forward Torque Limit |              |                 |              | <input type="checkbox"/> Speed | <input type="checkbox"/> Position | <input type="checkbox"/> Torque |
|                  | Setting Range        | Setting Unit | Default Setting | When Enabled | Classification                 |                                   |                                 |
|                  | 0 to 800             | 1%*          | 800             | Immediately  | Setup                          |                                   |                                 |
| Pn403<br>(2403h) | Reverse Torque Limit |              |                 |              | <input type="checkbox"/> Speed | <input type="checkbox"/> Position | <input type="checkbox"/> Torque |
|                  | Setting Range        | Setting Unit | Default Setting | When Enabled | Classification                 |                                   |                                 |
|                  | 0 to 800             | 1%*          | 800             | Immediately  | Setup                          |                                   |                                 |

\* Set a percentage of the rated motor torque.

Note: If the setting of Pn402 or Pn403 is too low, the torque may be insufficient for acceleration or deceleration of the Servomotor.

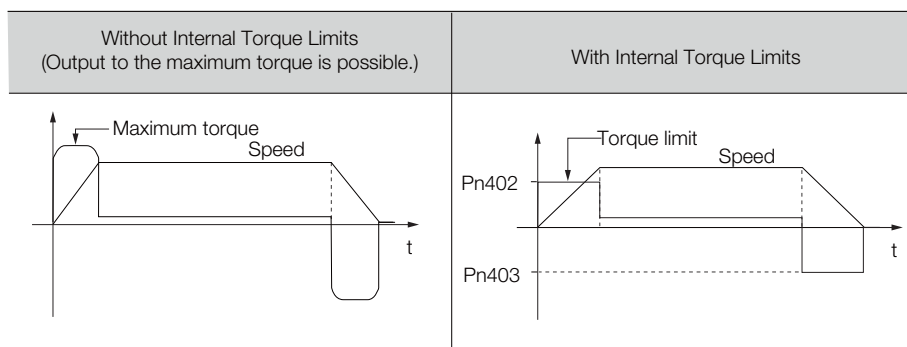

- Linear Servomotors

|                  |                     |              |                 |              |                |       |
|------------------|---------------------|--------------|-----------------|--------------|----------------|-------|
| Pn483<br>(2483h) | Forward Force Limit |              |                 | Speed        | Position       | Force |
|                  | Setting Range       | Setting Unit | Default Setting | When Enabled | Classification |       |
|                  | 0 to 800            | 1%*          | 30              | Immediately  | Setup          |       |
| Pn484<br>(2484h) | Reverse Force Limit |              |                 | Speed        | Position       | Force |
|                  | Setting Range       | Setting Unit | Default Setting | When Enabled | Classification |       |
|                  | 0 to 800            | 1%*          | 30              | Immediately  | Setup          |       |

\* Set a percentage of the rated motor force.

Note: If the setting of Pn483 or Pn484 is too low, the force may be insufficient for acceleration or deceleration of the Servomotor.

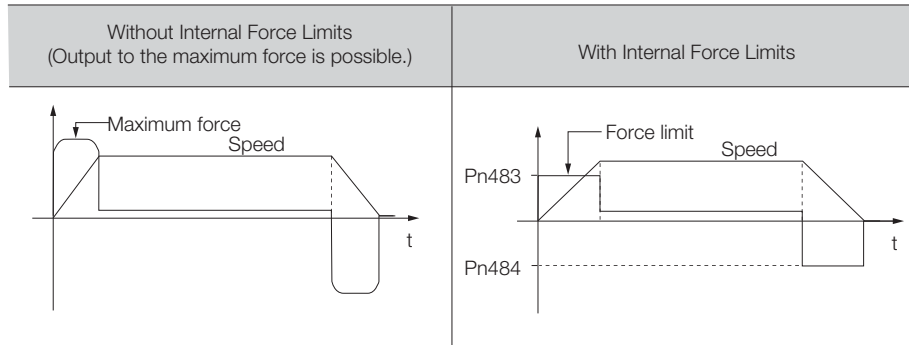

## 7.6.2 External Torque Limits

You can limit the torque only when required by the operating conditions of the machine by turning a signal ON and OFF.

You can use this for applications such as stopping on physical contact, or holding a workpiece with a robot.

### External Torque Limit Reference Signals

The /P-CL (Forward External Torque Limit) and /N-CL (Reverse External Torque Limit) signals are used as the external torque limit reference signals. The /P-CL signal is used for the forward torque limit and the /N-CL signal is used for the reverse torque limit.

| Type  | Signal | Connector Pin No.  | Signal Status | Meaning   |
|-------|--------|--------------------|---------------|---|
| Input | /P-CL  | Must be allocated. | ON (closed)   | Applies the forward external torque limit. The torque is limited to the smaller of the settings of Pn402*1 and Pn404. |
|       |        |                    | OFF (open)    | Cancels the forward external torque limit. The torque is limited to the setting of Pn402*1.                           |
| Input | /N-CL  | Must be allocated. | ON (closed)   | Applies the reverse external torque limit. The torque is limited to the smaller of the settings of Pn403*2 and Pn405. |
|       |        |                    | OFF (open)    | Cancels the reverse external torque limit. The torque is limited to the setting of Pn403*2.                           |

\*1. Pn483 is used for a Linear Servomotor.

\*2. Pn484 is used for a Linear Servomotor.

Note: You must allocate the /P-CL and /N-CL signals to use them. You can use the following parameters to allocate the signal to a terminal.

- Pn50B = n.X□□□ (/P-CL (Forward External Torque Limit Input) Signal Allocation)
- Pn50B = n.X□□□ (/N-CL (Reverse External Torque Limit Input) Signal Allocation)

Refer to the following section for details.

7.1.1 Input Signal Allocations on page 7-4



## Setting the Torque Limits

The parameters that are related to setting the torque limits are given below.

- Rotary Servomotors

If the setting of Pn402 (Forward Torque Limit), Pn403 (Reverse Torque Limit), Pn404 (Forward External Torque Limit), or Pn405 (Reverse External Torque Limit) is too low, the torque may be insufficient for acceleration or deceleration of the Servomotor.

|                  |                               |              |                 |                                |                                   |                                 |
|------------------|-------------------------------|--------------|-----------------|--------------------------------|-----------------------------------|---------------------------------|
| Pn402<br>(2402h) | Forward Torque Limit          |              |                 | <input type="checkbox"/> Speed | <input type="checkbox"/> Position | <input type="checkbox"/> Torque |
|                  | Setting Range                 | Setting Unit | Default Setting | When Enabled                   | Classification                    |                                 |
|                  | 0 to 800                      | 1%*          | 800             | Immediately                    | Setup                             |                                 |
| Pn403<br>(2403h) | Reverse Torque Limit          |              |                 | <input type="checkbox"/> Speed | <input type="checkbox"/> Position | <input type="checkbox"/> Torque |
|                  | Setting Range                 | Setting Unit | Default Setting | When Enabled                   | Classification                    |                                 |
|                  | 0 to 800                      | 1%*          | 800             | Immediately                    | Setup                             |                                 |
| Pn404<br>(2404h) | Forward External Torque Limit |              |                 | <input type="checkbox"/> Speed | <input type="checkbox"/> Position | <input type="checkbox"/> Torque |
|                  | Setting Range                 | Setting Unit | Default Setting | When Enabled                   | Classification                    |                                 |
|                  | 0 to 800                      | 1%*          | 100             | Immediately                    | Setup                             |                                 |
| Pn405<br>(2405h) | Reverse External Torque Limit |              |                 | <input type="checkbox"/> Speed | <input type="checkbox"/> Position | <input type="checkbox"/> Torque |
|                  | Setting Range                 | Setting Unit | Default Setting | When Enabled                   | Classification                    |                                 |
|                  | 0 to 800                      | 1%*          | 100             | Immediately                    | Setup                             |                                 |

\* Set a percentage of the rated motor torque.

- Linear Servomotors

If the setting of Pn483 (Forward Force Limit), Pn484 (Reverse Force Limit), Pn404 (Forward External Force Limit), or Pn405 (Reverse External Force Limit) is too low, the force may be insufficient for acceleration or deceleration of the Servomotor.

|                  |                              |              |                 |                                |                                   |                                |
|------------------|------------------------------|--------------|-----------------|--------------------------------|-----------------------------------|--------------------------------|
| Pn483<br>(2483h) | Forward Force Limit          |              |                 | <input type="checkbox"/> Speed | <input type="checkbox"/> Position | <input type="checkbox"/> Force |
|                  | Setting Range                | Setting Unit | Default Setting | When Enabled                   | Classification                    |                                |
|                  | 0 to 800                     | 1%*          | 30              | Immediately                    | Setup                             |                                |
| Pn484<br>(2484h) | Reverse Force Limit          |              |                 | <input type="checkbox"/> Speed | <input type="checkbox"/> Position | <input type="checkbox"/> Force |
|                  | Setting Range                | Setting Unit | Default Setting | When Enabled                   | Classification                    |                                |
|                  | 0 to 800                     | 1%*          | 30              | Immediately                    | Setup                             |                                |
| Pn404<br>(2404h) | Forward External Force Limit |              |                 | <input type="checkbox"/> Speed | <input type="checkbox"/> Position | <input type="checkbox"/> Force |
|                  | Setting Range                | Setting Unit | Default Setting | When Enabled                   | Classification                    |                                |
|                  | 0 to 800                     | 1%*          | 100             | Immediately                    | Setup                             |                                |
| Pn405<br>(2405h) | Reverse External Force Limit |              |                 | <input type="checkbox"/> Speed | <input type="checkbox"/> Position | <input type="checkbox"/> Force |
|                  | Setting Range                | Setting Unit | Default Setting | When Enabled                   | Classification                    |                                |
|                  | 0 to 800                     | 1%*          | 100             | Immediately                    | Setup                             |                                |

\* Set a percentage of the rated motor force.

## Changes in the Output Torque for External Torque Limits

The following table shows the changes in the output torque when the internal torque limit is set to 800%.

- Rotary Servomotors

It is assumed that counterclockwise is set as the forward direction of motor rotation (Pn000 = n.□□□0).

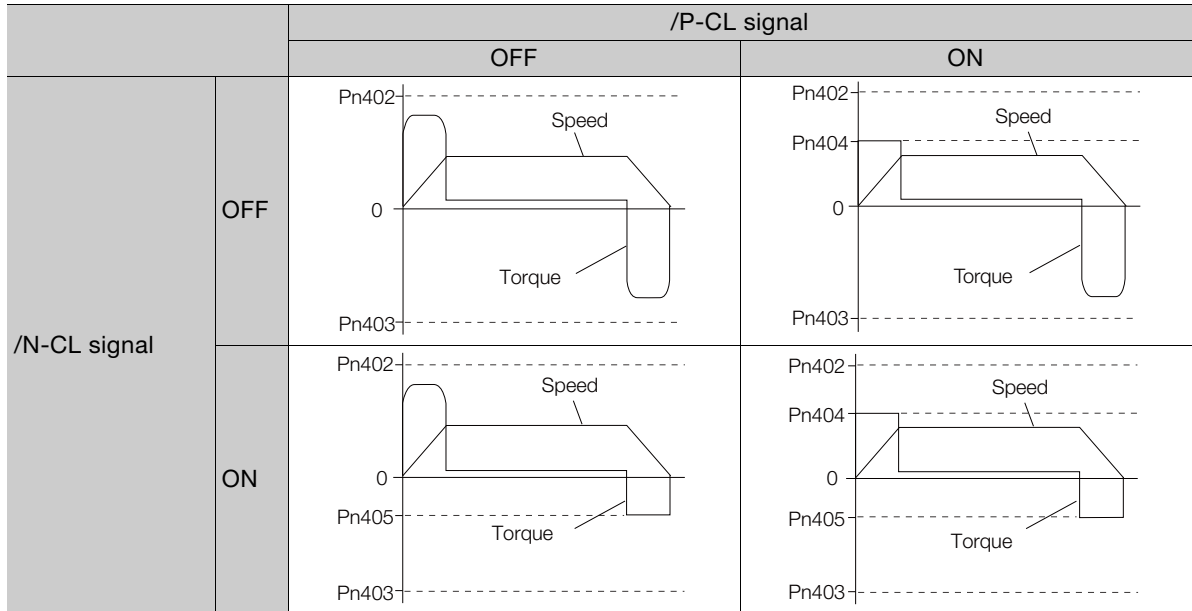

- Linear Servomotors

It is assumed that the linear encoder count-up direction is set as the forward direction of motor movement (Pn000 = n.□□□0).

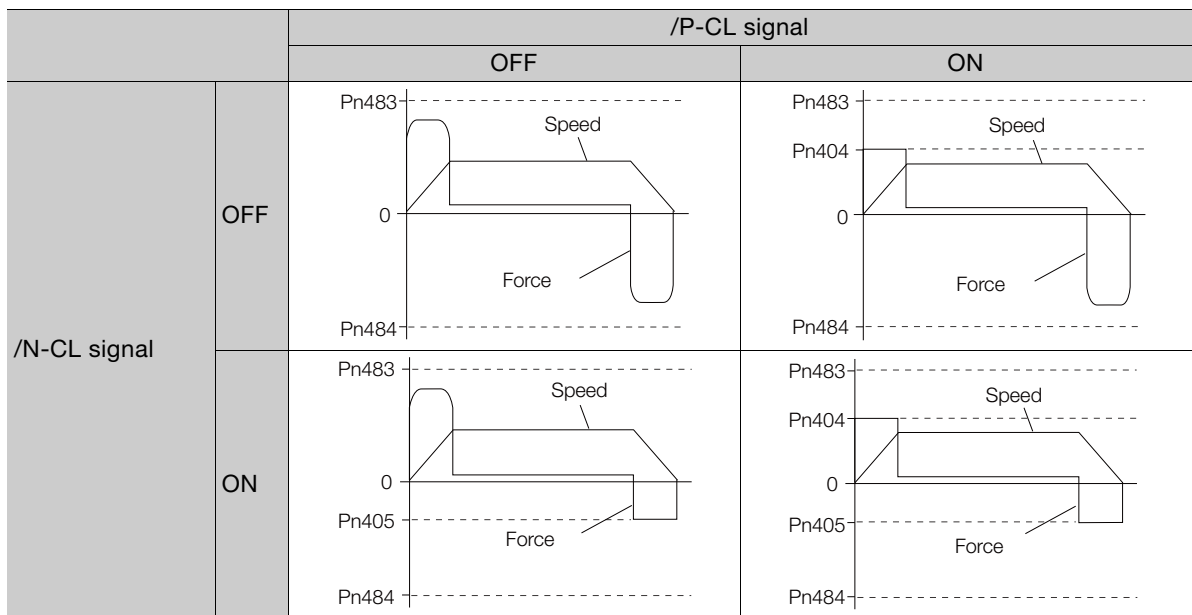

## 7.6.3 /CLT (Torque Limit Detection) Signal

This section describes the /CLT signal, which indicates the status of limiting the motor output torque.

| Type   | Signal | Connector Pin No.  | Signal Status | Meaning                                       |
|--------|--------|--------------------|---------------|---|
| Output | /CLT   | Must be allocated. | ON (closed)   | The motor output torque is being limited.     |
|        |        |                    | OFF (open)    | The motor output torque is not being limited. |

Note: You must allocate the /CLT signal to use it. Use Pn50F = n.□□□X (/CLT (Torque Limit Detection) Signal Allocation) to allocate the signal to a connector pin. Refer to the following section for details.

 [7.1.2 Output Signal Allocations on page 7-7](#)

# 7.7 Absolute Encoders

The absolute encoder records the current position of the stop position even when the power supply is OFF.

With a system that uses an absolute encoder, the host controller can monitor the current position. Therefore, it is not necessary to perform an origin return operation when the power supply to the system is turned ON.

There are two types of encoders for Rotary Servomotors. The usage of the encoder is specified in Pn002 = n.□X□□.

Refer to the following section for encoder models.

 **Encoder Resolution** on page 6-42

• **Parameter Settings When Using an Incremental Encoder**

| Parameter     | Meaning                  | When Enabled  | Classification |
|---------------|--------------------------|---------------|----------------|
| Pn002 (2002h) | n.□0□□ (default setting) | After restart | Setup          |
|               | n.□1□□                   |               |                |
|               | n.□2□□                   |               |                |

• **Parameter Settings When Using a Multiturn Absolute Encoder**

| Parameter     | Meaning                  | When Enabled  | Classification |
|---------------|--------------------------|---------------|----------------|
| Pn002 (2002h) | n.□0□□ (default setting) | After restart | Setup          |
|               | n.□1□□                   |               |                |
|               | n.□2□□                   |               |                |

**NOTICE**

- **Install a battery at either the host controller or on the Encoder Cable.**  
If you install batteries both at the host controller and on the Encoder Cable at the same time, you will create a loop circuit between the batteries, resulting in a risk of damage or burning.

## 7.7.1 Connecting an Absolute Encoder

You can get the position data from the absolute encoder with EtherCAT communications.

Refer to the following section for information on connecting absolute encoders.

 **4.4.3 Wiring the SERVOPACK to the Encoder** on page 4-20

## 7.7.2 Structure of the Position Data of the Absolute Encoder

The position data of the absolute encoder is the position coordinate from the origin of the absolute encoder.

The position data from the absolute encoder contains the following two items.

- The number of rotations from the origin of the encoder coordinate system (called the multiturn data)
- The position (number of pulses) within one rotation

The position data of the absolute encoder is as follows:

Position data of absolute encoder = Multiturn data × Number of pulses within one encoder rotation (encoder resolution) + Position (number of pulses) within one rotation.

For a single-turn absolute encoder, the multiturn data is 0.

## 7.7.3 Multiturn Limit Setting

The multiturn limit is used in position control for a turntable or other rotating body. For example, consider a machine that moves the turntable shown in the following diagram in only one direction.

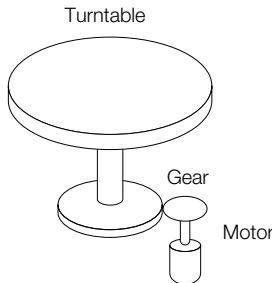

Because the turntable moves in only one direction, the upper limit to the number of rotations that can be counted by an absolute encoder will eventually be exceeded.

The multiturn limit is used in cases like this to prevent fractions from being produced by the integer ratio of the number of motor rotations and the number of turntable rotations.

For a machine with a gear ratio of  $n:m$ , as shown above, the value of  $m$  minus 1 will be the setting for the multiturn limit setting (Pn205).

$$\text{Multiturn limit (Pn205)} = m - 1$$

The relationship between the number of turntable revolutions and the number of motor revolutions is shown in the following graph for when  $m$  is 100 and  $n$  is 3.

Set Pn205 to 99.

$$\text{Pn205} = 100 - 1 = 99$$

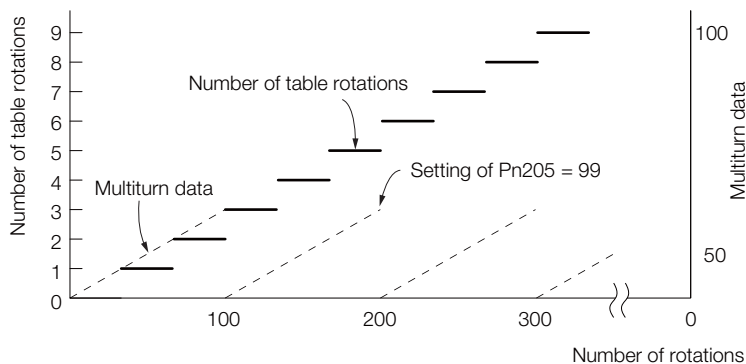

| Pn205<br>(2205h) | Multiturn Limit |              |                 | Speed         | Position       | Torque |
|------------------|-----------------|--------------|-----------------|---------------|----------------|--------|
|                  | Setting Range   | Setting Unit | Default Setting | When Enabled  | Classification |        |
|                  | 0 to 65,535     | 1 Rev        | 65,535          | After restart | Setup          |        |

Note: This parameter is enabled when you use an absolute encoder.

The data will change as shown below when this parameter is set to anything other than the default setting.

- If the motor operates in the reverse direction when the multiturn data is 0, the multiturn data will change to the value set in Pn205.
- If the motor operates in the forward direction when the multiturn data is at the value set in Pn205, the multiturn data will change to 0.

Set Pn205 to one less than the desired multiturn data.

If you change the multiturn limit in Pn205, an A.CC0 alarm (Multiturn Limit Disagreement) will be displayed because the setting disagrees with the value in the encoder. Refer to the following section for the procedure to change the multiturn limit settings in the encoder.

7.7.4 Multiturn Limit Disagreement Alarm (A.CC0) on page 7-31

## 7.7 Absolute Encoders

### 7.7.3 Multiturn Limit Setting

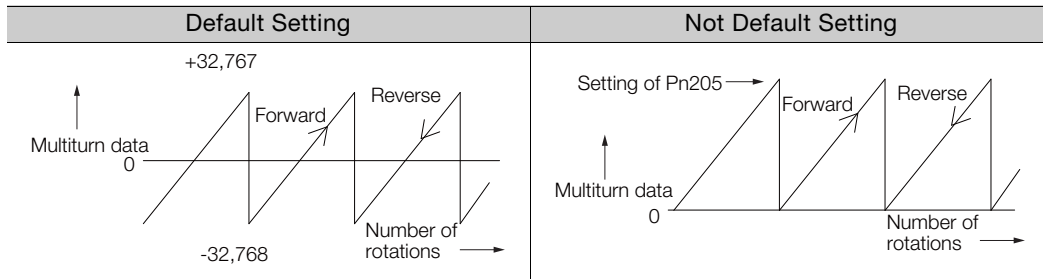

**Information** The multiturn data will always be 0 in the following cases. It is not necessary to reset the absolute encoder in these cases.

- When you use a single-turn absolute encoder
  - When the encoder is set to be used as a single-turn absolute encoder (Pn002 = n.□2□□)
- Absolute encoder-related alarms (A.810 and A.820) will not occur.

## 7.7.4 Multiturn Limit Disagreement Alarm (A.CC0)



If you change the multiturn limit in Pn205 (Multiturn Limit), an A.CC0 alarm (Multiturn Limit Disagreement) will be displayed because the setting disagrees with the value in the encoder.

| Display | Name                         | Meaning  |
|---------|------------------------------|--|
| A.CC0   | Multiturn Limit Disagreement | Different multiturn limits are set in the encoder and SERVOPACK. |

If this alarm is displayed, use the following procedure to change the multiturn limit in the encoder to the same value as the setting of Pn205.

### Applicable Tools

The following table lists the tools that you can use to set the multiturn limit.

| Tool                    | Fn No./Function Name                            | Operating Procedure Reference  |
|-------------------------|---|--|
| Digital Operator        | Fn013   |  $\Sigma$ -7-Series Digital Operator Operating Manual (Manual No.: S1EP S800001 33) |
| SigmaWin+               | <b>Encoder Setting - Multi-turn Limit Setup</b> |  Operating Procedure on page 7-31   |
| EtherCAT communications | SERVOPACK Adjusting Command (2710h)             |  <i>SERVOPACK Adjusting Command (A: 2710h, B: 2F10h)</i> on page 14-24              |

### Operating Procedure

Use the following procedure to adjust the multiturn limit setting.

1. Click the  Servo Drive Button in the workspace of the Main Window of the SigmaWin+.
2. Select **Multiturn Limit Setting** in the Menu Dialog Box.  
The Multiturn Limit Setting Dialog Box will be displayed.
3. Click the **Continue** Button.

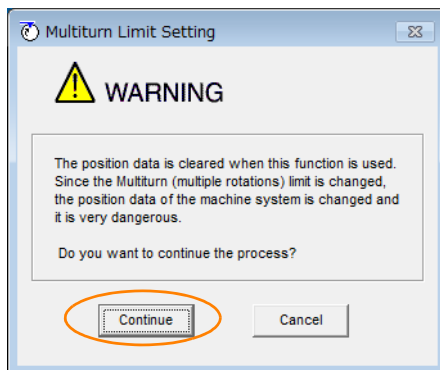

Click the **Cancel** Button to cancel setting the multiturn limit.  
The Main Window will return.

4. Change the setting.

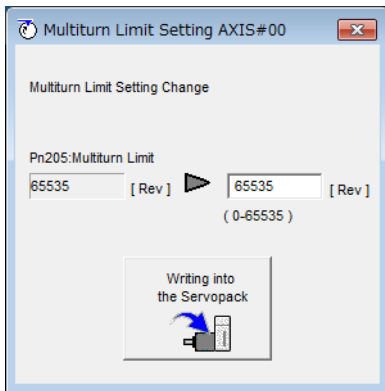

5. Click the **Writing into the Servopack** Button.

6. Click the **OK** Button.

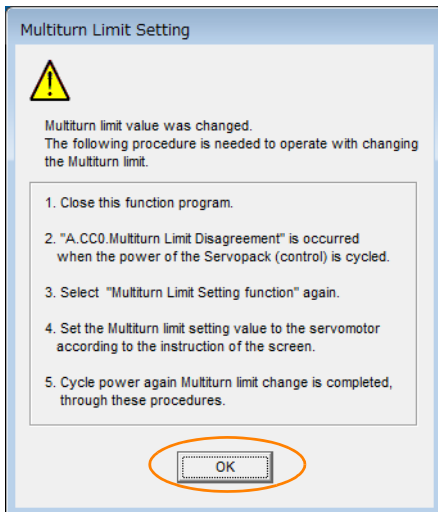

7. Turn the power supply to the **SERVOPACK OFF** and **ON** again.

An A.CC0 alarm (Multiturn Limit Disagreement) will occur because setting the multiturn limit in the Servomotor is not yet completed even though the setting has been changed in the SERVOPACK.

8. Display the Multiturn Limit Setting in the Menu Dialog Box.

9. Click the **Continue** Button.

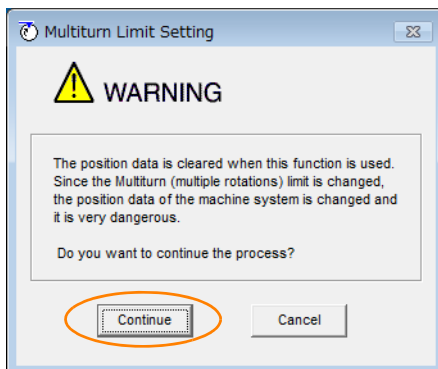

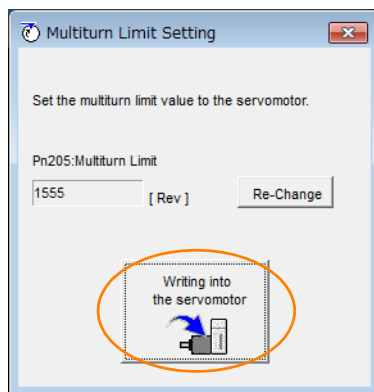

**10. Click the Writing into the servomotor Button.**

Click the **Re-change** Button to change the setting.

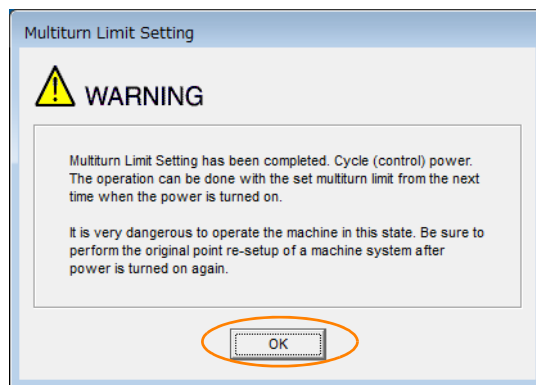
**11. Click the OK Button.**

This concludes the procedure to set the multiturn limit.

# 7.8 Absolute Linear Encoders

The absolute linear encoder records the current position of the stop position even when the power supply is OFF.

With a system that uses an absolute linear encoder, the host controller can monitor the current position. Therefore, it is not necessary to perform an origin return operation when the power supply to the system is turned ON.

There are two types of linear encoders for Linear Servomotors. The usage of the linear encoder is specified in Pn002 = n.□X□□.

Refer to the following section for linear encoder models.

 ■ Feedback Resolution of Linear Encoder on page 6-43

• Parameter Settings When Using an Incremental Linear Encoder

| Parameter |                             | Meaning   | When Enabled  | Classification |
|-----------|-----------------------------|---|---------------|----------------|
| Pn002     | n.□0□□<br>(default setting) | Use the encoder as an incremental linear encoder. | After restart | Setup          |
|           | n.□1□□                      | Use the encoder as an incremental linear encoder. |               |                |

• Parameter Settings When Using an Absolute Linear Encoder

| Parameter |                             | Meaning   | When Enabled  | Classification |
|-----------|-----------------------------|---|---------------|----------------|
| Pn002     | n.□0□□<br>(default setting) | Use the encoder as an absolute linear encoder.    | After restart | Setup          |
|           | n.□1□□                      | Use the encoder as an incremental linear encoder. |               |                |

## 7.8.1 Connecting an Absolute Linear Encoder

You can get the position data from the absolute linear encoder with EtherCAT communications.

Refer to the following section for information on connecting absolute linear encoders.

 4.4.3 Wiring the SERVOPACK to the Encoder on page 4-20

## 7.8.2 Structure of the Position Data of the Absolute Linear Encoder

The position data of the absolute linear encoder is the distance (number of pulses) from the origin of the absolute linear encoder.

The position data is signed 36-bit data.

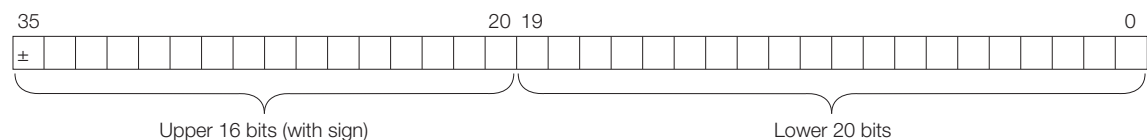

When the SERVOPACK sends the position data, it sends the upper 16-bit data (with sign) separately from the lower 20-bit data.

## 7.9 Software Reset

You can reset the SERVOPACK internally with the software. A software reset is used when resetting alarms and changing the settings of parameters that normally require turning the power supply to the SERVOPACK OFF and ON again. This can be used to change those parameters without turning the power supply to the SERVOPACK OFF and ON again.



The software reset applies to both axes A and B.  
If you reset the software, it will be reset for both axes.

### Information

1. Always confirm that the servo is OFF and that the Servomotor is stopped before you start a software reset.
2. This function resets the SERVOPACK independently of the host controller. The SERVOPACK carries out the same processing as when the power supply is turned ON and outputs the ALM (Servo Alarm) signal. The status of other output signals may be forcibly changed.
3. When you execute a software reset, the SERVOPACK will not respond for approximately five seconds.  
Before you execute a software reset, check the status of the SERVOPACK and Servomotor and make sure that no problems will occur.

### 7.9.1 Preparations

Always check the following before you perform a software reset.

- The servo must be OFF for both axis A and axis B.
- The motor must be stopped.

### 7.9.2 Applicable Tools

The following table lists the tools that you can use to perform a software reset.

| Tool             | Fn No./Function Name                    | Operating Procedure Reference  |
|------------------|---|--|
| Digital Operator | Fn030                                   | $\Sigma$ -7-Series Digital Operator Operating Manual (Manual No.: SIEP S800001 33) |
| SigmaWin+        | <b>Basic Functions - Software Reset</b> | 7.9.3 Operating Procedure on page 7-36   |

## 7.9.3 Operating Procedure

Use the following procedure to perform a software reset.

1. Click the  Servo Drive Button in the workspace of the Main Window of the SigmaWin+.
2. Select **Software Reset** in the Menu Dialog Box.  
The Software Reset Dialog Box will be displayed.
3. Click the **Execute** Button.

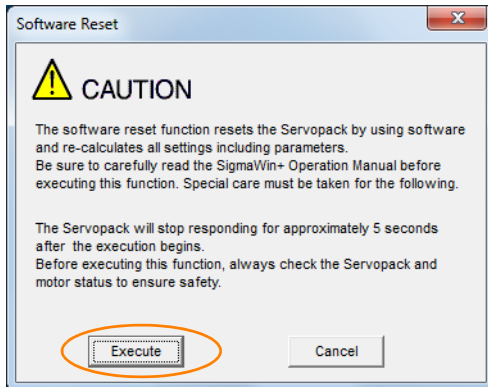

Click the **Cancel** Button to cancel the software reset. The Main Window will return.

4. Click the **Execute** Button.

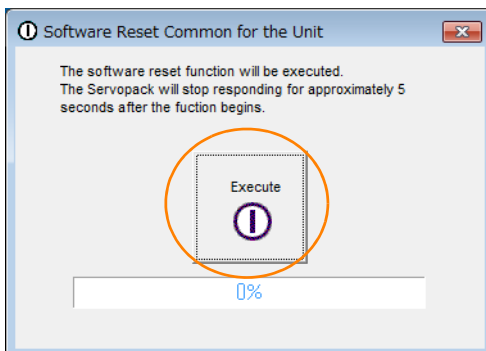

5. Click the **OK** Button to end the software reset operation.  
All settings including parameters will have been re-calculated. When you finish this operation, disconnect the SigmaWin+ from the SERVOPACK, and then connect it again.

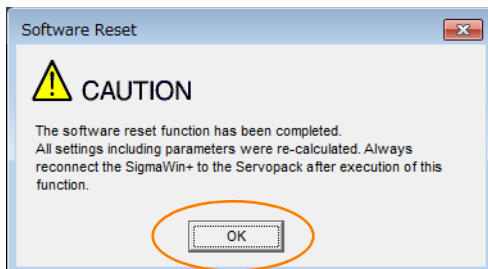

This concludes the procedure to reset the software.

## 7.10 Initializing the Vibration Detection Level

You can detect machine vibration during operation to automatically adjust the settings of Pn312 or Pn384 (Vibration Detection Level) to detect A.520 alarms (Vibration Alarm) and A.911 warnings (Vibration) more precisely.

This function detects specific vibration components in the Servomotor speed.

| Parameter        |                             | Meaning  | When Enabled | Classification |
|------------------|-----------------------------|--|--------------|----------------|
| Pn310<br>(2310h) | n.□□□0<br>(default setting) | Do not detect vibration.                           | Immediately  | Setup          |
|                  | n.□□□1                      | Output a warning (A.911) if vibration is detected. |              |                |
|                  | n.□□□2                      | Output an alarm (A.520) if vibration is detected.  |              |                |

If the vibration exceeds the detection level calculated with the following formula, an alarm or warning occurs according to Pn310 (Vibration Detection Selection).

- Rotary Servomotors

$$\text{Detection level} = \frac{\text{Vibration detection level (Pn312 [min-1])} \times \text{Vibration detection sensitivity (Pn311 [\%])}{100}$$

- Linear Servomotors

$$\text{Detection level} = \frac{\text{Vibration detection level (Pn384 [mm/s])} \times \text{Vibration detection sensitivity (Pn311 [\%])}{100}$$

Use this function only if A.520 or A.911 alarms are not output at the correct times when vibration is detected with the default vibration detection level (Pn312 or Pn384).

There will be discrepancies in the detection sensitivity for vibration alarms and warnings depending on the condition of your machine. If there is a discrepancy, use the above formula to adjust Pn311 (Vibration Detection Sensitivity).

| Pn311<br>(2311h) | Vibration Detection Sensitivity |              |                 |              | Speed          | Position | Torque |
|------------------|---------------------------------|--------------|-----------------|--------------|----------------|----------|--------|
|                  | Setting Range                   | Setting Unit | Default Setting | When Enabled | Classification |          |        |
|                  | 50 to 500                       | 1%           | 100             | Immediately  | Tuning         |          |        |

### Information

1. Vibration may not be detected because of unsuitable servo gains. Also, not all kinds of vibrations can be detected.
2. Set a suitable moment of inertia ratio (Pn103). An unsuitable setting may result in falsely detecting or not detecting vibration alarms or vibration warnings.
3. To use this function, you must input the actual references that will be used to operate your system.
4. Execute this function under the operating conditions for which you want to set the vibration detection level.
5. Execute this function while the motor is operating at 10% of its maximum speed or faster.



### 7.10.1 Preparations

Always check the following before you initialize the vibration detection level.

- The parameters must not be write prohibited.
- The test without a motor function must be disabled (Pn00C = n.□□□0).

## 7.10.2 Applicable Tools

The following table lists the tools that you can use to initialize the vibration detection level.

| Tool             | Fn No./Function Name                                 | Operating Procedure Reference  |
|------------------|--|--|
| Digital Operator | Fn01B  |  Σ-7-Series Digital Operator Operating Manual (Manual No.: SIEP S800001 33) |
| SigmaWin+        | <b>Others - Initialize Vibration Detection Level</b> |  7.10.3 Operating Procedure on page 7-38                                    |

## 7.10.3 Operating Procedure

Use the following procedure to initialize the vibration detection level.

1. Click the  Servo Drive Button in the workspace of the Main Window of the SigmaWin+.
2. Select **Initialize Vibration Detection Level** in the Menu Dialog Box.  
The Initialize Vibration Detection Level Dialog Box will be displayed.
3. Select **Pn311: Vibration Detection Sensitivity** and **Pn310: Vibration Detection Selections** and then click the **Detection Start** Button.  
A setting execution standby mode will be entered.

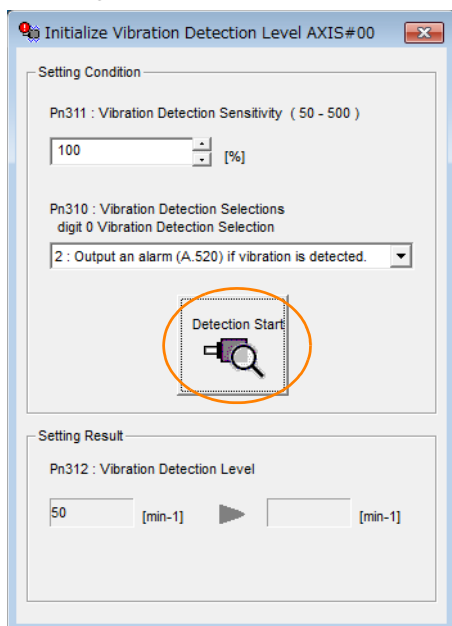

#### 4. Click the Execute Button.

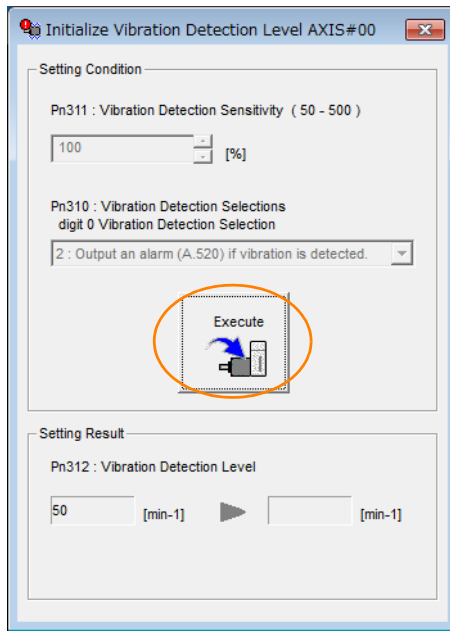

The newly set vibration detection level will be displayed and the value will be saved in the SERVO-PACK.

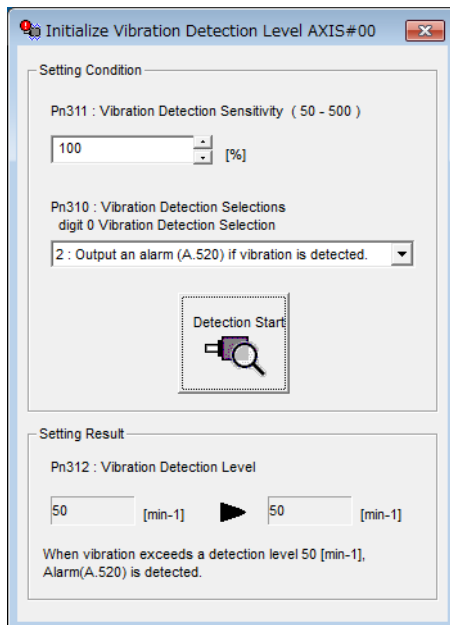

This concludes the procedure to initialize the vibration detection level.

## 7.10.4 Related Parameters

The following three items are given in the following table.

- Parameters Related to this Function  
These are the parameters that are used or referenced when this function is executed.
- Changes during Function Execution  
Not allowed: The parameter cannot be changed using the SigmaWin+ or other tool while this function is being executed.  
Allowed: The parameter can be changed using the SigmaWin+ or other tool while this function is being executed.
- Automatic Changes after Function Execution  
Yes: The parameter is automatically set or adjusted after execution of this function.  
No: The parameter is not automatically set or adjusted after execution of this function.

| Parameter     | Name                            | Setting Changes | Automatic Changes |
|---------------|---------------------------------|-----------------|-------------------|
| Pn311 (2311h) | Vibration Detection Sensitivity | Allowed         | No                |
| Pn312 (2312h) | Vibration Detection Level       | Not allowed     | Yes               |
| Pn384 (2384h) | Vibration Detection Level       | Not allowed     | Yes               |



## 7.11 Adjusting the Motor Current Detection Signal Offset

The motor current detection signal offset is used to reduce ripple in the torque. You can adjust the motor current detection signal offset either automatically or manually.

### 7.11.1 Automatic Adjustment

Perform this adjustment only if highly accurate adjustment is required to reduce torque ripple. You can specify the axis or axes to automatically adjust. It is normally not necessary to adjust this offset.



Important

Execute the automatic offset adjustment if the torque ripple is too large when compared with other SERVOPACKs.

#### Information

The offset does not use a parameter, so it will not change even if the parameter settings are initialized.

### Preparations

Always check the following before you automatically adjust the motor current detection signal offset.

- The parameters must not be write prohibited.
- The servo must be in ready status.
- The servo must be OFF.

### Applicable Tools

The following table lists the tools that you can use to automatically adjust the offset.

| Tool                    | Fn No./Function Name                                       | Operating Procedure Reference   |
|-------------------------|--|---|
| Digital Operator        | Fn00E  | $\Sigma$ -7-Series Digital Operator Operating Manual (Manual No. S1EP S800001 33) |
| SigmaWin+               | <b>Others – Adjust the Motor Current Detection Offsets</b> | Operating Procedure on page 7-41  |
| EtherCAT communications | SERVOPACK Adjusting Command (2710h)                        | SERVOPACK Adjusting Command (A: 2710h, B: 2F10h) on page 14-24                    |

### Operating Procedure

Use the following procedure to automatically adjust the motor current detection signal offset.

1. Click the Servo Drive Button in the workspace of the Main Window of the SigmaWin+.
2. Select **Adjust the Motor Current Detection Signal Offsets** in the Menu Dialog Box. The Adjust the Motor Current Detection Signal Offsets Dialog Box will be displayed.

3. Click the **Continue** Button.

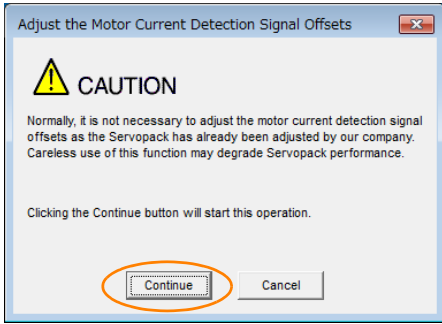

4. Click the **Automatic Adjustment** Tab in the Adjust the Motor Current Detection Signal Offsets Dialog Box.

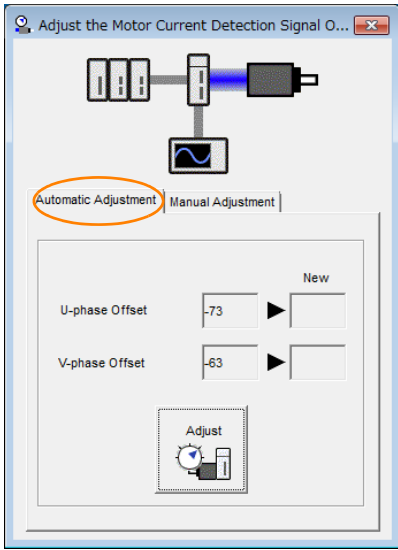

5. Click the **Adjust** Button.  
The values that result from automatic adjustment will be displayed in the **New** Boxes.

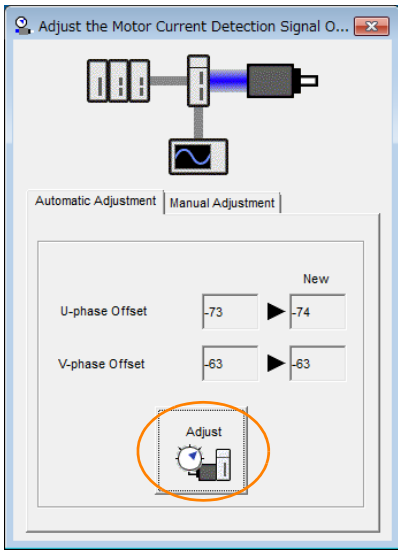

This concludes the procedure to automatically adjust the motor current detection signal offset.

## 7.11.2 Manual Adjustment

You can use this function if you automatically adjust the motor current detection signal offset and the torque ripple is still too large. You can specify the axis or axes to manually adjust.



Important

If the offset is incorrectly adjusted with this function, the Servomotor characteristics may be adversely affected.

Observe the following precautions when you manually adjust the offset.

- Operate the Servomotor at a speed of approximately 100 min<sup>-1</sup>.
- Adjust the offset while monitoring the torque reference with the analog monitor until the ripple is minimized.
- Adjust the offsets for the phase-U current and phase-V current of the Servomotor so that they are balanced. Alternately adjust both offsets several times.

Information

The offset does not use a parameter, so it will not change even if the parameter settings are initialized.

### Preparations

Always check the following before you manually adjust the motor current detection signal offset.

- The parameters must not be write prohibited.

### Applicable Tools

The following table lists the tools that you can use to manually adjust the offset.

| Tool             | Fn No./Function Name                                       | Operating Procedure Reference  |
|------------------|--|--|
| Digital Operator | Fn00F  | $\Sigma$ -7-Series Digital Operator Operating Manual (Manual No.: SIEP S800001 33) |
| SigmaWin+        | <i>Others – Adjust the Motor Current Detection Offsets</i> | Operating Procedure on page 7-43   |

### Operating Procedure

Use the following procedure to manually adjust the motor current detection signal offset.

1. Operate the motor at approximately 100 min<sup>-1</sup>.
2. Click the Servo Drive Button in the workspace of the Main Window of the SigmaWin+.
3. Select **Adjust the Motor Current Detection Signal Offsets** in the Menu Dialog Box. The Adjust the Motor Current Detection Signal Offsets Dialog Box will be displayed.
4. Click the **Continue** Button.

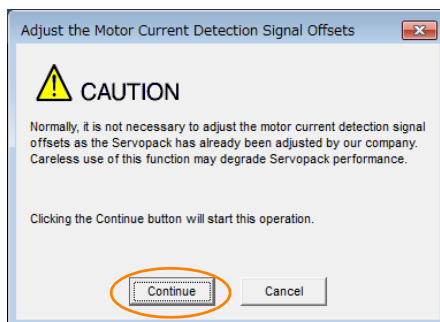

5. Click the **Manual Adjustment** Tab in the Adjust the Motor Current Detection Signal Offsets Dialog Box.

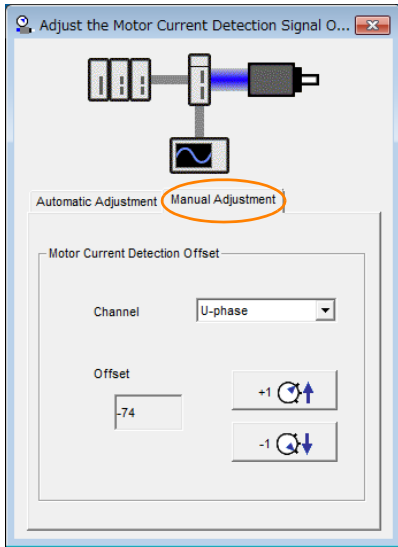

6. Set the **Channel** Box in the **Motor Current Detection Offset** Area to **U-phase**.
7. Use the **+1** and **-1** Buttons to adjust the offset for phase **U**.  
Change the offset by about 10 in the direction that reduces the torque ripple.  
Adjustment range: -512 to +511
8. Set the **Channel** Box in the **Motor Current Detection Offset** Area to **V-phase**.
9. Use the **+1** and **-1** Buttons to adjust the offset for phase **V**.  
Change the offset by about 10 in the direction that reduces the torque ripple.
10. Repeat steps 6 to 9 until the torque ripple cannot be improved any further regardless of whether you increase or decrease the offsets.
11. Reduce the amount by which you change the offsets each time and repeat steps 6 to 9.

This concludes the procedure to manually adjust the motor current detection signal offset.

## 7.12 Forcing the Motor to Stop

You can force the Servomotor to stop for a signal from the host controller or an external device.

To force the motor to stop, you must allocate the FSTP (Forced Stop Input) signal in Pn516 = n.□□□X. You can specify one of the following stopping methods: dynamic brake (DB), coasting to a stop, or decelerating to a stop.

Note: Forcing the motor to stop is not designed to comply with any safety standard. In this respect, it is different from the hard wire base block (HWBB).

**Information** Digital Operator Displays  
When a forced stop is performed, the Digital Operator will display FSTP.

### CAUTION

- To prevent accidents that may result from contact faults or disconnections, use a normally closed switch for the Forced Stop Input signal.

### 7.12.1 FSTP (Forced Stop Input) Signal

| Classification | Signal | Connector Pin No.  | Signal Status | Description                          |
|----------------|--------|--------------------|---------------|--------------------------------------|
| Input          | FSTP   | Must be allocated. | ON (closed)   | Drive is enabled (normal operation). |
|                |        |                    | OFF (open)    | The motor is stopped.                |

Note: You must allocate the FSTP signal to use it. The parameters that you use depend on the allocation method.

| Allocation Method                      | Parameters to Use  |
|--|--|
| Σ-7S-compatible I/O signal allocations | <ul style="list-style-type: none"> <li>• Pn50A = n.□□□1 (Σ-7S-Compatible I/O Signal Allocations)</li> <li>• Pn516 = n.□□□X (FSTP (Forced Stop Input) Signal Allocation)</li> </ul> |
| Multi-axis I/O signal allocations      | <ul style="list-style-type: none"> <li>• Pn50A = n.□□□2 (Multi-Axis I/O Signal Allocations)</li> <li>• Pn597 (FSTP (Forced Stop Input) Signal Allocation)</li> </ul>               |

Refer to the following section for details.

 7.1.1 Input Signal Allocations on page 7-4

### 7.12.2 Stopping Method Selection for Forced Stops

Use Pn00A = n.□□X□ (Stopping Method for Forced Stops) to set the stopping method for forced stops.

| Parameter        | Description                 | When Enabled  | Classification |
|------------------|-----------------------------|---------------|----------------|
| Pn00A<br>(200Ah) | n.□□0□                      | After restart | Setup          |
|                  | n.□□1□<br>(default setting) |               |                |
|                  | n.□□2□                      |               |                |
|                  | n.□□3□                      |               |                |
|                  | n.□□4□                      |               |                |

Note: You cannot decelerate a Servomotor to a stop during torque control. For torque control, the Servomotor will be stopped with the dynamic braking or coast to a stop according to the setting of Pn001 = n.□□□X (Motor Stopping Method for Servo OFF and Group 1 Alarms).

## Stopping the Servomotor by Setting Emergency Stop Torque (Pn406)

To stop the Servomotor by setting emergency stop torque, set Pn406 (Emergency Stop Torque).

If Pn00A = n.□□X□ is set to 1 or 2, the Servomotor will be decelerated to a stop using the torque set in Pn406 as the maximum torque.

The default setting is 800%. This setting is large enough to allow you to operate the Servomotor at the maximum torque. However, the maximum emergency stop torque that you can actually use is the maximum torque of the Servomotor.

| Pn406<br>(2406h) | Emergency Stop Torque |              |                 | Speed        | Position       |
|------------------|-----------------------|--------------|-----------------|--------------|----------------|
|                  | Setting Range         | Setting Unit | Default Setting | When Enabled | Classification |
|                  | 0 to 800              | 1%*          | 800             | Immediately  | Setup          |

\* Set a percentage of the motor rated torque.

## Stopping the Servomotor by Setting the Deceleration Time for Servo OFF and Forced Stops (Pn30A)

To specify the Servomotor deceleration time and use it to stop the Servomotor, set Pn30A (Deceleration Time for Servo OFF and Forced Stops).

| Pn30A<br>(230Ah) | Deceleration Time for Servo OFF and Forced Stops |              |                 | Speed        | Position       |
|------------------|--|--------------|-----------------|--------------|----------------|
|                  | Setting Range                                    | Setting Unit | Default Setting | When Enabled | Classification |
|                  | 0 to 10,000                                      | 1 ms         | 0               | Immediately  | Setup          |

If you set Pn30A to 0, the Servomotor will be stopped with a zero speed.

The deceleration time that you set in Pn30A is the time to decelerate the motor from the maximum motor speed.

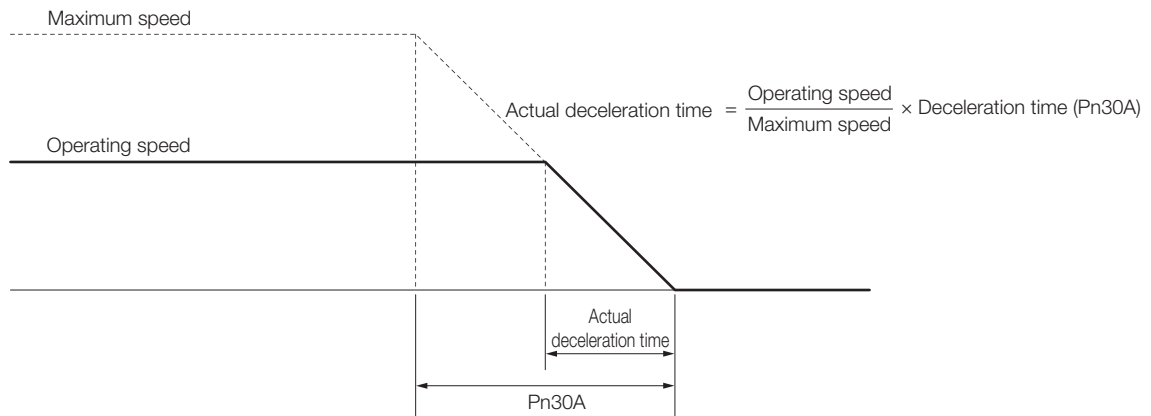

## 7.12.3 Resetting Method for Forced Stops

This section describes the reset methods that can be used after stopping operation for an FSTP (Forced Stop Input) signal.

If the FSTP (Forced Stop Input) signal is OFF and the Servo ON command (Enable Operation command) is input, the forced stop state will be maintained even after the FSTP signal is turned ON.

Send the Servo OFF command (Disable Operation command) to place the SERVOPACK in the base block (BB) state and then send the Servo ON command (Enable Operation command).

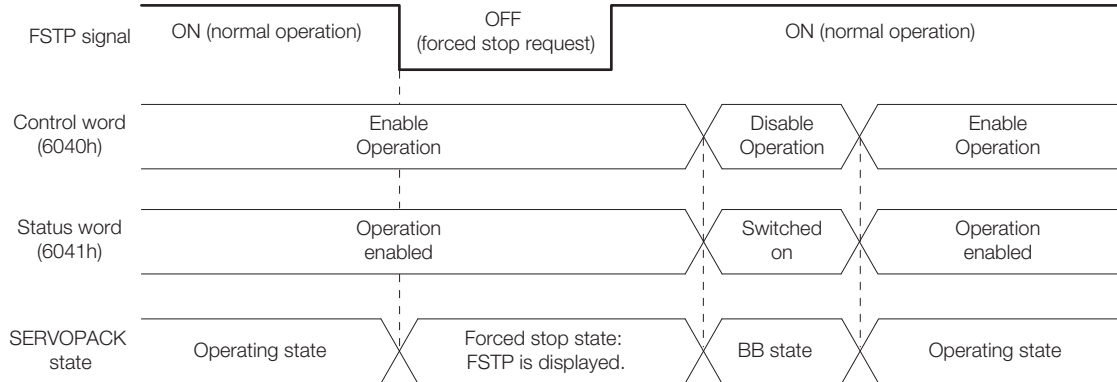

## 7.13 Overheat Protection

Overheat protection detects an A.93B warning (Overheat Warning) and an A.862 alarm (Overheat Alarm) by monitoring the overheat protection input signal (TH) from a Yaskawa SGLFW2 Linear Servomotor or from a sensor attached to the machine.

SERVOPACKs with software version 0024 or higher support overheat protection.

When you use overheat protection, you must wire the overheat protection input (TH) signal and select overheat protection (Pn61A = n.□□□X).

### 7.13.1 Connecting the Overheat Protection Input (TH) Signal

To use overheat protection, you must connect an overheat protection input (TH) signal to the SERVOPACK. This section describes the connection methods for the overheat protection input (TH) signal.

#### Using Overheat Protection in the Linear Servomotor

##### ◆ When Using a Serial Converter Unit

Connect the connector for the polarity sensor (hall sensor) and thermal protector of the linear servomotor to the serial converter unit.

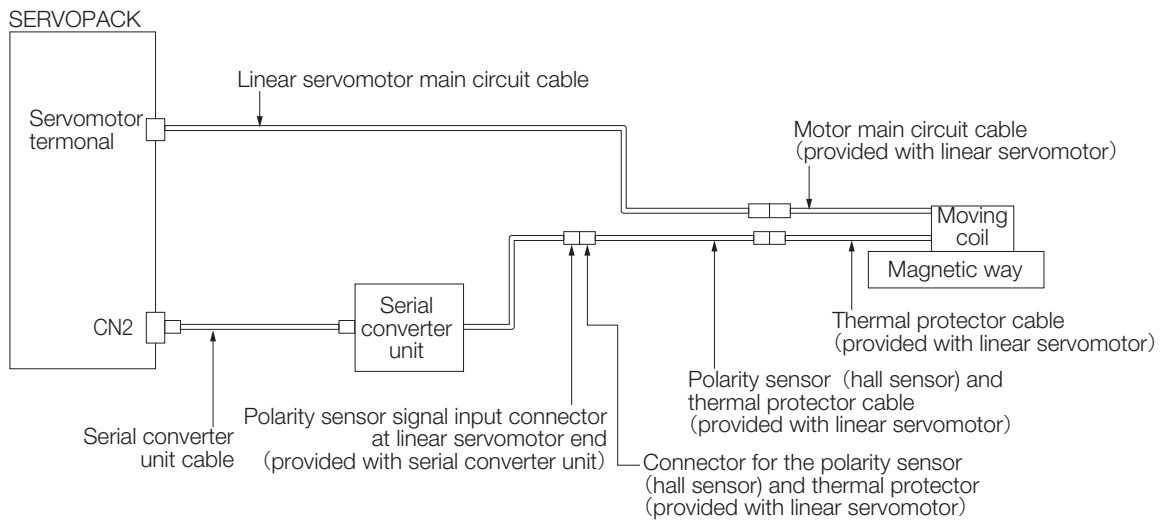



## Using Overheat Protection for the Machine

To use overheat protection for the machine, connect the overheat protection input (an analog voltage input) from the sensor mounted to the machine to the CN1-5 or CN1-17 on the SERVOPACK.

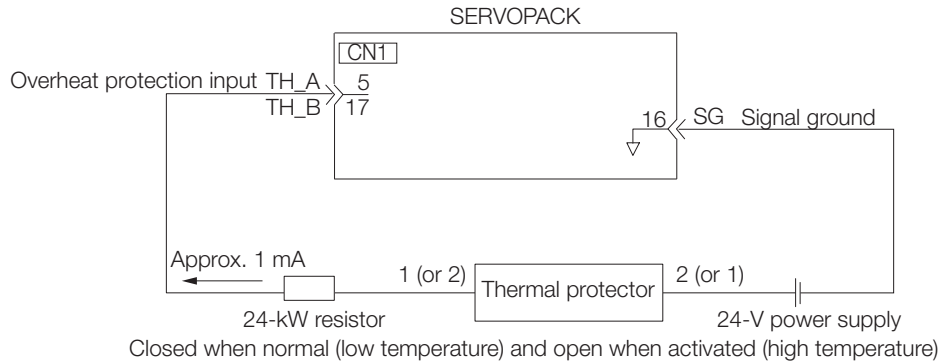

Important

- The recommended length of the thermal protector cable is 15 m maximum.
- The 24-V power supply and 24-k $\Omega$  resistor are not provided by Yaskawa. Use a 0.3 W or greater 24-V power supply, and use a 0.2 W or greater 24-k $\Omega$  resistor.
- Be sure to connect the positive and negative sides of the power supply correctly. Otherwise there is a risk of SERVOPACK failure.

## 7.13.2 Overheat Protection Selections

The overheat protection function is selected with Pn61A = n.□□□X (Overheat Protection Selections).

| Parameter        |                             | Meaning   | When Enabled  | Classification |
|------------------|-----------------------------|---|---------------|----------------|
| Pn61A<br>(261Ah) | n.□□□0<br>(default setting) | Disable overheat protection.  | After restart | Setup          |
|                  | n.□□□1                      | Use overheat protection in the Yaskawa Linear Servomotor.*  |               |                |
|                  | n.□□□2                      | Monitor a negative voltage input from a sensor attached to the machine and use overheat protection. |               |                |
|                  | n.□□□3                      | Monitor a positive voltage input from a sensor attached to the machine and use overheat protection. |               |                |

\* The SGLFW2 is the only Yaskawa Linear Servomotor that supports this function.

## Using Overheat Protection in the Yaskawa Linear Servomotor

To use the overheat protection in a Yaskawa Linear Servomotor (SGLFW2), set Pn61A to n.□□□1.

An A.93B warning (Overheat Warning) will be detected if the overheat protection input (TH) signal from the Yaskawa SGLFW2 Linear Servomotor exceeds the warning temperature.

An A.862 alarm (Overheat Alarm) will be detected if the overheat protection input (TH) signal from the Yaskawa SGLFW2 Linear Servomotor exceeds the alarm temperature.



Important

- If the overheat protection input signal line is disconnected or short-circuited, an A.862 alarm will occur.
- If you set Pn61A to n.□□□1 (Use overheat protection in the Yaskawa Linear Servomotor), the parameters in the Servomotor are enabled and the following parameters are disabled.
  - Overheat Alarm Level (Pn61B)
  - Overheat Warning Level (Pn61C)
  - Overheat Alarm Filter Time (Pn61D)

## Monitoring the Machine's Temperature and Using Overheat Protection

Set Pn61A = n.□□□X to 2 or 3 to use overheat protection for the machine.

Set the following parameters as required.

|                  |   |              |                 |              |                |
|------------------|---|--------------|-----------------|--------------|----------------|
| Pn61B<br>(261Bh) | Overheat Alarm Level <span style="float: right;">[Speed] [Position] [Torque]</span>       |              |                 |              |                |
|                  | Setting Range   | Setting Unit | Default Setting | When Enabled | Classification |
| Common           | 0 to 500  | 0.01 V       | 250             | Immediately  | Setup          |
| Pn61C<br>(261Ch) | Overheat Warning Level <span style="float: right;">[Speed] [Position] [Torque]</span>     |              |                 |              |                |
|                  | Setting Range   | Setting Unit | Default Setting | When Enabled | Classification |
| Common           | 0 to 100  | 1%           | 100             | Immediately  | Setup          |
| Pn61D<br>(261Dh) | Overheat Alarm Filter Time <span style="float: right;">[Speed] [Position] [Torque]</span> |              |                 |              |                |
|                  | Setting Range   | Setting Unit | Default Setting | When Enabled | Classification |
| Common           | 0 to 65,535   | 1 s          | 0               | Immediately  | Setup          |



Important

- When Pn61A is set to n.□□□2, an A.862 alarm will occur if the overheat protection input signal line is disconnected or short-circuited.
- When Pn61A is set to n.□□□3, an A.862 alarm will not occur if the overheat protection input signal line is disconnected or short-circuited. To ensure safety, we recommend that you connect the external circuits so that you can use a negative voltage input for the overheat protection input (an analog voltage input).

# Trial Operation and Actual Operation

# 8

This chapter provides information on the flow and procedures for trial operation and convenient functions to use during trial operation.





|            |   |             |
|------------|---|-------------|
| <b>8.1</b> | <b>Flow of Trial Operation</b> . . . . .                                | <b>8-2</b>  |
| 8.1.1      | Flow of Trial Operation for Rotary Servomotors . .                      | 8-2         |
| 8.1.2      | Flow of Trial Operation for Linear Servomotors . .                      | 8-4         |
| <b>8.2</b> | <b>Inspections and Confirmations before Trial Operation</b> . .         | <b>8-6</b>  |
| <b>8.3</b> | <b>Trial Operation for the Servomotor without a Load</b> . .            | <b>8-7</b>  |
| 8.3.1      | Preparations . . . . .  | 8-7         |
| 8.3.2      | Applicable Tools . . . . .  | 8-8         |
| 8.3.3      | Operating Procedure . . . . .   | 8-8         |
| <b>8.4</b> | <b>Trial Operation with EtherCAT (CoE) Communications</b> . .           | <b>8-10</b> |
| <b>8.5</b> | <b>Trial Operation with the Servomotor Connected to the Machine</b> . . | <b>8-11</b> |
| 8.5.1      | Precautions . . . . .   | 8-11        |
| 8.5.2      | Preparations . . . . .  | 8-11        |
| 8.5.3      | Operating Procedure . . . . .   | 8-12        |
| <b>8.6</b> | <b>Convenient Function to Use during Trial Operation</b> . .            | <b>8-13</b> |
| 8.6.1      | Program Jogging . . . . .   | 8-13        |
| 8.6.2      | Origin Search . . . . .   | 8-19        |
| 8.6.3      | Test without a Motor . . . . .  | 8-21        |

## 8.1 Flow of Trial Operation





### 8.1.1 Flow of Trial Operation for Rotary Servomotors

The procedure for trial operation is given below.

- Preparations for Trial Operation

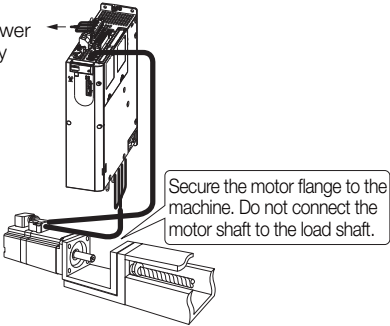
| Step | Meaning   | Reference   |
|------|---|---|
| 1    | <b>Installation</b><br>Install the Servomotor and SERVOPACK according to the installation conditions. First, operation is checked with no load. Do not connect the Servomotor to the machine. |  <i>Chapter 3 SERVOPACK Installation</i>                                     |
| 2    | <b>Wiring and Connections</b><br>Wire and connect the SERVOPACK. First, Servomotor operation is checked without a load. Do not connect the CN1 connector on the SERVOPACK.                    |  <i>Chapter 4 Wiring and Connecting SERVOPACKs</i>                           |
| 3    | <b>Confirmations before Trial Operation</b>   |  <i>8.2 Inspections and Confirmations before Trial Operation on page 8-6</i> |
| 4    | <b>Power ON</b>   | –   |
| 5    | <b>Resetting the Absolute Encoder</b><br>This step is necessary only for a Servomotor with an absolute encoder.   |  <i>6.15 Resetting the Absolute Encoder on page 6-48</i>                     |

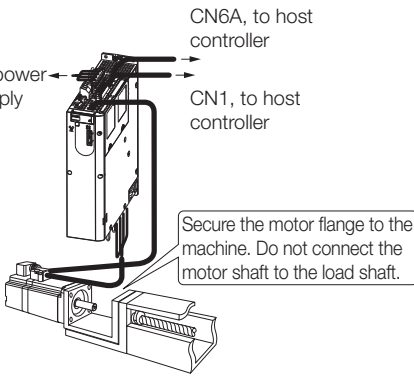
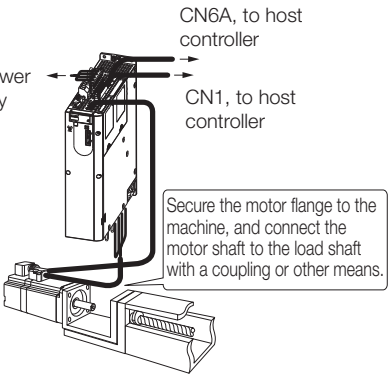



• Trial Operation

| Step | Meaning   | Reference  |
|------|---|--|
| 1    | <p>Trial Operation for the Servomotor without a Load</p>               | <p> 8.3 Trial Operation for the Servomotor without a Load on page 8-7</p>               |
| 2    | <p>Trial Operation with EtherCAT (CoE) Communications</p>             | <p> 8.4 Trial Operation with EtherCAT (CoE) Communications on page 8-10</p>             |
| 3    | <p>Trial Operation with the Servomotor Connected to the Machine</p>  | <p> 8.5 Trial Operation with the Servomotor Connected to the Machine on page 8-11</p> |







## 8.1.2 Flow of Trial Operation for Linear Servomotors

The procedure for trial operation is given below.

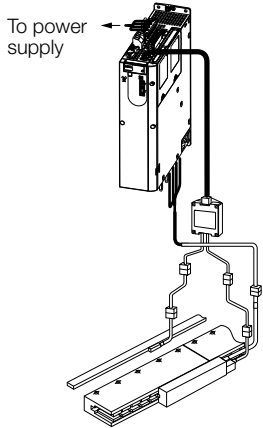
- Preparations for Trial Operation

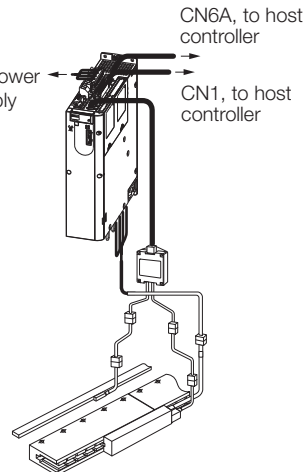
| Step | Meaning   | Reference   |   |  |           |
|------|---|---|---|--|-----------|
| 1    | <b>Installation</b><br>Install the Servomotor and SERVOPACK according to the installation conditions. First, operation is checked with no load. Do not connect the Servomotor to the machine. |  Chapter 3 SERVOPACK Installation  |   |  |           |
| 2    | <b>Wiring and Connections</b><br>Wire and connect the SERVOPACK. First, Servomotor operation is checked without a load. Do not connect the CN1 connector on the SERVOPACK.                    |  Chapter 4 Wiring and Connecting SERVOPACKs                              |   |  |           |
| 3    | <b>Confirmations before Trial Operation</b>   |  8.2 Inspections and Confirmations before Trial Operation on page 8-6    |   |  |           |
| 4    | <b>Power ON</b>   | –   |   |  |           |
| 5    | <b>Setting Parameters in the SERVOPACK</b>  |   |   |  |           |
|      | Step  | No. of Parameter to Set   | Description                                 | Remarks  | Reference |
|      | 5-1   | Pn282 (2282h)   | Linear Encoder Pitch                        | Set this parameter only if you are using a Serial Converter Unit.              | page 6-14 |
|      | 5-2   | –   | Writing Parameters to the Linear Servomotor | Set this parameter only if you are not using a Serial Converter Unit.          | page 6-15 |
|      | 5-3   | Pn080 (2080h) = n.□□X□  | Motor Phase Sequence Selection              | –  | page 6-19 |
|      | 5-4   | Pn080 (2080h) = n.□□□X  | Polarity Sensor Selection                   | –  | page 6-21 |
|      | 5-5   | –   | Polarity Detection                          | This step is necessary only for a Linear Servomotor without a Polarity Sensor. | page 6-22 |
|      | 5-6   | Pn50A (250Ah) = n.X□□□ and Pn50B (250Bh) = n.□□□X<br>Or<br>Pn590 (2590h) and Pn591 (2591h)  | Overtravel Signal Allocations               | –  | page 6-25 |
|      | 5-7   | Pn483 (2483h), Pn484 (2484h)  | Force Control                               | –  | page 7-23 |
| 6    | <b>Setting the Origin of the Absolute Linear Encoder</b>  |  6.16.2 Setting the Origin of the Absolute Linear Encoder on page 6-51 |   |  |           |

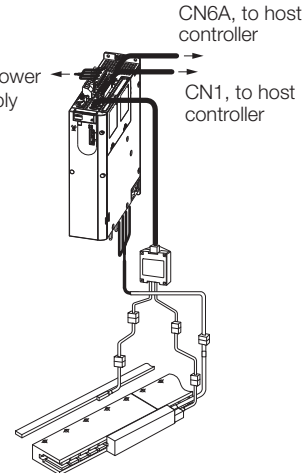
• Trial Operation

| Step | Meaning   | Reference  |
|------|---|--|
| 1    | <p>Trial Operation for the Servomotor without a Load</p>               | <p> 8.3 Trial Operation for the Servomotor without a Load on page 8-7</p>               |
| 2    | <p>Trial Operation with EtherCAT (CoE) Communications</p>             | <p> 8.4 Trial Operation with EtherCAT (CoE) Communications on page 8-10</p>           |
| 3    | <p>Trial Operation with the Servomotor Connected to the Machine</p>  | <p> 8.5 Trial Operation with the Servomotor Connected to the Machine on page 8-11</p> |

## 8.2 Inspections and Confirmations before Trial Operation

To ensure safe and correct trial operation, check the following items before you start trial operation.

- Make sure that the SERVOPACK and Servomotor are installed, wired, and connected correctly.
- Make sure that the correct power supply voltage is supplied to the SERVOPACK.
- Make sure that there are no loose parts in the Servomotor mounting.
- If you are using a Servomotor with an Oil Seal, make sure that the oil seal is not damaged. Also make sure that oil has been applied.
- If you are performing trial operation on a Servomotor that has been stored for a long period of time, make sure that all Servomotor inspection and maintenance procedures have been completed.

Refer to the manual for your Servomotor for Servomotor maintenance and inspection information.

- If you are using a Servomotor with a Holding Brake, make sure that the brake is released in advance. To release the brake, you must apply the specified voltage of 24 VDC to the brake. A circuit example for trial operation is provided below.

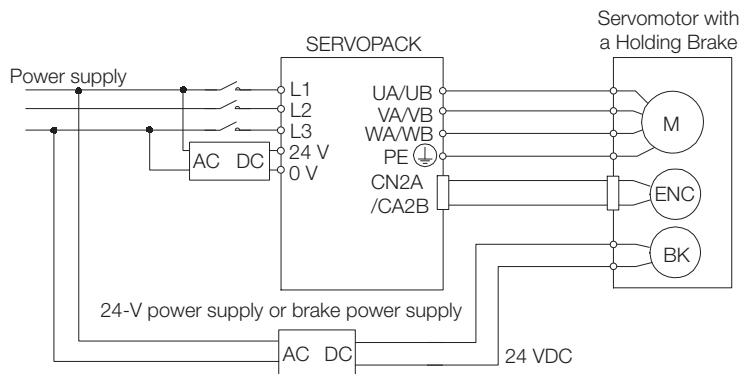



## 8.3

## Trial Operation for the Servomotor without a Load

You use jogging for trial operation of the Servomotor without a load.

Jogging is used to check the operation of the Servomotor without connecting the SERVOPACK to the host controller. The Servomotor is moved at the preset jogging speed.

 **CAUTION**

- During jogging, the overtravel function is disabled. Consider the range of motion of your machine when you jog the Servomotor.



The tuning-less function is enabled as the default setting. If the tuning-less function is enabled, gain may increase and vibrations may occur with no load. If vibrations occur, disable the tuning-less function (Pn170=n.□□□0).

## 8.3.1 Preparations

Confirm the following conditions before you jog the Servomotor.

- The parameters must not be write prohibited.
- The main circuit power supply must be ON.
- There must be no alarms.
- There must be no hard wire base block (HWBB).
- The servo must be OFF.
- The jogging speed must be set considering the operating range of the machine.  
The jogging speed is set with the following parameters.

- Rotary Servomotors

|                  |  |                     |                 |              |                |
|------------------|--|---------------------|-----------------|--------------|----------------|
| Pn304<br>(2304h) | Jogging Speed <span style="float:right">[Speed] [Position] [Torque]</span> |                     |                 |              |                |
|                  | Setting Range  | Setting Unit        | Default Setting | When Enabled | Classification |
|                  | 0 to 10,000  | 1 min <sup>-1</sup> | 500             | Immediately  | Setup          |
| Pn305<br>(2305h) | Soft Start Acceleration Time <span style="float:right">[Speed]</span>      |                     |                 |              |                |
|                  | Setting Range  | Setting Unit        | Default Setting | When Enabled | Classification |
|                  | 0 to 10,000  | 1 ms                | 0               | Immediately  | Setup          |
| Pn306<br>(2306h) | Soft Start Deceleration Time <span style="float:right">[Speed]</span>      |                     |                 |              |                |
|                  | Setting Range  | Setting Unit        | Default Setting | When Enabled | Classification |
|                  | 0 to 10,000  | 1 ms                | 0               | Immediately  | Setup          |

- Linear Servomotors

|                  |   |              |                 |              |                |
|------------------|---|--------------|-----------------|--------------|----------------|
| Pn383<br>(2383h) | Jogging Speed <span style="float:right">[Speed] [Position] [Force]</span> |              |                 |              |                |
|                  | Setting Range   | Setting Unit | Default Setting | When Enabled | Classification |
|                  | 0 to 10,000   | 1 mm/s       | 50              | Immediately  | Setup          |
| Pn305<br>(2305h) | Soft Start Acceleration Time <span style="float:right">[Speed]</span>     |              |                 |              |                |
|                  | Setting Range   | Setting Unit | Default Setting | When Enabled | Classification |
|                  | 0 to 10,000   | 1 ms         | 0               | Immediately  | Setup          |
| Pn306<br>(2306h) | Soft Start Deceleration Time <span style="float:right">[Speed]</span>     |              |                 |              |                |
|                  | Setting Range   | Setting Unit | Default Setting | When Enabled | Classification |
|                  | 0 to 10,000   | 1 ms         | 0               | Immediately  | Setup          |

## 8.3.2 Applicable Tools

The following table lists the tools that you can use to perform jogging.

| Tool             | Fn No./Function Name   | Operating Procedure Reference  |
|------------------|------------------------|--|
| Digital Operator | Fn002                  | Σ-7-Series Digital Operator Operating Manual (Manual No.: SIEP S800001 33) |
| SigmaWin+        | <b>Operation - Jog</b> | Operating Procedure on page 8-8  |

## 8.3.3 Operating Procedure

Use the following procedure to jog the motor.

1. Click the Servo Drive Button in the workspace of the Main Window of the SigmaWin+.
2. Select **JOG Operation** in the Menu Dialog Box.  
The Jog Operation Dialog Box will be displayed.
3. Read the warnings and then click the **OK** Button.

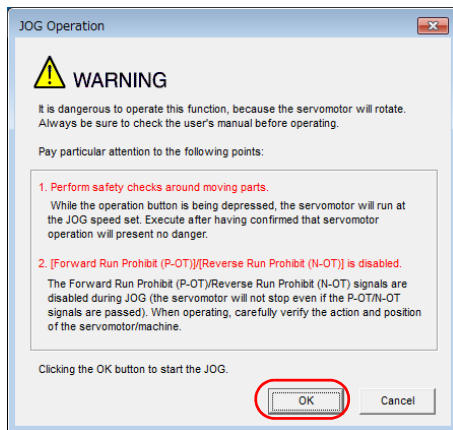

4. Check the jogging speed and then click the **Servo ON** Button.

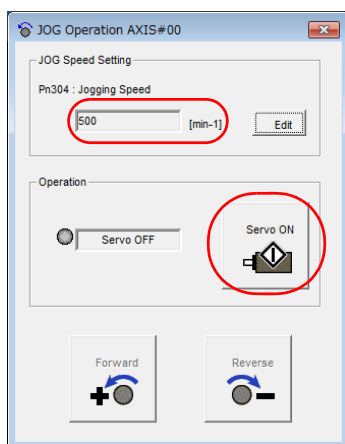

The display in the **Operation** Area will change to **Servo ON**.

**Information** To change the speed, click the **Edit** Button and enter the new speed.

**5. Click the Forward Button or the Reverse Button.**

Jogging will be performed only while you hold down the mouse button.

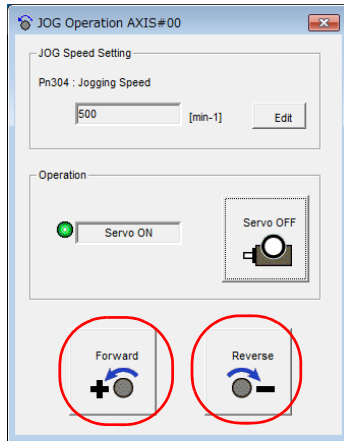
**6. After you finish jogging, turn the power supply to the SERVOPACK OFF and ON again.**

This concludes the jogging procedure.

# 8.4 Trial Operation with EtherCAT (CoE) Communications

A trial operation example for EtherCAT (CoE) communications is given below.

In this example, operation in Profile Position Mode is described.

Refer to the following chapter for details on operation with EtherCAT (CoE) communications.

 Chapter 13 CiA402 Drive Profile

1. Confirm that the wiring is correct, and then connect the I/O signal connector (CN1) and EtherCAT communications connector (CN6A).

Refer to the following chapter for details on wiring.

 Chapter 4 Wiring and Connecting SERVOPACKs

2. Set the EtherCAT (CoE) communications station address and PDO mappings.

3. Turn ON the power supplies to the SERVOPACK.

If power is being supplied correctly, the CHARGE indicator on the SERVOPACK will light.

Note: If the COM indicator does not light, recheck the settings of EtherCAT setting switches (S1 and S2) and then turn the power supply OFF and ON again.

4. Place the EtherCAT communications in the Operational state.

Refer to the following chapter for details on the EtherCAT communications status.

 12.2 EtherCAT State Machine on page 12-3

5. Set the modes of operation to Profile Position Mode.

Refer to the following section for details on modes of operation.

 Modes of Operation (A: 6060h, B: 6860h) on page 14-34

6. Change the *control word* to supply power to the motor.



When *status word* shows the Operation Enabled state, power is supplied to the motor.

Note: Manipulate the objects that were mapped to PDOs.  
Values will not be written if you manipulate SDOs.

7. Set *target position*, *profile velocity*, *profile acceleration*, and *profile deceleration*, and then manipulate *control word* to start positioning.

Note: Manipulate the objects that were mapped to PDOs.  
Values will not be written if you manipulate SDOs.

8. While operation is in progress for step 6, confirm the following items.

| Confirmation Item   | Reference  |
|---|--|
| Confirm that the rotational direction of the Servomotor agrees with the forward or reverse reference. If they do not agree, correct the rotation direction of the Servomotor. |  6.4 Motor Direction Setting on page 6-13   |
| Confirm that no abnormal vibration, noise, or temperature rise occurs. If any abnormalities are found, implement corrections.   |  15.4 Troubleshooting Based on the Operation and Conditions of the Servomotor on page 15-53 |

Note: If the load machine is not sufficiently broken in before trial operation, the Servomotor may become overloaded.

## 8.5

## Trial Operation with the Servomotor Connected to the Machine

This section provides the procedure for trial operation with both the machine and Servomotor.

## 8.5.1

## Precautions

**WARNING**

- Operating mistakes that occur after the Servomotor is connected to the machine may not only damage the machine, but they may also cause accidents resulting in personal injury.



Important

If you disabled the overtravel function for trial operation of the Servomotor without a load, enable the overtravel function (P-OT and N-OT signal) before you perform trial operation with the Servomotor connected to the machine in order to provide protection.

If you will use a holding brake, observe the following precautions during trial operation.

- Before you check the operation of the brake, implement measures to prevent the machine from falling due to gravity and to prevent vibration from being caused by an external force.
- First check the Servomotor operation and brake operation with the Servomotor uncoupled from the machine. If no problems are found, connect the Servomotor to the machine and perform trial operation again.

Control the operation of the brake with the /BK (Brake) signal output from the SERVOPACK.

Refer to the following sections for information on wiring and the related parameter settings.

 4.4.4 *Wiring the SERVOPACK to the Holding Brake* on page 4-33

 6.11 *Holding Brake* on page 6-31



Important

Failures caused by incorrect wiring or incorrect voltage application in the brake circuit may cause the SERVOPACK to fail, damage the SERVOPACK, damage the equipment, or cause an accident resulting in death or injury.

Observe the precautions and instructions for wiring and trial operation precisely as described in this manual.





## 8.5.2

## Preparations

Confirm the following items before you perform the trial operation procedure for both the machine and Servomotor.

- Make sure that the procedure described in 8.4 *Trial Operation with EtherCAT (CoE) Communications* on page 8-10 has been completed.
- Make sure that the SERVOPACK is connected correctly to both the host controller and the peripheral devices.
  - Overtravel wiring
  - Brake wiring
  - Allocation of the /BK (Brake) signal to a pin on the I/O signal connector (CN1)
  - Emergency stop circuit wiring
  - Host controller wiring

## 8.5.3 Operating Procedure

1. Enable the overtravel signals.  
 6.10.2 Setting to Enable/Disable Overtravel on page 6-26
2. Make the settings for the protective functions, such as the safety function, overtravel, and the brake.  
 4.6 Connecting Safety Function Signals on page 4-43  
 6.10 Overtravel and Related Settings on page 6-25  
 6.11 Holding Brake on page 6-31

3. Turn OFF the power supplies to the SERVOPACK.  
 The control power supply and main circuit power supply will turn OFF.

4. Couple the Servomotor to the machine.

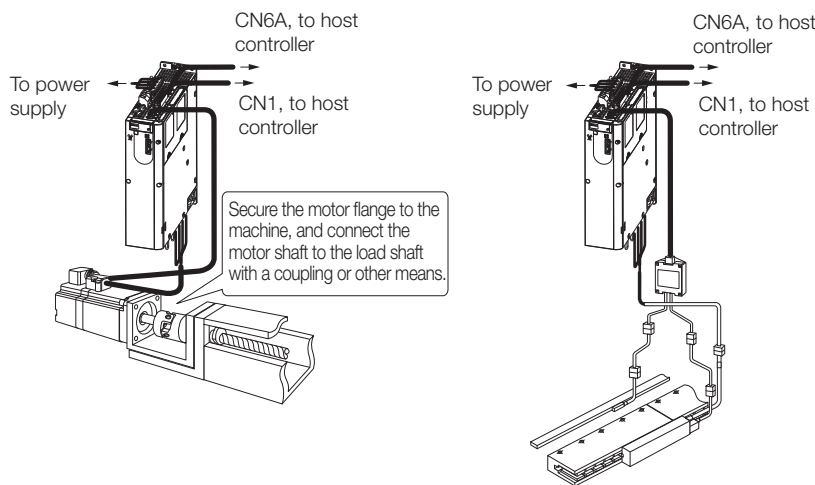

5. Turn ON the power supplies to the machine and host controller and turn ON the control power supply and main circuit power supply to the SERVOPACK.
6. Check the protective functions, such as overtravel and the brake, to confirm that they operate correctly.  
 Note: Enable activating an emergency stop so that the Servomotor can be stopped safely should an error occur during the remainder of the procedure.
7. Input the Enable Operation command from the host controller.  
 The servo will turn ON.
8. Perform trial operation according to 8.4 Trial Operation with EtherCAT (CoE) Communications on page 8-10 and confirm that the same results are obtained as when trial operation was performed on the Servomotor without a load.
9. If necessary, adjust the servo gain to improve the Servomotor response characteristics.  
 The Servomotor and machine may not be broken in completely for the trial operation. Therefore, let the system run for a sufficient amount of time to ensure that it is properly broken in.
10. For future maintenance, save the parameter settings with one of the following methods.
  - Use the SigmaWin+ to save the parameters as a file.
  - Use the Parameter Copy Mode of the Digital Operator.
  - Record the settings manually.

This concludes the procedure for trial operation with both the machine and Servomotor.

**8.6****Convenient Function to Use during Trial Operation**

This section describes some convenient operations that you can use during trial operation. Use them as required.

**8.6.1 Program Jogging**

You can use program jogging to perform continuous operation with a preset operation pattern, travel distance, movement speed, acceleration/deceleration time, waiting time, and number of movements.

You can use this operation when you set up the system in the same way as for normal jogging to move the Servomotor without connecting it to the host controller in order to check Servomotor operation and execute simple positioning operations.

**Preparations**

Confirm the following conditions before you perform program jogging.

- The parameters must not be write prohibited.
- The main circuit power supply must be ON.
- There must be no alarms.
- There must be no hard wire base block (HWBB).
- The servo must be OFF.
- The range of machine motion and the safe movement speed of your machine must be considered when you set the travel distance and movement speed.
- There must be no overtravel.

**Additional Information**

- You can use the functions that are applicable to position control. However, functions for motions through EtherCAT communications are disabled.
- The overtravel function is enabled.

## Program Jogging Operation Pattern

An example of a program jogging operation pattern is given below. In this example, the Servomotor direction is set to Pn000 = n.□□□0 (Use CCW as the forward direction).

| Setting of Pn530 (2530h) | Setting   | Operation Pattern  |
|--------------------------|---|--|
| n.□□□0                   | (Waiting time → Forward travel distance) × Number of movements  | <p>Number of movements (Pn536)</p> <p>Movement speed<br/>         •Rotary Servomotor: Pn533<br/>         •Linear Servomotor: Pn585</p> <p>Speed 0</p> <p>Travel distance (Pn531)</p> <p>Waiting time (Pn535)</p> <p>Acceleration/ deceleration time (Pn534)</p>                                    |
| n.□□□1                   | (Waiting time → Reverse by travel distance) × Number of movements   | <p>Number of movements (Pn536)</p> <p>Speed 0</p> <p>Movement speed<br/>         •Rotary Servomotor: Pn533<br/>         •Linear Servomotor: Pn585</p> <p>Travel distance (Pn531)</p> <p>Waiting time (Pn535)</p> <p>Acceleration/ deceleration time (Pn534)</p>                                    |
| n.□□□2                   | (Waiting time → Forward by travel distance) × Number of movements → (Waiting time → Reverse by travel distance) × Number of movements | <p>Number of movements (Pn536)</p> <p>Number of movements (Pn536)</p> <p>Speed 0</p> <p>Movement speed<br/>         •Rotary Servomotor: Pn533<br/>         •Linear Servomotor: Pn585</p> <p>Travel distance (Pn531)</p> <p>Waiting time (Pn535)</p> <p>Acceleration/ deceleration time (Pn534)</p> |
| n.□□□3                   | (Waiting time → Reverse by travel distance) × Number of movements → (Waiting time → Forward by travel distance) × Number of movements | <p>Number of movements (Pn536)</p> <p>Number of movements (Pn536)</p> <p>Speed 0</p> <p>Movement speed<br/>         •Rotary Servomotor: Pn533<br/>         •Linear Servomotor: Pn585</p> <p>Travel distance (Pn531)</p> <p>Waiting time (Pn535)</p> <p>Acceleration/ deceleration time (Pn534)</p> |

Continued on next page.

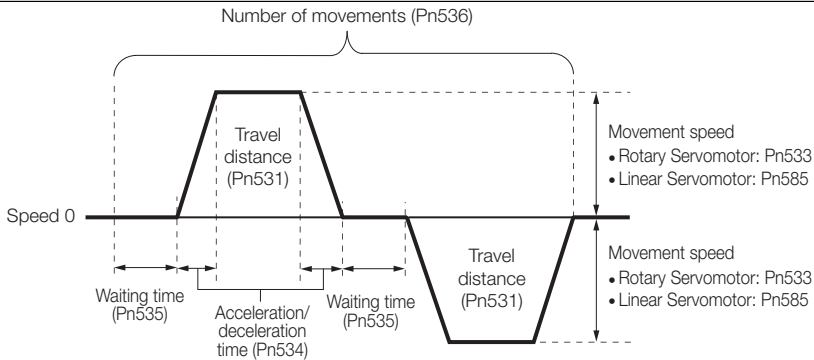
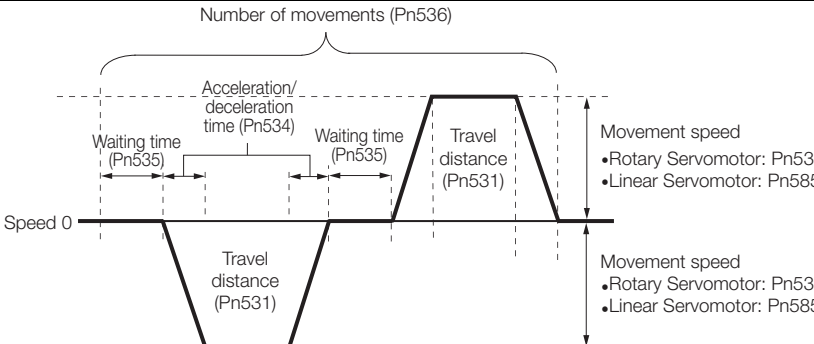

Continued from previous page.

| Setting of Pn530 (2530h) | Setting   | Operation Pattern   |
|--------------------------|---|---|
| n.□□□4                   | (Waiting time → Forward by travel distance → Waiting time → Reverse by travel distance) × Number of movements |   |
| n.□□□5                   | (Waiting time → Reverse by travel distance → Waiting time → Forward by travel distance) × Number of movements |  |

**Information**

If Pn530 is set to n.□□□0, n.□□□1, n.□□□4, or n.□□□5, you can set Pn536 (Program Jogging Number of Movements) to 0 to perform infinite time operation. You cannot use infinite time operation if Pn530 is set to n.□□□2 or n.□□□3. If you perform infinite time operation from the Digital Operator, press the **JOG/SVON** Key to turn OFF the servo to end infinite time operation.

## Related Parameters

Use the following parameters to set the program jogging operation pattern. Do not change the settings while the program jogging operation is being executed.

- Rotary Servomotors



|                  |  |                     |                 |              |                |        |
|------------------|--|---------------------|-----------------|--------------|----------------|--------|
| Pn530<br>(2530h) | Program Jogging-Related Selections             |                     |                 | Speed        | Position       | Torque |
|                  | Setting Range                                  | Setting Unit        | Default Setting | When Enabled | Classification |        |
|                  | 0000 to 0005                                   | –                   | 0000            | Immediately  | Setup          |        |
| Pn531<br>(2531h) | Program Jogging Travel Distance                |                     |                 | Speed        | Position       | Torque |
|                  | Setting Range                                  | Setting Unit        | Default Setting | When Enabled | Classification |        |
|                  | 1 to 1,073,741,824                             | 1 reference unit    | 32,768          | Immediately  | Setup          |        |
| Pn533<br>(2533h) | Program Jogging Movement Speed                 |                     |                 | Speed        | Position       | Torque |
|                  | Setting Range                                  | Setting Unit        | Default Setting | When Enabled | Classification |        |
|                  | 1 to 10,000                                    | 1 min <sup>-1</sup> | 500             | Immediately  | Setup          |        |
| Pn534<br>(2534h) | Program Jogging Acceleration/Deceleration Time |                     |                 | Speed        | Position       | Torque |
|                  | Setting Range                                  | Setting Unit        | Default Setting | When Enabled | Classification |        |
|                  | 2 to 10,000                                    | 1 ms                | 100             | Immediately  | Setup          |        |
| Pn535<br>(2535h) | Program Jogging Waiting Time                   |                     |                 | Speed        | Position       | Torque |
|                  | Setting Range                                  | Setting Unit        | Default Setting | When Enabled | Classification |        |
|                  | 0 to 10,000                                    | 1 ms                | 100             | Immediately  | Setup          |        |
| Pn536<br>(2536h) | Program Jogging Number of Movements            |                     |                 | Speed        | Position       | Torque |
|                  | Setting Range                                  | Setting Unit        | Default Setting | When Enabled | Classification |        |
|                  | 0 to 1,000                                     | 1                   | 1               | Immediately  | Setup          |        |

- Linear Servomotors

|                  |  |                  |                 |              |                |       |
|------------------|--|------------------|-----------------|--------------|----------------|-------|
| Pn530<br>(2530h) | Program Jogging-Related Selections             |                  |                 | Speed        | Position       | Force |
|                  | Setting Range                                  | Setting Unit     | Default Setting | When Enabled | Classification |       |
|                  | 0000 to 0005                                   | –                | 0000            | Immediately  | Setup          |       |
| Pn531<br>(2531h) | Program Jogging Travel Distance                |                  |                 | Speed        | Position       | Force |
|                  | Setting Range                                  | Setting Unit     | Default Setting | When Enabled | Classification |       |
|                  | 1 to 1,073,741,824                             | 1 reference unit | 32,768          | Immediately  | Setup          |       |
| Pn585<br>(2585h) | Program Jogging Movement Speed                 |                  |                 | Speed        | Position       | Force |
|                  | Setting Range                                  | Setting Unit     | Default Setting | When Enabled | Classification |       |
|                  | 1 to 10,000                                    | 1 mm/s           | 50              | Immediately  | Setup          |       |
| Pn534<br>(2534h) | Program Jogging Acceleration/Deceleration Time |                  |                 | Speed        | Position       | Force |
|                  | Setting Range                                  | Setting Unit     | Default Setting | When Enabled | Classification |       |
|                  | 2 to 10,000                                    | 1 ms             | 100             | Immediately  | Setup          |       |
| Pn535<br>(2535h) | Program Jogging Waiting Time                   |                  |                 | Speed        | Position       | Force |
|                  | Setting Range                                  | Setting Unit     | Default Setting | When Enabled | Classification |       |
|                  | 0 to 10,000                                    | 1 ms             | 100             | Immediately  | Setup          |       |
| Pn536<br>(2536h) | Program Jogging Number of Movements            |                  |                 | Speed        | Position       | Force |
|                  | Setting Range                                  | Setting Unit     | Default Setting | When Enabled | Classification |       |
|                  | 0 to 1,000                                     | 1                | 1               | Immediately  | Setup          |       |

## Applicable Tools

The following table lists the tools that you can use to perform program jogging.

| Tool             | Fn No./Function Name                     | Reference  |
|------------------|--|--|
| Digital Operator | Fn004                                    |  Σ-7-Series Digital Operator Operating Manual (Manual No.: SIEP S800001 33) |
| SigmaWin+        | <b>Operation - Program JOG Operation</b> |  Operating Procedure on page 8-17   |

## Operating Procedure

Use the following procedure for a program jog operation.

1. Click the  Servo Drive Button in the workspace of the Main Window of the SigmaWin+.
2. Select **JOG Program** in the Menu Dialog Box.  
The Jog Program Dialog Box will be displayed.
3. Read the warnings and then click the **OK** Button.

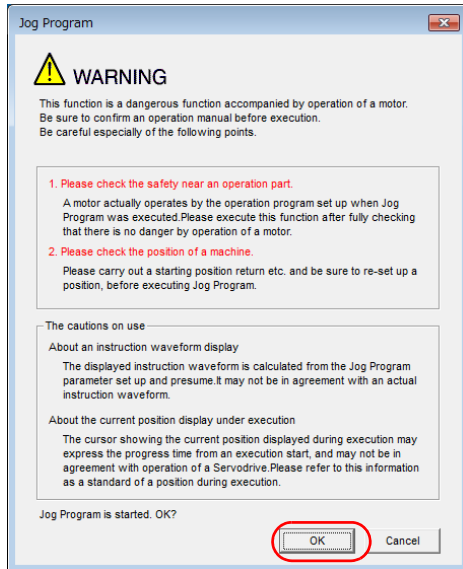

4. Set the operating conditions, click the **Apply** Button, and then click the **Run** Button.  
A graph of the operation pattern will be displayed.

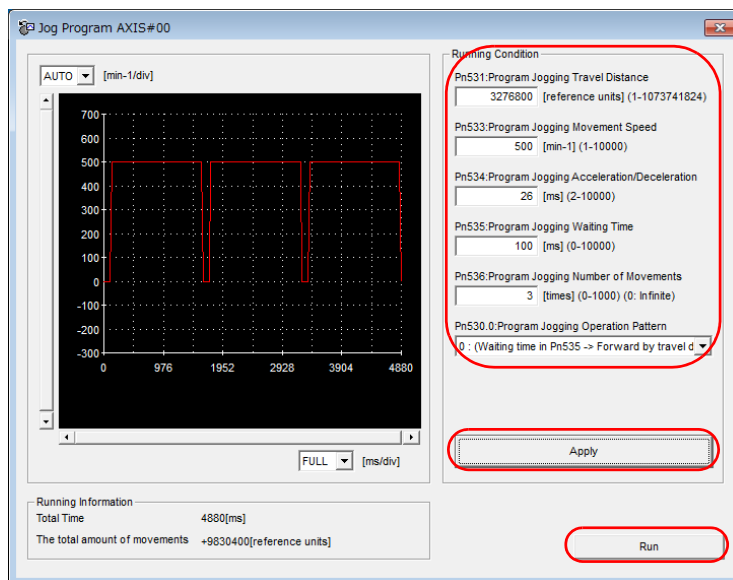

- Click the **Servo ON** Button and then the **Execute** Button. The program jogging operation will be executed.

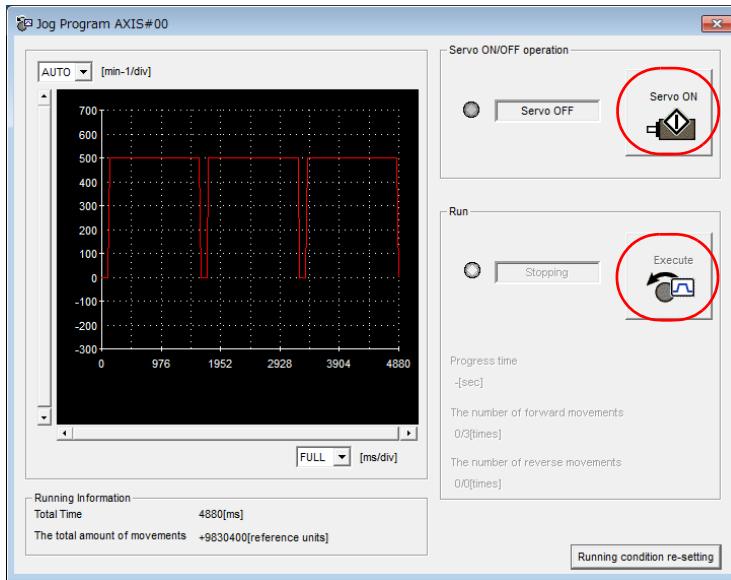

## ⚠ CAUTION

- Be aware of the following points if you cancel the program jogging operation while the motor is operating.
  - If you cancel operation with the **Servo OFF** Button, the motor will stop according to setting of the Servo OFF stopping method (Pn001 = n.□□□X).
  - If you cancel operation with the **Cancel** Button, the motor will decelerate to a stop and then enter a zero-clamped state.

This concludes the program jogging procedure.

## 8.6.2 Origin Search

The origin search operation positions the motor to phase C of the encoder and then clamps it there.

Even when using fully-closed loop control the motor is positioned to phase C of the encoder, and not to the external encoder origin.

The overtravel function is disabled during an origin search.

### CAUTION

- Make sure that the load is not coupled when you execute an origin search. Since the P-OT (Forward Drive Prohibit Input) signal and N-OT (Reverse Drive Prohibit Input) signal are disabled during an origin search, the machine may be damaged by exceeding its movement limits.

Use an origin search when it is necessary to align encoder phase C of the servomotor with the machine origin. The following speeds are used for origin searches.

- Rotary Servomotors: 60 min<sup>-1</sup>
- Linear Servomotors: 15 mm/s

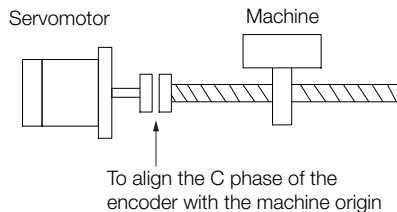

## Preparations

Confirm the following conditions before you start an origin search.

- The parameters must not be write prohibited.
- The main circuit power supply must be ON.
- There must be no alarms.
- There must be no hard wire base block (HWBB).
- The servo must be OFF.

## Applicable Tools

The following table lists the tools that you can use to perform an origin search.

| Tool             | Fn No./Function Name                   | Reference  |
|------------------|--|--|
| Digital Operator | Fn003                                  | Σ-7-Series Digital Operator Operating Manual (Manual No.: SIEP S800001 33) |
| SigmaWin+        | <b>Encoder Setting - Search Origin</b> | Operating Procedure on page 8-19   |

## Operating Procedure

Use the following procedure to perform an origin search.

1. Click the Servo Drive Button in the workspace of the Main Window of the SigmaWin+.
2. Select **Search Origin** in the Menu Dialog Box. The Origin Search Dialog Box will be displayed.

3. Read the warnings and then click the OK Button.

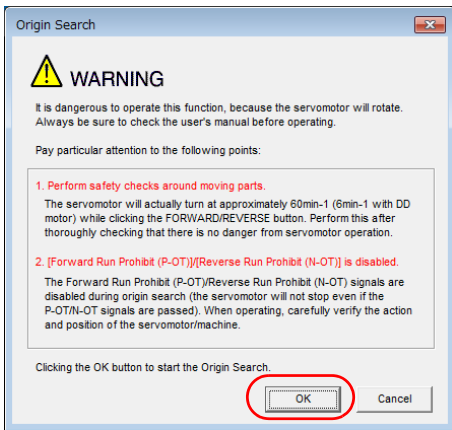

4. Click the Servo ON Button.

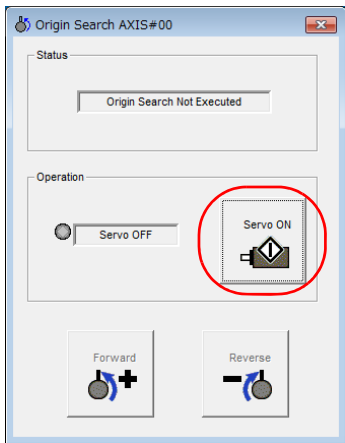

5. Click the Forward Button or the Reverse Button.  
An origin search will be performed only while you hold down the mouse button. The motor will stop when the origin search has been completed.

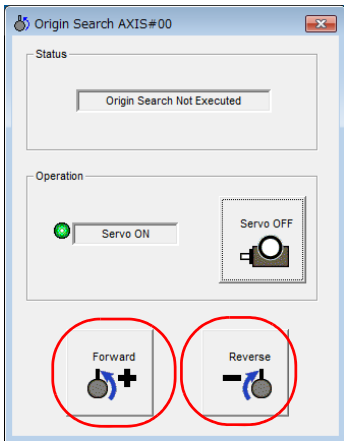

This concludes the origin search procedure.

## 8.6.3 Test without a Motor

A test without a motor is used to check the operation of the host controller and peripheral devices by simulating the operation of the Servomotor in the SERVOPACK, i.e., without actually operating a Servomotor. This test allows you to check wiring, debug the system, and verify parameters to shorten the time required for setup work and to prevent damage to the machine that may result from possible malfunctions. The operation of the motor can be checked with this test regardless of whether the motor is actually connected or not.

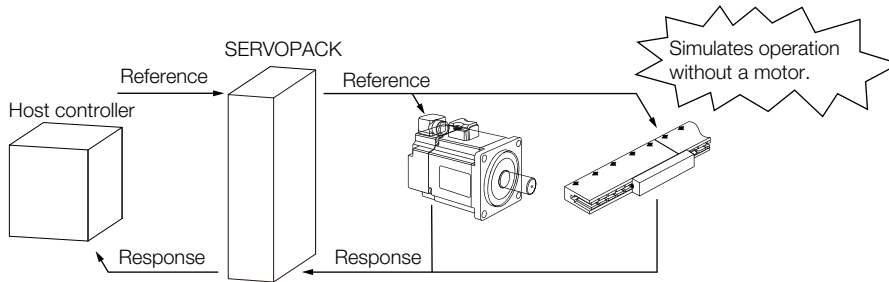

Use Pn00C = n.□□□X to enable or disable the test without a motor.

| Parameter        | Meaning                     | When Enabled  | Classification |
|------------------|-----------------------------|---------------|----------------|
| Pn00C<br>(200Ch) | n.□□□0<br>(default setting) | After restart | Setup          |
|                  | n.□□□1                      |               |                |

**Information** An asterisk is displayed on the status display of the Digital Operator while a test without a motor is being executed.

## Motor Information and Encoder Information

The motor and encoder information is used during tests without a motor. The source of the information depends on the device connection status.

### • Rotary Servomotor

| Motor Connection Status | Information That Is Used   | Source of Information   |
|-------------------------|--|---|
| Connected               | Motor information <ul style="list-style-type: none"> <li>Rated motor speed</li> <li>Maximum motor speed</li> </ul> | Information in the motor that is connected  |
|                         | Encoder information <ul style="list-style-type: none"> <li>Encoder resolution</li> <li>Encoder type</li> </ul>     |   |
| Not connected           | Motor information <ul style="list-style-type: none"> <li>Rated motor speed</li> <li>Maximum motor speed</li> </ul> | <ul style="list-style-type: none"> <li>Setting of Pn000 = n.X□□□ (Rotary/Linear Startup Selection When Encoder Is Not Connected)</li> <li>Rated motor speed and maximum motor speed<br/>The values previously saved in the SERVOPACK will be used for the rated motor speed and maximum motor speed.</li> </ul> Use the monitor displays (Un020: Rated Motor Speed and Un021: Maximum Motor Speed) to check the values. |
|                         | Encoder information <ul style="list-style-type: none"> <li>Encoder resolution</li> <li>Encoder type</li> </ul>     | <ul style="list-style-type: none"> <li>Encoder resolution: Setting of Pn00C = n.□□X□ (Encoder Resolution for Tests without a Motor)</li> <li>Encoder type: Setting of Pn00C = n.□X□□ (Encoder Type Selection for Tests without a Motor)</li> </ul>  |

• Linear Servomotors

| Motor Connection Status | Information That Is Used  | Source of Information   |
|-------------------------|---|---|
| Connected               | Motor information   | Information in the motor that is connected  |
|                         | Linear encoder information<br>• Resolution<br>• Encoder pitch<br>• Encoder type | Information in the linear encoder that is connected   |
| Not connected           | Motor information   | Setting of Pn000 = n.X□□□ (Rotary/Linear Startup Selection When Encoder Is Not Connected)   |
|                         | Linear encoder information<br>• Resolution<br>• Encoder pitch<br>• Encoder type | • Resolution: 256<br>• Encoder pitch: Setting of Pn282 (Linear Encoder Pitch)<br>• Encoder type: Setting of Pn00C = n.□X□□ (Encoder Type Selection for Tests without a Motor) |

• Related Parameters

| Parameter        |                             | Meaning   | When Enabled  | Classification |
|------------------|-----------------------------|---|---------------|----------------|
| Pn000<br>(2000h) | n.0□□□<br>(default setting) | When an encoder is not connected, start as SERVOPACK for Rotary Servomotor. | After restart | Setup          |
|                  | n.1□□□                      | When an encoder is not connected, start as SERVOPACK for Linear Servomotor. |               |                |

|                  |                      |              |                 |               |                                |                                   |                                |
|------------------|----------------------|--------------|-----------------|---------------|--------------------------------|-----------------------------------|--------------------------------|
| Pn282<br>(2282h) | Linear Encoder Pitch |              |                 |               | <input type="checkbox"/> Speed | <input type="checkbox"/> Position | <input type="checkbox"/> Force |
|                  | Setting Range        | Setting Unit | Default Setting | When Enabled  | Classification                 |                                   |                                |
|                  | 0 to 6,553,600       | 0.01 μm      | 0               | After restart | Setup                          |                                   |                                |

| Parameter        |                             | Meaning  | When Enabled  | Classification |
|------------------|-----------------------------|--|---------------|----------------|
| Pn00C<br>(200Ch) | n.□□0□<br>(default setting) | Use 13 bits as encoder resolution for tests without a motor. | After restart | Setup          |
|                  | n.□□1□                      | Use 20 bits as encoder resolution for tests without a motor. |               |                |
|                  | n.□□2□                      | Use 22 bits as encoder resolution for tests without a motor. |               |                |
|                  | n.□□3□                      | Use 24 bits as encoder resolution for tests without a motor. |               |                |
|                  | n.□0□□<br>(default setting) | Use an incremental encoder for tests without a motor.        |               |                |
|                  | n.□1□□                      | Use an absolute encoder for tests without a motor.           |               |                |

## Motor Position and Speed Responses

For a test without a motor, the following responses are simulated for references from the host controller according to the gain settings for position or speed control.

- Servomotor position
- Motor speed

The load model will be for a rigid system with the moment of inertia ratio that is set in Pn103.



## Restrictions

The following functions cannot be used during the test without a motor.

- Regeneration and dynamic brake operation
  - Brake output signal
- Refer to the following section for information on confirming the brake output signal.

☞ 10.2.3 I/O Signals Status Monitor on page 10-5

- Items marked with “x” in the following utility function table

| Button in Menu Dialog Box | SigmaWin+  | Digital Operator       |  | Executable?         |                 | Reference  |
|---------------------------|--|------------------------|--|---------------------|-----------------|------------|
|                           | SigmaWin+ Function Name                                | Fn No.                 | Utility Function Name  | Motor Not Connected | Motor Connected |            |
| Basic Functions           | Initialize *1  | Fn005                  | Initializing Parameters  | ○                   | ○               | page 6-9   |
|                           | Software Reset   | Fn030                  | Software Reset   | ○                   | ○               | page 7-35  |
|                           | Product Information                                    | Fn011                  | Display Servomotor Model   | ○                   | ○               | page 10-2  |
|                           |  | Fn012                  | Display Software Version   | ○                   | ○               |            |
|                           |  | Fn01E                  | Display SERVOPACK and Servomotor IDs                             | ○                   | ○               |            |
| Fn01F                     | Display Servomotor ID from Feedback Option Module      | ○                      | ○  |                     |                 |            |
| Encoder Setting           | Reset Absolute Encoder                                 | Fn008                  | Reset Absolute Encoder   | ×                   | ○               | page 6-49  |
|                           | Multi-turn Limit Setup                                 | Fn013                  | Multiturn Limit Setting after Multiturn Limit Disagreement Alarm | ×                   | ○               | page 7-31  |
|                           | Search Origin *2                                       | Fn003                  | Origin Search  | ○                   | ○               | page 8-19  |
|                           | Zero Point Position Setting                            | Fn020                  | Set Absolute Linear Encoder Origin                               | ×                   | ○               | page 6-51  |
|                           | Polarity Detection                                     | Fn080                  | Polarity Detection   | ×                   | ×               | page 6-22  |
| Trouble-shooting          | Display Alarm  | Fn000                  | Display Alarm History  | ○                   | ○               | page 15-42 |
|                           |  | Fn006                  | Clear Alarm History  | ○                   | ○               | page 15-43 |
|                           |  | Fn014                  | Reset Option Module Configuration Error                          | ○                   | ○               |            |
| Reset Motor Type Alarm    | Fn021  | Reset Motor Type Alarm | ○  | ○                   | –               |            |
| Operation                 | Jog  | Fn002                  | Jog  | ○                   | ○               | page 8-7   |
|                           | Program JOG Operation                                  | Fn004                  | Jog Program  | ○                   | ○               | page 8-13  |
| Tuning                    | Tuning - Autotuning without Host Reference             | Fn201                  | Advanced Autotuning without Reference                            | ×                   | ×               | page 9-24  |
|                           | Tuning - Autotuning with Host Reference                | Fn202                  | Advanced Autotuning with Reference                               | ×                   | ×               | page 9-35  |
|                           | Tuning - Custom Tuning                                 | Fn203                  | One-Parameter Tuning   | ×                   | ×               | page 9-42  |
|                           | Tuning - Custom Tuning - Adjust Anti-resonance Control | Fn204                  | Adjust Anti-resonance Control                                    | ×                   | ×               | page 9-50  |
|                           | Tuning - Custom Tuning - Vibration Suppression         | Fn205                  | Vibration Suppression  | ×                   | ×               | page 9-55  |
|                           | Response Level Setting                                 | Fn200                  | Tuning-less Level Setting  | ×                   | ×               | page 9-16  |
| Diagnostic                | Easy FFT   | Fn206                  | Easy FFT   | ×                   | ×               | page 9-93  |

Continued on next page.

## 8.6 Convenient Function to Use during Trial Operation

### 8.6.3 Test without a Motor

Continued from previous page.

| SigmaWin+                 |  | Digital Operator |   | Executable?         |                 | Reference |
|---------------------------|--|------------------|---|---------------------|-----------------|-----------|
| Button in Menu Dialog Box | SigmaWin+ Function Name                    | Fn No.           | Utility Function Name                                 | Motor Not Connected | Motor Connected |           |
| Others                    | Adjust the Analog Monitor Output           | Fn00C            | Adjust Analog Monitor Output Offset                   | ○                   | ○               | page 10-9 |
|                           |  | Fn00D            | Adjust Analog Monitor Output Gain                     | ○                   | ○               |           |
|                           | Adjust the Motor Current Detection Offsets | Fn00E            | Autotune Motor Current Detection Signal Offset        | ×                   | ○               | page 7-41 |
|                           |  | Fn00F            | Manually Adjust Motor Current Detection Signal Offset | ×                   | ○               |           |
|                           | Initialize Vibration Detection Level       | Fn01B            | Initialize Vibration Detection Level                  | ×                   | ×               | page 7-37 |
|                           | Write Prohibited Setting                   | Fn010            | Write Prohibition Setting                             | ○                   | ○               | page 6-6  |

\*1. An **Initialize** Button will be displayed in the Parameter Editing Dialog Box.

\*2. Cannot be used when connecting a Linear Servomotor.

# Tuning

# 9

This chapter provides information on the flow of tuning, details on tuning functions, and related operating procedures.

|            |   |             |
|------------|---|-------------|
| <b>9.1</b> | <b>Overview and Flow of Tuning</b>                              | <b>9-4</b>  |
| 9.1.1      | Tuning Functions  | 9-5         |
| 9.1.2      | Diagnostic Tool   | 9-6         |
| <b>9.2</b> | <b>Monitoring Methods</b>                                       | <b>9-7</b>  |
| <b>9.3</b> | <b>Precautions to Ensure Safe Tuning</b>                        | <b>9-8</b>  |
| 9.3.1      | Overtravel Settings   | 9-8         |
| 9.3.2      | Torque Limit Settings   | 9-8         |
| 9.3.3      | Setting the Position Deviation Overflow Alarm Level             | 9-8         |
| 9.3.4      | Vibration Detection Level Setting                               | 9-10        |
| 9.3.5      | Setting the Position Deviation Overflow Alarm Level at Servo ON | 9-10        |
| <b>9.4</b> | <b>Tuning-less Function</b>                                     | <b>9-12</b> |
| 9.4.1      | Application Restrictions  | 9-12        |
| 9.4.2      | Operating Procedure   | 9-13        |
| 9.4.3      | Troubleshooting Alarms  | 9-14        |
| 9.4.4      | Parameters Disabled by Tuning-less Function                     | 9-15        |
| 9.4.5      | Automatically Adjusted Function Setting                         | 9-15        |
| 9.4.6      | Related Parameters  | 9-15        |
| <b>9.5</b> | <b>Estimating the Moment of Inertia</b>                         | <b>9-16</b> |
| 9.5.1      | Outline   | 9-16        |
| 9.5.2      | Restrictions  | 9-16        |
| 9.5.3      | Applicable Tools  | 9-17        |
| 9.5.4      | Operating Procedure   | 9-17        |

**9.6 Autotuning without Host Reference . . . . . 9-24**

9.6.1 Outline . . . . . 9-24  
9.6.2 Restrictions . . . . . 9-25  
9.6.3 Applicable Tools . . . . . 9-26  
9.6.4 Operating Procedure . . . . . 9-26  
9.6.5 Troubleshooting Problems in Autotuning  
without a Host Reference . . . . . 9-30  
9.6.6 Automatically Adjusted Function Settings . . . . . 9-32  
9.6.7 Related Parameters . . . . . 9-34

**9.7 Autotuning with a Host Reference . . . . . 9-35**

9.7.1 Outline . . . . . 9-35  
9.7.2 Restrictions . . . . . 9-36  
9.7.3 Applicable Tools . . . . . 9-36  
9.7.4 Operating Procedure . . . . . 9-37  
9.7.5 Troubleshooting Problems in Autotuning  
with a Host Reference . . . . . 9-40  
9.7.6 Automatically Adjusted Function Settings . . . . . 9-40  
9.7.7 Related Parameters . . . . . 9-41

**9.8 Custom Tuning . . . . . 9-42**

9.8.1 Outline . . . . . 9-42  
9.8.2 Preparations . . . . . 9-42  
9.8.3 Applicable Tools . . . . . 9-43  
9.8.4 Operating Procedure . . . . . 9-43  
9.8.5 Automatically Adjusted Function Settings . . . . . 9-48  
9.8.6 Tuning Example for Tuning Mode 2 or 3 . . . . . 9-48  
9.8.7 Related Parameters . . . . . 9-49

**9.9 Anti-Resonance Control Adjustment . . . . . 9-50**

9.9.1 Outline . . . . . 9-50  
9.9.2 Preparations . . . . . 9-50  
9.9.3 Applicable Tools . . . . . 9-51  
9.9.4 Operating Procedure . . . . . 9-51  
9.9.5 Related Parameters . . . . . 9-53  
9.9.6 Suppressing Different Vibration Frequencies  
with Anti-resonance Control . . . . . 9-53

**9.10 Vibration Suppression . . . . . 9-55**

9.10.1 Outline . . . . . 9-55  
9.10.2 Preparations . . . . . 9-56  
9.10.3 Applicable Tools . . . . . 9-56  
9.10.4 Operating Procedure . . . . . 9-56  
9.10.5 Setting Combined Functions . . . . . 9-58  
9.10.6 Related Parameters . . . . . 9-58

**9.11 Speed Ripple Compensation . . . . . 9-59**

9.11.1 Outline . . . . . 9-59  
9.11.2 Setting Up Speed Ripple Compensation . . . . . 9-59  
9.11.3 Setting Parameters . . . . . 9-63

**9.12 Additional Adjustment Functions . . . . . 9-65**

- 9.12.1 Gain Switching . . . . . 9-65
- 9.12.2 Friction Compensation . . . . . 9-68
- 9.12.3 Gravity Compensation . . . . . 9-69
- 9.12.4 Current Control Mode Selection . . . . . 9-70
- 9.12.5 Current Gain Level Setting . . . . . 9-71
- 9.12.6 Speed Detection Method Selection . . . . . 9-71
- 9.12.7 Speed Feedback Filter . . . . . 9-71
- 9.12.8 Backlash Compensation . . . . . 9-72

**9.13 Manual Tuning . . . . . 9-77**

- 9.13.1 Tuning the Servo Gains . . . . . 9-77
- 9.13.2 Compatible Adjustment Functions . . . . . 9-87

**9.14 Diagnostic Tools . . . . . 9-91**

- 9.14.1 Mechanical Analysis . . . . . 9-91
- 9.14.2 Easy FFT . . . . . 9-93

# 9.1 Overview and Flow of Tuning

Tuning is performed to optimize response by adjusting the servo gains in the SERVOPACK.

The servo gains are set using a combination of parameters, such as parameters for the speed loop gain, position loop gain, filters, friction compensation, and moment of inertia ratio. These parameters influence each other, so you must consider the balance between them.

The servo gains are set to stable settings by default. Use the various tuning functions to increase the response even further for the conditions of your machine.

The basic tuning procedure is shown in the following flowchart. Make suitable adjustments considering the conditions and operating requirements of your machine.

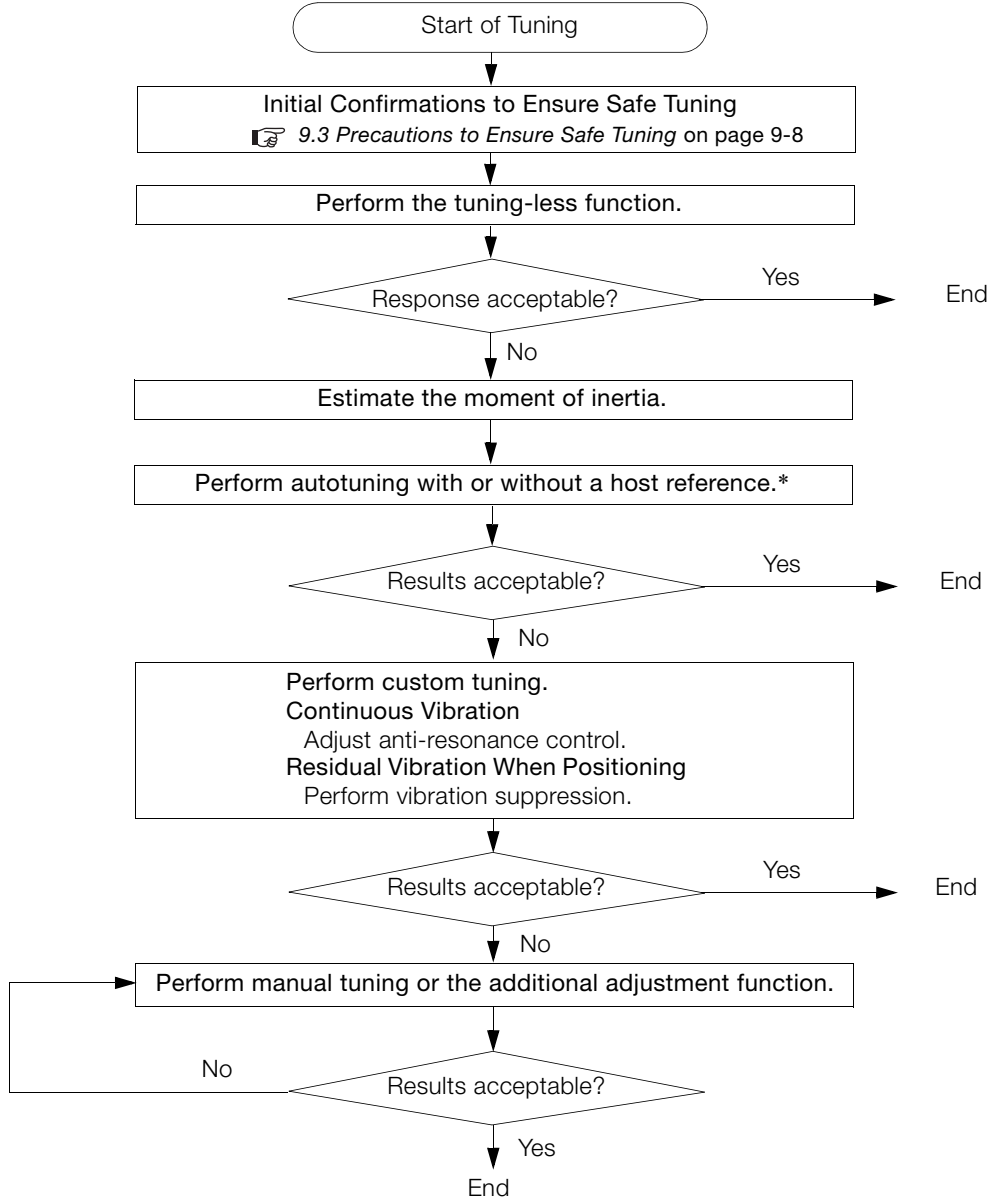

\* If possible, perform autotuning with a host reference.  
 If a host controller is not available, set an operation pattern that is as close as possible to the host reference and perform autotuning without a host reference.  
 If an operation pattern that is close to the host reference is not possible, perform autotuning with a host reference while performing program jogging.

## 9.1.1 Tuning Functions

The following table provides an overview of the tuning functions.

| Tuning Function                   | Outline  | Applicable Control Methods                         | Reference |
|-----------------------------------|--|--|-----------|
| Tuning-less Function              | This automatic adjustment function is designed to enable stable operation without servo tuning. This function can be used to obtain a stable response regardless of the type of machine or changes in the load. You can use it with the default settings.  | Speed control or position control                  | page 9-12 |
| Moment of Inertia Estimation      | The moment of inertia ratio is calculated by operating the Servomotor a few times.<br>The moment of inertia ratio that is calculated here is used in other tuning functions.   | Speed control, position control, or torque control | page 9-16 |
| Autotuning without Host Reference | The following parameters are automatically adjusted in the internal references in the SERVO-PACK during automatic operation. <ul style="list-style-type: none"> <li>• Gains (e.g., position loop gain and speed loop gain)</li> <li>• Filters (torque reference filter and notch filters)</li> <li>• Friction compensation</li> <li>• Anti-resonance control</li> <li>• Vibration suppression</li> </ul>   | Speed control or position control                  | page 9-24 |
| Autotuning with Host Reference    | The following parameters are automatically adjusted with the position reference input from the host controller while the machine is in operation. You can use this function for fine-tuning after you perform autotuning without a host reference. <ul style="list-style-type: none"> <li>• Gains (e.g., position loop gain and speed loop gain)</li> <li>• Filters (torque reference filter and notch filters)</li> <li>• Friction compensation</li> <li>• Anti-resonance control</li> <li>• Vibration suppression</li> </ul> | Position control                                   | page 9-35 |
| Custom Tuning                     | The following parameters are adjusted with the position reference or speed reference input from the host controller while the machine is in operation. <ul style="list-style-type: none"> <li>• Gains (e.g., position loop gain and speed loop gain)</li> <li>• Filters (torque reference filter and notch filters)</li> <li>• Friction compensation</li> <li>• Anti-resonance control</li> </ul>  | Speed control or position control                  | page 9-42 |
| Anti-resonance Control Adjustment | This function effectively suppresses continuous vibration.   | Speed control or position control                  | page 9-50 |
| Vibration Suppression             | This function effectively suppresses residual vibration if it occurs when positioning.   | Position control                                   | page 9-55 |
| Speed Ripple Compensation         | This function reduces the ripple in the motor speed.   | Speed control, position control, or torque control | page 9-59 |
| Additional Adjustment Function    | This function combines autotuning with custom tuning. You can use it to improve adjustment results.  | Depends on the functions that you use.             | page 9-65 |
| Manual Tuning                     | You can manually adjust the servo gains to adjust the response.  | Speed control, position control, or torque control | page 9-77 |

---

## 9.1.2 Diagnostic Tool

---

You can use the following tools to measure the frequency characteristics of the machine and set notch filters.

| Diagnostic Tool     | Outline  | Applicable Control Methods                         | Reference |
|---------------------|--|--|-----------|
| Mechanical Analysis | The machine is subjected to vibration to detect resonance frequencies. The measurement results are displayed as waveforms or numeric data. | Speed control, position control, or torque control | page 9-91 |
| Easy FFT            | The machine is subjected to vibration to detect resonance frequencies. The measurement results are displayed only as numeric data.         | Speed control, position control, or torque control | page 9-93 |



## 9.2 Monitoring Methods

You can use the data tracing function of the SigmaWin+ or the analog monitor signals of the SERVOPACK for monitoring. If you perform custom tuning or manual tuning, always use the above functions to monitor the machine operating status and SERVOPACK signal waveform while you adjust the servo gains.

Check the adjustment results with the following response waveforms.

- Position Control

| Item                     | Unit              |                   |
|--------------------------|-------------------|-------------------|
|                          | Rotary Servomotor | Linear Servomotor |
| Torque reference         | %                 |                   |
| Feedback speed           | min <sup>-1</sup> | mm/s              |
| Position reference speed | min <sup>-1</sup> | mm/s              |
| Position deviation       | Reference units   |                   |

- Speed Control

| Item             | Unit              |                   |
|------------------|-------------------|-------------------|
|                  | Rotary Servomotor | Linear Servomotor |
| Torque reference | %                 |                   |
| Feedback speed   | min <sup>-1</sup> | mm/s              |
| Reference speed  | min <sup>-1</sup> | mm/s              |

- Torque Control

| Item             | Unit              |                   |
|------------------|-------------------|-------------------|
|                  | Rotary Servomotor | Linear Servomotor |
| Torque reference | %                 |                   |
| Feedback speed   | min <sup>-1</sup> | mm/s              |

## 9.3 Precautions to Ensure Safe Tuning

### CAUTION

- Observe the following precautions when you perform tuning.
  - Do not touch the rotating parts of the motor when the servo is ON.
  - Before starting the Servomotor, make sure that an emergency stop can be performed at any time.
  - Make sure that trial operation has been successfully performed without any problems.
  - Provide an appropriate stopping device on the machine to ensure safety.

Perform the following settings in a way that is suitable for tuning.

### 9.3.1 Overtravel Settings

Overtravel settings are made to force the Servomotor to stop for a signal input from a limit switch when a moving part of the machine exceeds the safe movement range.

Refer to the following section for details.

 6.10 *Overtravel and Related Settings* on page 6-25

### 9.3.2 Torque Limit Settings

You can limit the torque that is output by the Servomotor based on calculations of the torque required for machine operation. You can use torque limits to reduce the amount of shock applied to the machine when problems occur, such as collisions or interference. If the torque limit is lower than the torque that is required for operation, overshooting or vibration may occur. Refer to the following section for details.

 7.6 *Selecting Torque Limits* on page 7-23

### 9.3.3 Setting the Position Deviation Overflow Alarm Level

The position deviation overflow alarm is a protective function that is enabled when the SERVOPACK is used in position control.

If the alarm level is set to a suitable value, the SERVOPACK will detect excessive position deviation and will stop the Servomotor if the Servomotor operation does not agree with the reference.

The position deviation is the difference between the position reference value and the actual position.

You can calculate the position deviation from the position loop gain (Pn102) and the motor speed with the following formula.

• **Rotary Servomotors**

$$\text{Position deviation [reference units]} = \frac{\text{Motor speed [min}^{-1}\text{]}}{60} \times \frac{\text{Encoder resolution}^{*1}}{\text{Pn102 [0.1/s/10}^{*2}, *3]} \times \frac{\text{Denominator}}{\text{Numerator}}$$

• **Linear Servomotors**

$$\text{Position deviation [reference units]} = \frac{\text{Motor speed [mm/s]}}{\text{Pn102 [0.1/s/10}^{*2}, *3]} \times \frac{\text{Resolution}}{\text{Linear encoder pitch [\mu m]/1,000}} \times \frac{\text{Denominator}}{\text{Numerator}}$$

Position Deviation Overflow Alarm Level (Pn520) [setting unit: reference units]

- Rotary Servomotors

$$\text{Pn520} > \frac{\text{Maximum motor speed [min}^{-1}\text{]}}{60} \times \frac{\text{Encoder resolution}^{*1}}{\text{Pn102 [0.1/s]/10}^{*2, *3}} \times \frac{\text{Denominator}}{\text{Numerator}} \times \underline{\underline{(1.2 \text{ to } 2)^{*4}}}$$

- Linear Servomotors

$$\text{Pn520} > \frac{\text{Maximum motor speed [mm/s]}}{\text{Pn102 [0.1/s]/10}^{*2, *3}} \times \frac{\text{Resolution}}{\text{Linear encoder pitch [\mu m]/1,000}} \times \frac{\text{Denominator}}{\text{Numerator}} \times \underline{\underline{(1.2 \text{ to } 2)^{*4}}}$$

\*1. Refer to the following section for details.

 6.14 Setting Unit Systems on page 6-41

\*2. When model following control (Pn140 = n.□□□1) is enabled, use the setting of Pn141 (Model Following Control Gain) instead of the setting of Pn102 (Position Loop Gain).

\*3. To check the setting of Pn102 on the Digital Operator, change the parameter display setting to display all parameters (Pn00B = n.□□□1).

\*4. The underlined coefficient “× (1.2 to 2)” adds a margin to prevent an A.d00 alarm (Position Deviation Overflow) from occurring too frequently.

If you set a value that satisfies the formula, an A.d00 alarm (Position Deviation Overflow) should not occur during normal operation.

If the Servomotor operation does not agree with the reference, position deviation will occur, an error will be detected, and the motor will stop.

The following calculation example uses a Rotary Servomotor with a maximum motor speed of 6,000 and an encoder resolution of 16,777,216 (24 bits). Pn102 is set to 400.

$$\frac{\text{Denominator}}{\text{Numerator}} = \frac{1}{16}$$

$$\begin{aligned} \text{Pn520} &= \frac{6,000}{60} \times \frac{16,777,216}{400/10} \times \frac{1}{16} \times 2 \\ &= 2,621,440 \times 2 \\ &= 5,242,880 \text{ (default setting of Pn520)} \end{aligned}$$

If the acceleration/deceleration rate required for the position reference exceeds the tracking capacity of the Servomotor, the tracking delay will increase and the position deviation will no longer satisfy the above formulas. If this occurs, lower the acceleration/deceleration rate so that the Servomotor can follow the position reference or increase the position deviation overflow alarm level.

## Related Parameters

|                  |   |                  |                 |              |                |
|------------------|---|------------------|-----------------|--------------|----------------|
| Pn520<br>(2520h) | Position Deviation Overflow Alarm Level <span style="float: right;">Position</span>   |                  |                 |              |                |
|                  | Setting Range   | Setting Unit     | Default Setting | When Enabled | Classification |
|                  | 1 to 1,073,741,823  | 1 reference unit | 5,242,880       | Immediately  | Setup          |
| Pn51E<br>(251Eh) | Position Deviation Overflow Warning Level <span style="float: right;">Position</span> |                  |                 |              |                |
|                  | Setting Range   | Setting Unit     | Default Setting | When Enabled | Classification |
|                  | 10 to 100   | 1%               | 100             | Immediately  | Setup          |

## Related Alarms

| Alarm Number | Alarm Name                  | Alarm Meaning   |
|--------------|-----------------------------|---|
| A.d00        | Position Deviation Overflow | This alarm occurs if the position deviation exceeds the setting of Pn520 (2520h) (Position Deviation Overflow Alarm Level). |

## Related Warnings

| Warning Number | Warning Name                | Warning Meaning   |
|----------------|-----------------------------|---|
| A.900          | Position Deviation Overflow | This warning occurs if the position deviation exceeds the specified percentage (Pn520 × Pn51E/100). |

## 9.3.4 Vibration Detection Level Setting

You can set the vibration detection level (Pn312) to more accurately detect A.520 alarms (Vibration Alarm) and A.911 warnings (Vibration Warning) when vibration is detected during machine operation.

Set the initial vibration detection level to an appropriate value. Refer to the following section for details.

 7.10 *Initializing the Vibration Detection Level* on page 7-37

## 9.3.5 Setting the Position Deviation Overflow Alarm Level at Servo ON

If the servo is turned ON when there is a large position deviation, the Servomotor will attempt to return to the original position to bring the position deviation to 0, which may create a hazardous situation. To prevent this, you can set a position deviation overflow alarm level at servo ON to restrict operation.

The related parameters and alarms are given in the following tables.

### Related Parameters

| Pn526<br>(2526h) | Position Deviation Overflow Alarm Level at Servo ON <span style="float:right">Position</span> |                  |                 |              |                |
|------------------|---|------------------|-----------------|--------------|----------------|
|                  | Setting Range   | Setting Unit     | Default Setting | When Enabled | Classification |
|                  | 1 to 1,073,741,823  | 1 reference unit | 5,242,880       | Immediately  | Setup          |

| Pn528<br>(2528h) | Position Deviation Overflow Warning Level at Servo ON <span style="float:right">Position</span> |              |                 |              |                |
|------------------|---|--------------|-----------------|--------------|----------------|
|                  | Setting Range   | Setting Unit | Default Setting | When Enabled | Classification |
|                  | 10 to 100   | 1%           | 100             | Immediately  | Setup          |

#### • Rotary Servomotors

| Pn529<br>(2529h) | Speed Limit Level at Servo ON <span style="float:right">Position</span> |                     |                 |              |                |
|------------------|---|---------------------|-----------------|--------------|----------------|
|                  | Setting Range   | Setting Unit        | Default Setting | When Enabled | Classification |
|                  | 0 to 10,000   | 1 min <sup>-1</sup> | 10,000          | Immediately  | Setup          |

#### • Linear Servomotors

| Pn584<br>(2584h) | Speed Limit Level at Servo ON <span style="float:right">Position</span> |              |                 |              |                |
|------------------|---|--------------|-----------------|--------------|----------------|
|                  | Setting Range   | Setting Unit | Default Setting | When Enabled | Classification |
|                  | 0 to 10,000   | 1 mm/s       | 10,000          | Immediately  | Setup          |

### Related Alarms

| Alarm Number | Alarm Name  | Alarm Meaning   |
|--------------|---|---|
| A.d01        | Position Deviation Overflow Alarm at Servo ON                 | This alarm occurs if Servo ON command (Enable Operation command) is executed after the position deviation exceeded the setting of Pn526 (Excessive Position Deviation Alarm Level at Servo ON) while the servo was OFF.   |
| A.d02        | Position Deviation Overflow Alarm for Speed Limit at Servo ON | If position deviation remains in the deviation counter, the setting of Pn529 or Pn584 (Speed Limit Level at Servo ON) will limit the speed when the servo is turned ON. This alarm occurs if a position reference is input and the setting of Pn520 (Excessive Position Deviation Alarm Level) is exceeded. |

Refer to the following section for information on troubleshooting alarms.

 15.2.3 *Resetting Alarms* on page 15-41

## Related Warnings

| Warning Number | Warning Name                                    | Warning Meaning   |
|----------------|---|---|
| A.901          | Position Deviation Overflow Warning at Servo ON | This warning occurs if the servo is turned ON while the position deviation exceeds the specified percentage ( $Pn526 \times Pn528/100$ ). |

# 9.4 Tuning-less Function

The tuning-less function performs autotuning to obtain a stable response regardless of the type of machine or changes in the load. Autotuning is started when the servo is turned ON.

**CAUTION**

- The tuning-less function is disabled during torque control.
- The Servomotor may momentarily emit a sound or vibrate the first time the servo is turned ON after the Servomotor is connected to the machine.  
This sound is caused by setting the automatic notch filter. It does not indicate a problem. However, if this sound or vibration continues, manually set a function to suppress vibration (e.g., a notch filter).
- The Servomotor may vibrate if it exceeds the allowable load moment of inertia.  
If that occurs, set the tuning-less load level to 2 (Pn170 = n.2□□□) or reduce the Tuning-less Rigidity Level (Pn170 = n.□X□□).
- To ensure safety, make sure that you can perform an emergency stop at any time when you execute the tuning-less function.

## 9.4.1 Application Restrictions

The following application restrictions apply to the tuning-less function.

| Function                                 | Executable* | Remarks  |
|--|-------------|--|
| Vibration Detection Level Initialization | ○           | -  |
| Moment of Inertia Estimation             | ×           | Disable the tuning-less function (Pn170 = n.□□□0) before you execute moment of inertia estimation.   |
| Autotuning without Host Reference        | ×           | Disable the tuning-less function (Pn170 = n.□□□0) before you execute autotuning without a host reference.                                      |
| Autotuning with Host Reference           | ×           | -  |
| Custom Tuning                            | ×           | -  |
| Anti-Resonance Control Adjustment        | ×           | -  |
| Vibration Suppression                    | ×           | -  |
| Easy FFT                                 | ○           | The tuning-less function is disabled while you execute Easy FFT and then it is enabled when Easy FFT has been completed.                       |
| Friction Compensation                    | ×           | -  |
| Gain Selection                           | ×           | -  |
| Mechanical Analysis                      | ○           | The tuning-less function is disabled while you execute mechanical analysis and then it is enabled when mechanical analysis has been completed. |

\* ○: Yes ×: No

## 9.4.2 Operating Procedure

The tuning-less function is enabled in the default settings. No specific procedure is required. You can use the following parameter to enable or disable the tuning-less function.

| Parameter        |                             | Meaning   | When Enabled  | Classification |
|------------------|-----------------------------|---|---------------|----------------|
| Pn170<br>(2170h) | n.□□□0                      | Disable tuning-less function.                                       | After restart | Setup          |
|                  | n.□□□1<br>(default setting) | Enable tuning-less function.  |               |                |
|                  | n.□□0□<br>(default setting) | Use for speed control.  |               |                |
|                  | n.□□1□                      | Use for speed control and use host controller for position control. |               |                |

When you enable the tuning-less function, you can select the tuning-less type. Normally, set Pn14F to n.□□2□ (Use tuning-less type 3) (default setting). If compatibility with previous models is required, set Pn14F to n.□□0□ (Use tuning-less type 1) or n.□□1□ (Use tuning-less type 2).

| Parameter        |                             | Meaning  | When Enabled  | Classification |
|------------------|-----------------------------|--|---------------|----------------|
| Pn14F<br>(214Fh) | n.□□0□                      | Use tuning-less type 1.  | After restart | Tuning         |
|                  | n.□□1□                      | Use tuning-less type 2. (The noise level is improved more than with tuning-less type 1.) |               |                |
|                  | n.□□2□<br>(default setting) | Use tuning-less type 3.  |               |                |

### Tuning-less Level Settings

If vibration or other problems occur, change the tuning-less levels. To change the tuning-less levels, use the SigmaWin+.

#### ◆ Preparations

Check the following settings before you set the tuning-less levels.

- The tuning-less function must be enabled (Pn170 = n.□□□1).
- The test without a motor function must be disabled (Pn00C = n.□□□0).
- The Servomotor must be connected to the machine.

#### ◆ Procedure

Use the following procedure to set the tuning-less levels.

In addition to the following procedure, you can also set the parameters directly. Refer to *Related Parameters*, below, for the parameters to set.

1. Select **Setup - Response Level Setting** from the menu bar of the Main Window of the SigmaWin+.  
The Tuning-less Level Setting-Adj Dialog Box will be displayed.

- Click the ▲ or ▼ Button to adjust the tuning-less level setting. Increase the tuning-less level setting to increase the response. Decrease the tuning-less level setting to suppress vibration.

The default response level setting is 4.

| Tuning-less Level   | Description          | Remarks   |
|---------------------|----------------------|---|
| 7                   | Response level: High | You cannot select these levels if tuning-less type 1 or 2 (Pn14F = n.□□0□ or n.□□1□) is used. |
| 6                   |                      |   |
| 5                   |                      |   |
| 4 (default setting) |                      |   |
| 3                   |                      |   |
| 2                   |                      |   |
| 1                   |                      |   |
| 0                   | Response level: Low  | -   |

- Click the **Completed** Button.

The adjustment results will be saved in the SERVOPACK.



Reset the tuning-less level to the default setting when removing the Servomotor from the machine. The Servomotor may vibrate if the tuning-less level is not reset and the servo is turned ON when the Servomotor has been removed from the machine.

### ◆ Related Parameters

#### ■ Tuning-less Rigidity Level

If you use tuning-less type 1 or 2 (Pn14F = n.□□0□ or n.□□1□), set the tuning-less level to between 0 and 4 (Pn170 = n.□0□□ to n.□4□□). Do not set the tuning-less level to between 5 and 7 (Pn170 = n.□5□□ to n.□7□□).

| Parameter        | Description                 | When Enabled                                 | Classification |       |
|------------------|-----------------------------|--|----------------|-------|
| Pn170<br>(2170h) | n.□0□□                      | Tuning-less rigidity level 0 (low rigidity)  | Immediately    | Setup |
|                  | n.□1□□                      | Tuning-less rigidity level 1                 |                |       |
|                  | n.□2□□                      | Tuning-less rigidity level 2                 |                |       |
|                  | n.□3□□                      | Tuning-less rigidity level 3                 |                |       |
|                  | n.□4□□<br>(default setting) | Tuning-less rigidity level 4                 |                |       |
|                  | n.□5□□                      | Tuning-less rigidity level 5                 |                |       |
|                  | n.□6□□                      | Tuning-less rigidity level 6                 |                |       |
|                  | n.□7□□                      | Tuning-less rigidity level 7 (high rigidity) |                |       |

#### ■ Tuning-less Load Level

| Parameter        | Description                 | When Enabled             | Classification |       |
|------------------|-----------------------------|--------------------------|----------------|-------|
| Pn170<br>(2170h) | n.0□□□                      | Tuning-less load level 0 | Immediately    | Setup |
|                  | n.1□□□<br>(default setting) | Tuning-less load level 1 |                |       |
|                  | n.2□□□                      | Tuning-less load level 2 |                |       |

## 9.4.3 Troubleshooting Alarms

An A.521 alarm (Autotuning Alarm) will occur if a resonant sound occurs or if excessive vibration occurs during position control. If an alarm occurs, implement the following measures.

- Resonant Sound  
Decrease the setting of Pn170 = n.X□□□ or the setting of Pn170 = n.□X□□.
- Excessive Vibration during Position Control  
Increase the setting of Pn170 = n.X□□□ or decrease the setting of Pn170 = n.□X□□.



## 9.4.4 Parameters Disabled by Tuning-less Function

When the tuning-less function is enabled (Pn170 = n.□□□1) (default setting), the parameters in the following table are disabled.

| Item                                | Parameter Name  | Parameter Number               |
|-------------------------------------|---|--------------------------------|
| Gain-Related Parameters             | Speed Loop Gain<br>Second Speed Loop Gain                                     | Pn100 (2100h)<br>Pn104 (2104h) |
|                                     | Speed Loop Integral Time Constant<br>Second Speed Loop Integral Time Constant | Pn101 (2101h)<br>Pn105 (2105h) |
|                                     | Position Loop Gain<br>Second Position Loop Gain                               | Pn102 (2102h)<br>Pn106 (2106h) |
|                                     | Moment of Inertia Ratio   | Pn103 (2103h)                  |
| Advanced Control-Related Parameters | Friction Compensation Function Selection                                      | Pn408 (2408h) =<br>n.X□□□      |
|                                     | Anti-Resonance Control Selection  | Pn160 (2160h)=<br>n.□□□X       |
| Gain Selection-Related Parameters   | Gain Switching Selection  | Pn139 (2139h)=<br>n.□□□X       |

The tuning-less function is disabled during torque control, Easy FFT, and mechanical analysis for a vertical axis. The gain-related parameters in the above table are enabled for torque control, Easy FFT, and mechanical analysis. Of these, Pn100, Pn103, and Pn104 are enabled for torque control.

## 9.4.5 Automatically Adjusted Function Setting

You can also automatically adjust notch filters.

Normally, set Pn460 to n.□1□□ (Adjust automatically) (default setting). Vibration is automatically detected and a notch filter is set.

Set Pn460 to n.□0□□ (Do not adjust automatically) only if you do not change the setting of the notch filter before you execute the tuning-less function.

| Parameter        | Meaning                     | When Enabled | Classification |
|------------------|-----------------------------|--------------|----------------|
| Pn460<br>(2460h) | n.□0□□                      | Immediately  | Tuning         |
|                  | n.□1□□<br>(default setting) |              |                |

## 9.4.6 Related Parameters

The following parameters are automatically adjusted when you execute the tuning-less function.

Do not manually change the settings of these parameters after you have enabled the tuning-less function.

| Parameter     | Name  |
|---------------|---|
| Pn401 (2401h) | First Stage First Torque Reference Filter Time Constant |
| Pn40A (240Ah) | First Stage Notch Filter Q Value                        |
| Pn40C (240Ch) | Second Stage Notch Filter Frequency                     |
| Pn40D (240Dh) | Second Stage Notch Filter Q Value                       |

## 9.5 Estimating the Moment of Inertia

This section describes how the moment of inertia is calculated.

The moment of inertia ratio that is calculated here is used in other tuning functions. You can also estimate the moment of inertia during autotuning without a host reference. Refer to the following section for the procedure.

 9.6.4 Operating Procedure on page 9-26

### 9.5.1 Outline

The moment of inertia during operation is automatically calculated by the SERVOPACK for round-trip (forward and reverse) operation. A reference from the host controller is not used.

The moment of inertia ratio (i.e., the ratio of the load moment of inertia to the motor moment of inertia) is a basic parameter for adjusting gains. It must be set as accurately as possible.

Although the load moment of inertia can be calculated from the weight and structure of the mechanisms, doing so is very troublesome and calculating it accurately can be very difficult with the complex mechanical structures that are used these days. With an estimate of the moment of inertia, you can obtain an accurate load moment of inertia simply by running the Servomotor in the actual system in a forward and reverse direction a few times.

The motor is operated with the following specifications.

- Maximum speed:  $\pm 1,000 \text{ min}^{-1}$  (can be changed)
- Acceleration rate:  $\pm 20,000 \text{ min}^{-1}/\text{s}$  (can be changed)
- Travel distance:  $\pm 2.5$  rotations max. (can be changed)

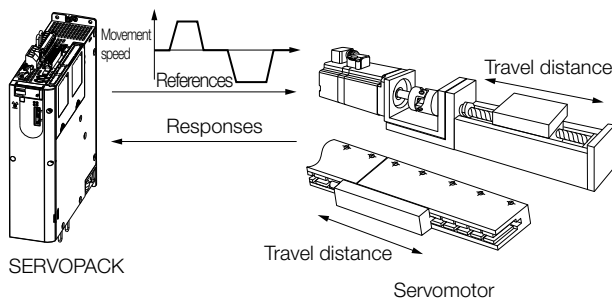

Note: Execute moment of inertia estimation after jogging to a position that ensures a suitable range of motion.

### 9.5.2 Restrictions

The following restrictions apply to estimating the moment of inertia.

#### Systems for which Execution Cannot Be Performed

- When the machine system can move only in one direction
- When the range of motion is 0.5 rotations or less

#### Systems for Which Adjustments Cannot Be Made Accurately

- When a suitable range of motion is not possible
- When the moment of inertia changes within the set operating range
- When the machine has high dynamic friction
- When the rigidity of the machine is low and vibration occurs when positioning is performed
- When the position integration function is used
- When proportional control is used

- When mode switching is used

Note: If you specify moment of inertia estimation, mode switching will be disabled and PI control will be used while the moment of inertia is being calculated. Mode switching will be enabled after moment of inertia estimation has been completed.

- When speed feedforward or torque feedforward is input

## Preparations

Check the following settings before you execute moment of inertia estimation.

- The main circuit power supply must be ON.
- There must be no overtravel.
- The servo must be OFF.
- The control method must not be set to torque control.
- The first gains must be selected.
- The test without a motor function must be disabled (Pn00C = n.□□□0).
- There must be no alarms or warnings.
- There must be no hard wire base block (HWBB).
- The parameters must not be write prohibited.
- The tuning-less function must be disabled (Pn170 = n.□□□0).

## 9.5.3 Applicable Tools

The following table lists the tools that you can use to estimate the moment of inertia.

| Tool      | Fn No./Function Name   | Operating Procedure Reference  |
|-----------|------------------------|--|
| SigmaWin+ | <i>Tuning - Tuning</i> |  9.5.4 Operating Procedure on page 9-17 |

## 9.5.4 Operating Procedure

Use the following procedure to set the moment of inertia ratio.

### WARNING

- Estimating the moment of inertia requires operating the motor and therefore presents hazards. Observe the following precaution.
  - Confirm safety around moving parts.
 

This function involves automatic operation with vibration. Make sure that you can perform an emergency stop (to turn OFF the power supply) at any time. There will be movement in both directions within the set range of movement. Check the range of movement and the directions and implement protective controls for safety, such as the overtravel functions.

### CAUTION

- Be aware of the following points if you cancel the moment of inertia estimation while the motor is operating.
  - If you cancel operation with the **Servo OFF** Button, the motor will stop according to setting of the Servo OFF stopping method (Pn001 = n.□□□X).
  - If you cancel operation with the **Cancel** Button, the motor will decelerate to a stop and then enter a zero-clamped state.

1. Click the  Servo Drive Button in the workspace of the Main Window of the SigmaWin+.
2. Select **Tuning** in the Menu Dialog Box.  
The Tuning Dialog Box will be displayed.  
Click the **Cancel** Button to cancel tuning.
3. Click the **Execute** Button.

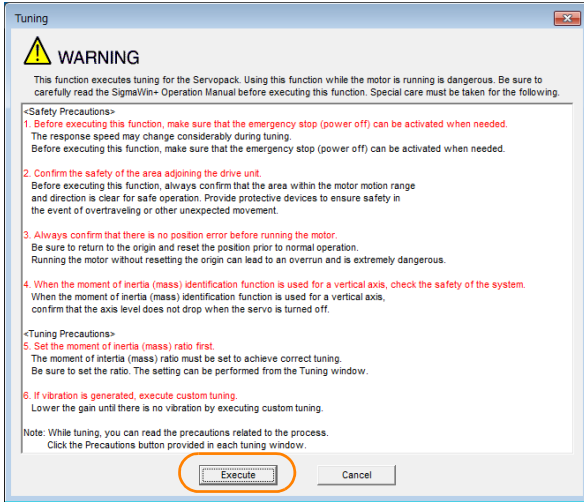

4. Click the **Execute** Button.

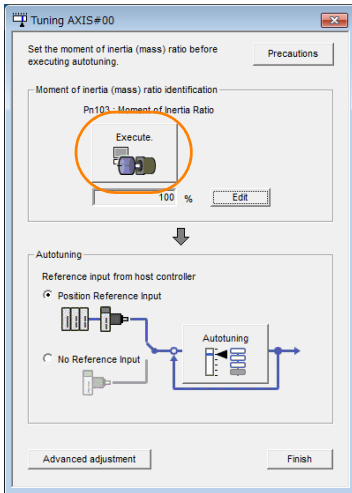

## 5. Set the conditions as required.

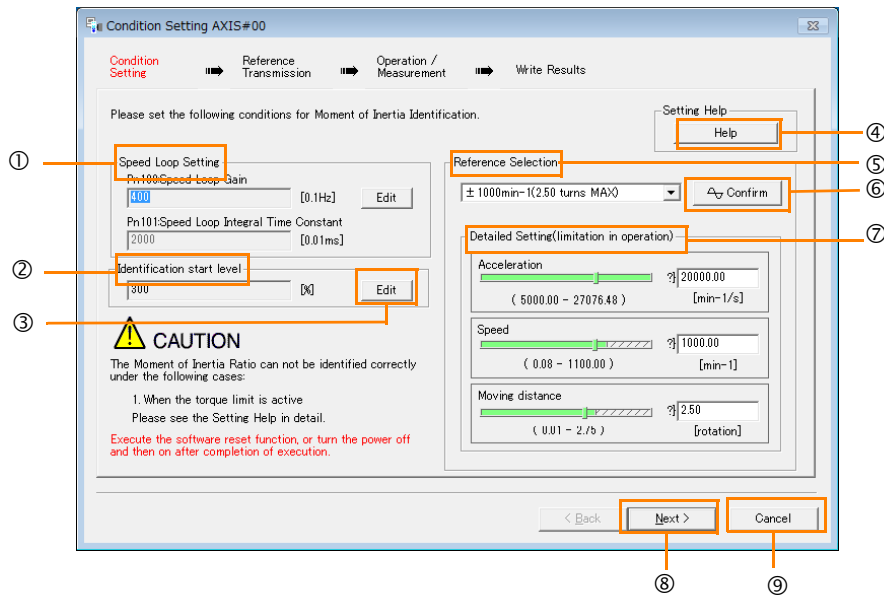
① **Speed Loop Setting Area**

Make the speed loop settings in this area.

If the speed loop response is too bad, it will not be possible to measure the moment of inertia ratio accurately.

The values for the speed loop response that are required for moment of inertia estimation are set for the default settings. It is normally not necessary to change these settings. If the default speed loop gain is too high for the machine (i.e., if vibration occurs), lower the setting. It is not necessary to increase the setting any farther.

② **Identification Start Level Group**

This is the setting of the moment of inertia calculation starting level.

If the load is large or the machine has low rigidity, the torque limit may be applied, causing moment of inertia estimation to fail.

If that occurs, estimation may be possible if you double the setting of the start level.

③ **Edit Buttons**

Click the button to display a dialog box to change the settings related to the speed loop or estimation start level.

④ **Help Button**

Click this button to display guidelines for setting the reference conditions. Make the following settings as required.

- Operate the motor to measure the load moment of inertia of the machine in comparison with the rotor moment of inertia.
- Set the operation mode, reference pattern (maximum acceleration rate, maximum speed, and maximum travel distance), and speed loop-related parameters.
- Correct measurement of the moment of inertia ratio may not be possible depending on the settings. Set suitable settings using the measurement results as reference.

⑤ **Reference Selection Area**

Either select the reference pattern for estimation processing from the box, or set the values in the **Detailed Setting** Group. Generally speaking, the larger the maximum acceleration rate is, the more accurate the moment of inertia estimation will be.

Set the maximum acceleration range within the possible range of movement considering the gear ratio, e.g., the pulley diameters or ball screw pitch.

⑥ **Confirm** Button

Click this button to display the Reference Confirmation Dialog Box.

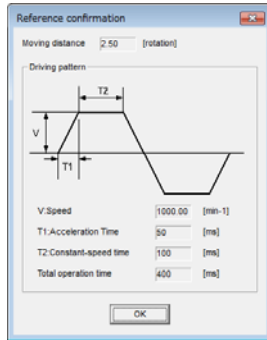

⑦ **Detailed Setting** Area

You can change the settings by moving the bars or directly inputting the settings to create the required reference pattern.

⑧ **Next** Button

Click this button to display the Reference Transmission Dialog Box.

⑨ **Cancel** Button

Click this button to return to the Tuning Dialog Box.

**CAUTION**

- The travel distance is the distance for one operation in the forward or reverse direction. During multiple operations, the operation starting position may move in one direction or the other. Confirm the possible operating range for each measurement or operation.
- Depending on the parameter settings and the moment of inertia of the machine, overshooting may occur and may cause the maximum speed setting to be exceeded temporarily. Allow sufficient leeway in the settings.

**Information** When Measurement Is Not Correct

Estimating the moment of inertia ratio cannot be performed correctly if the torque limit is activated. Adjust the limits or reduce the acceleration rate in the reference selection so that the torque limit is not activated.

6. Click the **Next** Button.

The Reference Transmission Dialog Box will be displayed.

7. Click the **Start** Button.

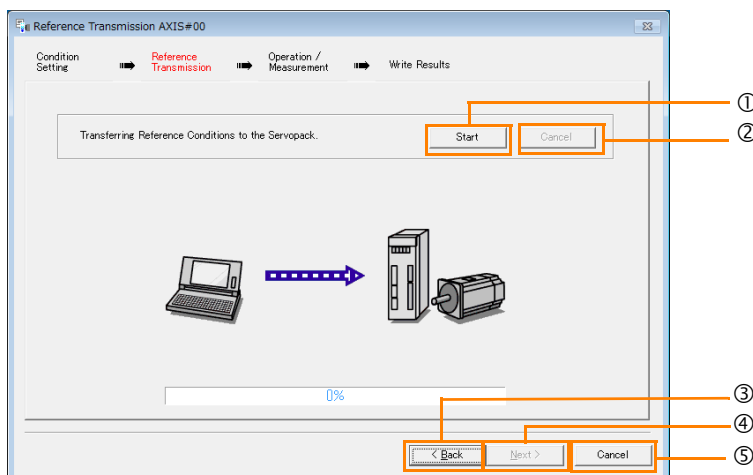

① **Start** Button

The reference conditions will be transferred to the SERVOPACK. A progress bar will show the progress of the transfer.

② **Cancel** Button

The **Cancel** Button is enabled only while data is being transferred to the SERVOPACK. You cannot use it after the transfer has been completed.

③ **Back** Button

This button returns you to the Condition Setting Dialog Box. It is disabled while data is being transferred.

④ **Next** Button

This button is enabled only when the data has been transferred correctly. You cannot use it if an error occurs or if you cancel the transfer before it is completed.

Click the **Next** Button to display the Operation/Masurement Dialog Box.

⑤ **Cancel** Button

This button cancels processing and returns you to the Tuning Dialog Box.

8. Click the **Next** Button.

The Operation/Masurement Dialog Box will be displayed.

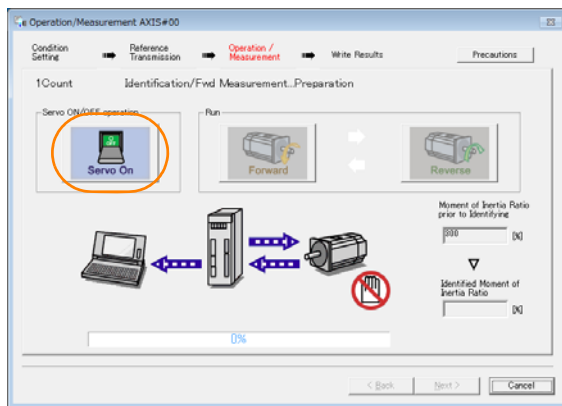
9. Click the **Servo On** Button.10. Click the **Forward** Button.

The shaft will rotate in the forward direction and the measurement will start. After the measurement and data transfer have been completed, the **Reverse** Button will be displayed in color.

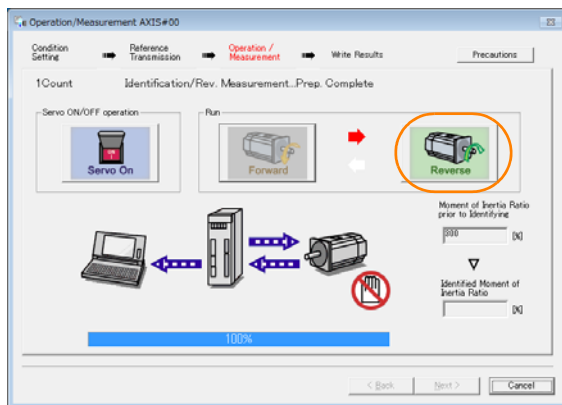
11. Click the **Reverse** Button.

The shaft will rotate in the reverse direction and the measurement will start. After the measurement and data transfer have been completed, the **Forward** Button will be displayed in color.

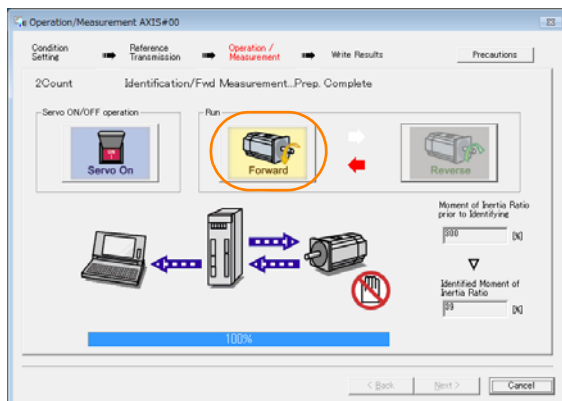

**12. Repeat steps 9 to 11 until the Next Button is enabled.**

Measurements are performed from 2 to 7 times and then verified. The number of measurements is displayed in upper left corner of the dialog box. A progress bar at the bottom of the dialog box will show the progress of the transfer each time.

**13. When the measurements have been completed, click the Servo On Button to turn OFF the servo.**

**14. Click the Next Button.**

The Write Results Dialog Box will be displayed.

**Information** If you click the **Next** Button before you turn OFF the servo, the following Dialog Box will be displayed. Click the **OK** Button to turn OFF the servo.

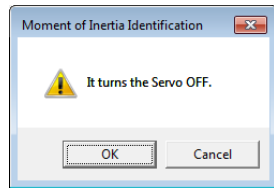

**15. Click the Writing Results Button.**

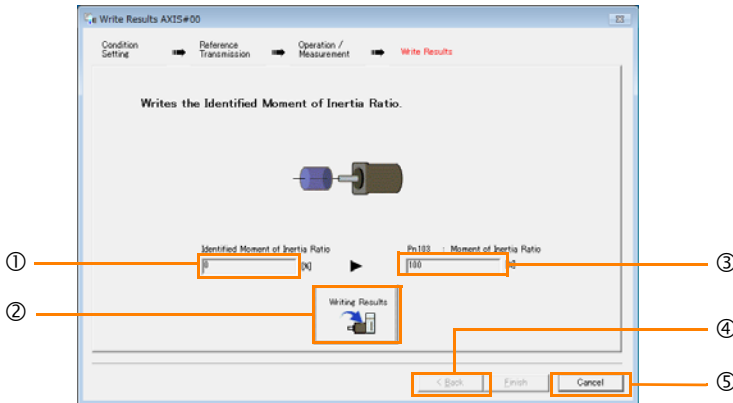

- ① **Identified Moment of Inertia Ratio** Box  
The moment of inertia ratio that was found with operation and measurements is displayed here.
- ② **Writing Results** Button  
If you click this button, Pn103 (Moment of Inertia Ratio) in the SERVOPACK is set to the value that is displayed for the identified moment of inertia ratio.
- ③ **Pn103: Moment of Inertia Ratio** Box  
The value that is set for the parameter is displayed here.  
After you click the **Writing Results** Button, the value that was found with operation and measurements will be displayed as the new setting.
- ④ **Back** Button  
This button is disabled.
- ⑤ **Cancel** Button  
This button will return you to the Tuning Dialog Box.

**16. Confirm that the Identified Moment of Inertia Ratio Box and the Pn103: Moment of Inertia Ratio Box show the same value and then click the Finish Button.**

**17. Click the OK Button.**

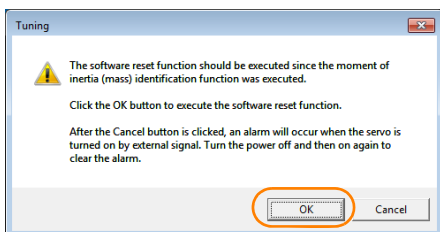

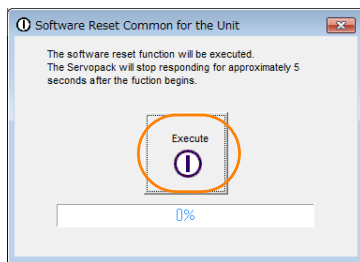

**18. Click the Execute Button.**

If the setting of the moment of inertia ratio (Pn103) was changed, the new value will be saved and the Tuning Dialog Box will be displayed again.

This concludes the procedure to estimate the moment of inertia ratio.

# 9.6 Autotuning without Host Reference

This section describes autotuning without a host reference.



Important

- Autotuning without a host reference performs adjustments based on the setting of the speed loop gain (Pn100). Therefore, precise adjustments cannot be made if there is vibration when adjustments are started. Make adjustments after lowering the speed loop gain (Pn100) until vibration is eliminated.
- You cannot execute autotuning without a host reference if the tuning-less function is enabled (Pn170 = n.□□□1 (default setting)). Disable the tuning-less function (Pn170 = n.□□□0) before you execute autotuning without a host reference.
- If you change the machine load conditions or drive system after you execute autotuning without a host reference and then you execute autotuning without a host reference with moment of inertia estimation specified, use the following parameter settings. If you execute autotuning without a host reference for any other conditions, the machine may vibrate and may be damaged.
  - Pn140 = n.□□□0 (Do not use model following control.)
  - Pn160 = n.□□□0 (Do not use anti-resonance control.)
  - Pn408 = n.00□0 (Disable friction compensation, first stage notch filter, and second stage notch filter.)

Note: If you are using the Digital Operator and the above parameters are not displayed, change the parameter display setting to display all parameters (Pn00B = n.□□□1) and then turn the power supply OFF and ON again.

## 9.6.1 Outline

For autotuning without a host reference, operation is automatically performed by the SERVO-PACK for round-trip (forward and reverse) operation to adjust for machine characteristics during operation. A reference from the host controller is not used.

The following items are adjusted automatically.

- Moment of inertia ratio
- Gains (e.g., speed loop gain and position loop gain)
- Filters (torque reference filter and notch filters)
- Friction compensation
- Anti-resonance control
- Vibration suppression (only for mode 2 or 3)

Refer to the following section for details on the parameters that are adjusted.

 9.6.7 Related Parameters on page 9-34

The motor is operated with the following specifications.

|                     |   |   |
|---------------------|---|---|
| Maximum Speed       | Rated motor speed × $\frac{2}{3}$   |   |
| Acceleration Torque | Rated motor torque: Approx. 100%<br>Note: The acceleration torque depends on the setting of the moment of inertia ratio (Pn103), and the influences of machine friction and external disturbance. |   |
| Travel Distance     | Rotary Servomotors  | You can set the desired travel distance. The default setting is for a value equivalent to 3 motor shaft rotations.  |
|                     | Linear Servomotors  | You can set the desired travel distance in increments of 1,000 reference units. (The default setting is for 90 mm.) |

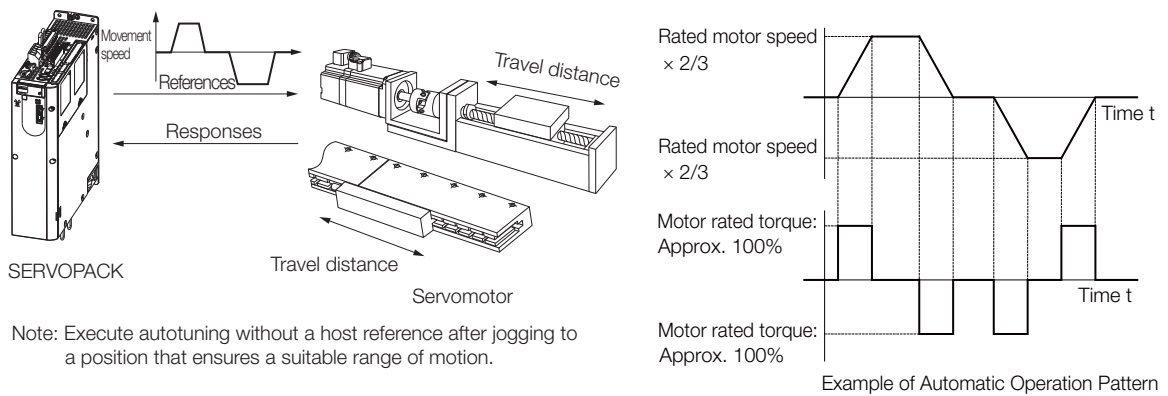

## ! WARNING

- Autotuning without a host reference requires operating the motor and therefore presents hazards. Observe the following precaution.
  - Confirm safety around moving parts.
    - This function involves automatic operation with vibration. Make sure that you can perform an emergency stop (to turn OFF the power supply) at any time. There will be movement in both directions within the set range of movement. Check the range of movement and the directions and implement protective controls for safety, such as the overtravel functions.

## 9.6.2 Restrictions

The following restrictions apply to autotuning without a host reference.

If you cannot use autotuning without a host reference because of these restrictions, use autotuning with a host reference or custom tuning. Refer to the following sections for details.

9.7 Autotuning with a Host Reference on page 9-35

9.8 Custom Tuning on page 9-42

### Systems for Which Execution Cannot Be Performed

- When the machine system can move only in one direction
- When the range of motion is 0.5 rotations or less

### Systems for Which Adjustments Cannot Be Made Accurately

- When a suitable range of motion is not possible
- When the moment of inertia changes within the set operating range
- When the machine has high friction
- When the rigidity of the machine is low and vibration occurs when positioning is performed
- When the position integration function is used
- When proportional control is used
- When mode switching is used

Note: If you specify moment of inertia estimation, mode switching will be disabled and PI control will be used while the moment of inertia is being calculated. Mode switching will be enabled after moment of inertia estimation has been completed.

- When speed feedforward or torque feedforward is input
- When the positioning completed width (Pn522) is too narrow

## Preparations



Check the following settings before you execute autotuning without a host reference.

- The main circuit power supply must be ON.
- There must be no overtravel.
- The servo must be OFF.
- The control method must not be set to torque control.
- The first gains must be selected.
- The test without a motor function must be disabled (Pn00C = n.□□□0).
- There must be no alarms or warnings.
- There must be no hard wire base block (HWBB).
- The parameters must not be write prohibited.
- The tuning-less function must be disabled (Pn170 = n.□□□0), or the tuning-less function must be enabled (Pn170 = n.□□□1) (default setting) and moment of inertia estimation must be specified.
- If you execute autotuning without a host reference during speed control, set the mode to 1.

**Information** • If you start autotuning without a host reference while the SERVOPACK is in speed control for mode 2 or 3, the SERVOPACK will change to position control automatically to perform autotuning without a host reference. The SERVOPACK will return to speed control after autotuning has been completed.

## 9.6.3 Applicable Tools

The following table lists the tools that you can use to perform autotuning without a host reference.

| Tool             | Fn No./Function Name   | Operating Procedure Reference  |
|------------------|------------------------|--|
| Digital Operator | Fn201                  |  Σ-7-Series Digital Operator Operating Manual (Manual No.: SIEP S800001 33) |
| SigmaWin+        | <i>Tuning - Tuning</i> |  9.6.4 Operating Procedure on page 9-26                                     |

## 9.6.4 Operating Procedure

Use the following procedure to perform autotuning without a host reference.

 **CAUTION**

- If you specify not estimating the moment of inertia, set the moment of inertia ratio (Pn103) correctly. If the setting greatly differs from the actual moment of inertia ratio, normal control of the machine may not be possible, and vibration may result.

1. Confirm that the moment of inertia ratio (Pn103) is set correctly.
2. Click the  Servo Drive Button in the workspace of the Main Window of the SigmaWin+.
3. Select **Tuning** in the Menu Dialog Box.  
The Tuning Dialog Box will be displayed.  
Click the **Cancel** Button to cancel tuning.

## 4. Click the Execute Button.

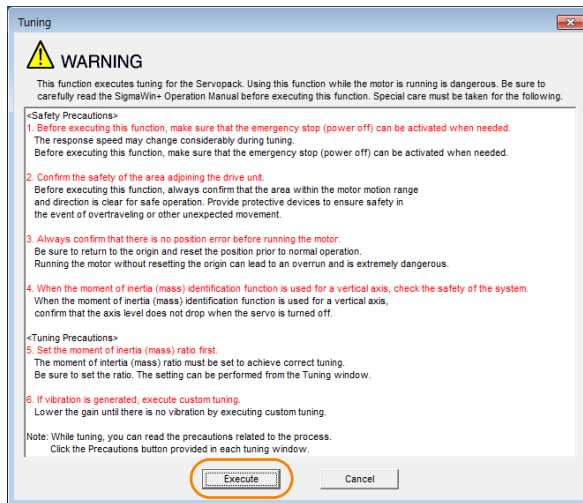

## 5. Select the No Reference Input Option in the Autotuning Area and then click the Autotuning Button.

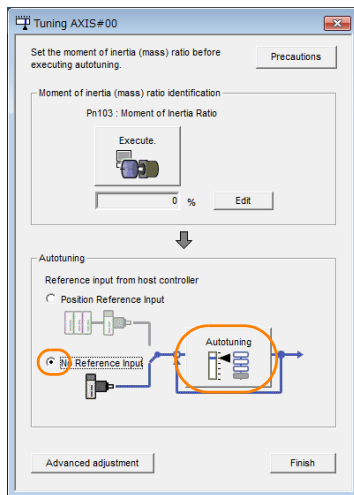

**Information** When the following dialog box is displayed, click the **OK** Button and then confirm that the correct moment of inertia ratio is set in Pn103 (Moment of Inertia Ratio).

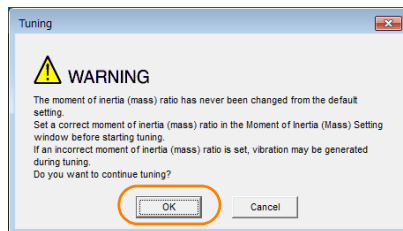

6. Set the conditions in the **Switching the load moment of inertia (load mass) identification Box**, the **Mode selection Box**, the **Mechanism selection Box**, and the **Distance Box**, and then click the **Next Button**.

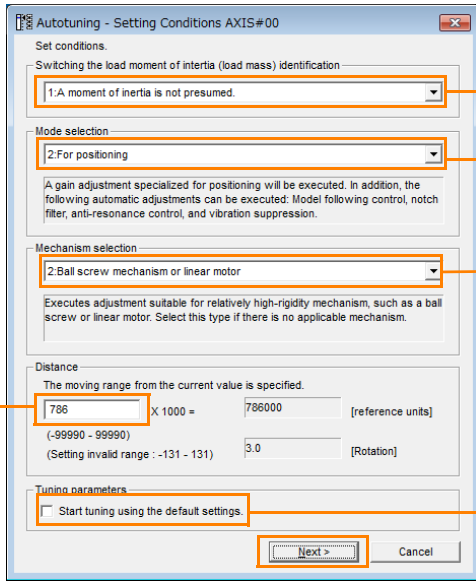

• **Switching the load moment of inertia (load mass) identification Box**  
 Specify whether to estimate the moment of inertia.  
 0: A moment of inertia is presumed. (default setting)  
 1: A moment of inertia is not presumed.

• **Mode selection Box**  
 Set the mode.

| Mode Selection  | Description  |
|---|--|
| 1: Standard   | Standard gain adjustment is performed. In addition to gain adjustment, notch filters and anti-resonance control are automatically adjusted.  |
| 2: For positioning                                    | Tuning is performed for positioning applications. In addition to gain adjustment, model following control, notch filters, anti-resonance control, and vibration suppression are automatically adjusted.                  |
| 3: For positioning especially to prevent overshooting | Tuning is performed for positioning applications with emphasis on eliminating overshooting. In addition to gain adjustment, notch filters, anti-resonance control, and vibration suppression are automatically adjusted. |

• **Distance Box**  
 Set the travel distance.  
 Movement range: -99,990,000 to +99,990,000 [reference units]  
 Minimum setting increment for travel distance: 1,000 [reference units]  
 Negative values are for reverse operation and positive values are for forward operation from the current position.  
 Default settings:  
 Rotary Servomotors: Approx. 3 rotations  
 Linear Servomotors: Approx 90 mm  
 Set the distance to the following values or higher. To ensure tuning precision, we recommend that you use approximately the default distance setting.  
 Rotary Servomotors: 0.5 rotations  
 Linear Servomotors: 5 mm

• **Mechanism selection Box**  
 Select the type according to the machine element to drive.  
 If there is noise or if the gain does not increase, better results may be obtained by changing the rigidity type. Select the type according to the following guidelines.

| Mechanism Selection                     | Description  |
|---|--|
| 1: Belt mechanism                       | Tuning is performed for a mechanism with relatively low rigidity, e.g., a belt.  |
| 2: Ball screw mechanism or linear motor | Tuning is performed for a mechanism with relatively high rigidity, e.g., a ball screw or Linear Servomotor. Use this setting if there is no other appropriate setting. |
| 3: Rigid model                          | Tuning is performed for a mechanism with high rigidity, e.g., a rigid body system.   |

• **Tuning parameters Box**  
 Specify the parameters to use for tuning.  
 If you select the **Start tuning using the default settings** Check Box, the tuning parameters will be returned to the default settings before tuning is started.

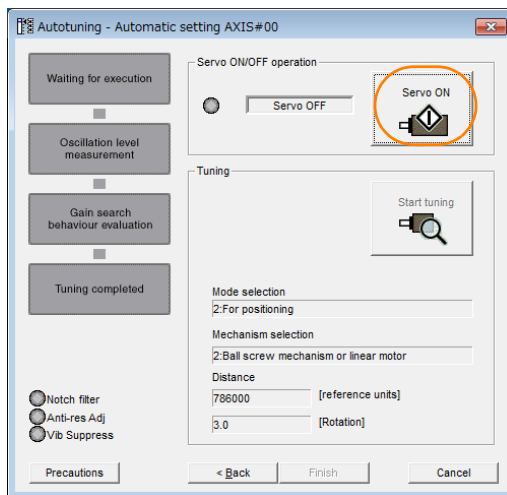
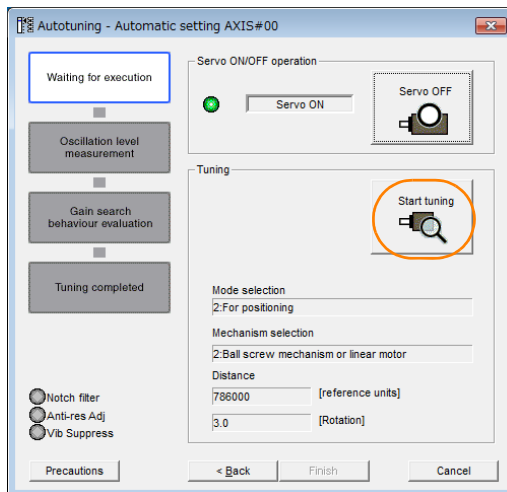
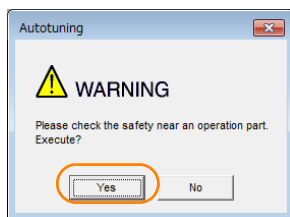
7. Click the **Servo ON** Button.8. Click the **Start tuning** Button.9. Confirm safety around moving parts and click the **Yes** Button.

The motor will start operating and tuning will be executed. Vibration that occurs during tuning will be detected automatically and suitable settings will be made for that vibration. When the settings have been completed, the indicators for the functions that were used will light at the lower left of the dialog box.



**10. When tuning has been completed, click the Finish Button.**

The results of tuning will be set in the parameters and you will return to the Tuning Dialog Box.

This concludes the procedure to perform autotuning without a host reference.

## 9.6.5 Troubleshooting Problems in Autotuning without a Host Reference

The following tables give the causes of and corrections for problems that may occur in autotuning without a host reference.

◆ **Autotuning without a Host Reference Was Not Performed**

| Possible Cause   | Corrective Action  |
|--|--|
| Main circuit power supply is OFF.                          | Turn ON the main circuit power supply.   |
| An alarm or warning occurred.                              | Remove the cause of the alarm or warning.  |
| Overtraveling occurred.                                    | Remove the cause of overtraveling.   |
| The second gains were selected with the gain selection.    | Disable automatic gain switching.  |
| The HWBB was activated.                                    | Release the HWBB.  |
| The setting of the travel distance is too small.           | Set the travel distance again in step 6 of the procedure.  |
| The settings for the tuning-less function are not correct. | <ul style="list-style-type: none"> <li>• Disable the tuning-less function (Pn170 = n.□□□0).</li> <li>• Enable the tuning-less function (Pn170 = n.□□□1) and specify moment of inertia estimation.</li> </ul> |



### ◆ When an Error Occurs during Execution of Autotuning without a Host Reference

| Error  | Possible Cause  | Corrective Action  |
|--|---|--|
| The gain adjustments were not successfully completed.  | Machine vibration occurs or the positioning completion signal is not stable when the Servomotor stops.  | <ul style="list-style-type: none"> <li>• Increase the setting of the positioning completed width (Pn522).</li> <li>• Change the mode from 2 to 3.</li> <li>• If machine vibration occurs, suppress the vibration with the anti-resonance control adjustment and the vibration suppression function.</li> </ul> |
| An error occurred during calculation of the moment of inertia.   | Refer to the following section for troubleshooting information.<br> ◆ <i>When an Error Occurs during Calculation of Moment of Inertia on page 9-31</i> |  |
| Positioning was not completed within approximately 10 seconds after position adjustment was completed. | The positioning completed width is too narrow or proportional control is being used.  | Increase the setting of the positioning completed width (Pn522).   |

### ◆ When an Error Occurs during Calculation of Moment of Inertia

| Possible Cause   | Corrective Action  |
|--|--|
| The SERVOPACK started calculating the moment of inertia but the calculation was not completed. | <ul style="list-style-type: none"> <li>• Increase the setting of the speed loop gain (Pn100).</li> <li>• Increase the stroke (travel distance).</li> </ul>   |
| The moment of inertia fluctuated greatly and did not converge within 10 tries.                 | Set Pn103 (Moment of Inertia Ratio) from the machine specifications and specify not estimating the moment of inertia.  |
| Low-frequency vibration was detected.  | Double the setting of moment of inertia calculation starting level (Pn324).  |
| The torque limit was reached.  | <ul style="list-style-type: none"> <li>• If you are using the torque limit, increase the torque limit.</li> <li>• Double the setting of moment of inertia calculation starting level (Pn324).</li> </ul> |
| Speed control changed to proportional control during calculation of the moment of inertia.     | Use PI control when calculating the moment of inertia.   |

### ◆ Adjustment Results Are Not Satisfactory for Position Control

You may be able to improve the adjustment results by changing the settings of the positioning completed width (Pn522) and position reference unit (*position user unit* (2701h)).

If satisfactory results are still not possible, adjust the overshoot detection level (Pn561). That may improve the adjustment results.

- Pn561 = 100% (default setting)  
This will allow tuning with overshooting that is equivalent to the positioning completed width.
- Pn561 = 0%  
This will allow tuning to be performed without overshooting within the positioning completed width, but the positioning completed width may be extended.

| Pn561<br>(2561h) | Overshoot Detection Level |              |                 | Speed        | Position       | Torque |
|------------------|---------------------------|--------------|-----------------|--------------|----------------|--------|
|                  | Setting Range             | Setting Unit | Default Setting | When Enabled | Classification |        |
|                  | 0 to 100                  | 1%           | 100             | Immediately  | Setup          |        |

## 9.6.6 Automatically Adjusted Function Settings

You can specify whether to automatically adjust the following functions during autotuning.

### ◆ Automatic Notch Filters

Normally, set Pn460 to n.□1□□ (Adjust automatically) (default setting).

Vibration will be detected during autotuning without a host reference and a notch filter will be adjusted.

Set Pn460 to n.□0□□ (Do not adjust automatically) only if you do not change the setting of the notch filter before you execute this function.

| Parameter        |                             | Function  | When Enabled | Classification |
|------------------|-----------------------------|---|--------------|----------------|
| Pn460<br>(2460h) | n.□□□0                      | Do not adjust the first stage notch filter automatically during execution of autotuning without a host reference, autotuning with a host reference, and custom tuning.  | Immediately  | Tuning         |
|                  | n.□□□1<br>(default setting) | Adjust the first stage notch filter automatically during execution of autotuning without a host reference, autotuning with a host reference, and custom tuning.         |              |                |
|                  | n.□0□□                      | Do not adjust the second stage notch filter automatically during execution of autotuning without a host reference, autotuning with a host reference, and custom tuning. |              |                |
|                  | n.□1□□<br>(default setting) | Adjust the second stage notch filter automatically during execution of autotuning without a host reference, autotuning with a host reference, and custom tuning.        |              |                |

### ◆ Anti-Resonance Control Adjustment

This function reduces low vibration frequencies, for which the notch filters cannot be used.

Normally, set Pn160 to n.□□1□ (Adjust automatically) (default setting).

Vibration will be detected during autotuning without a host reference and anti-resonance control will be automatically adjusted.

| Parameter        |                             | Function   | When Enabled | Classification |
|------------------|-----------------------------|--|--------------|----------------|
| Pn160<br>(2160h) | n.□□0□                      | Do not adjust anti-resonance control automatically during execution of autotuning without a host reference, autotuning with a host reference, and custom tuning. | Immediately  | Tuning         |
|                  | n.□□1□<br>(default setting) | Adjust anti-resonance control automatically during execution of autotuning without a host reference, autotuning with a host reference, and custom tuning.        |              |                |

### ◆ Vibration Suppression

You can use vibration suppression to suppress transitional vibration at a low frequency from 1 Hz to 100 Hz, which is generated mainly when the machine vibrates during positioning.

Normally, set Pn140 to n.□1□□ (Adjust automatically) (default setting).

Vibration will be detected during autotuning without a host reference and vibration suppression control will be automatically set.

Set Pn140 = n.□0□□ (Do not adjust automatically) only if you do not change the settings for vibration suppression before you execute autotuning without a host reference.

Note: Autotuning without a host reference uses model following control. Therefore, it can be executed only if the mode is set to 2 or 3.

| Parameter        |                             | Function  | When Enabled | Classification |
|------------------|-----------------------------|---|--------------|----------------|
| Pn140<br>(2140h) | n.0□□□                      | Do not adjust vibration suppression automatically during execution of autotuning without a host reference, autotuning with a host reference, and custom tuning. | Immediately  | Tuning         |
|                  | n.1□□□<br>(default setting) | Adjust vibration suppression automatically during execution of autotuning without a host reference, autotuning with a host reference, and custom tuning.        |              |                |

### ◆ Friction Compensation

Friction compensation compensates for changes in the following conditions.

- Changes in the viscous resistance of the lubricant, such as grease, on the sliding parts of the machine
- Changes in the friction resistance resulting from variations in the machine assembly
- Changes in the friction resistance due to aging

The conditions for applying friction compensation depend on the mode selection.

| Mode Selection Settings                            | Friction Compensation   |
|--|---|
| 1: Standard  | Based on the setting of Pn408 = n.X□□□<br>(Friction Compensation Function Selection)* |
| 2: For position control                            | Adjusted with friction compensation.  |
| 3: For position control (emphasis on overshooting) |   |

\* Refer to the following section for details.

 Required Parameter Settings on page 9-68

| Parameter        |                             | Function                       | When Enabled | Classification |
|------------------|-----------------------------|--------------------------------|--------------|----------------|
| Pn408<br>(2408h) | n.0□□□<br>(default setting) | Disable friction compensation. | Immediately  | Setup          |
|                  | n.1□□□                      | Enable friction compensation.  |              |                |

### ◆ Feedforward

If Pn140 is set to n.0□□□ (Do not use model following control and speed/torque feedforward together (default setting)) and tuning is performed with the mode selection set to 2 or 3, feedforward (Pn109), the speed feedforward input (VFF), and the torque feedforward input (TFF) will be disabled.

To use the speed feedforward input (VFF), the torque feedforward input (TFF), and model following control from the host controller in the system, set Pn140 to n.1□□□ (Use model following control and speed/torque feedforward together).

| Parameter        |                             | Function  | When Enabled | Classification |
|------------------|-----------------------------|---|--------------|----------------|
| Pn140<br>(2140h) | n.0□□□<br>(default setting) | Do not use model following control and speed/torque feedforward together. | Immediately  | Tuning         |
|                  | n.1□□□                      | Use model following control and speed/torque feedforward together.        |              |                |



Important

When model following control is used with the feedforward function, it is used to make optimum feedforward settings in the SERVOPACK. Therefore, model following control is not normally used together with either the speed feedforward input (VFF) or torque feedforward input (TFF) from the host controller. However, model following control can be used with the speed feedforward input (VFF) or torque feedforward input (TFF) if required. An unsuitable feedforward input may result in overshooting.

## 9.6.7 Related Parameters

The following parameters are automatically adjusted or used as reference when you execute autotuning without a host reference.

Do not change the settings while autotuning without a host reference is being executed.

| Parameter     | Name  | Automatic Changes |
|---------------|---|-------------------|
| Pn100 (2100h) | Speed Loop Gain   | Yes               |
| Pn101 (2101h) | Speed Loop Integral Time Constant                       | Yes               |
| Pn102 (2102h) | Position Loop Gain                                      | Yes               |
| Pn103 (2103h) | Moment of Inertia Ratio                                 | Yes               |
| Pn121 (2121h) | Friction Compensation Gain                              | Yes               |
| Pn123 (2123h) | Friction Compensation Coefficient                       | Yes               |
| Pn124 (2124h) | Friction Compensation Frequency Correction              | No                |
| Pn125 (2125h) | Friction Compensation Gain Correction                   | Yes               |
| Pn401 (2401h) | First Stage First Torque Reference Filter Time Constant | Yes               |
| Pn408 (2408h) | Torque-Related Function Selections                      | Yes               |
| Pn409 (2409h) | First Stage Notch Filter Frequency                      | Yes               |
| Pn40A (240Ah) | First Stage Notch Filter Q Value                        | Yes               |
| Pn40C (240Ch) | Second Stage Notch Filter Frequency                     | Yes               |
| Pn40D (240Dh) | Second Stage Notch Filter Q Value                       | Yes               |
| Pn140 (2140h) | Model Following Control-Related Selections              | Yes               |
| Pn141 (2141h) | Model Following Control Gain                            | Yes               |
| Pn142 (2142h) | Model Following Control Gain Correction                 | Yes               |
| Pn143 (2143h) | Model Following Control Bias in the Forward Direction   | Yes               |
| Pn144 (2144h) | Model Following Control Bias in the Reverse Direction   | Yes               |
| Pn145 (2145h) | Vibration Suppression 1 Frequency A                     | Yes               |
| Pn146 (2146h) | Vibration Suppression 1 Frequency B                     | Yes               |
| Pn147 (2147h) | Model Following Control Speed Feedforward Compensation  | Yes               |
| Pn160 (2160h) | Anti-Resonance Control-Related Selections               | Yes               |
| Pn161 (2161h) | Anti-Resonance Frequency                                | Yes               |
| Pn163 (2163h) | Anti-Resonance Damping Gain                             | Yes               |
| Pn531 (2531h) | Program Jogging Travel Distance                         | No                |
| Pn533 (2533h) | Program Jogging Movement Speed for Rotary Servomotor    | No                |
| Pn585 (2585h) | Program Jogging Movement Speed for Linear Servomotor    | No                |
| Pn534 (2534h) | Program Jogging Acceleration/Deceleration Time          | No                |
| Pn535 (2535h) | Program Jogging Waiting Time                            | No                |
| Pn536 (2536h) | Program Jogging Number of Movements                     | No                |

Yes: The parameter is automatically set.

No: The parameter is not automatically set, but the setting is read during execution.

## 9.7

## Autotuning with a Host Reference

This section describes autotuning with a host reference.



Autotuning with a host reference makes adjustments based on the set speed loop gain (Pn100). Therefore, precise adjustments cannot be made if there is vibration when adjustments are started. Make adjustments after lowering the speed loop gain (Pn100) until vibration is eliminated.

## 9.7.1

## Outline

Autotuning with a host reference automatically makes optimum adjustments for operation references from the host controller.

The following items are adjusted automatically.

- Gains (e.g., speed loop gain and position loop gain)
- Filters (torque reference filter and notch filters)
- Friction compensation
- Anti-resonance control
- Vibration suppression

Refer to the following section for details on the parameters that are adjusted.

9.7.7 Related Parameters on page 9-41

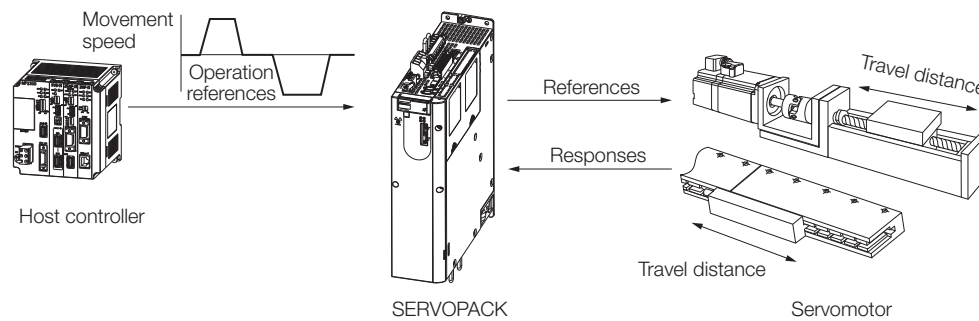
**CAUTION**

- Because autotuning with a host reference adjusts the SERVOPACK during automatic operation, vibration or overshooting may occur. To ensure safety, make sure that you can perform an emergency stop at any time.

## 9.7.2 Restrictions

### Systems for Which Adjustments Cannot Be Made Accurately

Adjustments will not be made correctly for autotuning with a host reference in the following cases. Use custom tuning.

- When the travel distance for the reference from the host controller is equal to or lower than the setting of the positioning completed width (Pn522)
- Rotary Servomotors: When the movement speed for the reference from the host controller is equal to or lower than the setting of the rotation detection level (Pn502)
- Linear Servomotors: When the movement speed for the reference from the host controller is equal to or lower than the setting of the zero speed level (Pn581)
- When the time required to stop is 10 ms or less
- When the rigidity of the machine is low and vibration occurs when positioning is performed
- When the position integration function is used
- When proportional control is used
- When mode switching is used
- When the positioning completed width (Pn522) is too narrow

Refer to the following sections for details on custom tuning.

 9.8 Custom Tuning on page 9-42



### Preparations

Check the following settings before you execute autotuning with a host reference.

- The servo must be in ready status.
- There must be no overtravel.
- The servo must be OFF.
- Position control must be selected if power is supplied to the motor (i.e., when the servo is ON).
- The first gains must be selected.
- The test without a motor function must be disabled (Pn00C = n.□□□0).
- There must be no warnings.
- The tuning-less function must be disabled (Pn170 = n.□□□0).
- The parameters must not be write prohibited.

## 9.7.3 Applicable Tools

The following table lists the tools that you can use to perform autotuning with a host reference.

| Tool             | Fn No./Function Name   | Operating Procedure Reference  |
|------------------|------------------------|--|
| Digital Operator | Fn202                  |  Σ-7-Series Digital Operator Operating Manual (Manual No.: SIEP S800001 33) |
| SigmaWin+        | <i>Tuning - Tuning</i> |  9.7.4 Operating Procedure on page 9-37                                     |

## 9.7.4 Operating Procedure

Use the following procedure to perform autotuning with a host reference.

1. Confirm that the moment of inertia ratio (Pn103) is set correctly.
2. Click the  Servo Drive Button in the workspace of the Main Window of the SigmaWin+.
3. Select **Tuning** in the Menu Dialog Box.  
The Tuning Dialog Box will be displayed.  
Click the **Cancel** Button to cancel tuning.
4. Click the **Execute** Button.

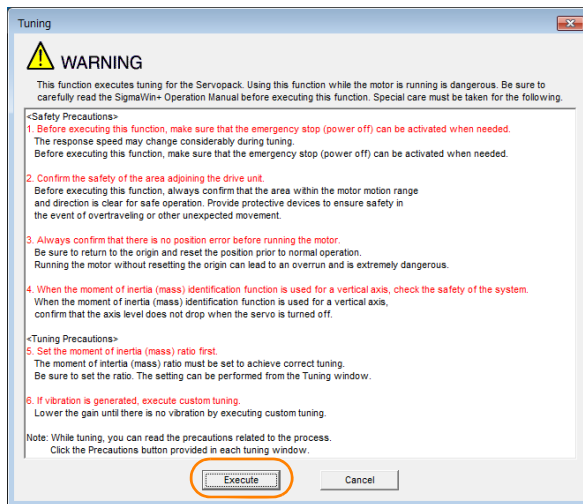

5. Select the **Position reference input** Option in the Autotuning Area and then click the **Autotuning** Button.

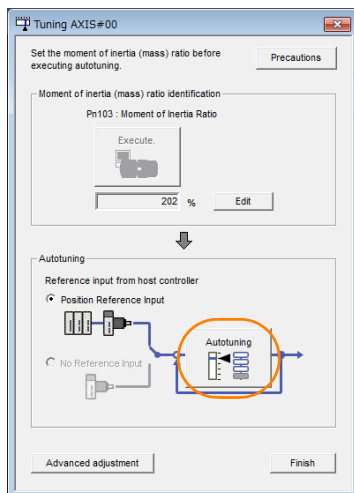

### Information

When the following dialog box is displayed, click the **OK** Button and then confirm that the correct moment of inertia ratio is set in Pn103 (Moment of Inertia Ratio).

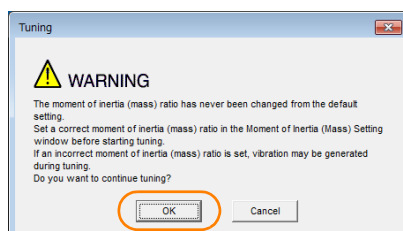

**6. Set the conditions in the Mode selection Box and the Mechanism selection Box, and then click the Next Button.**

If you select the **Start tuning using the default settings** Check Box in the **Tuning parameters** Area, the tuning parameters will be returned to the default settings before tuning is started.

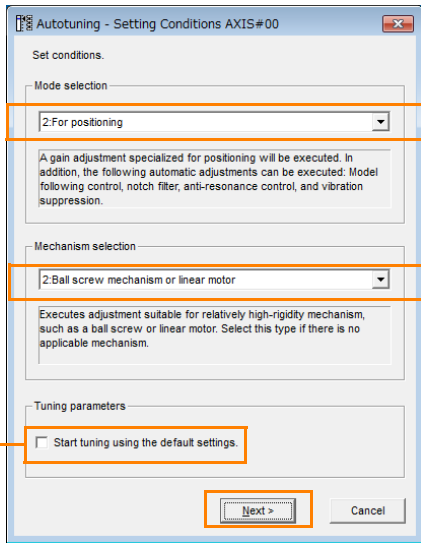

• **Mode selection Box**  
Set the mode.

| Mode Selection  | Description  |
|---|--|
| 1: Standard   | Standard gain adjustment is performed. In addition to gain adjustment, notch filters and anti-resonance control are automatically adjusted.  |
| 2: For positioning                                    | Tuning is performed for positioning applications. In addition to gain adjustment, model following control, notch filters, anti-resonance control, and vibration suppression are automatically adjusted.                  |
| 3: For positioning especially to prevent overshooting | Tuning is performed for positioning applications with emphasis on eliminating overshooting. In addition to gain adjustment, notch filters, anti-resonance control, and vibration suppression are automatically adjusted. |

• **Tuning parameters Box**  
Specify the parameters to use for tuning. If you select the **Start tuning using the default settings** Check Box, the tuning parameters will be returned to the default settings before tuning is started.

• **Mechanism selection Box**  
Select the type according to the machine element to drive. If there is noise or if the gain does not increase, better results may be obtained by changing the rigidity type. Select the type according to the following guidelines.

| Mechanism Selection                     | Description  |
|---|--|
| 1: Belt mechanism                       | Tuning is performed for a mechanism with relatively low rigidity, e.g., a belt.  |
| 2: Ball screw mechanism or linear motor | Tuning is performed for a mechanism with relatively high rigidity, e.g., a ball screw or Linear Servomotor. Use this setting if there is no other appropriate setting. |
| 3: Rigid model                          | Tuning is performed for a mechanism with high rigidity, e.g., a rigid body system.   |

**7. Click the Yes Button.**

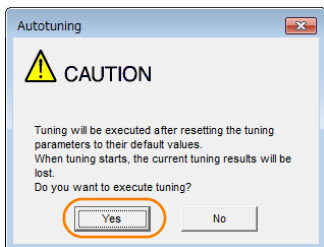



8. Input the correct moment of inertia ratio and click the Next Button.

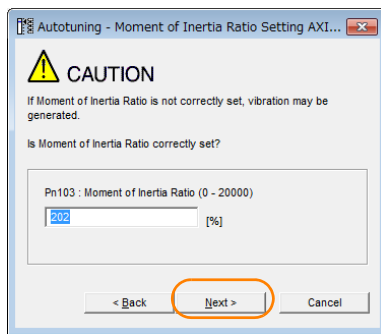

9. First confirm safety around moving parts. Then turn ON the servo, enter a reference from the host controller, and click the Start tuning Button.

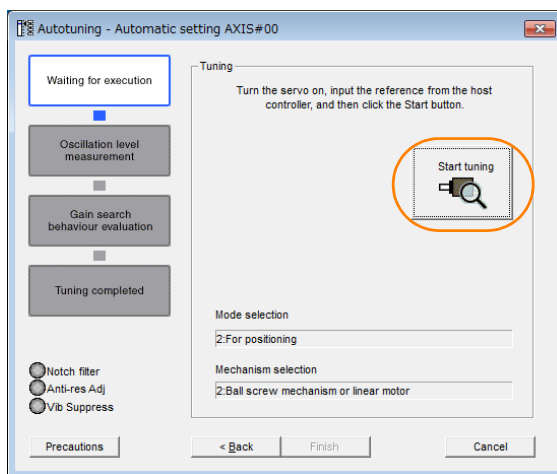

10. Click the Yes Button.

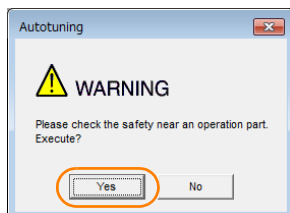

Tuning will be executed.

Vibration that occurs during tuning will be detected automatically and suitable settings will be made for that vibration. When the settings have been completed, the indicators for the functions that were used will light at the lower left of the dialog box.

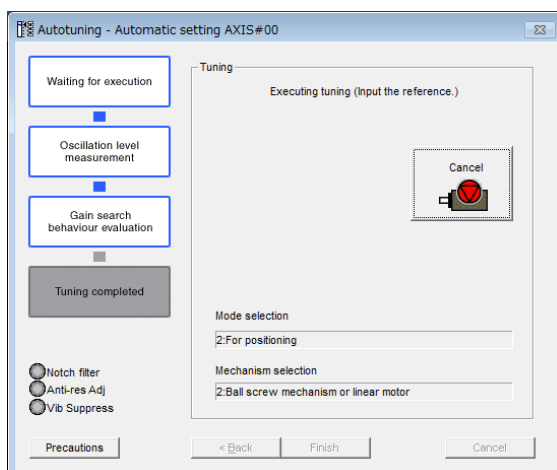

**11. When tuning has been completed, click the Finish Button.**

The results of tuning will be set in the parameters and you will return to the Tuning Dialog Box.

This concludes the procedure to perform autotuning with a host reference.

## 9.7.5 Troubleshooting Problems in Autotuning with a Host Reference

The following tables give the causes of and corrections for problems that may occur in autotuning with a host reference.

### ◆ Autotuning with a Host Reference Was Not Performed

| Possible Cause  | Corrective Action                         |
|---|---|
| Main circuit power supply is OFF.                       | Turn ON the main circuit power supply.    |
| An alarm or warning occurred.                           | Remove the cause of the alarm or warning. |
| Overtraveling occurred.                                 | Remove the cause of overtraveling.        |
| The second gains were selected with the gain selection. | Disable automatic gain switching.         |
| The HWBB was activated.                                 | Release the HWBB.                         |

### ◆ Troubleshooting Errors

| Error  | Possible Cause  | Corrective Action  |
|--|---|--|
| The gain adjustments were not successfully completed.  | Machine vibration occurs or positioning completion is not stable when the Servomotor stops. | <ul style="list-style-type: none"> <li>• Increase the setting of Pn522 (2522h) (Positioning Completed Width).</li> <li>• Change the mode from 2 to 3.</li> <li>• If machine vibration occurs, suppress the vibration with the anti-resonance control adjustment and the vibration suppression function.</li> </ul> |
| Positioning was not completed within approximately 10 seconds after position adjustment was completed. | The positioning completed width is too narrow or proportional control is being used.        | Increase the setting of Pn522 (2522h) (Positioning Completed Width).   |

### ◆ Adjustment Results Are Not Satisfactory for Position Control

You may be able to improve the adjustment results by changing the settings of the positioning completed width (Pn522) and position reference unit (*position user unit* (2701h)).

If satisfactory results are still not possible, adjust the overshoot detection level (Pn561). That may improve the adjustment results.

- Pn561 = 100% (default setting)  
This will allow tuning with overshooting that is equivalent to the positioning completed width.
- Pn561 = 0%  
This will allow tuning to be performed without overshooting within the positioning completed width, but the positioning completed width may be extended.

| Pn561<br>(2561h) | Overshoot Detection Level |              |                 | Speed        | Position       | Torque |
|------------------|---------------------------|--------------|-----------------|--------------|----------------|--------|
|                  | Setting Range             | Setting Unit | Default Setting | When Enabled | Classification |        |
|                  | 0 to 100                  | 1%           | 100             | Immediately  | Setup          |        |

## 9.7.6 Automatically Adjusted Function Settings

These function settings are the same as for autotuning without a host reference. Refer to the following section.

 9.6.6 Automatically Adjusted Function Settings on page 9-32

## 9.7.7 Related Parameters

The following parameters are automatically adjusted or used as reference when you execute autotuning with a host reference.

Do not change the settings while autotuning with a host reference is being executed.

| Parameter     | Name  | Automatic Changes |
|---------------|---|-------------------|
| Pn100 (2100h) | Speed Loop Gain   | Yes               |
| Pn101 (2101h) | Speed Loop Integral Time Constant                       | Yes               |
| Pn102 (2102h) | Position Loop Gain                                      | Yes               |
| Pn103 (2103h) | Moment of Inertia Ratio                                 | No                |
| Pn121 (2121h) | Friction Compensation Gain                              | Yes               |
| Pn123 (2123h) | Friction Compensation Coefficient                       | Yes               |
| Pn124 (2124h) | Friction Compensation Frequency Correction              | No                |
| Pn125 (2125h) | Friction Compensation Gain Correction                   | Yes               |
| Pn401 (2401h) | First Stage First Torque Reference Filter Time Constant | Yes               |
| Pn408 (2408h) | Torque-Related Function Selections                      | Yes               |
| Pn409 (2409h) | First Stage Notch Filter Frequency                      | Yes               |
| Pn40A (240Ah) | First Stage Notch Filter Q Value                        | Yes               |
| Pn40C (240Ch) | Second Stage Notch Filter Frequency                     | Yes               |
| Pn40D (240Dh) | Second Stage Notch Filter Q Value                       | Yes               |
| Pn140 (2140h) | Model Following Control-Related Selections              | Yes               |
| Pn141 (2141h) | Model Following Control Gain                            | Yes               |
| Pn142 (2142h) | Model Following Control Gain Correction                 | Yes               |
| Pn143 (2143h) | Model Following Control Bias in the Forward Direction   | Yes               |
| Pn144 (2144h) | Model Following Control Bias in the Reverse Direction   | Yes               |
| Pn145 (2145h) | Vibration Suppression 1 Frequency A                     | Yes               |
| Pn146 (2146h) | Vibration Suppression 1 Frequency B                     | Yes               |
| Pn147 (2147h) | Model Following Control Speed Feedforward Compensation  | Yes               |
| Pn160 (2160h) | Anti-Resonance Control-Related Selections               | Yes               |
| Pn161 (2161h) | Anti-Resonance Frequency                                | Yes               |
| Pn163 (2163h) | Anti-Resonance Damping Gain                             | Yes               |

Yes: The parameter is automatically set.

No: The parameter is not automatically set, but the setting is read during execution.

## 9.8 Custom Tuning

This section describes custom tuning.

### 9.8.1 Outline

You can use custom tuning to manually adjust the servo during operation using a speed or position reference input from the host controller. You can use it to fine-tune adjustments that were made with autotuning.

The following items are adjusted automatically.

- Gains (e.g., speed loop gain and position loop gain)
- Filters (torque reference filter and notch filters)
- Friction compensation
- Anti-resonance control

Refer to the following section for details on the parameters that are adjusted.

 [9.8.7 Related Parameters on page 9-49](#)

There are two adjustment methods that you can use for custom tuning.

■ **Tuning Mode 0 (Setting Servo Gains Giving Priority to Stability) or 1 (Setting Servo Gains Giving Priority to Good Response)**

These modes allow you to set stable control conditions for multiple servo gains by manipulating only one tuning level. Automatic setting of notch filters and anti-resonance control is provided if vibration is detected. Manual anti-resonance control adjustment is also possible during custom tuning.

■ **Tuning Mode 2 (Setting Servo Gains Giving Priority to Position Control Applications) or 3 (Setting Servo Gains Giving Priority to Preventing Overshooting in Position Control Applications)**

Two tuning levels are manipulated to reduce positioning time even further and set multiple servo gains.

Model following control is used to reduce the positioning time. If vibration is detected, notch filters and anti-resonance control are automatically adjusted, and friction compensation is automatically set. Manual anti-resonance control adjustment and vibration suppression are also possible during custom tuning.



### CAUTION

- Vibration or overshooting may occur during custom tuning. To ensure safety, make sure that you can perform an emergency stop at any time.



### 9.8.2 Preparations

Check the following settings before you execute custom tuning.

- The test without a motor function must be disabled (Pn00C = n.□□□0).
- The tuning-less function must be disabled (Pn170 = n.□□□0).
- If speed control is used, tuning mode 0 or 1 must be set.
- The parameters must not be write prohibited.

## 9.8.3 Applicable Tools

The following table lists the tools that you can use to perform custom tuning.

| Tool             | Fn No./Function Name   | Operating Procedure Reference   |
|------------------|------------------------|---|
| Digital Operator | Fn203                  |  $\Sigma$ -7-Series Digital Operator Operating Manual (Manual No.: SIEP S800001 33) |
| SigmaWin+        | <i>Tuning – Tuning</i> |  9.8.4 Operating Procedure on page 9-43   |

## 9.8.4 Operating Procedure

Use the following procedure to perform custom tuning.

### WARNING

- Before you execute custom tuning, check the information provided in the SigmaWin+ operating manual.  
Observe the following precautions.
  - Make sure that you can perform an emergency stop at any time.  
When custom tuning is started, several parameters will be overwritten with the recommended settings, which may greatly affect the response before and after execution. Make sure that you can perform an emergency stop at any time.
  - Set the moment of inertia correctly before you execute custom tuning.  
If the setting greatly differs from the actual moment of inertia, vibration may occur.
  - If you change the feedforward level, the new setting will not be used immediately. It will be used after positioning is completed.

1. Confirm that the moment of inertia ratio (Pn103) is set correctly.
2. Click the  Servo Drive Button in the workspace of the Main Window of the SigmaWin+.
3. Select **Tuning** in the Menu Dialog Box.  
The Tuning Dialog Box will be displayed.  
Click the **Cancel** Button to cancel tuning.
4. Click the **Execute** Button.

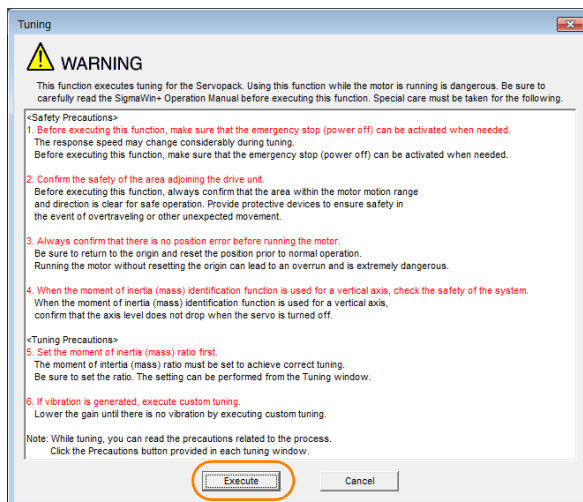

5. Click the **Advanced adjustment** Button.

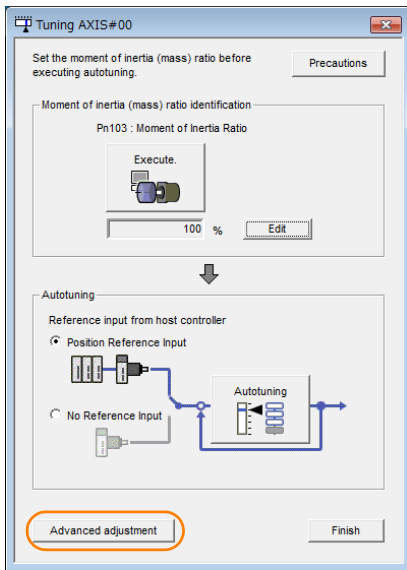

**Information** When the following dialog box is displayed, click the **OK** Button and then confirm that the correct moment of inertia ratio is set in Pn103 (Moment of Inertia Ratio).

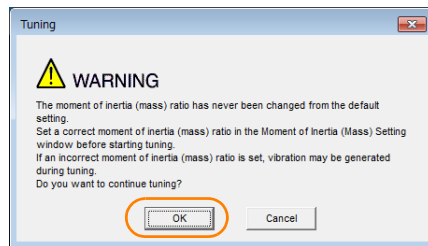

6. Click the **Custom tuning** Button.

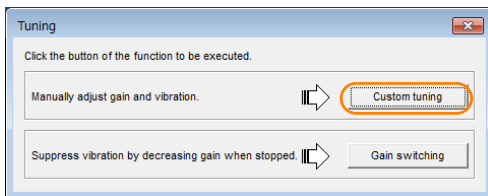

- Set the Tuning mode Box and Mechanism selection Box, and then click the Next Button.

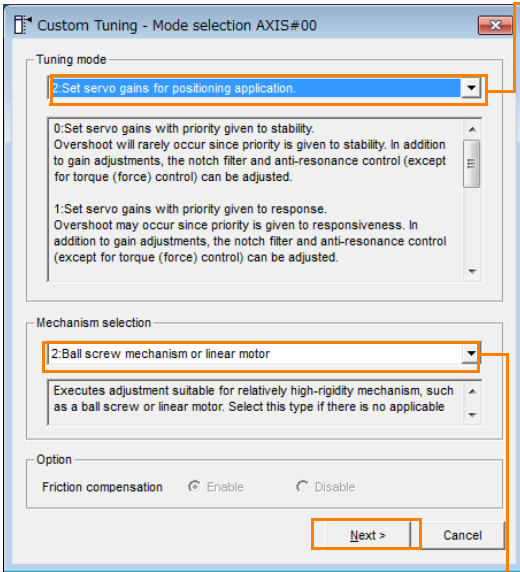

| Mode Selection  | Description  |
|---|--|
| 0: Set servo gains with priority given to stability.                                  | This setting gives priority to stability and preventing overshooting. In addition to gain adjustment, notch filters and anti-resonance control (except during torque control) are automatically adjusted.  |
| 1: Set servo gains with priority given to response.                                   | Overshooting may occur because priority is given to response. In addition to gain adjustment, notch filters and anti-resonance control (except during torque control) are automatically adjusted.          |
| 2: Set servo gains for positioning application.                                       | Tuning is performed for positioning applications. In addition to gain adjustment, notch filters, anti-resonance control, and vibration suppression are adjusted.   |
| 3: Set servo gains especially to prevent overshooting during positioning application. | Tuning is performed for positioning applications with emphasis on eliminating overshooting. In addition to gain adjustment, notch filters, anti-resonance control, and vibration suppression are adjusted. |

• **Mechanism Selection Box**

Select the type according to the machine element to drive. If there is noise or if the gain does not increase, better results may be obtained by changing the rigidity type. Select the type according to the following guidelines.

| Mechanism Selection                     | Description  |
|---|--|
| 1: Belt mechanism                       | Tuning is performed for a mechanism with relatively low rigidity, e.g., a belt.  |
| 2: Ball screw mechanism or Linear motor | Tuning is performed for a mechanism with relatively high rigidity, e.g., a ball screw or Linear Servomotor. Use this setting if there is no other appropriate setting. |
| 3: Rigid body system                    | Tuning is performed for a mechanism with high rigidity, e.g., a rigid body system.   |

**Information** The tuning modes that you can select depend on the SERVOPACK setting.

- If the moment of inertia ratio is not set correctly, correct the setting and then click the Next Button.

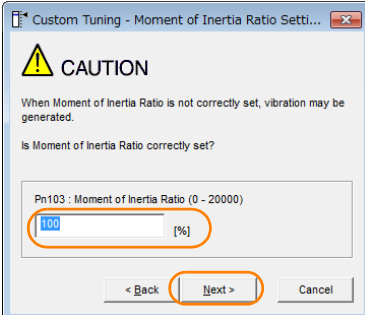

9. Turn ON the servo, enter a reference from the host controller, and then click the **Start tuning Button**.

Tuning Mode 0 or 1

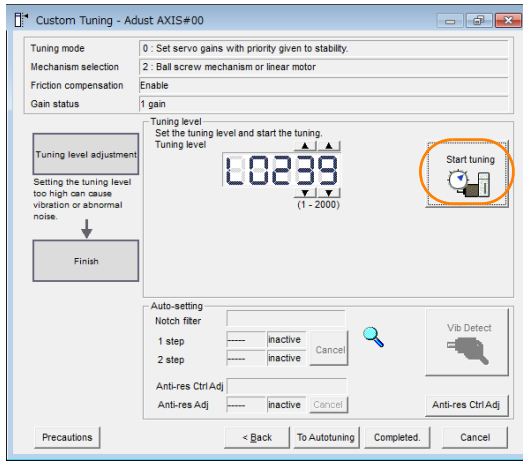

Tuning Mode 2 or 3

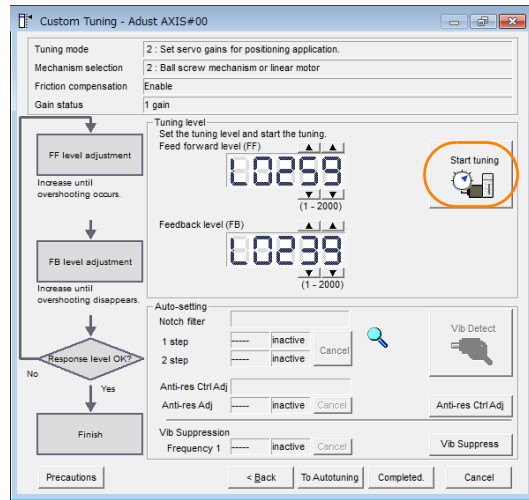

10. Use the ▲ and ▼ Buttons to change the tuning level.

Click the **Back** Button during tuning to restore the setting to its original value. The tuning level will return to the value from before when custom tuning was started.

Tuning Mode 0 or 1

Increase the tuning level until overshooting occurs.

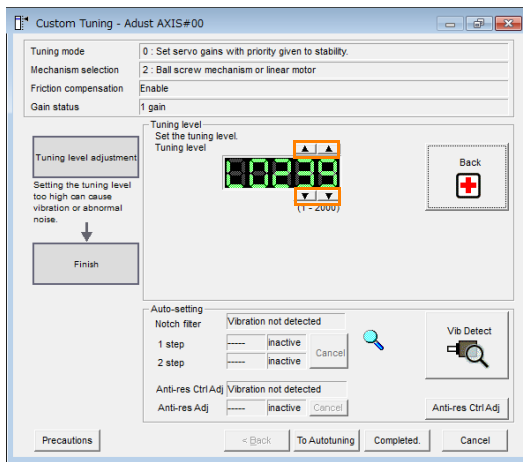

Tuning Mode 2 or 3

Increase the feedforward level until overshoot occurs and then increase the feedback level until overshooting is eliminated. Repeat these changes to make the adjustment.

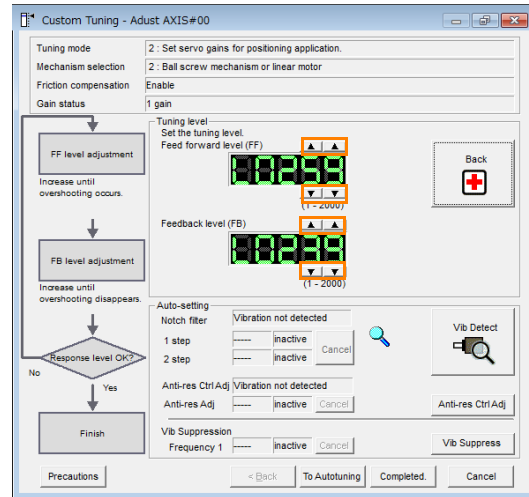

**Information** The new feedforward level will not be used until the positioning completed signal is output.

11. You can set the functions to suppress vibration (notch filters, automatic anti-resonance control setting, anti-resonance control adjustment, and autotuning with a host reference) as required.

Refer to the following section for details.

*Vibration Suppression Functions* on page 9-47



## 12. When tuning has been completed, click the **Completed** Button.

The values that were changed will be saved in the SERVOPACK and you will return to the Tuning Dialog Box.

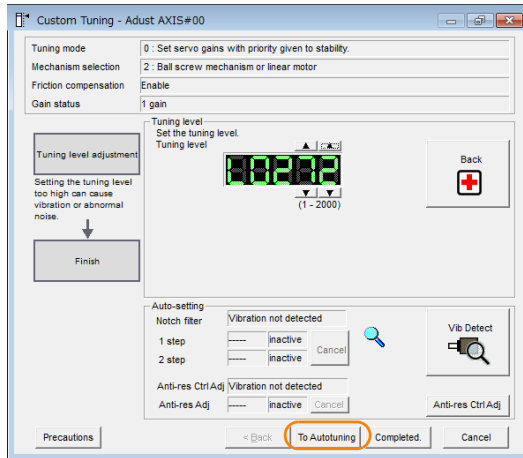

This concludes the procedure to set up custom tuning.

## Vibration Suppression Functions

### ◆ Notch Filters and Automatic Anti-resonance Control Setting

If the vibration frequency that occurs when you increase the servo gains is at 1,000 Hz or higher, notch filters are effective to suppress vibration. If the vibration is between 100 Hz and 1,000 Hz, anti-resonance control is effective.

### ◆ Automatic Setting

To set vibration suppression automatically, use the parameters to enable notch filters and automatic anti-resonance control setting.

The notch filter frequency (stage 1 or 2) or anti-resonance control frequency that is effective for the vibration that was detected during tuning will be automatically set.

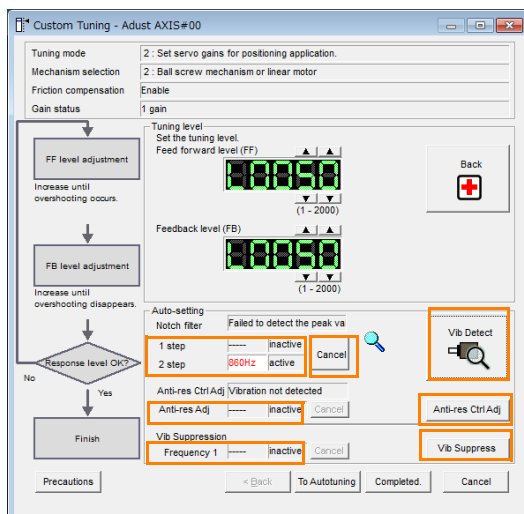

### • **Auto-setting Cancel** Buttons

The automatically set notch filter frequencies or the anti-resonance control frequencies may not always suppress vibration. Click the **Cancel** Button to reset the notch filter frequencies or the anti-resonance control frequencies to the values from just before these frequencies were set automatically.

When they are reset, vibration detection will start again.

• **Vib Detect** Button

While the notch filter or automatic anti-resonance control setting function is enabled, you can click the **Vib Detect** Button to manually detect vibration. When you click the **Vib Detect** Button, the SERVOPACK will detect vibration at that time, and set the notch filter frequency (stage 1 or 2) or anti-resonance control frequency that is effective for the detected vibration. You can also perform manual vibration detection even when the SERVOPACK does not detect vibration.

• **Anti-res Ctrl Adj** Button

You can use the **Anti-res Ctrl Adj** Button to execute the anti-resonance control adjustment if fine-tuning is required. Refer to the following section.

 9.9 Anti-Resonance Control Adjustment on page 9-50

• **Vib Suppress** Button

Click the **Vib Suppress** Button to suppress low and transient vibration (oscillation) of approximately 1 Hz to 100 Hz that occurs during positioning. Refer to the following section.

 9.10 Vibration Suppression on page 9-55

◆ **Autotuning with a Host Reference**

You can perform autotuning with a host reference. Refer to the following section for details.

 9.7 Autotuning with a Host Reference on page 9-35

**9.8.5 Automatically Adjusted Function Settings**

You cannot use vibration suppression functions at the same time. Other automatic function settings are the same as for autotuning without a host reference. Refer to the following section.

 9.6.6 Automatically Adjusted Function Settings on page 9-32

**9.8.6 Tuning Example for Tuning Mode 2 or 3**

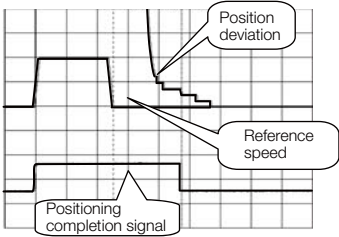
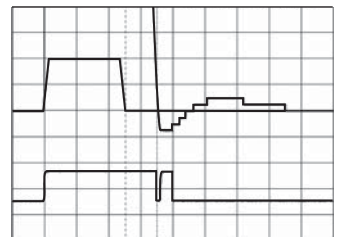
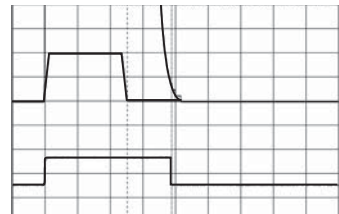
| Step | Measurement Display Examples  | Operation   |
|------|---|---|
| 1    |  | <p>The positioning time is measured after the moment of inertia ratio (Pn103) is set correctly. Tuning is completed if the specifications are met. The tuning results are saved in the SERVOPACK.</p>   |
| 2    |  | <p>The positioning time will be reduced if the feedforward level is increased. Tuning is completed if the specifications are met. The tuning results are saved in the SERVOPACK. If overshooting occurs before the specifications are met, proceed to step 3.</p> |
| 3    |  | <p>Overshooting will be reduced if the feedback level is increased. If the overshooting is eliminated, proceed to step 4.</p>   |

Continued on next page.

Continued from previous page.

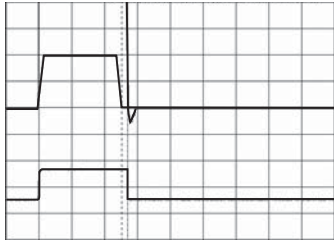
| Step | Measurement Display Examples  | Operation   |
|------|---|---|
| 4    |  | The graph shows overshooting that occurred when the feed-forward level was increased even more after step 3. In this state, overshooting occurs, but the positioning settling time is shorter. Tuning is completed if the specifications are met. The tuning results are saved in the SERVOPACK. If overshooting occurs before the specifications are met, repeat steps 3 and 4.<br>If vibration occurs before the overshooting is eliminated, the vibration is suppressed with the notch filters and anti-resonance control. |
| 5    | –   | The tuning results are saved in the SERVOPACK.  |

## 9.8.7 Related Parameters

The following parameters are automatically adjusted or used as reference when you execute custom tuning.

Do not change the settings while custom tuning is being executed.

| Parameter     | Name  | Automatic Changes |
|---------------|---|-------------------|
| Pn100 (2100h) | Speed Loop Gain   | Yes               |
| Pn101 (2101h) | Speed Loop Integral Time Constant                       | Yes               |
| Pn102 (2102h) | Position Loop Gain                                      | Yes               |
| Pn103 (2103h) | Moment of Inertia Ratio                                 | No                |
| Pn121 (2121h) | Friction Compensation Gain                              | Yes               |
| Pn123 (2123h) | Friction Compensation Coefficient                       | Yes               |
| Pn124 (2124h) | Friction Compensation Frequency Correction              | No                |
| Pn125 (2125h) | Friction Compensation Gain Correction                   | Yes               |
| Pn401 (2401h) | First Stage First Torque Reference Filter Time Constant | Yes               |
| Pn408 (2408h) | Torque-Related Function Selections                      | Yes               |
| Pn409 (2409h) | First Stage Notch Filter Frequency                      | Yes               |
| Pn40A (240Ah) | First Stage Notch Filter Q Value                        | Yes               |
| Pn40C (240Ch) | Second Stage Notch Filter Frequency                     | Yes               |
| Pn40D (240Dh) | Second Stage Notch Filter Q Value                       | Yes               |
| Pn140 (2140h) | Model Following Control-Related Selections              | Yes               |
| Pn141 (2141h) | Model Following Control Gain                            | Yes               |
| Pn142 (2142h) | Model Following Control Gain Correction                 | Yes               |
| Pn143 (2143h) | Model Following Control Bias in the Forward Direction   | Yes               |
| Pn144 (2144h) | Model Following Control Bias in the Reverse Direction   | Yes               |
| Pn145 (2145h) | Vibration Suppression 1 Frequency A                     | No                |
| Pn146 (2146h) | Vibration Suppression 1 Frequency B                     | No                |
| Pn147 (2147h) | Model Following Control Speed Feedforward Compensation  | Yes               |
| Pn160 (2160h) | Anti-Resonance Control-Related Selections               | Yes               |
| Pn161 (2161h) | Anti-Resonance Frequency                                | Yes               |
| Pn163 (2163h) | Anti-Resonance Damping Gain                             | Yes               |

Yes: The parameter is automatically set.

No: The parameter is not automatically set, but the setting is read during execution.

## 9.9 Anti-Resonance Control Adjustment

This section describes anti-resonance control.

### 9.9.1 Outline

Anti-resonance control increases the effectiveness of vibration suppression after custom tuning.

Anti-resonance control is effective for suppression of continuous vibration frequencies from 100 to 1,000 Hz that occur when the control gain is increased. Vibration can be eliminated by setting vibration frequencies through automatic detection or by manually setting them to adjust the damping gain. Input an operation reference and execute this anti-resonance control adjustment when there is vibration.

Anti-resonance control is automatically set by autotuning without a host reference or autotuning with a host reference. Use anti-resonance control adjustment only if fine-tuning is required or readjustment is required as a result of a failure to detect vibration.

Perform custom tuning if required to increase the response after performing anti-resonance control adjustment. If the control gain is increased, e.g., when custom tuning is performed, vibration may occur again. If that occurs, perform anti-resonance control adjustment again to fine-tune the parameters.



### CAUTION

- Related parameters will be set automatically when anti-resonance control adjustment is executed. This may greatly affect the response before and after execution. Make sure that you can perform an emergency stop at any time.
- Before you execute anti-resonance control adjustment, set the correct moment of inertia ratio (Pn103). If the setting greatly differs from the actual moment of inertia ratio, normal control of the machine may not be possible, and vibration may occur.



Important

- Anti-resonance control adjustment detects vibration frequencies between 100 Hz and 1,000 Hz. If the vibration frequency is not within this range, use custom tuning with tuning mode 2 selected to automatically set a notch filter or use vibration suppression.
- Vibration reduction can be made more effective by increasing the anti-resonance damping gain (Pn163), but the vibration may become larger if the damping gain is too high. Increase the damping gain by approximately 0% to 200% in 10% increments while checking the effect on vibration. If vibration reduction is still insufficient at a gain of 200%, cancel the setting, and lower the control gain by using a different method, such as custom tuning.



### 9.9.2 Preparations

Check the following settings before you execute anti-resonance control adjustment.

- The tuning-less function must be disabled (Pn170 = n.□□□0).
- The test without a motor function must be disabled (Pn00C = n.□□□0).
- The control method must not be set to torque control.
- The parameters must not be write prohibited.

## 9.9.3 Applicable Tools

The following table lists the tools that you can use to perform anti-resonance control adjustment.

| Tool             | Fn No./Function Name   | Operating Procedure Reference  |
|------------------|------------------------|--|
| Digital Operator | Fn204                  |  $\Sigma$ -7-Series Digital Operator Operating Manual (Manual No.: SIEP S800001 33) |
| SigmaWin+        | <i>Tuning - Tuning</i> |  9.9.4 Operating Procedure on page 9-51   |

## 9.9.4 Operating Procedure

To execute anti-resonance control adjustment, an operation reference is input, and the adjustment is executed while vibration is occurring.

The following methods can be used to execute anti-resonance control adjustment.

- To automatically detect the vibration frequency
- To manually set the vibration frequency

Use the following procedure.

### CAUTION

- Before you execute anti-resonance control adjustment, check the information provided in the SigmaWin+ operating manual. Observe the following precautions.
  - Make sure that you can perform an emergency stop at any time. Parameters will be set automatically when anti-resonance control adjustment is executed. This may greatly affect the response before and after execution. Make sure that you can perform an emergency stop (to turn OFF the power supply) at any time.
  - Set the moment of inertia correctly before you execute anti-resonance control adjustment. If the setting greatly differs from the actual moment of inertia, effective vibration reduction may not be possible.
  - If you have already performed anti-resonance control adjustment and then you change the frequency, the current anti-resonance control effect may be lost. Caution is particularly required when automatically detecting the vibration frequency.
  - If effective vibration reduction is not achieved even after you execute anti-resonance control adjustment, cancel the function and lower the control gain by using a different method, such as custom tuning.
  - Perform custom tuning separately if required to increase the response after performing anti-resonance control adjustment. If the servo gain is increased, e.g., when custom tuning is performed, vibration may occur again. If that occurs, perform anti-resonance control adjustment again to fine-tune the parameters.

1. Perform steps 1 to 8 of the procedure for custom tuning. Refer to the following section for details.

9.8.4 Operating Procedure on page 9-43

2. Click the **Anti-res Ctrl Adj Button**.

The rest of the procedure depends on whether you know the vibration frequency.

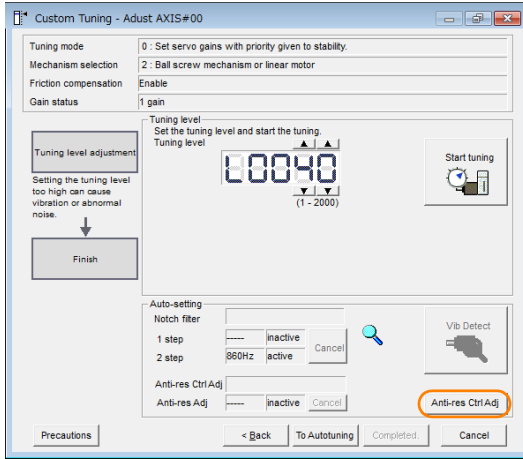

3. If you do not know the vibration frequency, click the **Auto Detect Button**. If you know the vibration frequency, click the **Manual Set Button**.

To Automatically Detect the Vibration Frequency

The frequency will be set.

To Manually Set the Vibration Frequency

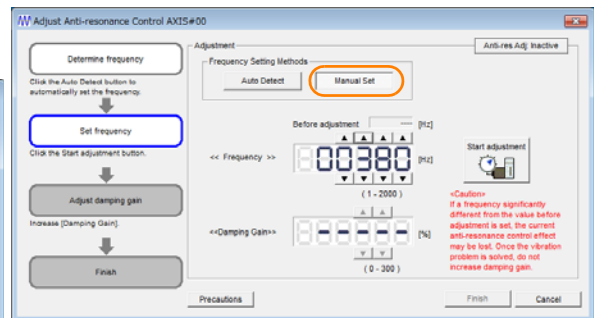

4. Click the **Start adjustment Button**.

5. Use the **▲** and **▼** Buttons in the **Adjustment Area** to change the settings.

Click the **Reset Button** during tuning to restore the setting to its original value. The tuning level will return to the value from before when custom tuning was started.

To Automatically Detect the Vibration Frequency

Change the setting of the damping gain.

To Manually Set the Vibration Frequency

Change the settings of the frequency and damping gain.

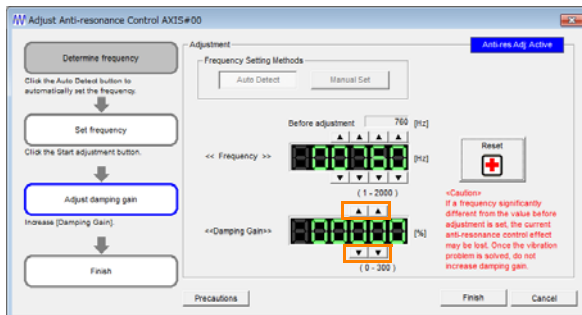

**6. When the adjustment has been completed, click the Finish Button.**

The values that were changed will be saved in the SERVOPACK and you will return to the Tuning Dialog Box.



This concludes the procedure to set up anti-resonance control.

## 9.9.5 Related Parameters

The following parameters are automatically adjusted or used as reference when you execute anti-resonance control adjustment.

Do not change the settings while anti-resonance control adjustment is being executed.

| Parameter     | Name   | Automatic Changes |
|---------------|--|-------------------|
| Pn160 (2160h) | Anti-Resonance Control-Related Selections        | Yes               |
| Pn161 (2161h) | Anti-Resonance Frequency                         | Yes               |
| Pn162 (2162h) | Anti-Resonance Gain Correction                   | No                |
| Pn163 (2163h) | Anti-Resonance Damping Gain                      | Yes               |
| Pn164 (2164h) | Anti-Resonance Filter Time Constant 1 Correction | No                |
| Pn165 (2165h) | Anti-Resonance Filter Time Constant 2 Correction | No                |

Yes: The parameter is automatically set.

No: The parameter is not automatically set, but the setting is read during execution.

## 9.9.6 Suppressing Different Vibration Frequencies with Anti-resonance Control

When you use anti-resonance control and increase the control gain, for some mechanism, vibration can occur at a higher frequency than the frequency for which vibration was suppressed. If this occurs, you can suppress vibration for more than one frequency by adjusting Pn166 (Anti-Resonance Damping Gain 2).

**Information**

**Guidelines for Vibration That Can Be Suppressed**

Anti-resonance frequency (Pn161):  $f_a$  [Hz], Another vibration frequency that occurs when the control gain is increased:  $f_b$  [Hz]

- Vibration frequencies: 100 Hz to 1,000 Hz
- Range of different vibration frequencies:  $1 < (f_b/f_a) \leq 3$  to 4

## Required Parameter Settings

The following parameter settings are required to use anti-resonance control for more than one vibration frequency.

| Parameter        |  | Description                        | When Enabled    | Classification              |
|------------------|--|------------------------------------|-----------------|-----------------------------|
| Pn160<br>(2160h) | n.□□□0<br>(default setting)                      | Do not use anti-resonance control. | After restart   | Setup                       |
|                  | n.□□□1   | Use anti-resonance control.        |                 |                             |
| Pn161<br>(2161h) | Anti-Resonance Frequency                         |                                    |                 | [Speed] [Position] [Torque] |
|                  | Setting Range                                    | Setting Unit                       | Default Setting | When Enabled                |
|                  | 10 to 20,000                                     | 0.1 Hz                             | 1000            | Immediately                 |
| Pn162<br>(2162h) | Anti-Resonance Gain Correction                   |                                    |                 | [Speed] [Position] [Torque] |
|                  | Setting Range                                    | Setting Unit                       | Default Setting | When Enabled                |
|                  | 1 to 1,000                                       | 1%                                 | 100             | Immediately                 |
| Pn163<br>(2163h) | Anti-Resonance Damping Gain                      |                                    |                 | [Speed] [Position] [Torque] |
|                  | Setting Range                                    | Setting Unit                       | Default Setting | When Enabled                |
|                  | 0 to 300   | 1%                                 | 0               | Immediately                 |
| Pn164<br>(2164h) | Anti-Resonance Filter Time Constant 1 Correction |                                    |                 | [Speed] [Position] [Torque] |
|                  | Setting Range                                    | Setting Unit                       | Default Setting | When Enabled                |
|                  | -1,000 to 1,000                                  | 0.01 ms                            | 0               | Immediately                 |
| Pn165<br>(2165h) | Anti-Resonance Filter Time Constant 2 Correction |                                    |                 | [Speed] [Position] [Torque] |
|                  | Setting Range                                    | Setting Unit                       | Default Setting | When Enabled                |
|                  | -1,000 to 1,000                                  | 0.01 ms                            | 0               | Immediately                 |
| Pn166<br>(2166h) | Anti-Resonance Damping Gain 2                    |                                    |                 | [Speed] [Position] [Torque] |
|                  | Setting Range                                    | Setting Unit                       | Default Setting | When Enabled                |
|                  | 0 to 1,000                                       | 1%                                 | 0               | Immediately                 |

## Adjustment Procedure for Suppressing Different Vibration Frequencies with Anti-resonance Control

Use the following procedure to make adjustments to suppress different vibration frequencies with anti-resonance control.

| Step | Operation   |
|------|---|
| 1    | Use the gain adjustment and anti-resonance control.<br>Refer to the following section for details.<br> 9.9.4 Operating Procedure on page 9-51  |
| 2    | If there is vibration at a higher frequency than the vibration suppressed with anti-resonance control in step 1, adjust Pn166 (Anti-Resonance Damping Gain 2).  |
| 3    | Adjust Pn166 (Anti-Resonance Damping Gain 2) while checking to see if vibration reduction is effective.<br>To adjust Pn166 (Anti-Resonance Damping Gain 2), increase the setting by 10% at a time starting from the value that resulted in Pn163 (Anti-Resonance Damping Gain) from the adjustment in step 1. |
| 4    | If the vibration disappears, the adjustment is completed.<br>However, if the vibration does not disappear even when you adjust Pn166 (Anti-Resonance Damping Gain 2), reduce the tuning level or feedback level until vibration does not occur.   |



## 9.10 Vibration Suppression

This section describes vibration suppression.

### 9.10.1 Outline

You can use vibration suppression to suppress transient vibration at a low frequency from 1 Hz to 100 Hz, which is generated mainly when the machine vibrates during positioning. This is effective for vibration frequencies for which notch filters and anti-resonance control adjustment are not effective.

Vibration suppression is automatically set by autotuning without a host reference or autotuning with a host reference. Use vibration suppression only if fine-tuning is required or readjustment is required as a result of a failure to detect vibration. To execute vibration suppression, input an operation reference and execute the function when there is vibration.

Perform custom tuning if required to increase the response after performing vibration suppression.

#### CAUTION

- Related parameters will be set automatically when vibration suppression is executed. This may greatly affect the response before and after execution. Make sure that you can perform an emergency stop at any time.
- Before you execute vibration suppression, set the correct moment of inertia ratio (Pn103) with autotuning without a host reference or another method. If the setting greatly differs from the actual moment of inertia ratio, normal control of the machine may not be possible, and vibration may occur.



Important

- Vibration suppression detects vibration frequencies between 1 Hz and 100 Hz.
- Frequency detection will not be performed if there is no vibration in the position deviation or if the vibration frequency is outside the range of detectable frequencies. If that is a problem, use a device such as a displacement meter or vibration sensor to measure the vibration frequency.
- If an automatically detected vibration frequency is not suppressed, the actual frequency and the detected frequency may be different. Fine-tune the detected frequency if necessary.

### Items That Influence Performance

If continuous vibration occurs while the Servomotor is stopping, vibration suppression cannot be used to suppress the vibration effectively. In this case, use anti-resonance control adjustment or custom tuning.

### Detection of Vibration Frequencies

Frequency detection may not be possible if vibration does not appear in the position deviation or the vibration that results from the position deviation is too small. You can adjust the detection sensitivity by changing the setting of the residual vibration detection width (Pn560), which is set as a percentage of the positioning completed width (Pn522). Perform the detection of vibration frequencies again after adjusting the setting of Pn560.

| Pn560<br>(2560h) | Residual Vibration Detection Width |              |                 |              | Position       |
|------------------|------------------------------------|--------------|-----------------|--------------|----------------|
|                  | Setting Range                      | Setting Unit | Default Setting | When Enabled | Classification |
|                  | 1 to 3,000                         | 0.1%         | 400             | Immediately  | Setup          |

Note: As a guideline, change the setting 10% at a time. If the setting of this parameter is lowered, the detection sensitivity will be increased. Vibration may not be detected accurately if the setting is too small.

#### Information

The vibration frequencies that are automatically detected may vary somewhat with each positioning operation. Perform positioning several times and make adjustments while checking the effect of vibration suppression.



## 9.10.2 Preparations

Check the following settings before you execute vibration suppression.

- Position control must be used.
- The tuning-less function must be disabled (Pn170 = n.□□□0).
- The test without a motor function must be disabled (Pn00C = n.□□□0).
- The parameters must not be write prohibited.

## 9.10.3 Applicable Tools

The following table lists the tools that you can use to perform vibration suppression.

| Tool             | Fn No./Function Name   | Operating Procedure Reference   |
|------------------|------------------------|---|
| Digital Operator | Fn205                  |  $\Sigma$ -7-Series Digital Operator Operating Manual (Manual No.: SIEP S80001 33) |
| SigmaWin+        | <i>Tuning - Tuning</i> |  9.10.4 Operating Procedure on page 9-56   |

## 9.10.4 Operating Procedure

Use the following procedure to perform vibration suppression.

1. Perform steps 1 to 8 of the procedure for custom tuning. Refer to the following section for details.

 9.8.4 Operating Procedure on page 9-43

2. Click the **Vib Suppress** Button.

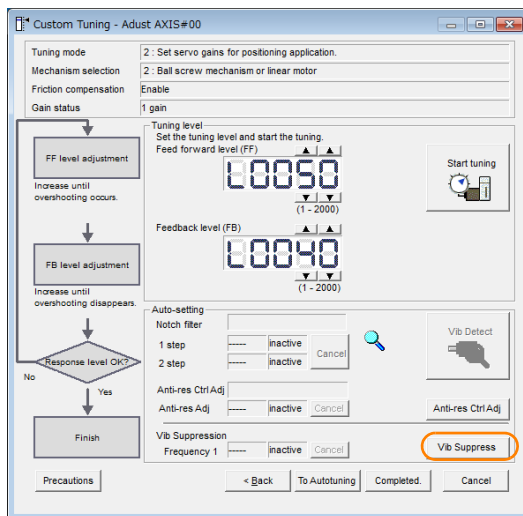

3. Click the **Import Button** or click **▲** and **▼** Button to manually adjust the set frequency. When you click the **Import Button**, the residual vibration frequency in the motor is read as the set frequency. (The frequency can be read only when the residual vibration frequency is between 1.0 and 100.0.)



Important

Frequency detection will not be performed if there is no vibration or if the vibration frequency is outside the range of detectable frequencies. If a vibration frequency is not detected, provide a means of measuring the vibration frequency.

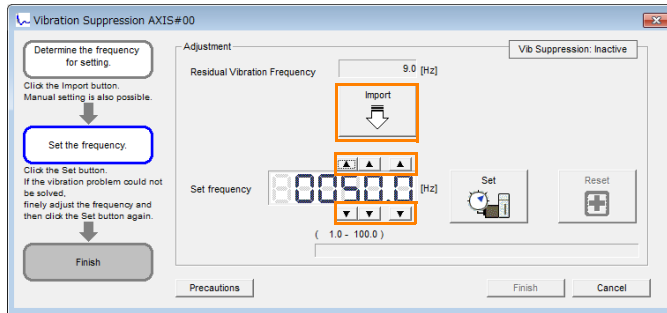

4. Click the **Set Button**.



Important

No settings related to vibration suppression are changed during operation. If the Servomotor does not stop within approximately 10 seconds after changing the setting, an update timeout will occur. The setting will be automatically returned to the previous value.

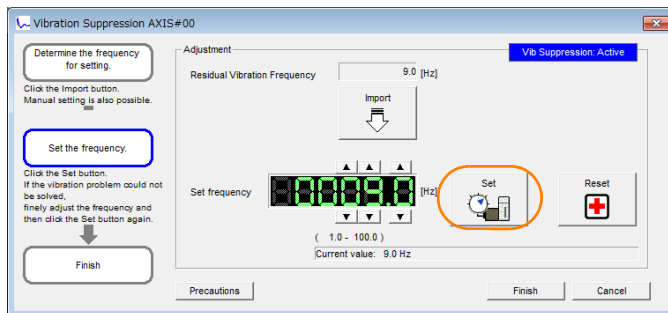

If the vibration is not eliminated, use the **▲** and **▼** Buttons for the set frequency to fine-tune the value and click the **Set Button** again.

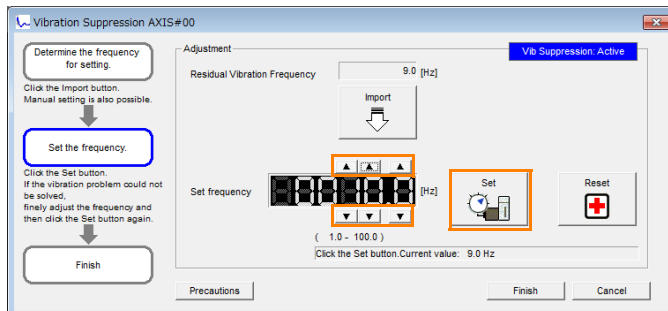

Click the **Reset Button** during adjustment to restore the setting to its original value. The status from before when adjustment was started will be restored.

**5. When the vibration has been eliminated, click the Finish Button.**

The updated value will be saved in the SERVOPACK.



Vibration suppression will be enabled in step 5. The motor response, however, will change when the Servomotor comes to a stop with no reference input.

This concludes the procedure to set up vibration suppression.

## 9.10.5 Setting Combined Functions

You can also use the feedforward function when you execute vibration suppression.

In the default settings, feedforward (Pn109), the speed feedforward input (VFF), and the torque feedforward input (TFF) are disabled.

To use the speed feedforward input (VFF), the torque feedforward input (TFF), and model following control from the host controller in the system, set Pn140 to n.1□□□ (Use model following control and speed/torque feedforward together).

| Parameter        |                             | Function  | When Enabled | Classification |
|------------------|-----------------------------|---|--------------|----------------|
| Pn140<br>(2140h) | n.0□□□<br>(default setting) | Do not use model following control and speed/torque feedforward together. | Immediately  | Tuning         |
|                  | n.1□□□                      | Use model following control and speed/torque feedforward together.        |              |                |



When model following control is used with the feedforward function, it is used to make optimum feedforward settings in the SERVOPACK. Therefore, model following control is not normally used together with either the speed feedforward input (VFF) or torque feedforward input (TFF) from the host controller. However, model following control can be used with the speed feedforward input (VFF) or torque feedforward input (TFF) if required. An unsuitable feedforward input may result in overshooting.

## 9.10.6 Related Parameters

The following parameters are automatically adjusted or used as reference when you execute vibration suppression.

Do not change the settings while vibration suppression is being executed.

| Parameter     | Name   | Automatic Changes |
|---------------|--|-------------------|
| Pn140 (2140h) | Model Following Control-Related Selections             | Yes               |
| Pn141 (2141h) | Model Following Control Gain                           | Yes               |
| Pn142 (2142h) | Model Following Control Gain Correction                | No                |
| Pn143 (2143h) | Model Following Control Bias in the Forward Direction  | No                |
| Pn144 (2144h) | Model Following Control Bias in the Reverse Direction  | No                |
| Pn145 (2145h) | Vibration Suppression 1 Frequency A                    | Yes               |
| Pn146 (2146h) | Vibration Suppression 1 Frequency B                    | Yes               |
| Pn147 (2147h) | Model Following Control Speed Feedforward Compensation | No                |
| Pn14A (214Ah) | Vibration Suppression 2 Frequency                      | No                |
| Pn14B (214Bh) | Vibration Suppression 2 Correction                     | No                |

Yes: The parameter is automatically set.

No: The parameter is not automatically set, but the setting is read during execution.

## 9.11 Speed Ripple Compensation

This section describes speed ripple compensation.

### 9.11.1 Outline

Speed ripple compensation reduces the amount of ripple in the motor speed due to torque ripple or cogging torque. You can enable speed ripple compensation to achieve smoother operation. To enable it, you must set up ripple compensation on the SigmaWin+.

#### WARNING

- Speed ripple compensation requires operating the motor and therefore presents hazards. Observe the following precaution.  
Confirm safety around moving parts.  
This function involves automatic operation. Make sure that you can perform an emergency stop (to turn OFF the power supply) at any time.



Important

- Execute speed ripple compensation only after adjusting the gains.
- Reset speed ripple compensation after you replace the Servomotor or SERVOPACK.
  - Execute speed ripple compensation after jogging to a position that ensures a suitable range of motion.

### 9.11.2 Setting Up Speed Ripple Compensation

#### Restrictions

The following restrictions apply to the setup for speed ripple compensation.

#### ◆ Systems for Which Execution Cannot Be Performed

There are no restrictions.

#### ◆ Systems for Which Adjustments Cannot Be Made Accurately

Systems for which there is not a suitable range of motion

#### ◆ Preparations

Check the following items before you set up speed ripple compensation.

- The main circuit power supply must be ON.
- The servo must be OFF.
- There must be no alarms or warnings.
- There must be no hard wire base block (HWBB).
- The parameters must not be write prohibited.

## Applicable Tools

The following table lists the tools that you can use to set up speed ripple compensation.

| Tool             | Fn No./Function Name   | Reference  |
|------------------|--|--|
| Digital Operator | You cannot set up speed ripple compensation from the Digital Operator. |  |
| SigmaWin+        | <b>Diagnostic – Ripple Compensation</b>                                |  Operating Procedure on page 9-60 |

## Operating Procedure

Use the following procedure to set up speed ripple compensation.

1. Click the  Servo Drive Button in the workspace of the Main Window of the SigmaWin+.
2. Select **Ripple Compensation** in the Menu Dialog Box. The Ripple Compensation Dialog Box will be displayed.
3. Click the **OK** Button.

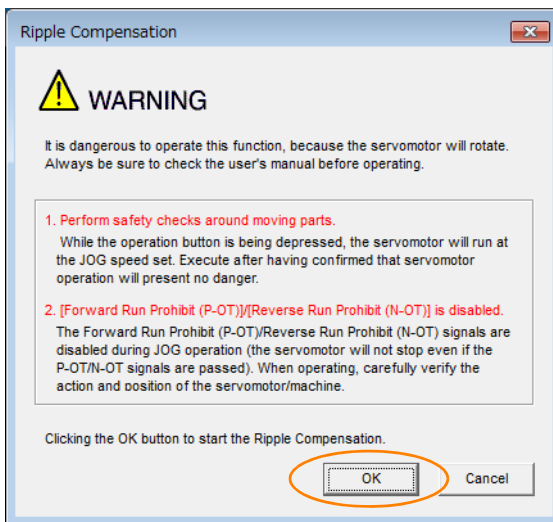

- Information**
1. Click the **Cancel** Button to cancel ripple compensation. The Main Window will return.
  2. If write protection is set, the following dialog box will be displayed.

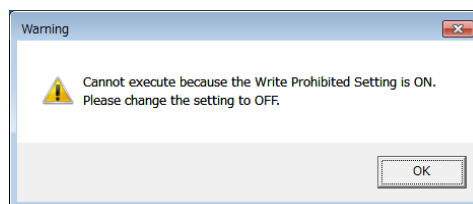

Click the **OK** Button to cancel write prohibition.

4. Click the **Edit Button**.

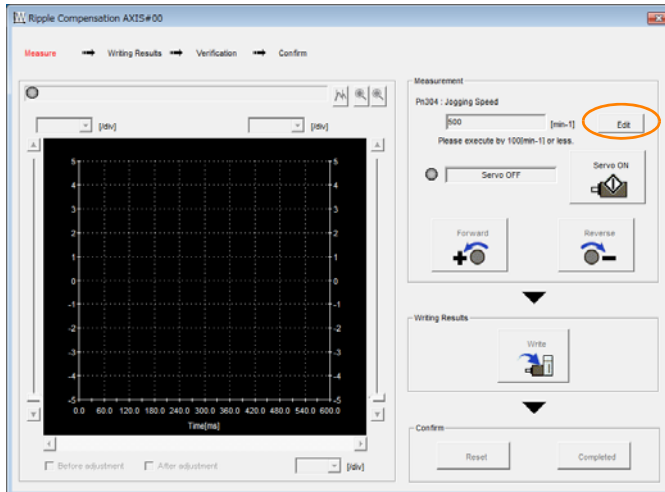

5. Enter the jogging speed in the **Input Value Box** and click the **OK Button**.

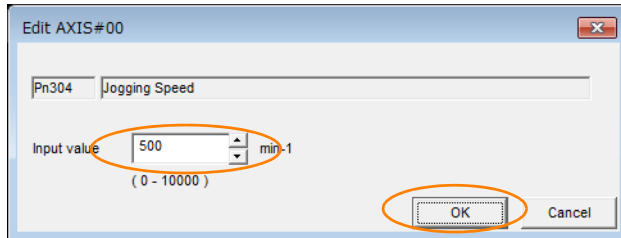

6. Click the **Servo ON Button**.

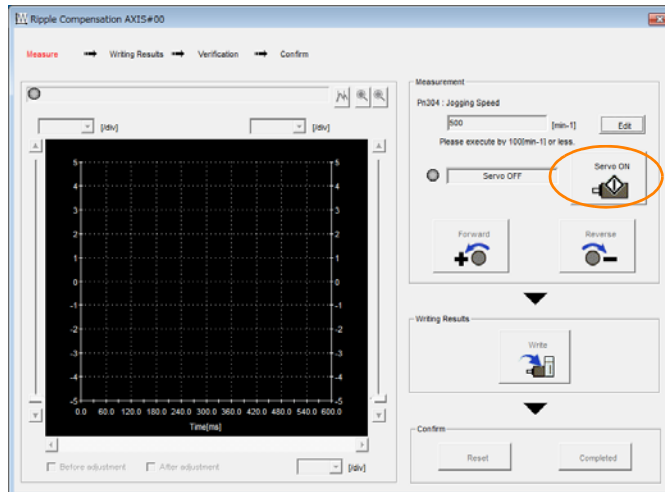



7. Click the **Forward Button** or the **Reverse Button**.

Measurement operation is started.

The motor shaft will rotate at the preset jogging speed while you hold down the **Forward** or **Reverse** Button and the speed ripple will be measured.

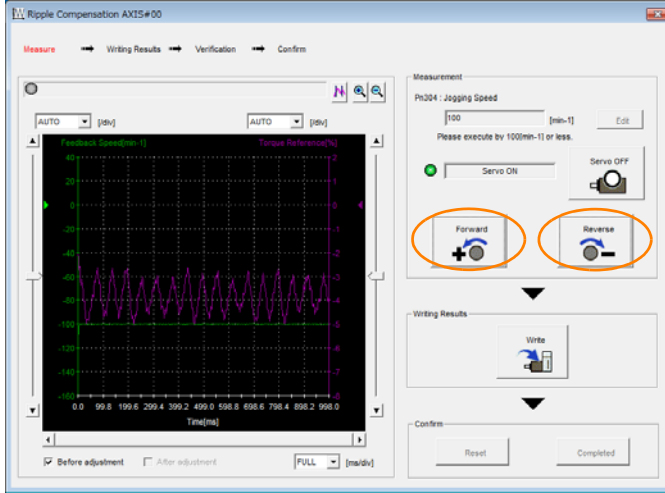
The feedback speed and torque reference graph will be displayed in the Ripple Compensation Dialog Box during jogging.



 **Important** If the measurement time (i.e., the jogging time) for the speed ripple is too short, speed ripple measurement will not be completed. The following dialog box will be displayed if speed ripple measurement was not completed. Click the **OK** Button and repeat the measurement.

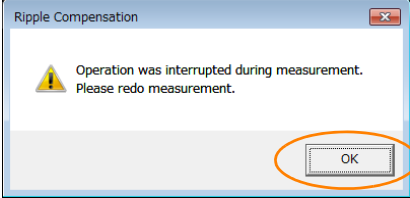

8. After speed ripple measurement has been completed, click the **Write Button**.

The ripple compensation value will be written to the SERVOPACK.

9. After writing has been completed, click the **OK** Button.

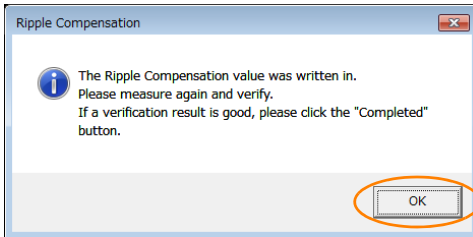



**10. Click the Forward Button or the Reverse Button.**

Verification operation is started.

The motor shaft will rotate at the preset jogging speed while you hold down the **Forward** or **Reverse** Button.

The waveform with speed ripple compensation applied to it will be displayed.

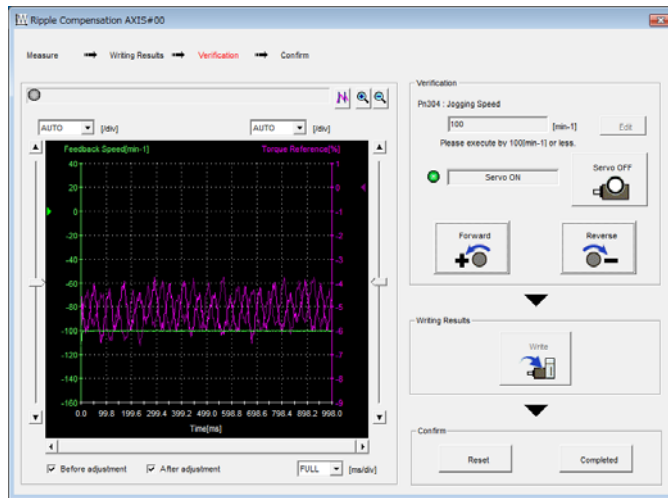

**11. If the verification results are OK, click the Finish Button.**

**Information** To discard the setup results, click the **Reset** Button.

This concludes the setup for speed ripple compensation.

## 9.11.3 Setting Parameters

The function is enabled when you perform the operating procedure on *Operating Procedure* on page 9-60. To cancel speed ripple compensation, use Pn423 = n.□□□0 (Disable speed ripple compensation) to disable it.

| Parameter        |                             | Description                        | When Enabled | Classification |
|------------------|-----------------------------|------------------------------------|--------------|----------------|
| Pn423<br>(2423h) | n.□□□0<br>(default setting) | Disable speed ripple compensation. | Immediately  | Setup          |
|                  | n.□□□1                      | Enable speed ripple compensation.  |              |                |

If you enable speed ripple compensation, a compensation reference will be applied to reduce ripple even when stopped at a 0 speed reference. In speed control mode, this may result in the motor moving slightly. To prevent this, set Pn423 = n.□X□□ (Speed Ripple Compensation Selections) and Pn427 or Pn49F (Speed Ripple Compensation Enable Speed).

| Parameter        |                             | Description     | When Enabled  | Classification |
|------------------|-----------------------------|-----------------|---------------|----------------|
| Pn423<br>(2423h) | n.□0□□<br>(default setting) | Speed reference | After restart | Setup          |
|                  | n.□1□□                      | Motor Speed     |               |                |

- For Rotary Servomotors

| Pn427<br>(2427h) | Speed Ripple Compensation Enable Speed |                     |                 |              |                |
|------------------|--|---------------------|-----------------|--------------|----------------|
|                  | Setting Range                          | Setting Unit        | Default Setting | When Enabled | Classification |
|                  | 0 to 10,000                            | 1 min <sup>-1</sup> | 0               | Immediately  | Tuning         |

- For Linear Servomotors

| Pn49F<br>(249Fh) | Speed Ripple Compensation Enable Speed |              |                 |              |                |
|------------------|--|--------------|-----------------|--------------|----------------|
|                  | Setting Range                          | Setting Unit | Default Setting | When Enabled | Classification |
|                  | 0 to 10,000                            | 1 mm/s       | 0               | Immediately  | Tuning         |

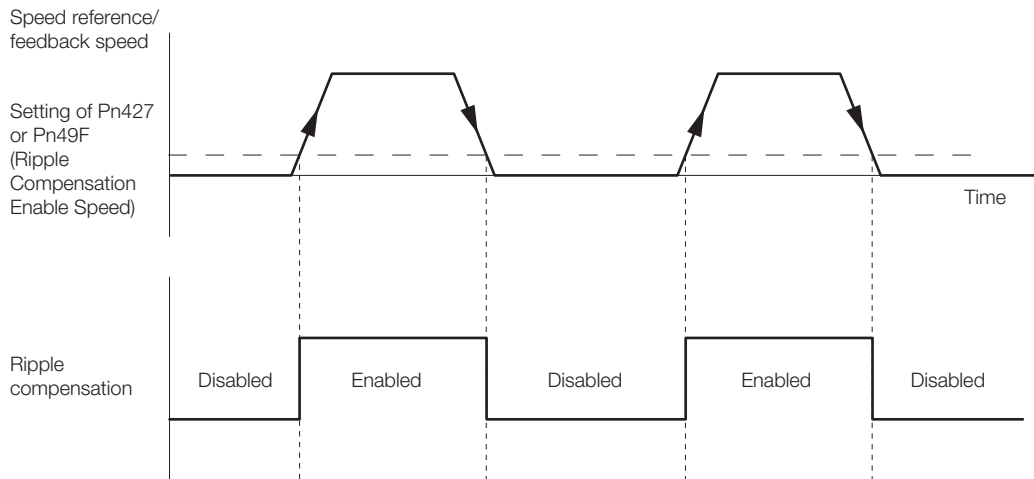

### Speed Ripple Compensation Warnings

The speed ripple compensation value is specific to each Servomotor. If you replace the Servomotor while speed ripple compensation is enabled, an A.942 warning (Speed Ripple Compensation Information Disagreement) will occur to warn you.

You can use any of the following methods to clear A.942.

- Reset the speed ripple compensation value on the SigmaWin+.
- Disable speed ripple compensation (Pn423 = n.□□□0).
- Disable detection of A.942 (Pn423 = n.□□1□).

| Parameter     |                          | Description                 | When Enabled  | Classification |
|---------------|--------------------------|-----------------------------|---------------|----------------|
| Pn423 (2423h) | n.□□0□ (default setting) | Detect A.942 alarms.        | After restart | Setup          |
|               | n.□□1□                   | Do not detect A.942 alarms. |               |                |

## 9.12 Additional Adjustment Functions

This section describes the functions that you can use to make adjustments after you perform autotuning without a host reference, autotuning with a host reference, and custom tuning.

| Function                         | Applicable Control Methods                          | Reference |
|----------------------------------|---|-----------|
| Gain Switching                   | Position control, speed control, or torque control* | page 9-65 |
| Friction Compensation            | Position control or speed control                   | page 9-68 |
| Current Control Mode Selection   | Position control, speed control, or torque control  | page 9-70 |
| Current Gain Level Setting       | Position control or speed control                   | page 9-71 |
| Speed Detection Method Selection | Position control, speed control, or torque control  | page 9-71 |
| Backlash Compensation            | Position Control                                    | page 9-72 |

\* Automatic gain switching is enabled only for position control.

### 9.12.1 Gain Switching

You can use gain switching to shorten the positioning time by increasing the gains during positioning and suppressing vibration by decreasing the gains while stopping.

| Parameter        | Function                    | When Enabled | Classification |
|------------------|-----------------------------|--------------|----------------|
| Pn139<br>(2139h) | n.□□□0<br>(default setting) | Immediately  | Tuning         |
|                  | n.□□□2                      |              |                |

Note: Pn139 = n.□□□1 is a reserved parameter. Do not change.

Refer to the following section for gain switching combinations.

 [Gain Switching Combinations](#) on page 9-65

### Gain Switching Combinations

| Selected Gains  | Speed Loop Gain                | Speed Loop Integral Time Constant                | Position Loop Gain                | Torque Reference Filter  | Friction Compensation Gain                |
|-----------------|--------------------------------|--|-----------------------------------|--|---|
| Gain Settings 1 | Speed Loop Gain (Pn100)        | Speed Loop Integral Time Constant (Pn101)        | Position Loop Gain (Pn102)        | First Stage First Torque Reference Filter Time Constant (Pn401)  | Friction Compensation Gain (Pn121)        |
| Gain Settings 2 | Second Speed Loop Gain (Pn104) | Second Speed Loop Integral Time Constant (Pn105) | Second Position Loop Gain (Pn106) | First Stage Second Torque Reference Filter Time Constant (Pn412) | Second Friction Compensation Gain (Pn122) |

Note: Automatic gain switching is not supported for Model Following Control Gain and Model Following Control Correction.

### Automatic Gain Switching

Automatic gain switching is enabled only for position control. The switching conditions are specified by using the following settings.

| Parameter        | Switching Condition       | Selected Gains                     | Switching Waiting Time                 | Switching Time                 |
|------------------|---------------------------|------------------------------------|--|--------------------------------|
| Pn139<br>(2139h) | n.□□□2                    | Gain settings 1 to gain settings 2 | Gain Switching Waiting Time 1<br>Pn135 | Gain Switching Time 1<br>Pn131 |
|                  | Condition A not satisfied | Gain settings 2 to gain settings 1 | Gain Switching Waiting Time 2<br>Pn136 | Gain Switching Time 2<br>Pn132 |

Select one of the following settings for switching condition A.

| Parameter     | Position Control Gain Switching Condition A | For Control Methods Other Than Position Control (No Switching)             | When Enabled          | Classification |        |
|---------------|---|--|-----------------------|----------------|--------|
| Pn139 (2139h) | n.□□0□ (default setting)                    | /COIN (Positioning Completion) signal ON                                   | Gain settings 1 used. | Immediately    | Tuning |
|               | n.□□1□                                      | /COIN (Positioning Completion) signal OFF                                  | Gain settings 2 used. |                |        |
|               | n.□□2□                                      | /NEAR (Near) signal ON   | Gain settings 1 used. |                |        |
|               | n.□□3□                                      | /NEAR (Near) signal OFF  | Gain settings 2 used. |                |        |
|               | n.□□4□                                      | Position reference filter output is 0 and position reference input is OFF. | Gain settings 1 used. |                |        |
|               | n.□□5□                                      | Position reference input is ON.  | Gain settings 2 used. |                |        |

Automatic Switching Pattern 1 (Pn139 = n.□□□2)

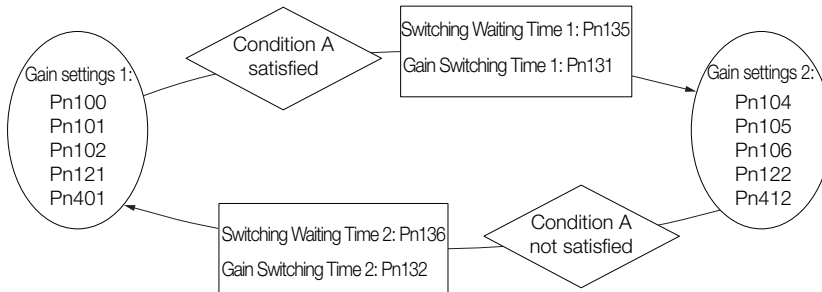

### ◆ Relationship between the Waiting Times and Switching Times for Gain Switching

In this example, an ON /COIN (Positioning Completion) signal is set as condition A for automatic gain switching. The position loop gain is changed from the value in Pn102 (Position Loop Gain) to the value in Pn106 (Second Position Loop Gain). When the /COIN signal turns ON, the switching operation begins after the waiting time (Pn135). The switching operation changes the position loop gain linearly from the gain set in Pn102 to the gain set in Pn106 over the switching time (Pn131).

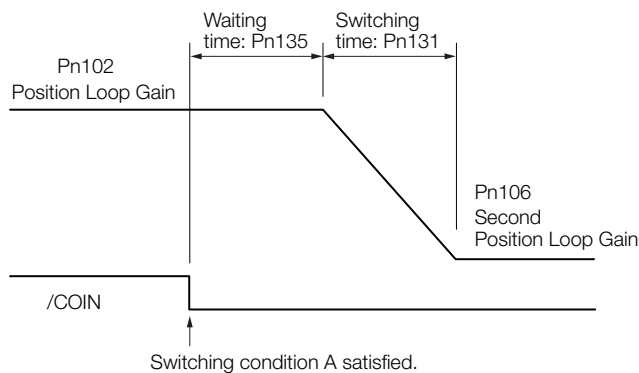

**Information** You can use gain switching for either PI control or I-P control (Pn10B = n.□□0□ or □□1□).

## Related Parameters

|                  |   |              |                 |              |                |
|------------------|---|--------------|-----------------|--------------|----------------|
| Pn100<br>(2100h) | Speed Loop Gain <span style="float:right">[Speed] [Position]</span>   |              |                 |              |                |
|                  | Setting Range   | Setting Unit | Default Setting | When Enabled | Classification |
|                  | 10 to 20,000  | 0.1 Hz       | 400             | Immediately  | Tuning         |
| Pn101<br>(2101h) | Speed Loop Integral Time Constant <span style="float:right">[Speed] [Position]</span>                                 |              |                 |              |                |
|                  | Setting Range   | Setting Unit | Default Setting | When Enabled | Classification |
|                  | 15 to 51,200  | 0.01 ms      | 2,000           | Immediately  | Tuning         |
| Pn102<br>(2102h) | Position Loop Gain <span style="float:right">[Position]</span>  |              |                 |              |                |
|                  | Setting Range   | Setting Unit | Default Setting | When Enabled | Classification |
|                  | 10 to 20,000  | 0.1/s        | 400             | Immediately  | Tuning         |
| Pn401<br>(2401h) | First Stage First Torque Reference Filter Time Constant <span style="float:right">[Speed] [Position] [Torque]</span>  |              |                 |              |                |
|                  | Setting Range   | Setting Unit | Default Setting | When Enabled | Classification |
|                  | 0 to 65,535   | 0.01 ms      | 100             | Immediately  | Tuning         |
| Pn121<br>(2121h) | Friction Compensation Gain <span style="float:right">[Speed] [Position]</span>  |              |                 |              |                |
|                  | Setting Range   | Setting Unit | Default Setting | When Enabled | Classification |
|                  | 10 to 1,000   | 1%           | 100             | Immediately  | Tuning         |
| Pn104<br>(2104h) | Second Speed Loop Gain <span style="float:right">[Speed] [Position]</span>  |              |                 |              |                |
|                  | Setting Range   | Setting Unit | Default Setting | When Enabled | Classification |
|                  | 10 to 20,000  | 0.1 Hz       | 400             | Immediately  | Tuning         |
| Pn105<br>(2105h) | Second Speed Loop Integral Time Constant <span style="float:right">[Speed] [Position]</span>                          |              |                 |              |                |
|                  | Setting Range   | Setting Unit | Default Setting | When Enabled | Classification |
|                  | 15 to 51,200  | 0.01 ms      | 2,000           | Immediately  | Tuning         |
| Pn106<br>(2106h) | Second Position Loop Gain <span style="float:right">[Position]</span>   |              |                 |              |                |
|                  | Setting Range   | Setting Unit | Default Setting | When Enabled | Classification |
|                  | 10 to 20,000  | 0.1/s        | 400             | Immediately  | Tuning         |
| Pn412<br>(2412h) | First Stage Second Torque Reference Filter Time Constant <span style="float:right">[Speed] [Position] [Torque]</span> |              |                 |              |                |
|                  | Setting Range   | Setting Unit | Default Setting | When Enabled | Classification |
|                  | 0 to 65,535   | 0.01 ms      | 100             | Immediately  | Tuning         |
| Pn122<br>(2122h) | Second Friction Compensation Gain <span style="float:right">[Speed] [Position]</span>                                 |              |                 |              |                |
|                  | Setting Range   | Setting Unit | Default Setting | When Enabled | Classification |
|                  | 10 to 1,000   | 1%           | 100             | Immediately  | Tuning         |

## Parameters Related to Automatic Gain Switching

|                  |   |              |                 |              |                |
|------------------|---|--------------|-----------------|--------------|----------------|
| Pn131<br>(2131h) | Gain Switching Time 1 <span style="float:right">[Position]</span>         |              |                 |              |                |
|                  | Setting Range   | Setting Unit | Default Setting | When Enabled | Classification |
|                  | 0 to 65,535   | 1 ms         | 0               | Immediately  | Tuning         |
| Pn132<br>(2132h) | Gain Switching Time 2 <span style="float:right">[Position]</span>         |              |                 |              |                |
|                  | Setting Range   | Setting Unit | Default Setting | When Enabled | Classification |
|                  | 0 to 65,535   | 1 ms         | 0               | Immediately  | Tuning         |
| Pn135<br>(2135h) | Gain Switching Waiting Time 1 <span style="float:right">[Position]</span> |              |                 |              |                |
|                  | Setting Range   | Setting Unit | Default Setting | When Enabled | Classification |
|                  | 0 to 65,535   | 1 ms         | 0               | Immediately  | Tuning         |
| Pn136<br>(2136h) | Gain Switching Waiting Time 2 <span style="float:right">[Position]</span> |              |                 |              |                |
|                  | Setting Range   | Setting Unit | Default Setting | When Enabled | Classification |
|                  | 0 to 65,535   | 1 ms         | 0               | Immediately  | Tuning         |

## Related Monitoring

- SigmaWin+  
You can monitor gain switching with the status monitor or with tracing.
- Analog Monitors

| Parameter     | Analog Monitor | Monitor Name        | Output Value | Description                  |
|---------------|----------------|---------------------|--------------|------------------------------|
| Pn006 (2006h) | n.□□0B         | Active Gain Monitor | 1 V          | Gain settings 1 are enabled. |
| Pn007 (2007h) |                |                     | 2 V          | Gain settings 2 are enabled. |

## 9.12.2 Friction Compensation

Friction compensation is used to compensate for viscous friction fluctuations and regular load fluctuations.

You can automatically adjust friction compensation with autotuning without a host reference, autotuning with a host reference, or custom tuning, or you can manually adjust it with the following procedure.

### Required Parameter Settings

The following parameter settings are required to use friction compensation.

| Parameter        | Function                                   |                                |                 | When Enabled | Classification |       |
|------------------|--|--------------------------------|-----------------|--------------|----------------|-------|
| Pn408<br>(2408h) | n.0□□□<br>(default setting)                | Disable friction compensation. |                 |              | Immediately    | Setup |
|                  | n.1□□□                                     | Enable friction compensation.  |                 |              |                |       |
| Pn121<br>(2121h) | Friction Compensation Gain                 |                                |                 | Speed        | Position       |       |
|                  | Setting Range                              | Setting Unit                   | Default Setting | When Enabled | Classification |       |
|                  | 10 to 1,000                                | 1%                             | 100             | Immediately  | Tuning         |       |
| Pn122<br>(2122h) | Second Friction Compensation Gain          |                                |                 | Speed        | Position       |       |
|                  | Setting Range                              | Setting Unit                   | Default Setting | When Enabled | Classification |       |
|                  | 10 to 1,000                                | 1%                             | 100             | Immediately  | Tuning         |       |
| Pn123<br>(2123h) | Friction Compensation Coefficient          |                                |                 | Speed        | Position       |       |
|                  | Setting Range                              | Setting Unit                   | Default Setting | When Enabled | Classification |       |
|                  | 0 to 100                                   | 1%                             | 0               | Immediately  | Tuning         |       |
| Pn124<br>(2124h) | Friction Compensation Frequency Correction |                                |                 | Speed        | Position       |       |
|                  | Setting Range                              | Setting Unit                   | Default Setting | When Enabled | Classification |       |
|                  | -10,000 to 10,000                          | 0.1 Hz                         | 0               | Immediately  | Tuning         |       |
| Pn125<br>(2125h) | Friction Compensation Gain Correction      |                                |                 | Speed        | Position       |       |
|                  | Setting Range                              | Setting Unit                   | Default Setting | When Enabled | Classification |       |
|                  | 1 to 1,000                                 | 1%                             | 100             | Immediately  | Tuning         |       |

### Operating Procedure for Friction Compensation

Use the following procedure to perform friction compensation.

#### CAUTION

- Before you execute friction compensation, set the moment of inertia ratio (Pn103) as accurately as possible. If the setting greatly differs from the actual moment of inertia, vibration may occur.

| Step | Operation   |
|------|---|
| 1    | <p>Set the following parameters related to friction compensation to their default settings.</p> <p>Friction compensation gain (Pn121): 100<br/>           Second friction compensation gain (Pn122): 100<br/>           Friction compensation coefficient (Pn123): 0<br/>           Friction compensation frequency correction (Pn124): 0<br/>           Friction compensation gain correction (Pn125): 100</p> <p>Note: Always use the default settings for the friction compensation frequency correction (Pn124) and friction compensation gain correction (Pn125).</p>  |
| 2    | <p>Gradually increase the friction compensation coefficient (Pn123) to check the effect of friction compensation.</p> <p>Note: Usually, set the friction compensation coefficient (Pn123) to 95% or less.<br/>           If the effect is insufficient, increase the friction compensation gain (Pn121) by 10% increments until vibration stops.</p> <p><b>Effect of Adjusted Parameters</b></p> <p>Pn121: Friction Compensation Gain and Pn122: Second Friction Compensation Gain<br/>           These parameters set the response to external disturbances. The higher the setting is, the better the response will be. If the machine has a resonance frequency, however, vibration may occur if the setting is too high.</p> <p>Pn123: Friction Compensation Coefficient<br/>           This parameter sets the effect of friction compensation. The higher the setting is, the more effective friction compensation will be. If the setting is too high, however, vibration will occur more easily. Usually, set the value to 95% or less.</p> |
| 3    | <p><b>Effect of Adjustments</b></p> <p>The following graphs show the response with and without adjustment.</p> <p>Before Friction Compensation      After Friction Compensation</p>   |

## 9.12.3 Gravity Compensation

When the Servomotor is used with a vertical axis, gravity compensation prevents the moving part from falling due to the machine's own weight when the brake is released.

SERVOPACKs with software version 0024 or higher support gravity compensation.

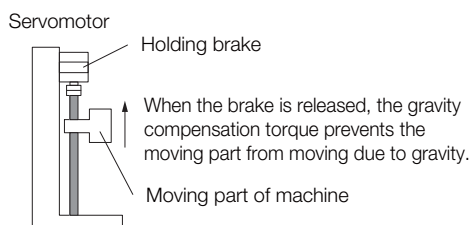

A timing chart for when the moving part is raised then lowered is provided below.

Refer to the following section for details on brake operation timing.

6.11.1 Brake Operating Sequence on page 6-31

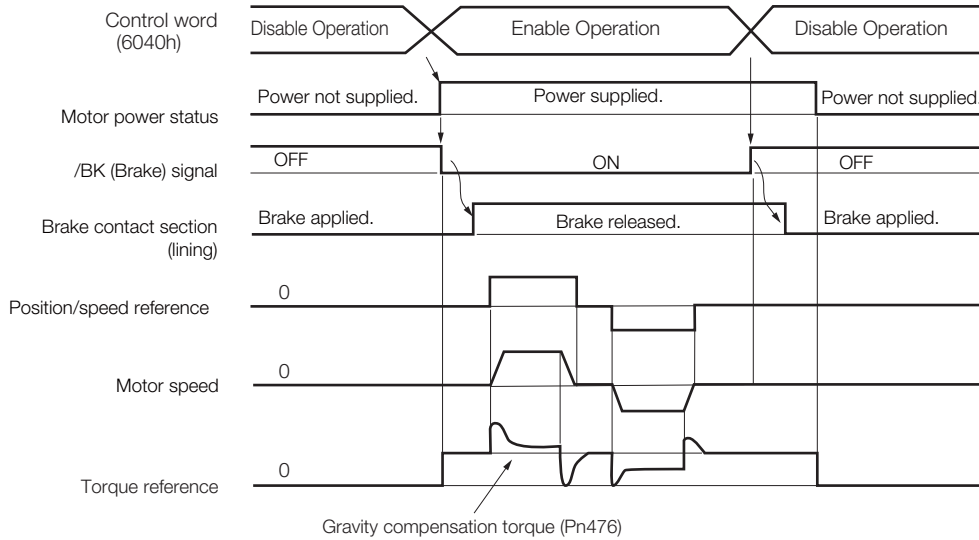

### Required Parameter Settings

The following parameter settings are required to use gravity compensation.

| Parameter        |                             | Description                   | When Enabled    | Classification |                |        |
|------------------|-----------------------------|-------------------------------|-----------------|----------------|----------------|--------|
| Pn475<br>(2475h) | n.□□□0<br>(default setting) | Disable gravity compensation. | After restart   | Setup          |                |        |
|                  | n.□□□1                      | Enable gravity compensation.  |                 |                |                |        |
| Pn476<br>(2476h) | Gravity Compensation Torque |                               |                 | Speed          | Position       | Torque |
|                  | Setting Range               | Setting Unit                  | Default Setting | When Enabled   | Classification |        |
|                  | -1,000 to 1,000             | 0.1%                          | 0               | Immediately    | Tuning         |        |

### Operating Procedure for Gravity Compensation

Use the following procedure to perform gravity compensation.

1. Set Pn475 to n.□□□1 (Enable gravity compensation).
2. To enable changes to the settings, turn the power supply to the SERVOPACK OFF and ON again.
3. Use SigmaWin+ or an analog monitor to find the torque reference value when the motor is stopped with the servo ON.
4. Set the torque reference value found in step 3 in Pn476 (Gravity Compensation Torque).
5. Turn the servo ON and OFF a few times and fine-tune Pn476 so that the moving part of the machine does not fall.

## 9.12.4 Current Control Mode Selection

Current control mode selection reduces high-frequency noise while the Servomotor is being stopped.

| Parameter        |                              | Meaning                                 | When Enabled  | Classification |
|------------------|------------------------------|---|---------------|----------------|
| Pn009<br>(2009h) | n. □□0□                      | Use current control mode 1.             | After restart | Tuning         |
|                  | n. □□1□<br>(default setting) | Use current control mode 2 (low noise). |               |                |
|                  | n. □□2□                      | Reserved parameter (Do not change.)     |               |                |





If current control mode 2 is selected, the load ratio may increase while the Servomotor is being stopped.

## 9.12.5 Current Gain Level Setting

You can set the current gain level to reduce noise by adjusting the parameter for current control inside the SERVOPACK according to the speed loop gain (Pn100). The noise level can be reduced by decreasing the current gain level (Pn13D) from its default setting of 2,000% (disabled). However, if the setting is decreased, the level of noise will be lowered, but the response characteristic of the SERVOPACK will also be reduced. Adjust the current gain level within the range that maintains the SERVOPACK response characteristic.

| Pn13D<br>(213Dh) | Current Gain Level |              |                 |              | Speed          | Position |
|------------------|--------------------|--------------|-----------------|--------------|----------------|----------|
|                  | Setting Range      | Setting Unit | Default Setting | When Enabled | Classification |          |
|                  | 100 to 2,000       | 1%           | 2,000           | Immediately  | Tuning         |          |



If the current gain level is changed, the response characteristic of the speed loop will also change. Servo tuning must therefore be performed again.

## 9.12.6 Speed Detection Method Selection

You can use the speed detection method selection to ensure smooth Servomotor speed changes during operation. To ensure smooth motor speed changes during operation, set Pn009 to n.□1□□ (Use speed detection 2).

With a Linear Servomotor, you can reduce the noise level of the running motor when the linear encoder scale pitch is large.

|                  | Parameter                    | Meaning                | When Enabled  | Classification |
|------------------|------------------------------|------------------------|---------------|----------------|
| Pn009<br>(2009h) | n. □0□□<br>(default setting) | Use speed detection 1. | After restart | Tuning         |
|                  | n. □1□□                      | Use speed detection 2. |               |                |



If the speed detection method is changed, the response characteristic of the speed loop will also change. Servo tuning must therefore be performed again.

## 9.12.7 Speed Feedback Filter

You can set a first order lag filter for the speed feedback in the speed loop. This ensures smooth changes in the feedback speed to reduce vibration. If a large value is set, it will increase the delay and make response slower.

| Pn308<br>(2308h) | Speed Feedback Filter Time Constant   |              |                 |              | Speed          | Position |
|------------------|---------------------------------------|--------------|-----------------|--------------|----------------|----------|
|                  | Setting Range                         | Setting Unit | Default Setting | When Enabled | Classification |          |
|                  | 0 to 65,535<br>(0.00 ms to 655.35 ms) | 0.01 ms      | 0<br>(0.00 ms)  | Immediately  | Setup          |          |

## 9.12.8 Backlash Compensation

### Outline

If you drive a machine that has backlash, there will be deviation between the travel distance in the position reference that is managed by the host controller and the travel distance of the actual machine. Use backlash compensation to add the backlash compensation value to the position reference and use the result to drive the Servomotor. This will ensure that the travel distance of the actual machine will be the same as the travel distance in the host controller.

- Note: 1. Backlash compensation can be used only with a Rotary Servomotor.  
 2. Backlash compensation can be used only for position control.

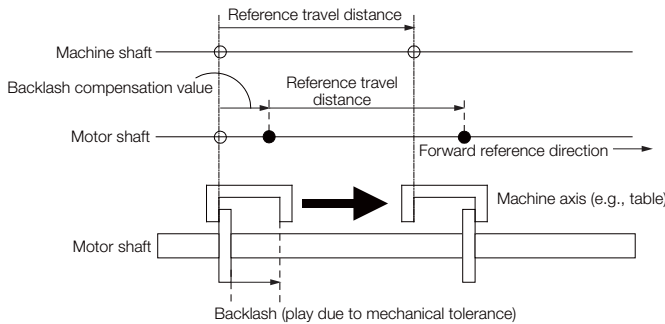

### Related Parameters

Set the following parameters to use backlash compensation.

#### ◆ Backlash Compensation Direction

Set the direction in which to apply backlash compensation.

| Parameter     | Meaning                   | When Enabled  | Classification |
|---------------|---------------------------|---------------|----------------|
| Pn230 (2230h) | n. □□□0 (default setting) | After restart | Setup          |
|               | n. □□□1                   |               |                |

#### ◆ Backlash Compensation Value

Set the amount of backlash compensation to add to the position reference. The amount is set in increments of 0.1 reference unit. However, when the amount is converted to encoder pulses, it is rounded off at the decimal point.

**Example** When Pn231 = 6553.6 [reference units] and position reference unit (Numerator/Denominator) = 1/1:  
 $6,553.6 \times 1 = 6,553.6$  [pulses]  
 ⇒ The backlash compensation will be 6,553 encoder pulses.

| Pn231 (2231h) | Backlash Compensation <span style="float: right;">[Position]</span> |                     |                 |              |                |
|---------------|---|---------------------|-----------------|--------------|----------------|
|               | Setting Range   | Setting Unit        | Default Setting | When Enabled | Classification |
|               | -500,000 to 500,000   | 0.1 reference units | 0               | Immediately  | Setup          |



Important

- The backlash compensation value is restricted by the following formula. Backlash compensation is not performed if this condition is not met.

$$Pn231 \leq \frac{\text{Denominator}}{\text{Numerator}} \times \frac{Pn210}{Pn20E} \times \frac{\text{Maximum motor speed [min}^{-1}\text{]}}{60} \times \text{Encoder resolution}^* \times 0.00025$$

\*Refer to the following section for the encoder resolution.

6.14 Setting Unit Systems on page 6-41

Example:

Denominator = 1, Numerator = 1, Maximum motor speed = 6,000 [min<sup>-1</sup>], and Encoder resolution = 16,777,216 (24 bits)

$1/1 \times 1/16 \times 6,000/60 \times 16,777,216 \times 0.00025 = 26,214.4$  [reference units]

⇒ The backlash compensation will be limited to 26,214.4 reference units.

- Do not exceed the upper limit of the backlash compensation value. You can check the upper limit on the operation monitor of the SigmaWin+.

## ◆ Backlash Compensation Time Constant

You can set a time constant for a first order lag filter for the backlash compensation value (Pn231) that is added to the position reference.

If you set Pn233 (Backlash Compensation Time Constant) to 0, the first order lag filter is disabled.

| Pn233<br>(2233h) | Backlash Compensation Time Constant |              |                 |              |                |
|------------------|-------------------------------------|--------------|-----------------|--------------|----------------|
|                  | Setting Range                       | Setting Unit | Default Setting | When Enabled | Classification |
|                  | 0 to 65,535                         | 0.01 ms      | 0               | Immediately  | Setup          |

Note: Changes to the settings are applied when there is no reference pulse input and the Servomotor is stopped.  
The current operation is not affected if the setting is changed during motor operation.

## Related Monitoring

You can monitor the following values on the operation monitor of the SigmaWin+.

| Displayed Value                           | Setting Unit        |
|---|---------------------|
| Current Backlash Compensation Value       | 0.1 reference units |
| Backlash Compensation Value Setting Limit | 0.1 reference units |

## Compensation Operation

This section describes the operation that is performed for backlash compensation.

Note: The following figures are for when backlash compensation is applied to references in the forward direction (Pn230 = n.□□□0). The following monitor information is provided in the figures: *target position* (607Ah) (target position in the reference coordinate system), *position demand value* (6062h) (reference position in the reference coordinate system), and *position actual value* (6064h) (feedback position in the machine coordinate system). The monitor information includes the feedback position in machine coordinate system (*position actual value*) and other feedback information. The backlash compensation value is subtracted from the feedback positions in the monitor information, so it is not necessary for the host controller to consider the backlash compensation value.

◆ Operation When the Servo Is ON

The backlash compensation value (Pn231) is added in the backlash compensation direction when the servo is ON (i.e., while power is supplied to the motor) and a reference is input in the same direction as the backlash compensation direction (Pn230.0 = n.□□□X). When there is a reference input in the direction opposite to the backlash compensation direction, the backlash compensation value is not added (i.e., backlash compensation is not performed).

The relationship between *position actual value* (6064h) and the motor shaft position is as follows:

- If a reference is input in the compensation direction: Position actual value (6064h) = Motor shaft position - Pn231
- If a reference is input in the direction opposite to the compensation direction: Position actual value (6064h) = Motor shaft position

The following figure shows driving the Servomotor in the forward direction from Target Position 0 (*target position*: 607Ah) to Target Position 1 and then to Target Position 2, and then returning from Target Position 2 to Target Position 1 and then to Target Position 0.

Backlash compensation is applied when moving from Target Position 0 to Target Position 1, but not when moving from Target Position 2 to Target Position 1.

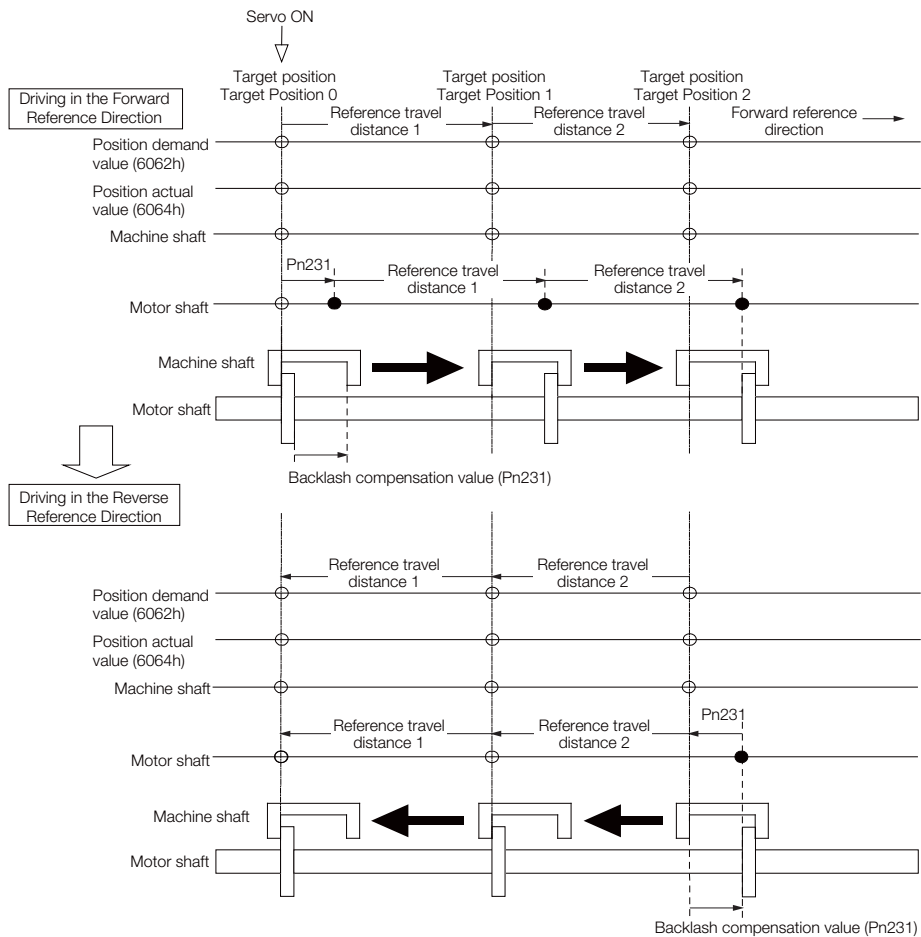

### ◆ Operation When the Servo Is OFF

Backlash compensation is not applied when the servo is OFF (i.e., when power is not supplied to motor). Therefore, the reference position (*position demand value* (6062h)) is moved by only the backlash compensation value.

The relationship between *position actual value* (6064h) and the motor shaft position is as follows:

- When servo is OFF: Position actual value (6064h) = Servomotor shaft position

The following figure shows what happens when the servo is turned OFF after driving the Servomotor in the forward direction from target position Target Position 0 to Target Position 1. Backlash compensation is not applied when the servo is OFF. (The SERVOPACK manages the position data so that *position actual value* (6064h) and *position demand value* (6062h) are the same.)

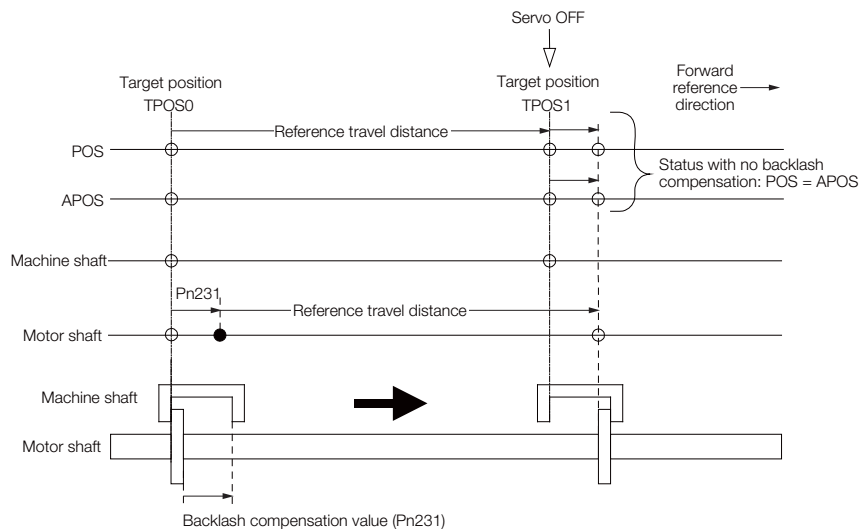

### ◆ Operation When There Is Overtravel

When there is overtravel (i.e., when driving is prohibited due to an overtravel signal or software limit), the operation is the same as for when the servo is OFF (◆ *Operation When the Servo Is OFF* on page 9-75), i.e., backlash compensation is not applied.

### ◆ Operation When Control Is Changed

Backlash compensation is performed only for position control.

Backlash compensation is not applied when position control is changed to any other control method.

Backlash compensation is applied in the same way as when the servo is ON (◆ *Operation When the Servo Is ON* on page 9-74) if any other control method is changed to position control.

## Related Monitoring

You can monitor the following values on the operation monitor of the SigmaWin+.

| Displayed Value               | Unit              | Specification   |
|-------------------------------|-------------------|---|
| Input Reference Pulse Speed   | min <sup>-1</sup> | Displays the input reference pulse speed before backlash compensation.                  |
| Position Deviation            | Reference units   | Displays the position deviation for the position reference after backlash compensation. |
| Input Reference Pulse Counter | Reference units   | Displays the input reference pulse counter before backlash compensation.                |
| Feedback Pulse Counter        | Encoder pulses    | Displays the number of pulses from the actually driven motor encoder.                   |
| Feedback Pulse Counter        | Reference units   | Displays the number of pulses from the actually driven encoder in reference units.      |

◆ Related Monitoring Diagrams

The following symbols are used in the related monitoring diagrams.

- [A]: Analog monitor
- [E]: EtherCAT monitor Information
- [U]: Monitor mode (Un monitor)
- [O]: Output signal
- [T]: Trace data

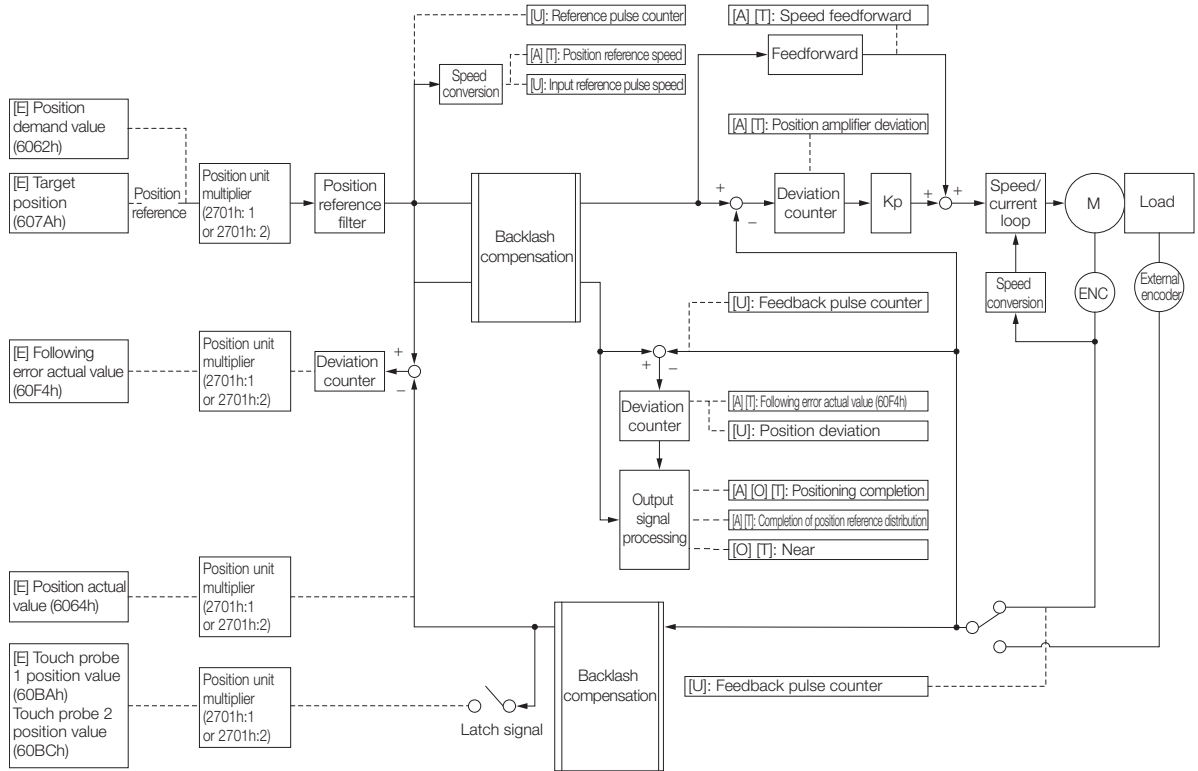

## 9.13 Manual Tuning

This section describes manual tuning.

### 9.13.1 Tuning the Servo Gains

#### Servo Gains

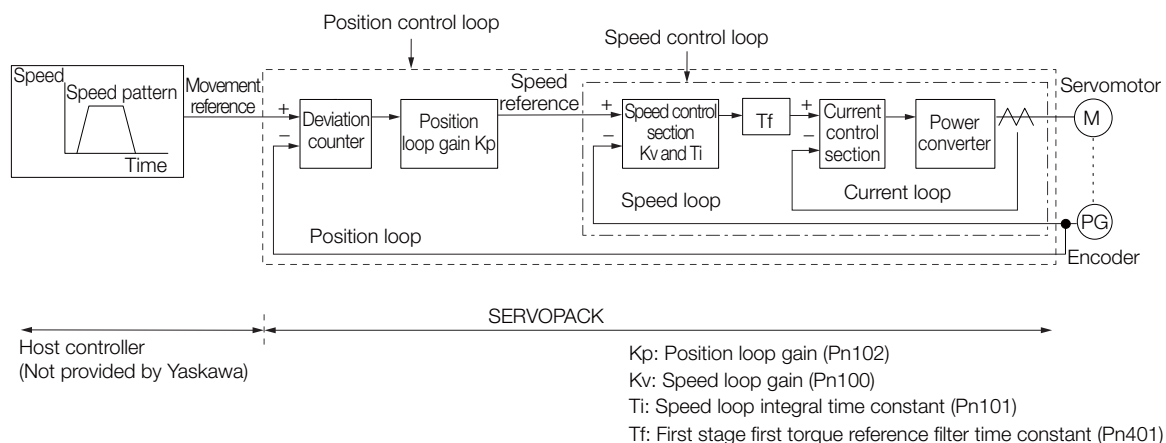

In order to manually tune the servo gains, you must understand the configuration and characteristic of the SERVOPACK and adjust the servo gains individually. In most cases, if you greatly change any one parameter, you must adjust the other parameters again. To check the response characteristic, you must prepare a measuring instrument to monitor the output waveforms from the analog monitor.

The SERVOPACK has three feedback systems (the position loop, speed loop, and current loop), and the response characteristic must be increased more with the inner loops. If this relationship is not maintained, the response characteristic will suffer and vibration will occur more easily.

A sufficient response characteristic is ensured for the current loop. There is never a need for it to be adjusted by the user.

#### Outline

You can use manual tuning to set the servo gains in the SERVOPACK to increase the response characteristic of the SERVOPACK. For example, you can reduce the positioning time for position control.

Use manual tuning in the following cases.

- When tuning with autotuning without a host reference or autotuning with a host reference does not achieve the desired results
- When you want to increase the servo gains higher than the gains that resulted from autotuning without a host reference or autotuning with a host reference
- When you want to determine the servo gains and moment of inertia ratio yourself

You start manual tuning either from the default parameter settings or from the gain settings that resulted from autotuning without a host reference or autotuning with a host reference.

## Applicable Tools

You can monitor the servo gains with the SigmaWin+ or with the analog monitor.

## Precautions

Vibration may occur while you are tuning the servo gains. We recommend that you enable vibration alarms (Pn310 = n.□□□2) to detect vibration. Refer to the following section for information on vibration detection.

 7.10 *Initializing the Vibration Detection Level on page 7-37*

Vibration alarms are not detected for all vibration. Also, an emergency stop method is necessary to stop the machine safely when an alarm occurs. You must provide an emergency stop device and activate it immediately whenever vibration occurs.

## Tuning Procedure Example (for Position Control or Speed Control)

| Step | Description   |
|------|---|
| 1    | Adjust the first stage first torque reference filter time constant (Pn401) so that vibration does not occur.  |
| 2    | Increase the position loop gain (Pn100) and reduce the speed loop integral time constant (Pn101) as far as possible within the range that does not cause machine vibration. |
| 3    | Repeat steps 1 and 2 and return the settings about 10% to 20% from the values that you set.   |
| 4    | For position control, increase the position loop gain (Pn102) within the range that does not cause vibration.   |

### Information

If you greatly change any one servo gain parameter, you must adjust the other parameters again. Do not increase the setting of just one parameter. As a guideline, adjust the settings of the servo gains by approximately 5% each. As a rule, change the servo parameters in the following order.

- To Increase the Response Speed
  1. Reduce the torque reference filter time constant.
  2. Increase the speed loop gain.
  3. Decrease the speed loop integral time constant.
  4. Increase the position loop gain.
- To Reduce Response Speed and to Stop Vibration and Overshooting
  1. Reduce the position loop gain.
  2. Increase the speed loop integral time constant.
  3. Decrease the speed loop gain.
  4. Increase the torque filter time constant.

## Adjusted Servo Gains

You can set the following gains to adjust the response characteristic of the SERVOPACK.

- Pn100: Speed Loop Gain
- Pn101: Speed Loop Integral Time Constant
- Pn102: Position Loop Gain
- Pn401: First Stage First Torque Reference Filter Time Constant

### ◆ Position Loop Gain

The position loop gain determines the response characteristic of the position loop in the SERVOPACK. If you can increase the setting of the position loop gain, the response characteristic will improve and the positioning time will be shortened. However, you normally cannot increase the position loop gain higher than the inherent vibration frequency of the machine system. Therefore, to increase the setting of the position loop gain, you must increase the rigidity of the machine to increase the inherent vibration frequency of the machine.



| Pn102<br>(2102h) | Position Loop Gain |              |                 |              |                |
|------------------|--------------------|--------------|-----------------|--------------|----------------|
|                  | Setting Range      | Setting Unit | Default Setting | When Enabled | Classification |
|                  | 10 to 20,000       | 0.1/s        | 400             | Immediately  | Tuning         |

**Information** For machines for which a high position loop gain (Pn102) cannot be set, overflow alarms can occur during high-speed operation. If that is the case, you can increase the setting of the following parameter to increase the level for alarm detection. Use the following condition as a guideline for determining the setting.

$$Pn520 \geq \frac{\text{Maximum feed speed [reference units/s]}}{Pn102 \div 10 (1/s)} \times 2.0$$

If you use a position reference filter, transient deviation will increase due to the filter time constant. When you make the setting, consider deviation accumulation that may result from the filter.

| Pn520<br>(2520h) | Position Deviation Overflow Alarm Level |                  |                 |              |                |
|------------------|---|------------------|-----------------|--------------|----------------|
|                  | Setting Range                           | Setting Unit     | Default Setting | When Enabled | Classification |
|                  | 1 to 1,073,741,823                      | 1 reference unit | 5,242,880       | Immediately  | Setup          |

## ◆ Speed Loop Gain

This parameter determines the response characteristic of the speed loop. If the response characteristic of the speed loop is low, it becomes a delay factor for the position loop located outside of the speed loop. This will result in overshooting and vibration in the speed reference. Therefore, setting the speed loop gain as high as possible within the range that will not cause the machine system to vibrate will produce a stable servo system with a good response characteristic.

| Pn100<br>(2100h) | Speed Loop Gain |              |                 |              |                |
|------------------|-----------------|--------------|-----------------|--------------|----------------|
|                  | Setting Range   | Setting Unit | Default Setting | When Enabled | Classification |
|                  | 10 to 20,000    | 0.1 Hz       | 400             | Immediately  | Tuning         |

$$\text{Setting of Pn103} = \frac{\text{Load moment of inertia at motor shaft } (J_L)}{\text{Servomotor moment of inertia } (L_M)} \times 100(\%)$$

The default setting of Pn103 (Moment of Inertia Ratio) is 100. Before you tune the servo, calculate the moment of inertia ratio with the above formula and set Pn103 to the calculation result.

| Pn103<br>(2103h) | Moment of Inertia Ratio |              |                 |              |                |
|------------------|-------------------------|--------------|-----------------|--------------|----------------|
|                  | Setting Range           | Setting Unit | Default Setting | When Enabled | Classification |
|                  | 0 to 20,000             | 1%           | 100             | Immediately  | Tuning         |

## ◆ Speed Loop Integral Time Constant

To enable response to even small inputs, the speed loop has an integral element. The integral element becomes a delay factor in the servo system. If the time constant is set too high, overshooting will occur, positioning settling time will increase, and the response characteristic will suffer.

| Pn101<br>(2101h) | Speed Loop Integral Time Constant |              |                 |              |                |
|------------------|-----------------------------------|--------------|-----------------|--------------|----------------|
|                  | Setting Range                     | Setting Unit | Default Setting | When Enabled | Classification |
|                  | 15 to 51,200                      | 0.01 ms      | 2,000           | Immediately  | Tuning         |

### ◆ Torque Reference Filter

As shown in the following diagram, the torque reference filter contains a first order lag filter and notch filters arranged in series, and each filter operates independently.

The notch filters can be enabled and disabled with Pn408 = n.□X□X and Pn416 = n.□XXX.

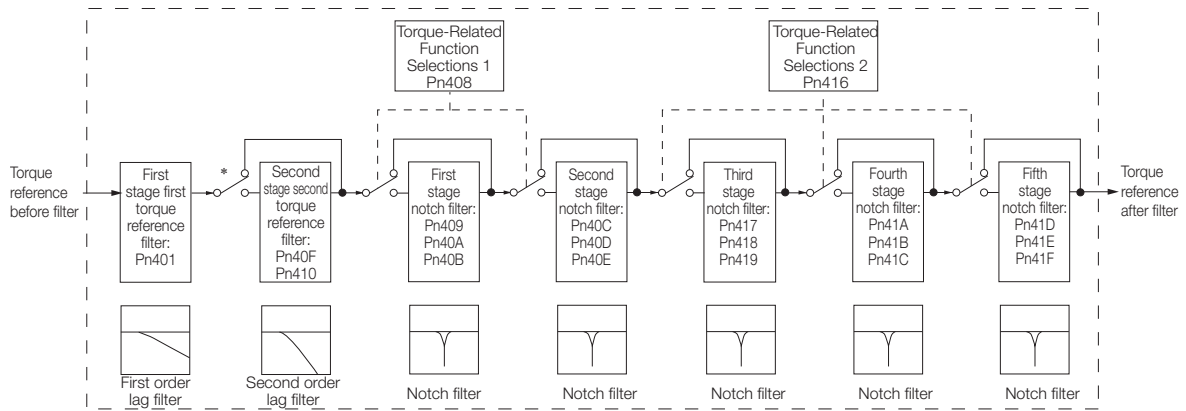

\* The second stage second torque reference filter is disabled when Pn40F is set to 5,000 (default setting) and it is enabled when Pn40F is set to a value lower than 5,000.

### ■ Torque Reference Filter

If you suspect that machine vibration is being caused by the Servo Drive, try adjusting the torque reference filter time constant. This may stop the vibration. The lower the value, the better the control response characteristic will be, but there may be a limit depending on the machine conditions.

|                  |   |              |                 |              |                |        |
|------------------|---|--------------|-----------------|--------------|----------------|--------|
| Pn401<br>(2401h) | First Stage First Torque Reference Filter Time Constant |              |                 | Speed        | Position       | Torque |
|                  | Setting Range   | Setting Unit | Default Setting | When Enabled | Classification |        |
|                  | 0 to 65,535   | 0.01 ms      | 100             | Immediately  | Tuning         |        |
| Pn40F<br>(240Fh) | Second Stage Second Torque Reference Filter Frequency   |              |                 | Speed        | Position       | Torque |
|                  | Setting Range   | Setting Unit | Default Setting | When Enabled | Classification |        |
|                  | 100 to 5,000  | 1 Hz         | 5,000*          | Immediately  | Tuning         |        |
| Pn410<br>(2410h) | Second Stage Second Torque Reference Filter Q Value     |              |                 | Speed        | Position       | Torque |
|                  | Setting Range   | Setting Unit | Default Setting | When Enabled | Classification |        |
|                  | 50 to 100   | 0.01         | 50              | Immediately  | Tuning         |        |

\* The filter is disabled if you set the parameter to 5,000.

### ■ Notch Filters

The notch filter can eliminate specific frequency elements generated by the vibration of sources such as resonance of the shaft of a ball screw.

The notch filter puts a notch in the gain curve at the specific vibration frequency (called the notch frequency). The frequency components near the notch frequency can be reduced or removed with a notch filter.

Notch filters are set with three parameters for the notch filter frequency, notch filter Q value, and notch filter depth. This section describes the notch filter Q value and notch filter depth.

#### • Notch filter Q Value

The setting of the notch filter Q value determines the width of the frequencies that are filtered for the notch filter frequency. The width of the notch changes with the notch filter Q value. The larger the notch filter Q value is, the steeper the notch is and the narrower the width of frequencies that are filtered is.

The notch filter frequency characteristics for different notch filter Q values are shown below.

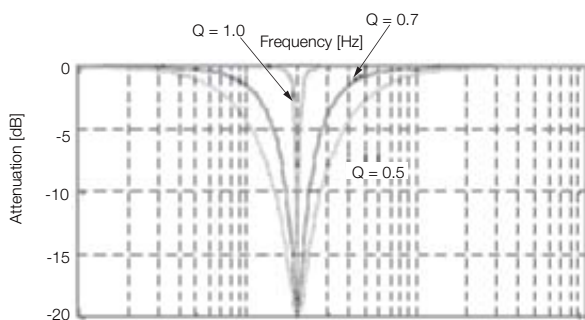

Note: The above notch filter frequency characteristics are based on calculated values and may be different from actual characteristics.

• Notch Filter Depth

The setting of the notch filter depth determines the depth of the frequencies that are filtered for the notch filter frequency. The depth of the notch changes with the notch filter depth. The smaller the notch filter depth is, the deeper the notch is, increasing the effect of vibration suppression. However, if the value is too small, vibration can actually increase.

The notch filter is disabled if the notch filter depth, d, is set to 1.0 (i.e., if Pn419 is set to 1,000).

The notch filter frequency characteristics for different notch filter depths are shown below.

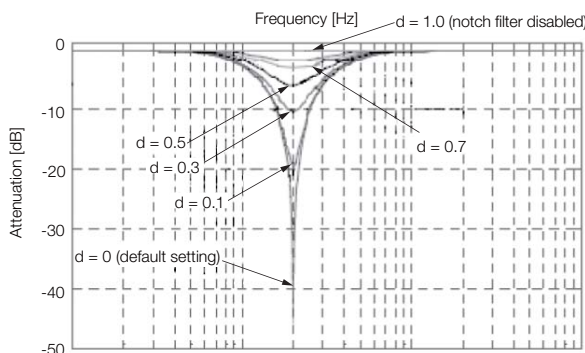

Note: The above notch filter frequency characteristics are based on calculated values and may be different from actual characteristics.

You can enable or disable the notch filter with Pn408.

| Parameter     | Meaning                  | When Enabled                       | Classification       |
|---------------|--------------------------|------------------------------------|----------------------|
| Pn408 (2408h) | n.□□□0 (default setting) | Disable first stage notch filter.  | Immediately<br>Setup |
|               | n.□□□1                   | Enable first stage notch filter.   |                      |
|               | n.□0□□ (default setting) | Disable second stage notch filter. |                      |
|               | n.□1□□                   | Enable second stage notch filter.  |                      |
| Pn416 (2416h) | n.□□□0 (default setting) | Disable third stage notch filter.  |                      |
|               | n.□□□1                   | Enable third stage notch filter.   |                      |
|               | n.□□0□ (default setting) | Disable fourth stage notch filter. |                      |
|               | n.□□1□                   | Enable fourth stage notch filter.  |                      |
|               | n.□0□□ (default setting) | Disable fifth stage notch filter.  |                      |
|               | n.□1□□                   | Enable fifth stage notch filter.   |                      |

Set the machine vibration frequencies in the notch filter parameters.

|                  |                                     |              |                 |              |                |          |        |
|------------------|-------------------------------------|--------------|-----------------|--------------|----------------|----------|--------|
| Pn409<br>(2409h) | First Stage Notch Filter Frequency  |              |                 |              | Speed          | Position | Torque |
|                  | Setting Range                       | Setting Unit | Default Setting | When Enabled | Classification |          |        |
|                  | 50 to 5,000                         | 1 Hz         | 5,000           | Immediately  | Tuning         |          |        |
| Pn40A<br>(240Ah) | First Stage Notch Filter Q Value    |              |                 |              | Speed          | Position | Torque |
|                  | Setting Range                       | Setting Unit | Default Setting | When Enabled | Classification |          |        |
|                  | 50 to 1,000                         | 0.01         | 70              | Immediately  | Tuning         |          |        |
| Pn40B<br>(240Bh) | First Stage Notch Filter Depth      |              |                 |              | Speed          | Position | Torque |
|                  | Setting Range                       | Setting Unit | Default Setting | When Enabled | Classification |          |        |
|                  | 0 to 1,000                          | 0.001        | 0               | Immediately  | Tuning         |          |        |
| Pn40C<br>(240Ch) | Second Stage Notch Filter Frequency |              |                 |              | Speed          | Position | Torque |
|                  | Setting Range                       | Setting Unit | Default Setting | When Enabled | Classification |          |        |
|                  | 50 to 5,000                         | 1 Hz         | 5,000           | Immediately  | Tuning         |          |        |
| Pn40D<br>(240Dh) | Second Stage Notch Filter Q Value   |              |                 |              | Speed          | Position | Torque |
|                  | Setting Range                       | Setting Unit | Default Setting | When Enabled | Classification |          |        |
|                  | 50 to 1,000                         | 0.01         | 70              | Immediately  | Tuning         |          |        |
| Pn40E<br>(240Eh) | Second Stage Notch Filter Depth     |              |                 |              | Speed          | Position | Torque |
|                  | Setting Range                       | Setting Unit | Default Setting | When Enabled | Classification |          |        |
|                  | 0 to 1,000                          | 0.001        | 0               | Immediately  | Tuning         |          |        |
| Pn417<br>(2417h) | Third Stage Notch Filter Frequency  |              |                 |              | Speed          | Position | Torque |
|                  | Setting Range                       | Setting Unit | Default Setting | When Enabled | Classification |          |        |
|                  | 50 to 5,000                         | 1 Hz         | 5,000           | Immediately  | Tuning         |          |        |
| Pn418<br>(2418h) | Third Stage Notch Filter Q Value    |              |                 |              | Speed          | Position | Torque |
|                  | Setting Range                       | Setting Unit | Default Setting | When Enabled | Classification |          |        |
|                  | 50 to 1,000                         | 0.01         | 70              | Immediately  | Tuning         |          |        |
| Pn419<br>(2419h) | Third Stage Notch Filter Depth      |              |                 |              | Speed          | Position | Torque |
|                  | Setting Range                       | Setting Unit | Default Setting | When Enabled | Classification |          |        |
|                  | 0 to 1,000                          | 0.001        | 0               | Immediately  | Tuning         |          |        |
| Pn41A<br>(241Ah) | Fourth Stage Notch Filter Frequency |              |                 |              | Speed          | Position | Torque |
|                  | Setting Range                       | Setting Unit | Default Setting | When Enabled | Classification |          |        |
|                  | 50 to 5,000                         | 1 Hz         | 5,000           | Immediately  | Tuning         |          |        |
| Pn41B<br>(241Bh) | Fourth Stage Notch Filter Q Value   |              |                 |              | Speed          | Position | Torque |
|                  | Setting Range                       | Setting Unit | Default Setting | When Enabled | Classification |          |        |
|                  | 50 to 1,000                         | 0.01         | 70              | Immediately  | Tuning         |          |        |
| Pn41C<br>(241Ch) | Fourth Stage Notch Filter Depth     |              |                 |              | Speed          | Position | Torque |
|                  | Setting Range                       | Setting Unit | Default Setting | When Enabled | Classification |          |        |
|                  | 0 to 1,000                          | 0.001        | 0               | Immediately  | Tuning         |          |        |
| Pn41D<br>(241Dh) | Fifth Stage Notch Filter Frequency  |              |                 |              | Speed          | Position | Torque |
|                  | Setting Range                       | Setting Unit | Default Setting | When Enabled | Classification |          |        |
|                  | 50 to 5,000                         | 1 Hz         | 5,000           | Immediately  | Tuning         |          |        |
| Pn41E<br>(241Eh) | Fifth Stage Notch Filter Q Value    |              |                 |              | Speed          | Position | Torque |
|                  | Setting Range                       | Setting Unit | Default Setting | When Enabled | Classification |          |        |
|                  | 50 to 1,000                         | 0.01         | 70              | Immediately  | Tuning         |          |        |
| Pn41F<br>(241Fh) | Fifth Stage Notch Filter Depth      |              |                 |              | Speed          | Position | Torque |
|                  | Setting Range                       | Setting Unit | Default Setting | When Enabled | Classification |          |        |
|                  | 0 to 1,000                          | 0.001        | 0               | Immediately  | Tuning         |          |        |



**Important**

- Do not set notch filter frequencies (Pn409, Pn40C, Pn417, Pn41A, and Pn41D) that are close to the speed loop's response frequency. Set a frequency that is at least four times the speed loop gain (Pn100). (However, Pn103 (Moment of Inertia Ratio) must be set to an appropriate value.) If the setting is not correct, vibration may occur and the machine may be damaged.
- Change the notch filter frequencies (Pn409, Pn40C, Pn417, Pn41A, and Pn41D) only while the Servomotor is stopped. Vibration may occur if a notch filter frequency is changed during operation.

## Guidelines for Manually Tuning Servo Gains

When you manually adjust the parameters, make sure that you completely understand the information in the product manual and use the following conditional expressions as guidelines. The appropriate values of the parameter settings are influenced by the machine specifications, so they cannot be determined universally. When you adjust the parameters, actually operate the machine and use the SigmaWin+ or analog monitor to monitor operating conditions. Even if the status is stable while the motor is stopped, an unstable condition may occur when an operation reference is input. Therefore, input operation references and adjust the servo gains as you operate the motor.

**Stable gain:** Settings that provide a good balance between parameters.

However, if the load moment of inertia is large and the machine system contains elements prone to vibration, you must sometimes use a setting that is somewhat higher to prevent the machine from vibrating.

**Critical gain:** Settings for which the parameters affect each other

Depending on the machine conditions, overshooting and vibration may occur and operation may not be stable. If the critical gain condition expressions are not met, operation will become more unstable, and there is a risk of abnormal motor shaft vibration and round-trip operation with a large amplitude. Always stay within the critical gain conditions.

If you use the torque reference filter, second torque reference filter, and notch filters together, the interference between the filters and the speed loop gain will be superimposed. Allow leeway in the adjustments.



Important

The following adjusted value guidelines require that the setting of Pn103 (Moment of Inertia Ratio) is correctly set for the actual machine.

### ◆ When Pn10B = n.□□0□ (PI Control )

Guidelines are given below for gain settings 1.

The same guidelines apply to gain settings 2 (Pn104, Pn105, Pn106, and Pn412).

- Speed Loop Gain (Pn100 [Hz]) and Position Loop Gain (Pn102 [1/s])
  - Stable gain:  $Pn102 [1/s] \leq 2\pi \times Pn100/4 [Hz]$
  - Critical gain:  $Pn102 [1/s] < 2\pi \times Pn100 [Hz]$
- Speed Loop Gain (Pn100 [Hz]) and Speed Loop Integral Time Constant (Pn101 [ms])
  - Stable gain:  $Pn101 [ms] \geq 4,000/(2\pi \times Pn100 [Hz])$
  - Critical gain:  $Pn101 [ms] > 1,000/(2\pi \times Pn100 [Hz])$
- Speed Loop Gain (Pn100 [Hz]) and First Stage First Torque Reference Filter Time Constant (Pn401 [ms])
  - Stable gain:  $Pn401 [ms] \leq 1,000/(2\pi \times Pn100 [Hz] \times 4)$
  - Critical gain:  $Pn401 [ms] < 1,000/(2\pi \times Pn100 [Hz] \times 1)$

- Speed Loop Gain (Pn100 [Hz]) and Second Stage Second Torque Reference Filter Frequency (Pn40F [Hz])  
Critical gain:  $Pn40F [Hz] > 4 \times Pn100 [Hz]$   
Note: Set the second stage second torque reference filter Q value (Pn410) to 0.70.
- Speed Loop Gain (Pn100 [Hz]) and First Stage Notch Filter Frequency (Pn409 [Hz]) (or Second Stage Notch Filter Frequency (Pn40C [Hz]))  
Critical gain:  $Pn409 [Hz] > 4 \times Pn100 [Hz]$
- Speed Loop Gain (Pn100 [Hz]) and Speed Feedback Filter Time Constant (Pn308 [ms])  
Stable gain:  $Pn308 [ms] \leq 1,000 / (2\pi \times Pn100 [Hz] \times 4)$   
Critical gain:  $Pn308 [ms] < 1,000 / (2\pi \times Pn100 [Hz] \times 1)$

### ◆ When Pn10B = n.□□1□ (I-P Control)

Guidelines are given below for gain settings 1.

The same guidelines apply to gain settings 2 (Pn104, Pn105, Pn106, and Pn412).

For I-P control, the relationships between the speed loop integral time constant, speed loop gain, and position loop gain are different from the relationships for PI control. The relationship between other servo gains is the same as for PI control.

- Speed Loop Gain (Pn100 [Hz]) and Speed Loop Integral Time Constant (Pn101 [ms])  
Stable gain:  $Pn100 [Hz] \geq 320 / Pn101 [ms]$
- Position Loop Gain (Pn102 [/s]) and Speed Loop Integral Time Constant (Pn101 [ms])  
Stable gain:  $Pn102 [/s] \leq 320 / Pn101 [ms]$

#### Information

#### Selecting the Speed Loop Control Method (PI Control or I-P Control)

Usually, I-P control is effective for high-speed positioning and high-speed, high-precision processing applications. With I-P control, you can use a lower position loop gain than for PI control to reduce the positioning time and reduce arc radius reduction. However, if you can use mode switching to change to proportional control to achieve the desired application, then using PI control would be the normal choice.

### ◆ Decimal Points in Parameter Settings

For the SGD7W SERVOPACKs, decimal places are given for the settings of parameters on the Digital Operator, Panel Operator, and in the manual. For example with Speed Loop Gain (Pn100), Pn100 = 40.0 is used to indicate a setting of 40.0 Hz. In the following adjusted value guidelines, the decimal places are also given.

#### Example

- Speed Loop Gain (Pn100 [Hz]) and Speed Loop Integral Time Constant (Pn101 [ms])  
Stable gain:  $Pn101 [ms] \geq 4,000 / (2\pi \times Pn100 [Hz])$ , therefore  
If Pn100 = 40.0 [Hz], then  $Pn101 = 4,000 / (2\pi \times 40.0) \approx 15.92 [ms]$ .

## Model Following Control

You can use model following control to improve response characteristic and shorten positioning time. You can use model following control only with position control.

Normally, the parameters that are used for model following control are automatically set along with the servo gains by executing autotuning or custom tuning. However, you must adjust them manually in the following cases.

- When the tuning results for autotuning or custom tuning are not acceptable
- When you want to increase the response characteristic higher than that achieved by the tuning results for autotuning or custom tuning
- When you want to determine the servo gains and model following control parameters yourself

The block diagram for model following control is provided below.

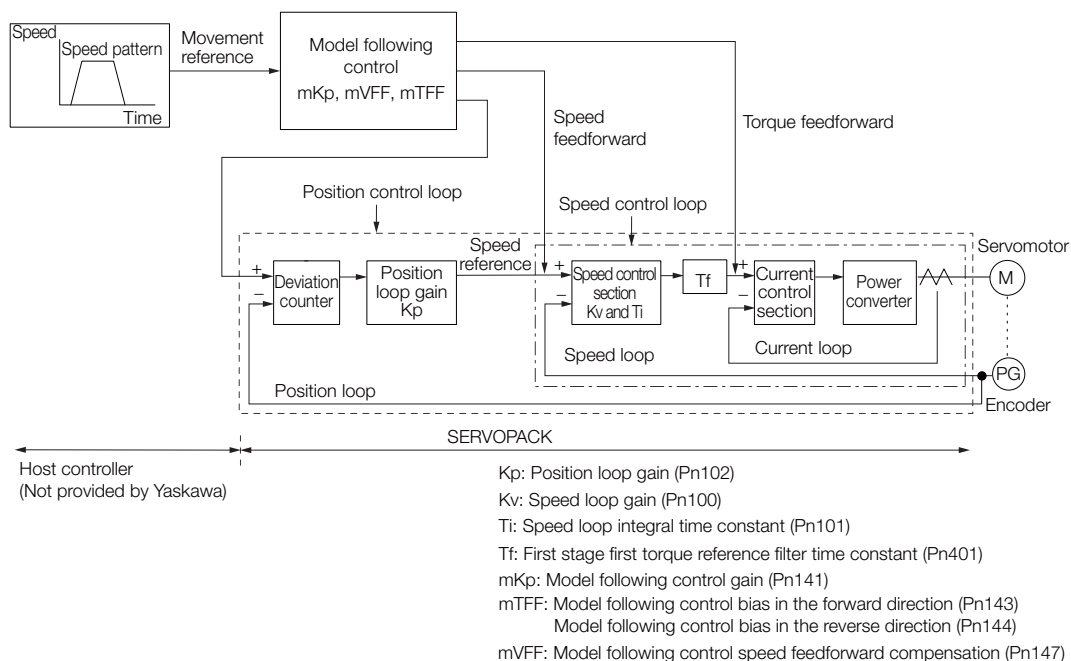

### ◆ Manual Tuning Procedure

Use the following tuning procedure for using model following control.

| Step | Description   |
|------|---|
| 1    | Friction compensation must also be used. Set the friction compensation parameters. Refer to the following section for the setting procedure.<br>📖 9.12.2 Friction Compensation on page 9-68   |
| 2    | Adjust the servo gains. Refer to the following section for an example procedure.<br>📖 Tuning Procedure Example (for Position Control or Speed Control) on page 9-78<br>Note: 1. Set the moment of inertia ratio (Pn103) as accurately as possible.<br>2. Refer to the guidelines for manually tuning the servo gains and set a stable gain for the position loop gain (Pn102).<br>📖 Guidelines for Manually Tuning Servo Gains on page 9-83 |
| 3    | Increase the model following control gain (Pn141) as much as possible within the range in which overshooting and vibration do not occur.  |
| 4    | If overshooting occurs or if the response is different for forward and reverse operation, fine-tune model following control with the following settings: model following control bias in the forward direction (Pn143), model following control bias in the reverse direction (Pn144), and model following control speed feedforward compensation (Pn147).  |

### ◆ Related Parameters

Next we will describe the following parameters that are used for model following control.

- Pn140 (Model Following Control-Related Selections)
- Pn141 (Model Following Control Gain)
- Pn143 (Model Following Control Bias in the Forward Direction)
- Pn144 (Model Following Control Bias in the Reverse Direction)
- Pn147 (Model Following Control Speed Feedforward Compensation)

#### ■ Model Following Control-Related Selections

Set Pn140 = n.□□□X to specify whether to use model following control.

If you use model following control with vibration suppression, set Pn140 to n.□□1□ or Pn140 = n.□□2□. When you also perform vibration suppression, adjust vibration suppression with custom tuning in advance.

Note: If you use vibration suppression (Pn140 = n.□□1□ or Pn140 = n.□□2□), always set Pn140 to n.□□□1 (Use model following control).

| Parameter        | Function                    | When Enabled  | Classification            |
|------------------|-----------------------------|---|---------------------------|
| Pn140<br>(2140h) | n.□□□0<br>(default setting) | Do not use model following control.                         | Immediately<br><br>Tuning |
|                  | n.□□□1                      | Use model following control.                                |                           |
|                  | n.□□□□<br>(default setting) | Do not perform vibration suppression.                       |                           |
|                  | n.□□1□                      | Perform vibration suppression for a specific frequency.     |                           |
|                  | n.□□2□                      | Perform vibration suppression for two specific frequencies. |                           |

■ Model Following Control Gain

The model following control gain determines the response characteristic of the servo system. If you increase the setting of the model following control gain, the response characteristic will improve and the positioning time will be shortened. The response characteristic of the servo system is determined by this parameter, and not by Pn102 (Position Loop Gain).

| Pn141<br>(2141h) | Model Following Control Gain |              |                 |              | Position       |
|------------------|------------------------------|--------------|-----------------|--------------|----------------|
|                  | Setting Range                | Setting Unit | Default Setting | When Enabled | Classification |
|                  | 10 to 20,000                 | 0.1/s        | 500             | Immediately  | Tuning         |

Information

For machines for which a high model following control gain cannot be set, the size of the position deviation in model following control will be determined by the setting of the model following control gain. For a machine with low rigidity, in which a high model following control gain cannot be set, position deviation overflow alarms may occur during high-speed operation. If that is the case, you can increase the setting of the following parameter to increase the level for alarm detection.

Use the following conditional expression for reference in determining the setting.

$$Pn\ 520 \geq \frac{\text{Maximum feed speed [reference units/s]}}{Pn\ 141/10 [1/s]} \times 2.0$$

| Pn520<br>(2520h) | Position Deviation Overflow Alarm Level |                  |                 |              | Position       |
|------------------|---|------------------|-----------------|--------------|----------------|
|                  | Setting Range                           | Setting Unit     | Default Setting | When Enabled | Classification |
|                  | 1 to 1,073,741,823                      | 1 reference unit | 5,242,880       | Immediately  | Setup          |

■ Model Following Control Bias in the Forward Direction and Model Following Control Bias in the Reverse Direction

If the response is different for forward and reverse operation, use the following parameters for fine-tuning.

If you decrease the settings, the response characteristic will be lowered but overshooting will be less likely to occur.

| Pn143<br>(2143h) | Model Following Control Bias in the Forward Direction |              |                 |              | Position       |
|------------------|---|--------------|-----------------|--------------|----------------|
|                  | Setting Range   | Setting Unit | Default Setting | When Enabled | Classification |
|                  | 0 to 10,000   | 0.1%         | 1,000           | Immediately  | Tuning         |

| Pn144<br>(2144h) | Model Following Control Bias in the Reverse Direction |              |                 |              | Position       |
|------------------|---|--------------|-----------------|--------------|----------------|
|                  | Setting Range   | Setting Unit | Default Setting | When Enabled | Classification |
|                  | 0 to 10,000   | 0.1%         | 1,000           | Immediately  | Tuning         |



■ Model Following Control Speed Feedforward Compensation

If overshooting occurs even after you adjust the model following control gain, model following control bias in the forward direction, and model following control bias in the reverse direction, you may be able to improve performance by setting the following parameter.

If you decrease the settings, the response characteristic will be lowered but overshooting will be less likely to occur.

| Pn147<br>(2147h) | Model Following Control Speed Feedforward Compensation |              |                 |              | Position       |
|------------------|--|--------------|-----------------|--------------|----------------|
|                  | Setting Range  | Setting Unit | Default Setting | When Enabled | Classification |
|                  | 0 to 10,000  | 0.1%         | 1,000           | Immediately  | Tuning         |

■ Model Following Control Type Selection

When you enable model following control, you can select the model following control type. Normally, set Pn14F to n.□□□1 (Use model following control type 2) (default setting). If compatibility with previous models is required, set Pn14F to n.□□□0 (Use model following control type 1).

| Parameter        | Meaning                     | When Enabled  | Classification |
|------------------|-----------------------------|---------------|----------------|
| Pn14F<br>(214Fh) | n.□□□0                      | After restart | Tuning         |
|                  | n.□□□1<br>(default setting) |               |                |

## 9.13.2 Compatible Adjustment Functions

The compatible adjustment functions are used together with manual tuning. You can use these functions to improve adjustment results. These functions allow you to use the same functions as for Σ-III-Series SERVOPACKs to adjust Σ-7-Series SERVOPACKs.

### Feedforward

The feedforward function applies feedforward compensation to position control to shorten the positioning time.

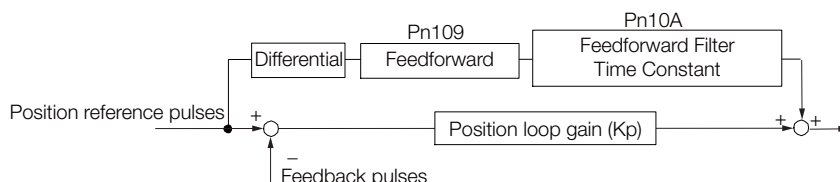

| Pn109<br>(2109h) | Feedforward                      |              |                 |              | Position       |
|------------------|----------------------------------|--------------|-----------------|--------------|----------------|
|                  | Setting Range                    | Setting Unit | Default Setting | When Enabled | Classification |
|                  | 0 to 100                         | 1%           | 0               | Immediately  | Tuning         |
| Pn10A<br>(210Ah) | Feedforward Filter Time Constant |              |                 |              | Position       |
|                  | Setting Range                    | Setting Unit | Default Setting | When Enabled | Classification |
|                  | 0 to 6,400                       | 0.01 ms      | 0               | Immediately  | Tuning         |

Note: If you set the feedforward value too high, the machine may vibrate. As a guideline, use a setting of 80% or less.

## Mode Switching (Changing between Proportional and PI Control)

You can use mode switching to automatically change between proportional control and PI control.

Overshooting caused by acceleration and deceleration can be suppressed and the settling time can be reduced by setting the switching condition and switching levels.

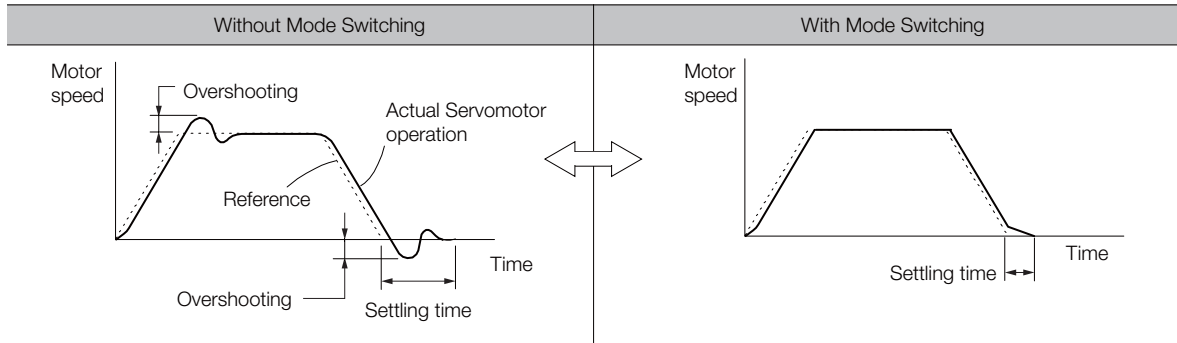

### ◆ Related Parameters

Select the switching condition for mode switching with Pn10B = n.□□□X.

| Parameter     | Mode Switching Selection | Parameter That Sets the Level                       |                   | When Enabled | Classification |
|---------------|--------------------------|---|-------------------|--------------|----------------|
|               |                          | Rotary Servomotor                                   | Linear Servomotor |              |                |
| Pn10B (210Bh) | n.□□□0 (default setting) | Use the internal torque reference as the condition. |                   | Immediately  | Setup          |
|               | n.□□□1                   | Pn10D (210Dh)                                       | Pn181 (2181h)     |              |                |
|               | n.□□□2                   | Pn10E (210Eh)                                       | Pn182 (2182h)     |              |                |
|               | n.□□□3                   | Use the position deviation as the condition.        |                   |              |                |
|               | n.□□□4                   | Do not use mode switching.                          |                   |              |                |

### ■ Parameters That Set the Switching Levels

- Rotary Servomotors

|               |   |                        |                 |              |                |
|---------------|---|------------------------|-----------------|--------------|----------------|
| Pn10C (210Ch) | Mode Switching Level for Torque Reference <span style="float:right">[Speed] [Position]</span> |                        |                 |              |                |
|               | Setting Range   | Setting Unit           | Default Setting | When Enabled | Classification |
|               | 0 to 800  | 1%                     | 200             | Immediately  | Tuning         |
| Pn10D (210Dh) | Mode Switching Level for Speed Reference <span style="float:right">[Speed] [Position]</span>  |                        |                 |              |                |
|               | Setting Range   | Setting Unit           | Default Setting | When Enabled | Classification |
|               | 0 to 10,000   | 1 min <sup>-1</sup>    | 0               | Immediately  | Tuning         |
| Pn10E (210Eh) | Mode Switching Level for Acceleration <span style="float:right">[Speed] [Position]</span>     |                        |                 |              |                |
|               | Setting Range   | Setting Unit           | Default Setting | When Enabled | Classification |
|               | 0 to 30,000   | 1 min <sup>-1</sup> /s | 0               | Immediately  | Tuning         |
| Pn10F (210Fh) | Mode Switching Level for Position Deviation <span style="float:right">[Position]</span>       |                        |                 |              |                |
|               | Setting Range   | Setting Unit           | Default Setting | When Enabled | Classification |
|               | 0 to 10,000   | 1 reference unit       | 0               | Immediately  | Tuning         |

• Linear Servomotors

| Pn10C<br>(210Ch) | Mode Switching Level for Force Reference    |                     |                 |              | Speed          | Position |
|------------------|---|---------------------|-----------------|--------------|----------------|----------|
|                  | Setting Range                               | Setting Unit        | Default Setting | When Enabled | Classification |          |
|                  | 0 to 800                                    | 1%                  | 200             | Immediately  | Tuning         |          |
| Pn181<br>(2181h) | Mode Switching Level for Speed Reference    |                     |                 |              | Speed          | Position |
|                  | Setting Range                               | Setting Unit        | Default Setting | When Enabled | Classification |          |
|                  | 0 to 10,000                                 | 1 mm/s              | 0               | Immediately  | Tuning         |          |
| Pn182<br>(2182h) | Mode Switching Level for Acceleration       |                     |                 |              | Speed          | Position |
|                  | Setting Range                               | Setting Unit        | Default Setting | When Enabled | Classification |          |
|                  | 0 to 30,000                                 | 1 mm/s <sup>2</sup> | 0               | Immediately  | Tuning         |          |
| Pn10F<br>(210Fh) | Mode Switching Level for Position Deviation |                     |                 |              | Position       |          |
|                  | Setting Range                               | Setting Unit        | Default Setting | When Enabled | Classification |          |
|                  | 0 to 10,000                                 | 1 reference unit    | 0               | Immediately  | Tuning         |          |

■ Using the Torque Reference as the Mode Switching Condition (Default Setting)

When the torque reference equals or exceeds the torque set for the mode switching level for torque reference (Pn10C), the speed loop is changed to P control.

The default setting for the torque reference level is 200%.

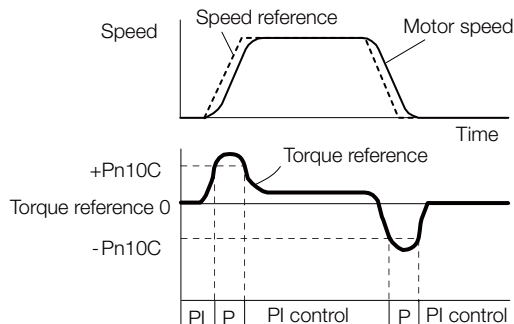

■ Using the Speed Reference as the Mode Switching Condition

• Rotary Servomotors

When the speed reference equals or exceeds the speed set for the mode switching level for a speed reference (Pn10D), the speed loop is changed to P control.

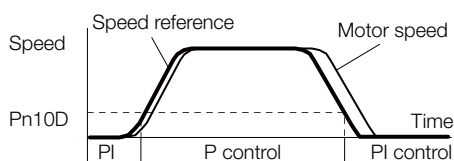

• Linear Servomotors

When the speed reference equals or exceeds the speed set for the mode switching level for a speed reference (Pn181), the speed loop is changed to P control.

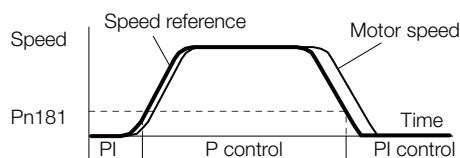

■ Using the Acceleration as the Mode Switching Condition

• Rotary Servomotors

When the speed reference equals or exceeds the acceleration rate set for the mode switching level for acceleration (Pn10E), the speed loop is changed to P control.

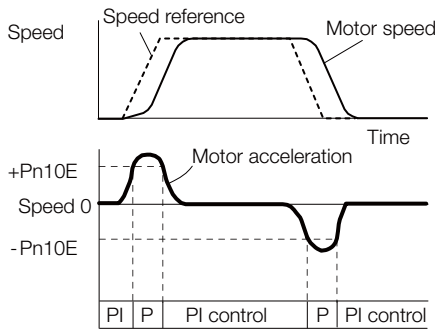

• Linear Servomotors

When the speed reference equals or exceeds the acceleration rate set for the mode switching level for acceleration (Pn182), the speed loop is changed to P control.

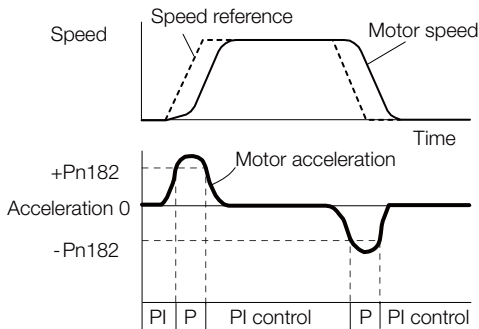

◆ Using the Position Deviation as the Mode Switching Condition

When the position deviation equals or exceeds the value set for the mode switching level for position deviation (Pn10F), the speed loop is changed to P control.

This setting is enabled only for position control.

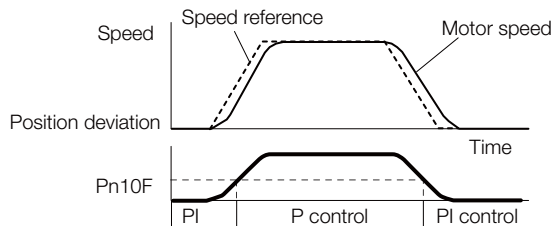

Position Integral

The position integral is the integral function of the position loop. This parameter is effective for electronic cams and electronic shafts.

| Pn11F<br>(211Fh) | Position Integral Time Constant |              |                 |              | Position       |
|------------------|---------------------------------|--------------|-----------------|--------------|----------------|
|                  | Setting Range                   | Setting Unit | Default Setting | When Enabled | Classification |
|                  | 0 to 50,000                     | 0.1 ms       | 0               | Immediately  | Tuning         |

## 9.14 Diagnostic Tools

### 9.14.1 Mechanical Analysis

#### Overview

You can connect the SERVOPACK to a computer to measure the frequency characteristics of the machine. This allows you to measure the frequency characteristics of the machine without using a measuring instrument.

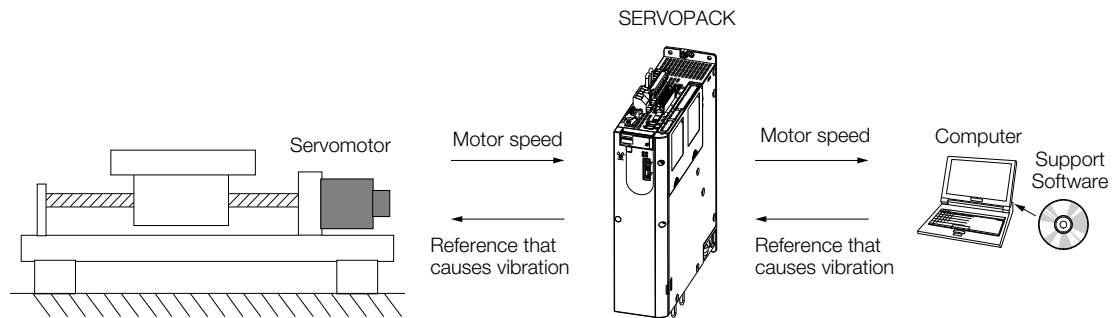

The motor is used to cause machine vibration and then the speed frequency characteristics for the motor torque are measured. The measured frequency characteristics can be used to determine the machine resonance.

You determine the machine resonance for use in servo tuning and as reference for considering changes to the machine. The performance of the servo cannot be completely utilized depending on the rigidity of the machine. You may need to consider making changes to the machine. The information can also be used as reference for servo tuning to help you adjust parameters, such as the servo rigidity and torque filter time constant.

You can also use the information to set parameters, such as the notch filters.

#### WARNING

- Mechanical analysis requires operating the motor and therefore presents hazards. Before you execute mechanical analysis, check the information provided in the SigmaWin+ operating manual.

## Frequency Characteristics

The motor is used to cause the machine to vibrate and the frequency characteristics from the torque to the motor speed are measured to determine the machine characteristics. For a normal machine, the resonance frequencies are clear when the frequency characteristics are plotted on graphs with the gain and phase (bode plots). The bode plots show the size (gain) of the response of the machine to which the torque is applied, and the phase delay (phase) in the response for each frequency. Also, the machine resonance frequency can be determined from the maximum frequency of the valleys (anti-resonance) and peaks (resonance) of the gain and the phase delay.

For a motor without a load or for a rigid mechanism, the gain and phase change gradually in the bode plots.

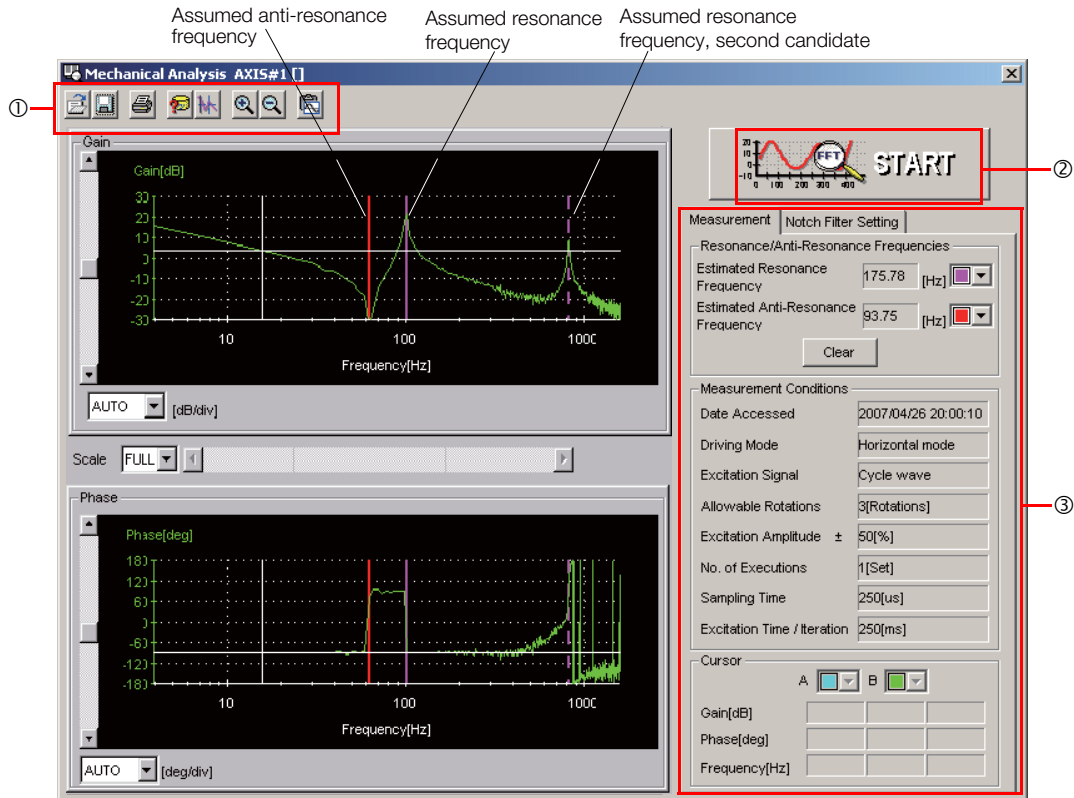

① Toolbar

② **START** Button

Click the **START** Button to start analysis.

③ **Measurement** and **Notch Filter Setting** Tab Pages

**Measurement** Tab Page: Displays detailed information on the results of analysis.

**Notch Filter Setting** Tab Page: Displays the notch filter frequencies. You can set these values in the parameters.

## 9.14.2 Easy FFT

The machine is made to vibrate and a resonance frequency is detected from the generated vibration to set notch filters according to the detected resonance frequencies. This is used to eliminate high-frequency vibration and noise.

During execution of Easy FFT, a frequency waveform reference is sent from the SERVOPACK to the Servomotor to automatically cause the shaft to rotate multiple times within 1/4th of a rotation, thus causing the machine to vibrate.

Execute Easy FFT after the servo is turned OFF if operation of the SERVOPACK results in high-frequency noise and vibration.

### WARNING

- Never touch the Servomotor or machine during execution of Easy FFT. Doing so may result in injury.

### CAUTION

- Use Easy FFT when the servo gain is low, such as in the initial stage of servo tuning. If you execute Easy FFT after you increase the gain, the machine may vibrate depending on the machine characteristics or gain balance.

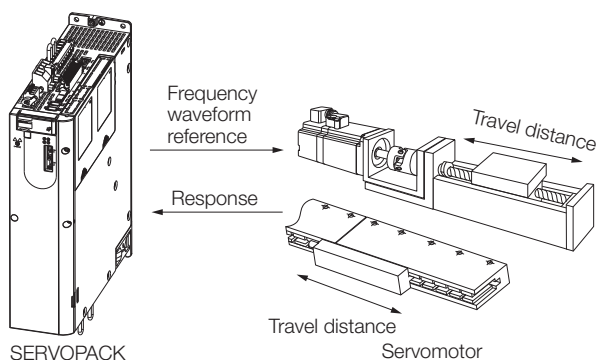

Easy FFT is built into the SERVOPACK for compatibility with previous products. Normally use autotuning without a host reference for tuning.

## Preparations

Check the following settings before you execute Easy FFT.

- The parameters must not be write prohibited.
- The main circuit power supply must be ON.
- The test without a motor function must be disabled (Pn00C = n.□□□0).
- There must be no alarms.
- There must be no hard wire base block (HWBB).
- The servo must be OFF.
- There must be no overtravel.
- An external reference must not be input.

## Applicable Tools

The following table lists the tools that you can use to perform EasyFFT.

| Tool             | Fn No./Function Name         | Operating Procedure Reference  |
|------------------|------------------------------|--|
| Digital Operator | Fn206                        | Σ-7-Series Digital Operator Operating Manual (Manual No.: SIEP S800001 33) |
| SigmaWin+        | <b>Diagnostic – Easy FFT</b> | Operating Procedure on page 9-94   |

## Operating Procedure

Use the following procedure.

1. Click the  Servo Drive Button in the workspace of the Main Window of the SigmaWin+.
2. Select **Easy FFT** in the Menu Dialog Box.  
The Easy FFT Dialog Box will be displayed.  
Click the **Cancel** Button to cancel Easy FFT. You will return to the main window.
3. Click the **OK** Button.



4. Click the **Servo ON** Button.

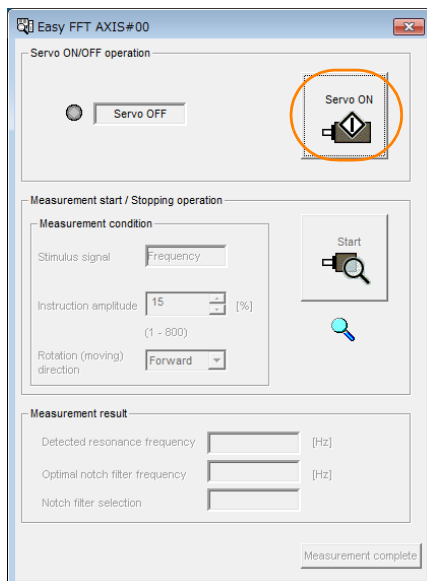



5. Select the instruction (reference) amplitude and the rotation direction in the **Measurement condition Area**, and then click the **Start Button**.

The motor shaft will rotate and measurements will start.

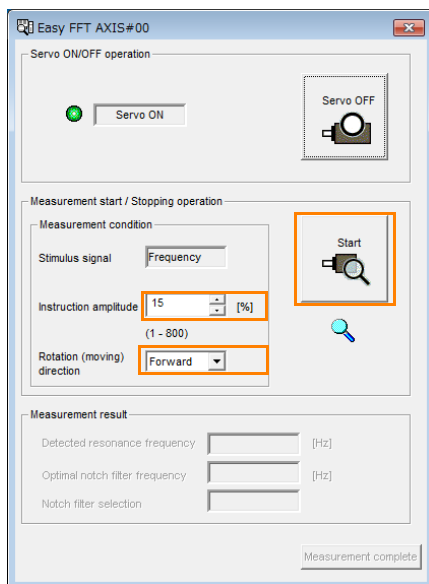

When measurements have been completed, the measurement results will be displayed.

6. Check the results in the **Measurement result Area** and then click the **Measurement complete Button**.

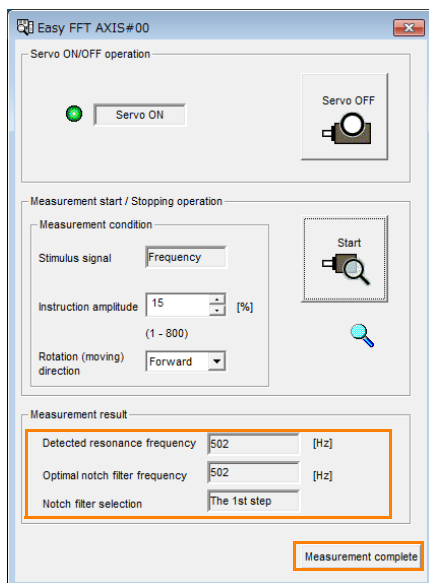

7. Click the **Result Writing Button** if you want to set the measurement results in the parameters.

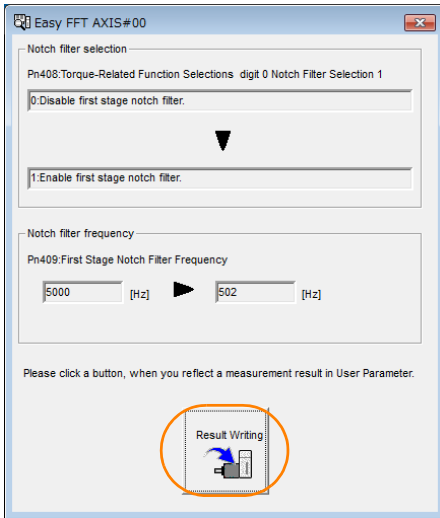

This concludes the procedure to set up Easy FFT.

### Related Parameters

The following parameters are automatically adjusted or used as reference when you execute Easy FFT.

Do not change the settings of these parameters during execution of Easy FFT.

| Parameter     | Name                                | Automatic Changes |
|---------------|-------------------------------------|-------------------|
| Pn408 (2408h) | Torque-Related Function Selections  | Yes               |
| Pn409 (2409h) | First Stage Notch Filter Frequency  | Yes               |
| Pn40A (240Ah) | First Stage Notch Filter Q Value    | No                |
| Pn40C (240Ch) | Second Stage Notch Filter Frequency | Yes               |
| Pn40D (240Dh) | Second Stage Notch Filter Q Value   | No                |
| Pn456 (2456h) | Sweep Torque Reference Amplitude    | No                |

Yes: The parameter is automatically set.

No: The parameter is not automatically set, but the setting is read during execution.

# Monitoring

# 10

This chapter provides information on monitoring SERVO-  
PACK product information and SERVOPACK status.

|             |   |              |
|-------------|---|--------------|
| <b>10.1</b> | <b>Monitoring Product Information</b>                           | <b>10-2</b>  |
| 10.1.1      | Items That You Can Monitor                                      | 10-2         |
| 10.1.2      | Operating Procedures  | 10-2         |
| <b>10.2</b> | <b>Monitoring SERVOPACK Status</b>                              | <b>10-3</b>  |
| 10.2.1      | Servo Drive Status  | 10-3         |
| 10.2.2      | Monitoring Operation, Status, and I/O                           | 10-3         |
| 10.2.3      | I/O Signals Status Monitor                                      | 10-5         |
| <b>10.3</b> | <b>Monitoring Machine Operation Status and Signal Waveforms</b> | <b>10-7</b>  |
| 10.3.1      | Items That You Can Monitor                                      | 10-7         |
| 10.3.2      | Using the SigmaWin+   | 10-8         |
| 10.3.3      | Using a Measuring Instrument                                    | 10-9         |
| <b>10.4</b> | <b>Monitoring Product Life</b>                                  | <b>10-14</b> |
| 10.4.1      | Items That You Can Monitor                                      | 10-14        |
| 10.4.2      | Operating Procedure   | 10-15        |
| 10.4.3      | Preventative Maintenance  | 10-15        |
| <b>10.5</b> | <b>Alarm Tracing</b>  | <b>10-17</b> |
| 10.5.1      | Data for Which Alarm Tracing Is Performed                       | 10-17        |
| 10.5.2      | Applicable Tools  | 10-17        |

# 10.1 Monitoring Product Information

## 10.1.1 Items That You Can Monitor

| Monitor Items              |  |
|----------------------------|--|
| Information on SERVOPACKs  | <ul style="list-style-type: none"> <li>• Model/Type</li> <li>• Serial Number</li> <li>• Manufacturing Date</li> <li>• Software version (SW Ver.)</li> <li>• Remarks</li> </ul> |
| Information on Servomotors | <ul style="list-style-type: none"> <li>• Model/Type</li> <li>• Serial Number</li> <li>• Manufacturing Date</li> <li>• Remarks</li> </ul>                                       |
| Information on Encoders    | <ul style="list-style-type: none"> <li>• Model/Type</li> <li>• Serial Number</li> <li>• Manufacturing Date</li> <li>• Software version (SW Ver.)</li> <li>• Remarks</li> </ul> |

## 10.1.2 Operating Procedures

Use the following procedure to display the Servo Drive product information.

- Select **Read Product Information** in the Menu Dialog Box of the SigmaWin+. The Read Product Information Window will be displayed.

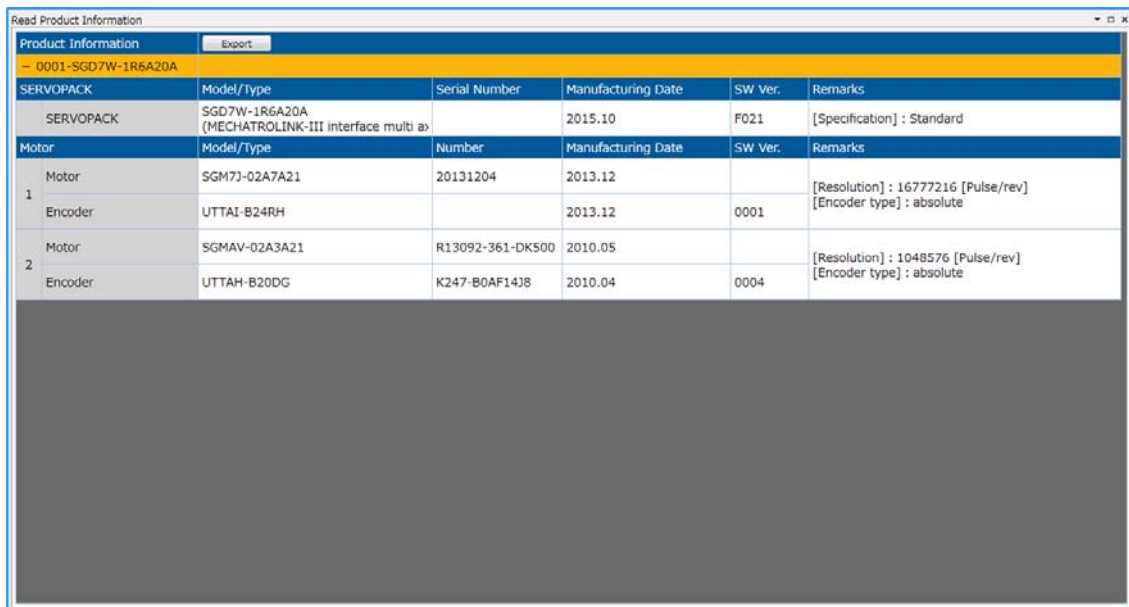

**Information** With the Digital Operator, you can use Fn011, Fn012, and Fn01E to monitor this information. Refer to the following manual for the differences in the monitor items compared with the SigmaWin+.

Σ-7-Series Digital Operator Operating Manual (Manual No.: SIEP S800001 33)

# 10.2 Monitoring SERVOPACK Status

## 10.2.1 Servo Drive Status

Use the following procedure to display the Servo Drive status.

- Start the SigmaWin+. The Servo Drive status will be automatically displayed when you go online with a SERVOPACK.

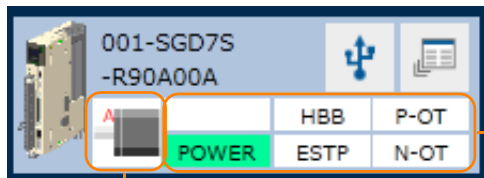

The Servo Drive status is displayed.

The Servomotor type is displayed.

## 10.2.2 Monitoring Operation, Status, and I/O

### Items That You Can Monitor

The items that you can monitor on the Operation Pane, Status Pane, and I/O Pane are listed below.

- Operation Pane

| Monitor Items  |  |
|--|--|
| <ul style="list-style-type: none"> <li>• Motor Speed</li> <li>• Speed Reference</li> <li>• Internal Torque Reference</li> <li>• Angle of Rotation 1 (number of encoder pulses from encoder phase C)</li> <li>• Angle of Rotation 2 (electrical angle from polarity origin)</li> <li>• Input Reference Pulse Speed</li> <li>• Deviation Counter (Position Deviation)</li> <li>• Cumulative Load</li> <li>• Regenerative Load</li> <li>• DB Resistor Consumption Power</li> <li>• Absolute Encoder Multiturn Data</li> <li>• Absolute Encoder Position within One Rotation</li> <li>• Lower Bits of Absolute Encoder Position</li> <li>• Upper Bits of Absolute Encoder Position</li> <li>• Input Reference Pulse Counter</li> </ul> | <ul style="list-style-type: none"> <li>• Feedback Pulse Counter</li> <li>• Total Operating Time</li> <li>• Current Backlash Compensation Value</li> <li>• Backlash Compensation Value Setting Limit</li> <li>• Position Amplifier Deviation</li> <li>• Feedback Position (APOS)</li> <li>• Current Reference Position (CPOS)</li> <li>• Position Deviation (PERR)</li> <li>• Target Position (TPOS)</li> <li>• Latched Position 1 (LPOS1)</li> <li>• Latched Position 2 (LPOS2)</li> <li>• Latched Position 3 (LPOS3)</li> <li>• Target Speed (TSPD)</li> <li>• Feedback Speed (FSPD)</li> <li>• Current Position Command Speed (CSPD)</li> <li>• Torque Limit (TRQ_LIM)</li> <li>• Speed Limit (SPD_LIM)</li> </ul> |

- Status Pane

| Monitor Items  |   |
|--|---|
| <ul style="list-style-type: none"> <li>• Polarity Sensor Signal Monitor</li> <li>• Active Gain Monitor</li> <li>• Main Circuit</li> <li>• Encoder (PGRDY)</li> <li>• Motor Power (Request)</li> <li>• Motor Power ON</li> <li>• Dynamic Brake (DB)</li> <li>• Rotation (Movement) Direction</li> <li>• Mode Switch</li> <li>• Speed Reference (V-Ref)</li> <li>• Torque Reference (T-Ref)</li> </ul> | <ul style="list-style-type: none"> <li>• Position Reference (PULS)</li> <li>• Position Reference Direction</li> <li>• Surge Current Limiting Resistor Short Relay</li> <li>• Regenerative Transistor</li> <li>• Regenerative Error Detection</li> <li>• AC Power ON</li> <li>• Overcurrent</li> <li>• Origin Not Passed</li> <li>• Moment of Inertia Identification</li> <li>• Polarity Detection in Progress</li> <li>• Completion of Polarity Detection</li> <li>• Ripple Compensation in Progress</li> </ul> |

- I/O Pane

| Monitor Items       |   |   |
|---------------------|---|---|
| Input Signal Status | <ul style="list-style-type: none"> <li>• P-OT (Forward Drive Prohibit Input Signal)</li> <li>• N-OT (Reverse Drive Prohibit Input Signal)</li> <li>• /P-CL (Forward External Torque Limit Signal)</li> <li>• /N-CL (Reverse External Torque Limit Signal)</li> <li>• /G-SEL (Gain Selection Input Signal)</li> <li>• /P-DET (Polarity Detection Input Signal)</li> <li>• /ALM-RST (Alarm Reset Input Signal)</li> <li>• /Probe1 (Probe 1 Latch Input Signal)</li> <li>• /Probe2 (Probe 2 Latch Input Signal)</li> <li>• /Home (Home Switch Input Signal)</li> <li>• /DEC (Origin Return Deceleration Switch Input Signal)</li> <li>• FSTP (Forced Stop Input Signal)</li> </ul> | Output Signal Status  |
|                     |   | <ul style="list-style-type: none"> <li>• ALM (Servo Alarm Output Signal)</li> <li>• /COIN (Positioning Completion Output Signal)</li> <li>• /V-CMP (Speed Coincidence Detection Output Signal)</li> <li>• /TGON (Rotation Detection Output Signal)</li> <li>• /S-RDY (Servo Ready Output Signal)</li> <li>• /CLT (Torque Limit Detection Signal)</li> <li>• /VLT (Speed Limit Detection Output Signal)</li> <li>• /BK (Brake Output Signal)</li> <li>• /WARN (Warning Output Signal)</li> <li>• /NEAR (Near Output Signal)</li> <li>• /PM (Preventative Maintenance Output Signal)</li> </ul> |

## Operating Procedure

Use the following procedure to display the Operation Monitor, Status Monitor, and I/O Monitor for the SERVOPACK.

- Select **Monitor** in the SigmaWin+ Menu Dialog Box. The Operation Pane, Status Pane, and I/O Pane will be displayed in the Monitor Window.

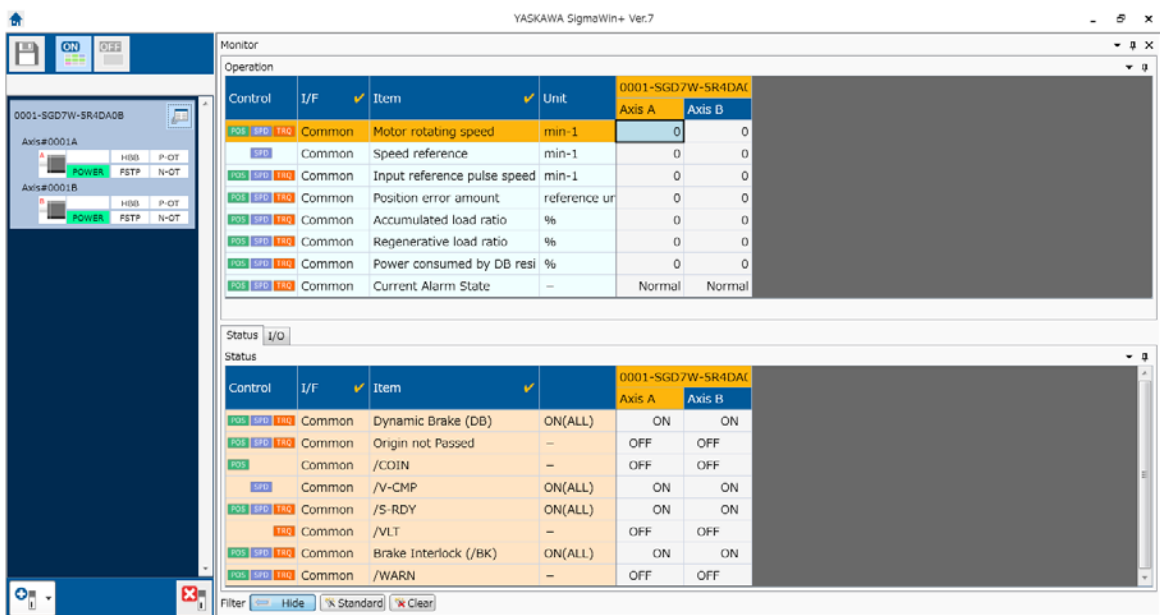

**Information** You can flexibly change the contents that are displayed in the Monitor Window. Refer to the following manual for details.  
 📖 *Engineering Tool SigmaWin+ Operation Manual* (Manual No.: SIET S800001 34)

## 10.2.3 I/O Signals Status Monitor

Use the following procedure to check the status of the I/O signals.

1. Click the  Servo Drive Button in the workspace of the Main Window of the SigmaWin+.
2. Select **I/O Signal Allocation** in the Menu Dialog Box. The I/O Signal Allocation Window will be displayed.
3. Click the **Input Signal** Tab.

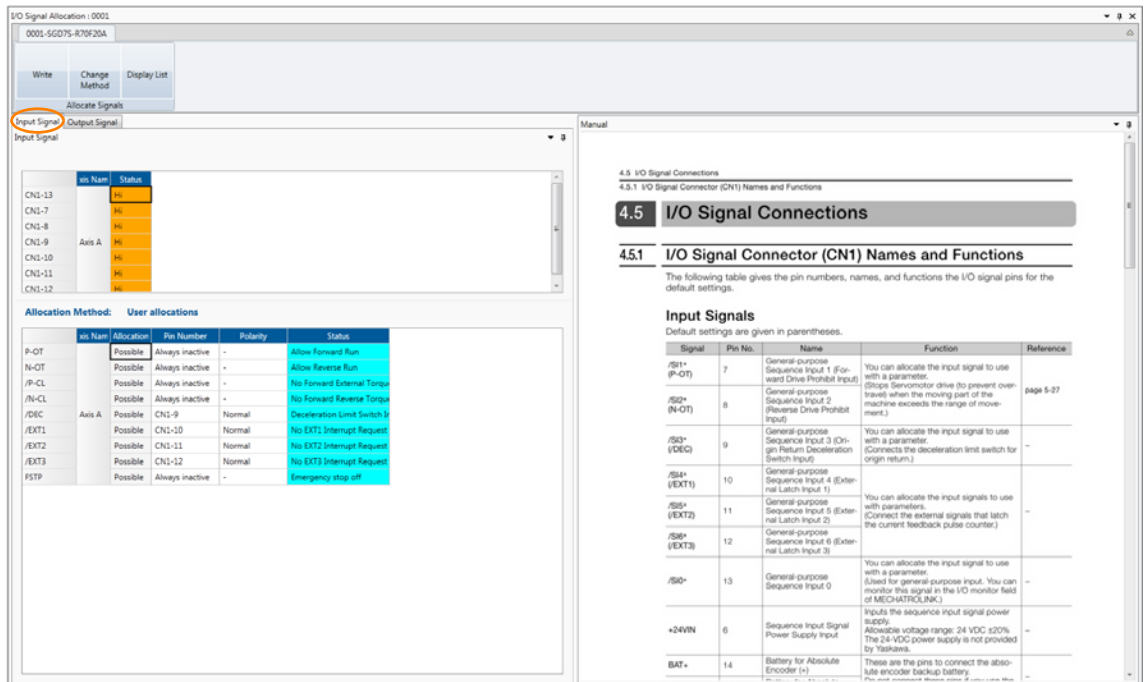

The screenshot shows the 'I/O Signal Allocation : 0001' window for device '0001-SGD7S-R70F2DA'. The 'Input Signal' tab is selected, showing a table of input signals for Axis A. A red circle highlights the 'Input Signal' tab. To the right, a manual page titled '4.5 I/O Signal Connections' is visible, with a sub-section '4.5.1 I/O Signal Connector (CN1) Names and Functions' containing a table of signal names and functions.

| Signal       | Pin No. | Name   | Function  | Reference |
|--------------|---------|--|---|-----------|
| /SI1+ (P-OT) | 7       | General-purpose Sequence Input 1 (Forward Drive Prohibit Input)            | You can allocate the input signal to use with a parameter. (Stops Servomotor drive (to prevent over-travel) when the moving part of the machine exceeds the range of movement.) | page 5-27 |
| /SI2+ (N-OT) | 8       | General-purpose Sequence Input 2 (Reverse Drive Prohibit Input)            |   |           |
| /SI3+ (DEC)  | 9       | General-purpose Sequence Input 3 (Origin Return Deceleration Switch Input) | You can allocate the input signal to use with a parameter. (Connects the deceleration limit switch for origin return.)  |           |
| /SI4+ (EXT1) | 10      | General-purpose Sequence Input 4 (External Latch Input 1)                  |   |           |
| /SI5+ (EXT2) | 11      | General-purpose Sequence Input 5 (External Latch Input 2)                  | You can allocate the input signals to use with parameters. (Connect the external signals that latch the current feedback pulse counter.)  |           |
| /SI6+ (EXT3) | 12      | General-purpose Sequence Input 6 (External Latch Input 3)                  |   |           |
| /SI0+        | 13      | General-purpose Sequence Input 0   | You can allocate the input signal to use with a parameter. (Used for general-purpose input. You can monitor this signal in the I/O monitor field of MECHATROLINK.)              |           |
| +24VIN       | 6       | Sequence Input Signal Power Supply Input                                   | Inputs the sequence input signal power supply. Allowable voltage range: 24 VDC ±20%. The 24-VDC power supply is not provided by Yaskawa.  |           |
| BAT+         | 14      | Battery for Absolute Encoder (+)   | These are the pins to connect the absolute encoder backup battery. (Pin 14 and connector shield are shorted.)   |           |

Check the status of the input signals.

4. Click the **Output Signal** Tab.

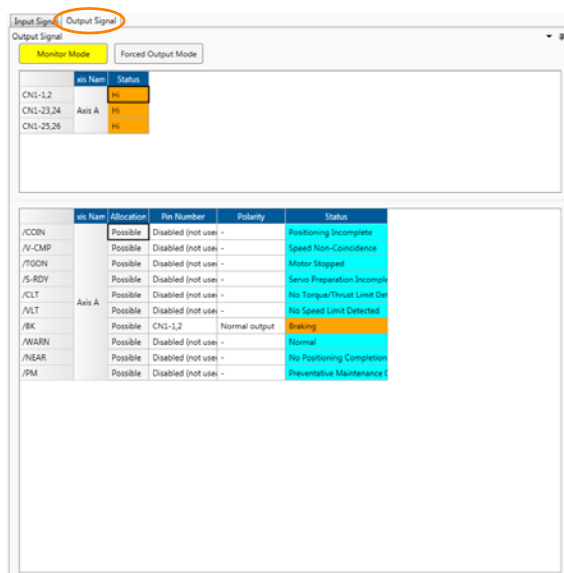

The screenshot shows the 'Output Signal' tab selected in the 'I/O Signal Allocation' window. It displays a table of output signals for Axis A. A red circle highlights the 'Output Signal' tab.

| Signal | Pin No. | Name                            | Function | Reference |
|--------|---------|---------------------------------|----------|-----------|
| /COIN  |         | Positioning Incomplete          |          |           |
| /V-CMP |         | Speed Non-Coincidence           |          |           |
| /TGOIN |         | Motor Stopped                   |          |           |
| /S-BDY |         | Servo Preparation Incomplete    |          |           |
| /CLT   |         | No Torque/Thrust Limit Detected |          |           |
| /VLT   |         | No Speed Limit Detected         |          |           |
| /BK    | CN1-1,2 | Braking                         |          |           |
| /WARN  |         | Normal                          |          |           |
| /NEAR  |         | No Positioning Completion       |          |           |
| /PM    |         | Preventative Maintenance        |          |           |

Check the status of the output signals.

#### Information

You can also use the above window to check wiring.

- Checking Input Signal Wiring

Change the signal status at the host controller. If the input signal status on the window changes accordingly, then the wiring is correct.

- Checking Output Signal Wiring

Click the **Force Output Mode** Button. This will force the output signal status to change. If the signal status at the host controller changes accordingly, then the wiring is correct.

You cannot use the **Force Output Mode** Button while the servo is ON.

For details, refer to the following manual.

 AC Servo Drive Engineering Tool SigmaWin+ Operation Manual (Manual No.: SIET S800001 34)



# 10.3 Monitoring Machine Operation Status and Signal Waveforms

To monitor waveforms, use the SigmaWin+ trace function or a measuring instrument, such as a memory recorder.

## 10.3.1 Items That You Can Monitor

You can use the SigmaWin+ or a measuring instrument to monitor the shaded items in the following block diagram.

- Rotary Servomotors

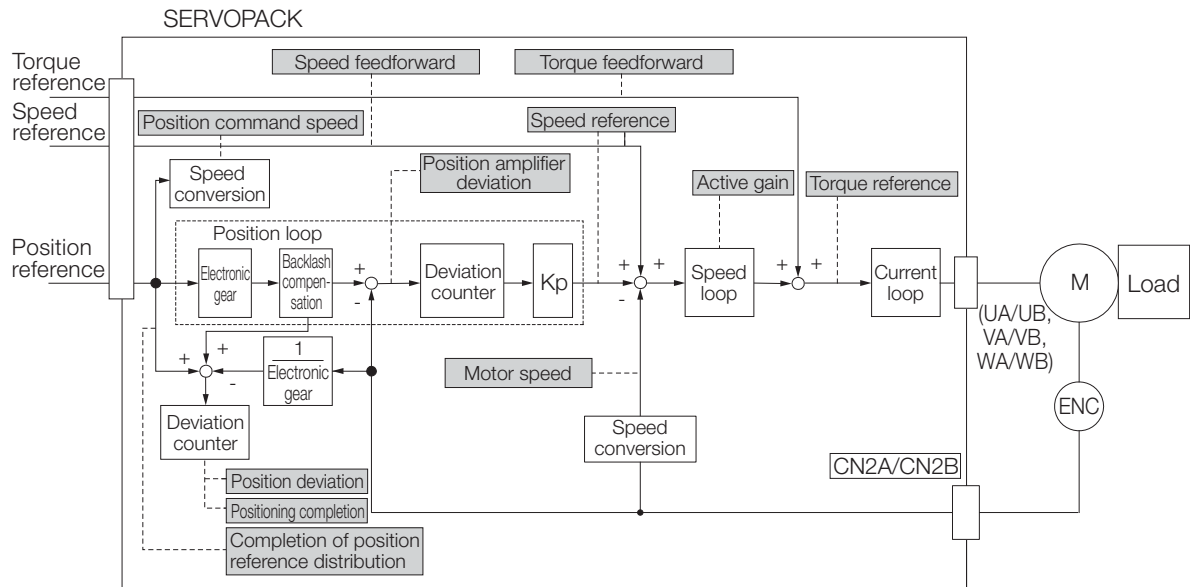

- Linear Servomotors

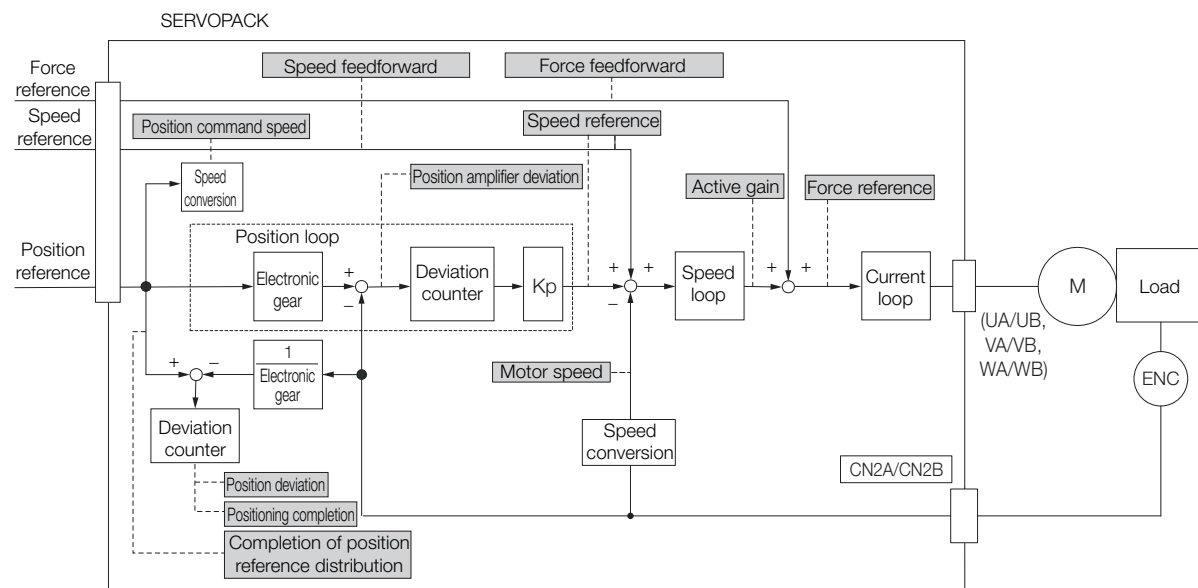

## 10.3.2 Using the SigmaWin+

This section describes how to trace data and I/O with the SigmaWin+.

Refer to the following manual for detailed operating procedures for the SigmaWin+.

Engineering Tool SigmaWin+ Operation Manual (Manual No.: SIET S800001 34)

### Operating Procedure

1. Click the Servo Drive Button in the workspace of the Main Window of the SigmaWin+.
2. Select Trace in the Menu Dialog Box.  
The Trace Dialog Box will be displayed.

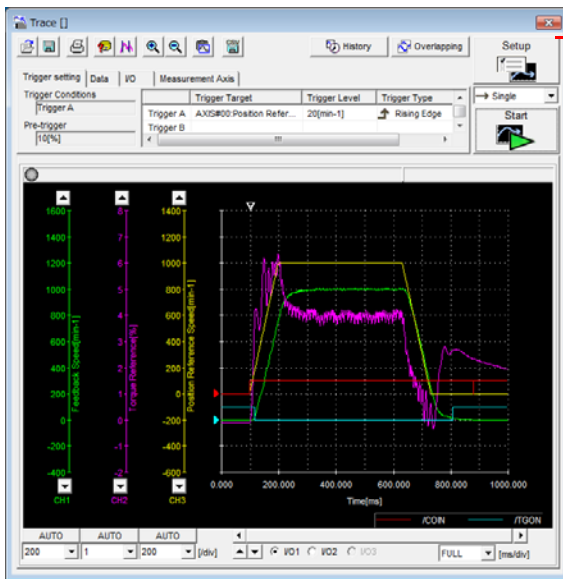

Click this button to display the Trace Setting Dialog Box shown below, and set the data to trace and the trace conditions.

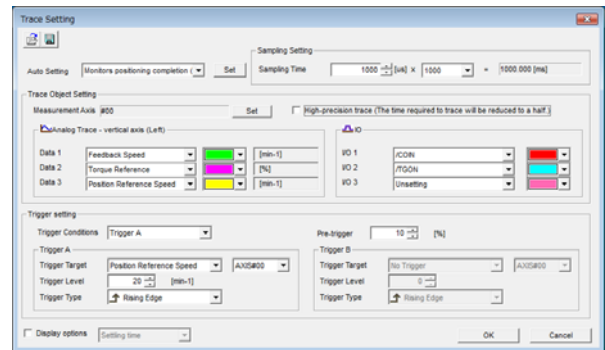

### Trace Objects

You can trace the following items.

- Data Tracing

| Trace Objects   |   |
|---|---|
| <ul style="list-style-type: none"> <li>• Torque Reference</li> <li>• Feedback Speed</li> <li>• Reference Speed</li> <li>• Position Reference Speed</li> <li>• Position Error (Deviation)</li> <li>• Position Amplifier Error (Deviation)</li> </ul> | <ul style="list-style-type: none"> <li>• Speed Feedforward</li> <li>• Torque Feedforward</li> <li>• Effective (Active) Gain</li> <li>• Main Circuit DC Voltage</li> <li>• Control Mode</li> </ul> |

• I/O Tracing

| Trace Objects |  |  |
|---------------|--|--|
| Input Signals | <ul style="list-style-type: none"> <li>• P-OT (Forward Drive Prohibit Input Signal)</li> <li>• N-OT (Reverse Drive Prohibit Input Signal)</li> <li>• /ALM-RST (Alarm Reset Input Signal)</li> <li>• /P-CL (Forward External Torque/Force Limit Input Signal)</li> <li>• /N-CL (Reverse External Torque/Force Limit Input Signal)</li> <li>• /Probe1 (Probe 1 Latch Input Signal)</li> <li>• /Probe2 (Probe 2 Latch Input Signal)</li> <li>• /Home (Home Switch Input Signal)</li> <li>• FSTP (Forced Stop Input Signal)</li> <li>• /HWBB1 (Hard Wire Base Block Input 1 Signal)</li> <li>• /HWBB2 (Hard Wire Base Block Input 2 Signal)</li> </ul> | <ul style="list-style-type: none"> <li>• ALM (Servo Alarm Output Signal)</li> <li>• /COIN (Positioning Completion Output Signal)</li> <li>• /V-CMP (Speed Coincidence Detection Output Signal)</li> <li>• /TGON (Rotation Detection Output Signal)</li> <li>• /S-RDY (Servo Ready Output Signal)</li> <li>• /CLT (Torque Limit Detection Output Signal)</li> <li>• /VLT (Speed Limit Detection Output Signal)</li> <li>• /BK (Brake Output Signal)</li> <li>• /WARN (Warning Output Signal)</li> <li>• /NEAR (Near Output Signal)</li> </ul> |
|               |  | <ul style="list-style-type: none"> <li>• ACON (Main Circuit ON Signal)</li> <li>• PDETCMP (Polarity Detection Completed Signal)</li> <li>• DEN (Position Reference Distribution Completed Signal)</li> </ul>   |

## 10.3.3 Using a Measuring Instrument

Connect a measuring instrument, such as a memory recorder, to the analog monitor connector (CN5) on the SERVOPACK to monitor analog signal waveforms. The measuring instrument is not provided by Yaskawa.

Refer to the following section for details on the connection.

 4.8.3 Analog Monitor Connector (CN5) on page 4-48

### Setting the Monitor Object

Use Pn006 = n.X□□□ and Pn007 = n.X□□□ (Output Axis Selection) to set the axis to monitor.

| Parameter               | Description              | When Enabled | Classification |
|-------------------------|--------------------------|--------------|----------------|
| Pn006 (2006h)           | n.0□□□ (default setting) | Immediately  | Setup          |
| Pn007 (2007h)<br>Common | n.1□□□                   |              |                |

Use Pn006 = n.□□XX and Pn007 = n.□□XX (Analog Monitor 1 and 2 Signal Selections) to set the items to monitor.

| Line Color      | Signal           | Parameter Setting      |
|-----------------|------------------|------------------------|
| White           | Analog monitor 1 | Pn006 (2006h) = n.□□XX |
| Red             | Analog monitor 2 | Pn007 (2007h) = n.□□XX |
| Black (2 lines) | GND              | -                      |

10.3 Monitoring Machine Operation Status and Signal Waveforms

10.3.3 Using a Measuring Instrument

| Parameter   |                                      | Description                                   |  |   |
|---|--------------------------------------|---|--|---|
|   |                                      | Monitor Signal                                | Output Unit  | Remarks   |
| Pn006<br>(2006h) or<br>Pn007<br>(2007h)<br>Common | n.□□00<br>(default setting of Pn007) | Motor Speed                                   | <ul style="list-style-type: none"> <li>Rotary Servomotor: 1 V/1,000 min<sup>-1</sup></li> <li>Linear Servomotor: 1 V/1,000 mm/s</li> </ul> | –   |
|   | n.□□01                               | Speed Reference                               | <ul style="list-style-type: none"> <li>Rotary Servomotor: 1 V/1,000 min<sup>-1</sup></li> <li>Linear Servomotor: 1 V/1,000 mm/s</li> </ul> | –   |
|   | n.□□02<br>(default setting of Pn006) | Torque Reference                              | 1 V/100% rated torque  | –   |
|   | n.□□03                               | Position Deviation                            | 0.05 V/Reference unit  | 0 V for speed or torque control                             |
|   | n.□□04                               | Position Amplifier Deviation                  | 0.05 V/encoder pulse unit  | Position deviation after electronic gear conversion         |
|   | n.□□05                               | Position Command Speed                        | <ul style="list-style-type: none"> <li>Rotary Servomotor: 1 V/1,000 min<sup>-1</sup></li> <li>Linear Servomotor: 1 V/1,000 mm/s</li> </ul> | –   |
|   | n.□□06                               | Reserved parameter (Do not change.)           | –  | –   |
|   | n.□□07                               | Reserved parameter (Do not change.)           | –  | –   |
|   | n.□□08                               | Positioning Completion                        | Positioning completed: 5 V<br>Positioning not completed: 0 V   | Completion is indicated by the output voltage.              |
|   | n.□□09                               | Speed Feedforward                             | <ul style="list-style-type: none"> <li>Rotary Servomotor: 1 V/1,000 min<sup>-1</sup></li> <li>Linear Servomotor: 1 V/1,000 mm/s</li> </ul> | –   |
|   | n.□□0A                               | Torque Feedforward                            | 1 V/100% rated torque  | –   |
|   | n.□□0B                               | Active Gain*                                  | 1st gain: 1 V<br>2nd gain: 2 V   | The gain that is active is indicated by the output voltage. |
|   | n.□□0C                               | Completion of Position Reference Distribution | Distribution completed: 5 V<br>Distribution not completed: 0 V   | Completion is indicated by the output voltage.              |
|   | n.□□0D                               | Reserved parameter (Do not change.)           | –  | –   |
| n.□□10  | Main Circuit DC Voltage              | 1 V/100 V (main circuit DC voltage)           | –  |   |

\* Refer to the following section for details.  
 9.12.1 Gain Switching on page 9-65

## Changing the Monitor Factor and Offset

You can change the monitor factors and offsets for the output voltages for analog monitor 1 and analog monitor 2. The relationships to the output voltages are as follows:

$$\text{Analog monitor 1 output voltage} = (-1) \times \left\{ \begin{array}{l} \text{Analog Monitor 1 Signal} \\ \text{Selection (Pn006 = n.}\square\square\text{XX)} \end{array} \times \begin{array}{l} \text{Analog Monitor 1} \\ \text{Magnification (Pn552)} \end{array} + \begin{array}{l} \text{Analog Monitor 1} \\ \text{Offset Voltage (Pn550)} \end{array} \right\}$$

$$\text{Analog monitor 2 output voltage} = (-1) \times \left\{ \begin{array}{l} \text{Analog Monitor 2 Signal} \\ \text{Selection (Pn007 = n.}\square\square\text{XX)} \end{array} \times \begin{array}{l} \text{Analog Monitor 2} \\ \text{Magnification (Pn553)} \end{array} + \begin{array}{l} \text{Analog Monitor 2} \\ \text{Offset Voltage (Pn551)} \end{array} \right\}$$

The following parameters are set.

|                            |                                 |              |                 |              |                |          |        |
|----------------------------|---------------------------------|--------------|-----------------|--------------|----------------|----------|--------|
| Pn550<br>(2550h)<br>Common | Analog Monitor 1 Offset Voltage |              |                 |              | Speed          | Position | Torque |
|                            | Setting Range                   | Setting Unit | Default Setting | When Enabled | Classification |          |        |
|                            | -10,000 to 10,000               | 0.1 V        | 0               | Immediately  | Setup          |          |        |
| Pn551<br>(2551h)<br>Common | Analog Monitor 2 Offset Voltage |              |                 |              | Speed          | Position | Torque |
|                            | Setting Range                   | Setting Unit | Default Setting | When Enabled | Classification |          |        |
|                            | -10,000 to 10,000               | 0.1 V        | 0               | Immediately  | Setup          |          |        |
| Pn552<br>(2552h)<br>Common | Analog Monitor 1 Magnification  |              |                 |              | Speed          | Position | Torque |
|                            | Setting Range                   | Setting Unit | Default Setting | When Enabled | Classification |          |        |
|                            | -10,000 to 10,000               | ×0.01        | 100             | Immediately  | Setup          |          |        |
| Pn553<br>(2553h)<br>Common | Analog Monitor 2 Magnification  |              |                 |              | Speed          | Position | Torque |
|                            | Setting Range                   | Setting Unit | Default Setting | When Enabled | Classification |          |        |
|                            | -10,000 to 10,000               | ×0.01        | 100             | Immediately  | Setup          |          |        |

### Example

- Example for Setting the Item to Monitor to the Motor Speed (Pn006 = n.□□00)

When Pn552 = 100 (Setting Unit: ×0.01)

When Pn552 = 1,000 (Setting Unit: ×0.01)

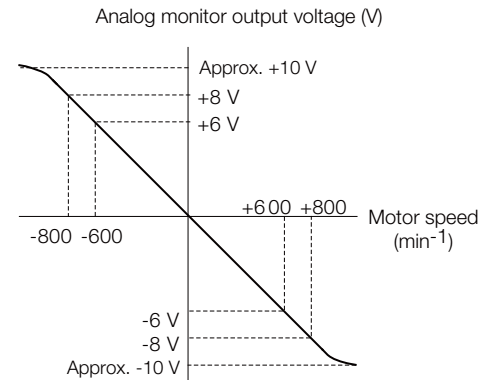
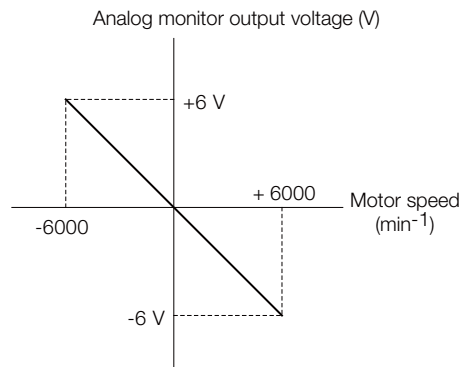

Note: The effective linearity range is ±8 V.  
The resolution is 16 bits.

## Adjusting the Analog Monitor Output

You can manually adjust the offset and gain for the analog monitor outputs for the torque reference monitor and motor speed monitor.

The offset is adjusted to compensate for offset in the zero point caused by output voltage drift or noise in the monitoring system.

The gain is adjusted to match the sensitivity of the measuring system.

The offset and gain are adjusted at the factory. You normally do not need to adjust them.



The analog monitor output adjustment applies to both axes A and B.  
If you change the adjustment, the new adjustment will be applied to both axes.

### ◆ Adjustment Example

An example of adjusting the output of the motor speed monitor is provided below.

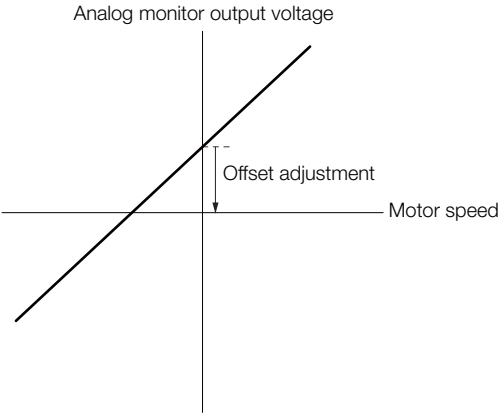
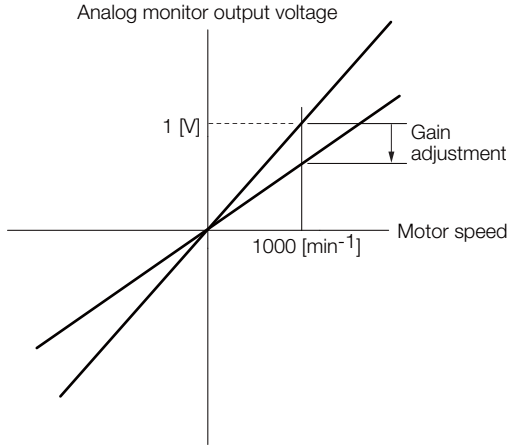
| Offset Adjustment   |                 | Gain Adjustment  |               |
|---|-----------------|--|---------------|
|  |                 |  |               |
| Item  | Specification   | Item   | Specification |
| Offset Adjustment Range   | -2.4 V to 2.4 V | Gain Adjustment Range  | 100 ±50%      |
| Adjustment Unit   | 18.9 mV/LSB     | Adjustment Unit  | 0.4%/LSB      |

The gain adjustment range is made using a 100% output value (gain adjustment of 0) as the reference value with an adjustment range of 50% to 150%. A setting example is given below.

- Setting the Adjustment Value to -125  
 $100 + (-125 \times 0.4) = 50 \text{ [%]}$   
 Therefore, the monitor output voltage goes to 50% of the original value.
- Setting the Adjustment Value to 125  
 $100 + (125 \times 0.4) = 150 \text{ [%]}$   
 Therefore, the monitor output voltage goes to 150% of the original value.

- Information**
- The adjustment values do not use parameters, so they will not change even if the parameter settings are initialized.
  - Adjust the offset with the measuring instrument connected so that the analog monitor output value goes to zero. The following setting example achieves a zero output.
    - While power is not supplied to the Servomotor, set the monitor signal to the torque reference.
    - In speed control, set the monitor signal to the position deviation.

### ◆ Preparations



Always check the following before you adjust the analog monitor output.

- The parameters must not be write prohibited.

### ◆ Applicable Tools

You can use the following tools to adjust analog monitor outputs.

- Offset Adjustment

| Tool             | Fn No./Function Name                             | Operating Procedure Reference  |
|------------------|--|--|
| Digital Operator | Fn00C  |  Σ-7-Series Digital Operator Operating Manual (Manual No.: SIEP S800001 33) |
| SigmaWin+        | <b>Others - Adjust the Analog Monitor Output</b> |  ◆ Operating Procedure on page 10-13  |

- Gain Adjustment

| Tool             | Fn No./Function Name                             | Operating Procedure Reference   |
|------------------|--|---|
| Digital Operator | Fn00D  | Σ-7-Series Digital Operator Operating Manual (Manual No.: SIEP S80001 33) |
| SigmaWin+        | <b>Others - Adjust the Analog Monitor Output</b> | ◆ Operating Procedure on page 10-13                                       |

### ◆ Operating Procedure

Use the following procedure to adjust the analog monitor output.

1. Click the  Servo Drive Button in the workspace of the Main Window of the SigmaWin+.
2. Select **Adjust the Analog Monitor Output** in the Menu Dialog Box. The Adjust the Analog Monitor Output Dialog Box will be displayed.
3. Click the **Zero Adjustment** or **Gain Adjustment** Tab.

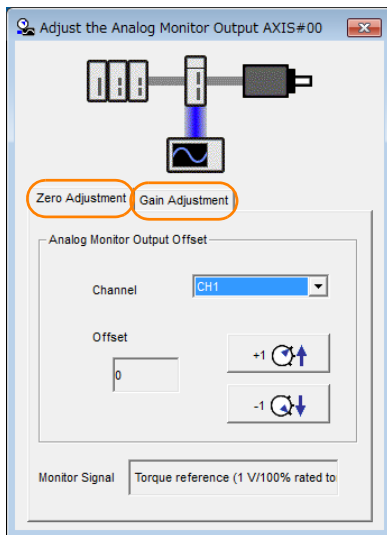



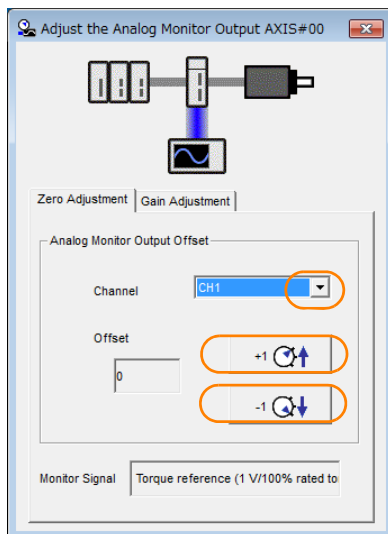

4. While watching the analog monitor, use the **+1** and **-1** Buttons to adjust the offset. There are two channels: CH1 and CH2. If necessary, click the down arrow on the **Channel** Box and select the channel.



This concludes adjusting the analog monitor output.

# 10.4 Monitoring Product Life

## 10.4.1 Items That You Can Monitor

| Monitor Item                                     | Description  |
|--|--|
| SERVOPACK Installation Environment               | The operating status of the SERVOPACK in terms of the installation environment is displayed. Implement one or more of the following actions if the monitor value exceeds 100%. <ul style="list-style-type: none"> <li>• Lower the surrounding temperature.</li> <li>• Decrease the load.</li> </ul>  |
| Servomotor Installation Environment              | The operating status of the SERVOPACK in terms of the installation environment is displayed. Implement one or more of the following actions if the monitor value exceeds 100%. <ul style="list-style-type: none"> <li>• Lower the surrounding temperature.</li> <li>• Decrease the load.</li> </ul>  |
| Built-in Fan Service Life Prediction             | The unused status of the SERVOPACK is treated as the 100% value. The value decreases each time the main circuit power supply is turned ON and each time the servo is turned OFF. Use a monitor value of 0% as a guideline for the replacement period. Refer to the following section for part replacement guidelines.<br> <a href="#">15.1.2 Guidelines for Part Replacement on page 15-2</a>   |
| Capacitor Service Life Prediction                | The unused status of the SERVOPACK is treated as the 100% value. The value decreases each time the main circuit power supply is turned ON and each time the servo is turned OFF. Use a monitor value of 0% as a guideline for the replacement period. Refer to the following section for part replacement guidelines.<br> <a href="#">15.1.2 Guidelines for Part Replacement on page 15-2</a> |
| Surge Prevention Circuit Service Life Prediction | The unused status of the SERVOPACK is treated as the 100% value. The value decreases each time the main circuit power supply is turned ON and each time the servo is turned OFF. Use a monitor value of 0% as a guideline for the replacement period. Refer to the following section for part replacement guidelines.<br> <a href="#">15.1.2 Guidelines for Part Replacement on page 15-2</a> |
| Dynamic Brake Circuit Service Life Prediction    | The unused status of the SERVOPACK is treated as the 100% value. The value decreases each time the main circuit power supply is turned ON and each time the servo is turned OFF. Use a monitor value of 0% as a guideline for the replacement period. Refer to the following section for part replacement guidelines.<br> <a href="#">15.1.2 Guidelines for Part Replacement on page 15-2</a> |
| Built-in Brake Relay Service Life Prediction     | The unused status of the built-in brake relay is treated as the 100% value. The value decreases based on the number of operations of the built-in brake relay. Use a monitor value of 0% as a guideline for the replacement period. Refer to the following section for part replacement guidelines.<br> <a href="#">15.1.2 Guidelines for Part Replacement on page 15-2</a>                   |



## 10.4.2 Operating Procedure

Use the following procedure to display the installation environment and service life prediction monitor dialog boxes.

1. Click the  Servo Drive Button in the workspace of the Main Window of the SigmaWin+.
2. Select **Life Monitor** in the Menu Dialog Box.  
The Life Monitor Dialog Box will be displayed.

**Information** With the Digital Operator, you can use Un025 to Un02A to monitor this information.

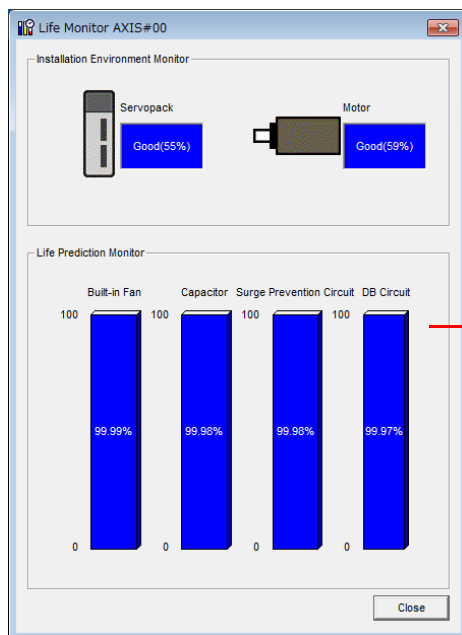

A value of 100% indicates that the SERVOPACK has not yet been used. The percentage decreases as the SERVOPACK is used and reaches 0% when it is time to replace the SERVOPACK.

## 10.4.3 Preventative Maintenance

You can use the following functions for preventative maintenance.

- Preventative maintenance warnings
- /PM (Preventative Maintenance Output) signal
- Built-in Brake Relay Life Alarm

The SERVOPACK can notify the host controller when it is time to replace any of the main parts.

### Preventative Maintenance Warning

An A.9b0 warning (Preventative Maintenance Warning) is detected when any of the following service life prediction values drops to 10% or less: SERVOPACK built-in fan life, capacitor life, inrush current limiting circuit life, dynamic brake circuit life, and built-in brake relay life. You can change the setting of Pn00F = n.□□□X to enable or disable these warnings.

| Parameter        |                             | Description                                      | When Enabled  | Classification |
|------------------|-----------------------------|--|---------------|----------------|
| Pn00F<br>(200Fh) | n.□□□0<br>(default setting) | Do not detect preventative maintenance warnings. | After restart | Setup          |
|                  | n.□□□1                      | Detect preventative maintenance warnings.        |               |                |

Note: Service life prediction of the built-in brake relay is performed as preventative maintenance for SERVOPACKs with built-in Servomotor brake control only when Pn023 is set to n.□□□0.

## /PM (Preventative Maintenance Output) Signal

The /PM (Preventative Maintenance Output) signal is output when any of the following service life prediction values reaches 10% or less: SERVOPACK built-in fan life, capacitor life, inrush current limiting circuit life, dynamic brake circuit life, and built-in brake relay life. The /PM (Preventative Maintenance Output) signal must be allocated.

Even if detection of preventive maintenance warnings is disabled (Pn00F = n.□□□0), the /PM signal will still be output as long as it is allocated.

| Classification | Signal | Connector Pin No.  | Signal Status | Description   |
|----------------|--------|--------------------|---------------|---|
| Output         | /PM    | Must be allocated. | ON (closed)   | One of the following service life prediction values reaches 10% or less: SERVOPACK built-in fan life, capacitor life, inrush current limiting circuit life, dynamic brake circuit life, and built-in brake relay life.  |
|                |        |                    | OFF (open)    | All of the following service life prediction values are greater than 10%: SERVOPACK built-in fan life, capacitor life, inrush current limiting circuit life, dynamic brake circuit life, and built-in brake relay life. |

Note: You must allocate the /PM signal to use it. The parameters that you use depend on the allocation method.

| Allocation Method                      | Parameters to Use   |
|--|---|
| Σ-7S-Compatible I/O Signal Allocations | <ul style="list-style-type: none"> <li>• Pn50A = n.□□□1 (Σ-7S-Compatible I/O Signal Allocations)</li> <li>• Pn514 = n.□X□□ (/PM (Preventative Maintenance Output) Signal Allocation)</li> </ul> |
| Multi-axis I/O signal allocations      | <ul style="list-style-type: none"> <li>• Pn50A = n.□□□2 (Multi-Axis I/O Signal Allocations)</li> <li>• Pn5BC (/PM (Preventative Maintenance Output) Signal Allocation)</li> </ul>               |

Refer to the following section for details.

 7.1.2 Output Signal Allocations on page 7-7

## Built-in Brake Relay Life Alarm

A built-in brake relay life alarm (alarm code: 232h) is detected when the number of built-in brake relay operations has exceeded 30,000 operations. You can use Pn023 = n.□□X□ to enable or disable the built-in brake relay life alarm.

| Parameter     | Description              | When Enabled  | Classification |
|---------------|--------------------------|---------------|----------------|
| Pn023 (2023h) | n.□□0□ (default setting) | After restart | Setup          |
|               | n.□□1□                   |               |                |

Note: Built-in brake relay life alarm is used as preventative maintenance for SERVOPACKs with built-in Servomotor brake control only when Pn023 is set to n.□□□0.



Replace parts immediately after the number of built-in brake relay operations has exceeded 30,000 operations.

**Important**

## 10.5 Alarm Tracing

Alarm tracing records data in the SERVOPACK from before and after an alarm occurs. This data helps you to isolate the cause of the alarm.

You can display the data recorded in the SERVOPACK as a trace waveform on the SigmaWin+.

### Information

- Alarms that occur when the power supply is turned ON are not recorded.
- Alarms that occur during the recording of alarm trace data are not recorded.
- Alarms that occur while utility functions are being executed are not recorded.
- Alarms that occur while the data tracing function of the SigmaWin+ is being executed are not recorded.

### 10.5.1 Data for Which Alarm Tracing Is Performed

Two types of data are recorded for alarm tracing: numeric data and I/O signal ON/OFF data.

| Numeric Data                  | ON/OFF Data                           |
|-------------------------------|---------------------------------------|
| Torque reference              | ALM                                   |
| Feedback speed                | Servo ON command (/S-ON)              |
| Reference speed               | Proportional control command (/P-CON) |
| Position reference speed      | Forward torque command (/P-CL)        |
| Position deviation            | Reverse torque command (/N-CL)        |
| Motor-load position deviation | G-SEL1 signal (/G-SEL1)               |
| Main circuit bus voltage      | ACON                                  |

### 10.5.2 Applicable Tools

The following table lists the tools that you can use to perform alarm tracing.

| Tool             | Fn No./Function Name   | Operating Procedure Reference   |
|------------------|--|---|
| Digital Operator | You cannot display alarm tracing data from the Digital Operator. |   |
| SigmaWin+        | <b>Troubleshooting - Alarm Trace</b>                             |  Engineering Tool SigmaWin+ Operation Manual (Manual No.: SIET S800001 34) |



# Safety Functions

# 11

This chapter provides detailed information on the safety functions of the SERVOPACK.

## **11.1 Introduction to the Safety Functions . . . . 11-3**

- 11.1.1 Safety Functions . . . . . 11-3
- 11.1.2 Precautions for Safety Functions . . . . . 11-4

## **11.2 Hard Wire Base Block (HWBB and SBB) . . 11-5**

- 11.2.1 Risk Assessment . . . . . 11-6
- 11.2.2 Hard Wire Base Block (HWBB) State . . . . . 11-7
- 11.2.3 Resetting the HWBB State . . . . . 11-8
- 11.2.4 Recovery Method . . . . . 11-9
- 11.2.5 Detecting Errors in HWBB Signal . . . . . 11-9
- 11.2.6 HWBB Input Signal Specifications . . . . . 11-10
- 11.2.7 Operation without a Host Controller . . . . . 11-10
- 11.2.8 /S-RDY (Servo Ready Output) Signal . . . . . 11-11
- 11.2.9 /BK (Brake Output) Signal . . . . . 11-11
- 11.2.10 Stopping Methods . . . . . 11-12
- 11.2.11 ALM (Servo Alarm) Signal . . . . . 11-12

## **11.3 EDM\_A and EDM\_B (External Device Monitors) . . 11-13**

- 11.3.1 EDM\_A Output Signal Specifications . . . . . 11-13

## **11.4 Applications Examples for Safety Functions . . 11-14**

- 11.4.1 Connection Example . . . . . 11-14
- 11.4.2 Failure Detection Method . . . . . 11-14
- 11.4.3 Procedure . . . . . 11-15

## **11.5 Validating Safety Functions . . . . . 11-16**

## **11.6 Connecting a Safety Function Device . . . 11-17**

**11.7 Safety Module Safety Functions . . . . . 11-18**

11.7.1 Safety Base Block with Delay (SBB-D) . . . . . 11-18  
11.7.2 Safe Position Monitor with Delay (SPM-D) . . . . . 11-19  
11.7.3 Safe Speed Limit with Delay (SLS-D) . . . . . 11-20  
11.7.4 Active Mode Function . . . . . 11-20

# 11.1 Introduction to the Safety Functions

## 11.1.1 Safety Functions

Safety functions are built into the SERVOPACK to reduce the risks associated with using the machine by protecting workers from the hazards of moving machine parts and otherwise increasing the safety of machine operation.

Especially when working in hazardous areas inside guards, such as for machine maintenance, the safety function can be used to avoid hazardous moving machine parts.

You can implement the following four safety functions depending on the Safety Module that you use.

| Function   | Description   | SERVOPACK Built-in Function | Safety Module Function   |                                    |
|--|---|-----------------------------|--------------------------|------------------------------------|
|  |   |                             |                          | Active Mode Function* <sup>1</sup> |
| Hard Wire Base Block (HWBB and SBB)                    | This safety function is equivalent to the Safety Torque OFF function defined in IEC 61800-5-2.    | Yes (HWBB)                  | Yes (SBB* <sup>2</sup> ) | –                                  |
| Safety Base Block with Delay (SBB-D)* <sup>2</sup>     | This safety function is equivalent to the Safety Stop 1 function defined in IEC 61800-5-2.        | –                           | Yes                      | Yes                                |
| Safe Position Monitor with Delay (SPM-D)* <sup>2</sup> | This safety function is equivalent to the Safety Stop 2 function defined in IEC 61800-5-2.        | –                           | Yes                      | Yes                                |
| Safe Speed Limit with Delay (SLS-D)* <sup>2</sup>      | This safety function is equivalent to the Safely-Limited Speed function defined in IEC 61800-5-2. | –                           | Yes                      | –                                  |

\*1. The Active Mode Function stops the motor according to the speed reference that is preset in a parameter in the SERVOPACK when the safety request input signal turns OFF during SBB-D or SPM-D.

The Active Mode Function is not a safety function in the compliant standards. Keep this in mind when you design the system.

Refer to the following section for details.

 [11.7.4 Active Mode Function on page 11-20](#)

\*2. A Safety Module (optional) must be connected to use this function. Refer to the following manual for application procedures.

 [Σ-V-Series/Σ-V-Series for Large-Capacity Models/Σ-7-Series User's Manual Safety Module \(Manual No.: SIEP C720829 06\)](#)

Refer to the following section for information on the safety function and safety parameters.

 [Compliance with UL Standards, EU Directives, UK Regulations, and Other Safety Standards on page xxi](#)



Important

Products that display the TÜV mark on the nameplate have met the safety standards.

---

## 11.1.2 Precautions for Safety Functions

---



### WARNING

- To confirm that the HWBB function satisfies the safety requirements of the system, you must conduct a risk assessment of the system.  
Incorrect use of the safety function may cause injury.
- The Servomotor will move if there is an external force (e.g., gravity on a vertical axis) even when the HWBB function is operating. Use a separate means, such as a mechanical brake, that satisfies the safety requirements.  
Incorrect use of the safety function may cause injury.
- While the HWBB function is operating, the motor may move within an electric angle of 180° or less as a result of a SERVOPACK failure. Use the HWBB function for an application only after confirming that movement of the motor will not result in a hazardous condition.  
Incorrect use of the safety function may cause injury.
- The dynamic brake and the brake signal are not safety-related elements. You must design the system so that SERVOPACK failures will not cause a hazardous condition while the HWBB function is operating.  
Incorrect use of the safety function may cause injury.
- Connect devices that satisfy the safety standards for the signals for safety functions.  
Incorrect use of the safety function may cause injury.
- The HWBB function does not shut OFF the power to the SERVOPACK or electrically isolate it. Implement measures to shut OFF the power supply to the SERVOPACK before you perform maintenance on it.  
There is a risk of electric shock.
- Use an SELV-compliant power supply according to EN/IEC 60950-1 to input 24 VDC to the control power supply input terminals.  
If you use a power supply that is not SELV compliant, safety functions may be lost if the power supply fails, which may result in machine damage or injury.



# 11.2 Hard Wire Base Block (HWBB and SBB)

A hard wire base block (abbreviated as HWBB) is a safety function that is designed to shut OFF the current to the motor with a hardwired circuit. The drive signals to the Power Module that controls the motor current are controlled by the circuits that are independently connected to the two input signal channels for each axis to turn OFF the Power Module and shut OFF the motor current.



**Important**

For safety function signal connections, the input signal is the 0-V common and the output signal is a source output. This is opposite to other signals described in this manual. To avoid confusion, the ON and OFF status of signals for the safety function are defined as follows:

ON: The state in which the relay contacts are closed or the transistor is ON and current flows into the signal line.

OFF: The state in which the relay contacts are open or the transistor is OFF and no current flows into the signal line.

The input signal uses the 0-V common. The following figure shows a connection example.

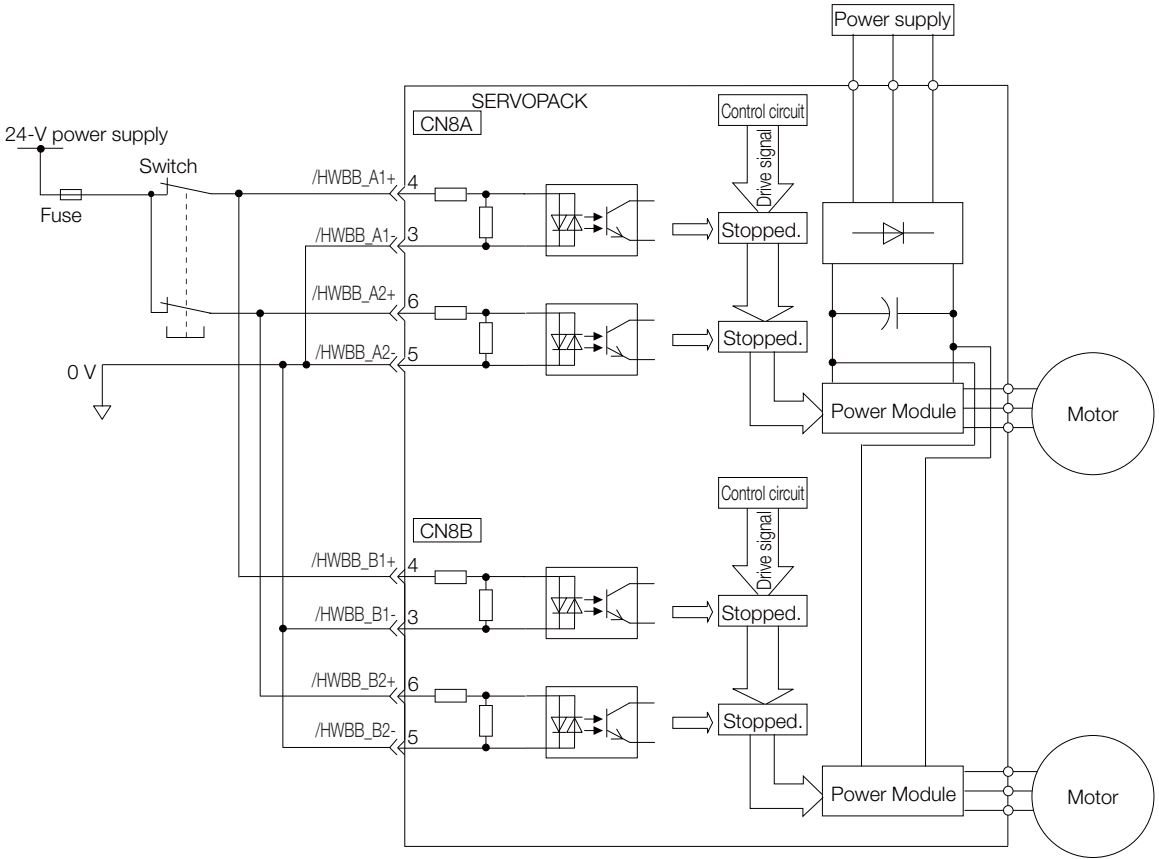

The Σ-7W SERVOPACKs have a HWBB for each axis.

If the HWBB\_A1 or HWBB\_A2 signal turns OFF, the HWBB is activated for only axis A. If the HWBB\_B1 or HWBB\_B2 signal turns OFF, the HWBB is activated for only axis B.

Chapter 10 of this manual describes mainly axis A. The corresponding connectors and signals for axis B are given in the following table.

| Axis A  | Axis B  |
|---------|---------|
| CN8A    | CN8B    |
| HWBB_A1 | HWBB_B1 |
| HWBB_A2 | HWBB_B2 |
| EDM_A   | EDM_B   |

---

## 11.2.1 Risk Assessment

---

When using the HWBB, you must perform a risk assessment of the Servo System in advance to confirm that the safety level of the standards is satisfied. Refer to the following section for details on the standards.

 *Compliance with UL Standards, EU Directives, UK Regulations, and Other Safety Standards on page xxi*

Note: To meet performance level e (PLe) in EN ISO 13849-1 and SIL3 in IEC 61508, the EDM\_A and EDM\_B signals must be monitored by the host controller. If the EDM\_A and EDM\_B signals are not monitored by the host controller, the level will be safety performance level c (PLc) and SIL1.

The following hazards exist even when the HWBB is operating. These hazards must be included in the risk assessment.

- The Servomotor will move if an external force is applied to it (for example, gravity on a vertical axis). Implement measures to hold the Servomotor, such as installing a separate mechanical brake.
- If a failure occurs such as a Power Module failure, the Servomotor may move within an electric angle of 180°. Ensure safety even if the Servomotor moves.
  - The rotational angle or travel distance depends on the type of Servomotor as follows:
    - Rotary Servomotor: 1/6 rotation max. (rotational angle calculated at the motor shaft)
    - Linear Servomotor: 50 mm max.
- The HWBB does not shut OFF the power to the SERVOPACK or electrically isolate it. Implement measures to shut OFF the power supply to the SERVOPACK before you perform maintenance on it.

# 11.2.2 Hard Wire Base Block (HWBB) State

The SERVOPACK will be in the following state if the HWBB operates. If the /HWBB\_A1 or /HWBB\_A2 signal turns OFF, the HWBB will operate and axis A will enter a HWBB state.

- **When HWBB Operates after Servo OFF (Power Not Supplied to Motor)**

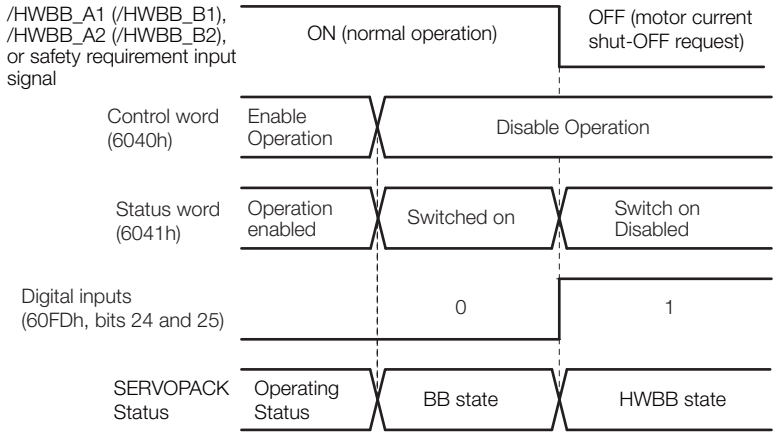

- **When HWBB Operates While Power Is Supplied to Servomotor**

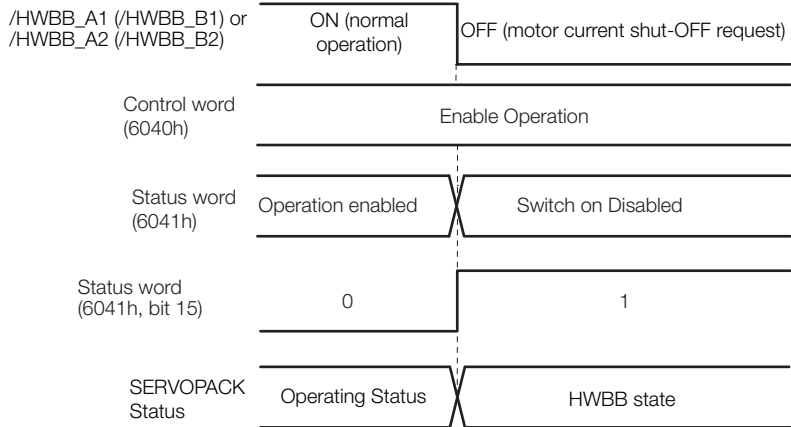

## 11.2.3 Resetting the HWBB State

Normally, if the /HWBB\_A1 or /HWBB\_A2 signal turns OFF after the Shutdown command is received and power is no longer supplied to the Servomotor, axis A will enter the HWBB state. If you turn ON the /HWBB\_A1 or /HWBB\_A2 signal in this state, the SERVOPACK will enter a base block (BB) state and will be ready to acknowledge the servo ON (Enable Operation) command.

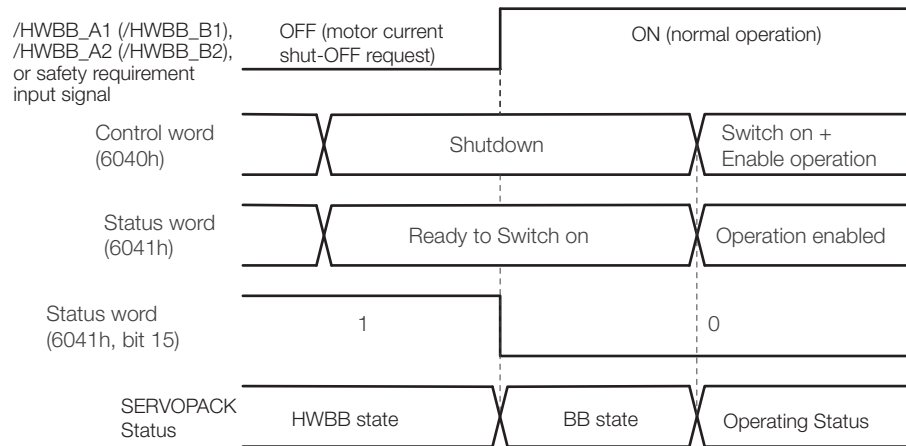

Even if the /HWBB\_A1 or /HWBB\_A2 signal is OFF and the servo ON (Enable Operation) command is received, when you turn ON the /HWBB1 and /HWBB2 signals, the SERVOPACK will enter the BB state.

Send the Servo ON command (Enable Operation command) after receiving the Shutdown command.

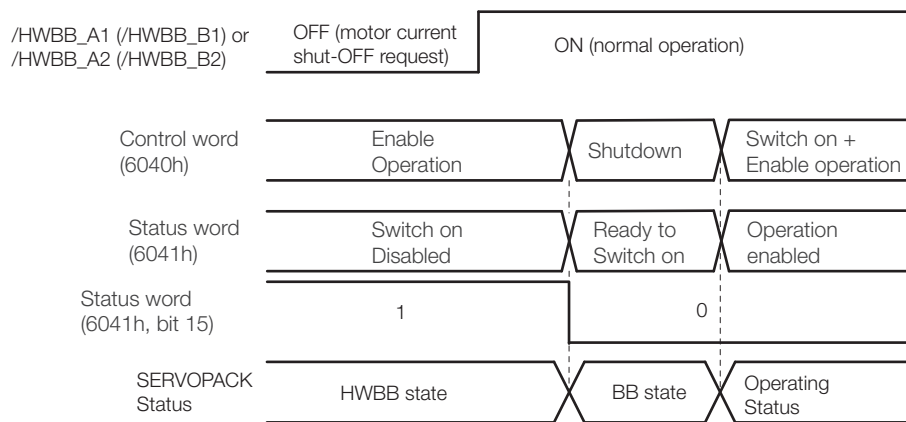

Note: If the SERVOPACK is placed in the BB state while the main circuit power supply is OFF, the HWBB state will be maintained until the Shutdown command is received.

## 11.2.4 Recovery Method

### ■ Recovery Conditions

All of the following conditions must be met.

- All safety request inputs are ON.
- The Servo ON command (Enable Operation command) was not sent.
- None of the following utility functions have been executed. (These functions execute the Servo ON command (Enable Operation command).)

The following utility functions execute the Servo ON command (Enable Operation command).

| Utility Function No. | Function Name                                  |
|----------------------|--|
| Fn002                | Jog  |
| Fn003                | Origin Search                                  |
| Fn004                | Jog Program                                    |
| Fn00E                | Autotune Motor Current Detection Signal Offset |
| Fn080                | Polarity Detection                             |
| Fn201                | Advanced Autotuning without Reference          |
| Fn206                | Easy FFT                                       |

Note: If any of the above utility functions was executed, the utility function must be ended. Perform the operation to return to the Main Menu for the utility functions on the Digital Operator. Refer to the following manual for operating procedures.

  $\Sigma$ -7-Series AC Servo Drive Digital Operator Operating Manual (Manual No.: SIEP S800001 33)

### ■ Recovery Procedure

1. Specify Shutdown in *control word* (6040h, bits 0 to 3) to reset the Servo Drive.
2. Specify Switch ON and the Servo ON command (Enable Operation command) in *control word* (6040h, bits 0 to 3).

Power will be supplied to the motor.

## 11.2.5 Detecting Errors in HWBB Signal

If only the /HWBB\_A1 or /HWBB\_A2 signal is input, an A.Eb1 alarm (Safety Function Signal Input Timing Error) will occur unless the other signal is input within 10 seconds. This makes it possible to detect failures, such as disconnection of an HWBB signal.

### CAUTION

- The A.Eb1 alarm (Safety Function Signal Input Timing Error) is not a safety-related element. Keep this in mind when you design the system.

## 11.2.6 HWBB Input Signal Specifications

If an HWBB is requested by turning OFF the /HWBB\_A1 or /HWBB\_A2 signal, the power supply to the Servomotor will be turned OFF within 8 ms.

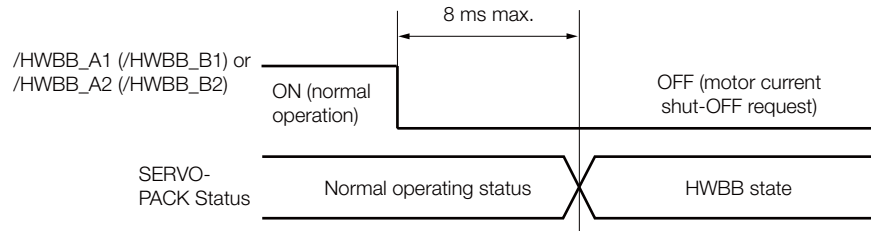

- Note: 1. The OFF status is not recognized if the OFF interval of the /HWBB\_A1 or /HWBB\_A2 signal is 0.5 ms or shorter.  
 2. You can check the status of the input signals by using monitor displays.

## 11.2.7 Operation without a Host Controller

The HWBB will operate even for operation without a host controller.

However, if the HWBB operates during execution of the following functions, leave the execution mode for the function and then enter it again to restart operation. Operation will not be restarted simply by turning ON the /HWBB\_A1 or /HWBB\_A2 signal.

| Applicable Functions  | Resetting the HWBB State   |
|---|--|
| <ul style="list-style-type: none"> <li>• Jogging</li> <li>• Origin search</li> <li>• Program jogging</li> <li>• Automatic adjustment without host reference</li> <li>• Easy FFT</li> <li>• Adjustment of motor current detection signal offset</li> </ul> | <div style="border: 1px solid black; border-radius: 10px; padding: 5px; margin-bottom: 10px; width: fit-content; margin-left: auto; margin-right: auto;">                     After you turn ON the the /HWBB_A1 (/HWBB_B1) or /HWBB_A2 (/HWBB_B2) signal leaves the execution mode for the function and then enter it again.                 </div> |

### 11.2.8 /S-RDY (Servo Ready Output) Signal

The Servo ON command (Enable Operation command) will not be acknowledged in the HWBB state. Therefore, the Servo Ready Output Signal will turn OFF. The Servo Ready Output Signal will turn ON if the /HWBB\_A1 and /HWBB\_A2 signals are ON and the servo is turned OFF (BB state).

An example is provided below for when the main circuit power supply is ON when there is no servo alarm.

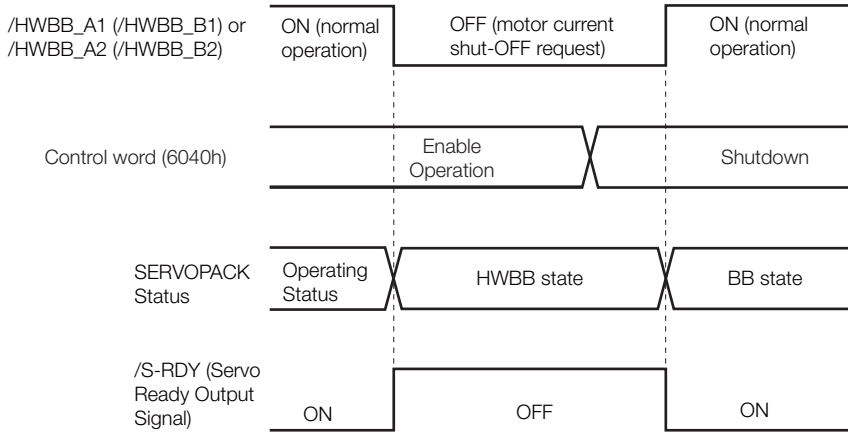

### 11.2.9 /BK (Brake Output) Signal

If the HWBB operates when the /HWBB\_A1 or /HWBB\_A2 signal is OFF, the /BK (Brake) signal will turn OFF. At that time, the setting in Pn506 (Brake Reference - Servo OFF Delay Time) will be disabled. Therefore, the Servomotor may be moved by external force until the actual brake becomes effective after the /BK signal turns OFF.

**⚠ CAUTION**

- The brake signal is not a safety-related element. You must design the system so that a hazardous condition does not occur even if the brake signal fails in the HWBB state. Also, if a Servomotor with a Brake is used, keep in mind that the brake in the Servomotor is used only to prevent the moving part from being moved by gravity or an external force and it cannot be used to stop the Servomotor.

---

## 11.2.10 Stopping Methods

---

If the /HWBB\_A1 or /HWBB\_A2 signal turns OFF and the HWBB operates, the Servomotor will stop according to the stop mode that is set for stopping the Servomotor when the servo turns OFF (Pn001 = n.□□□X). However, if the dynamic brake is enabled (Pn001 = n.□□□0 or n.□□□1), observe the following precautions.

 **CAUTION**

- The dynamic brake is not a safety-related element. You must design the system so that a hazardous condition does not occur even if the Servomotor coasts to a stop in the HWBB state. Normally, we recommend that you use a sequence that returns to the HWBB state after stopping for a reference.
- If the application frequently uses the HWBB, stopping with the dynamic brake may result in the deterioration of elements in the SERVOPACK. To prevent internal elements from deteriorating, use a sequence in which the HWBB state is returned to after the Servomotor has come to a stop.

---

## 11.2.11 ALM (Servo Alarm) Signal

---

The ALM (Servo Alarm) signal is not output in the HWBB state.



## 11.3 EDM\_A and EDM\_B (External Device Monitors)

The EDM\_A and EDM\_B (External Device Monitors) signals are used to monitor failures in the HWBB. Connect the monitor signal as a feedback signal, e.g., to the Safety Unit.

Note: To meet performance level e (PLe) in EN ISO 13849-1 and SIL3 in IEC 61508, the EDM\_A and EDM\_B signals must be monitored by the host controller. If the EDM\_A and EDM\_B signals are not monitored by the host controller, the level will be safety performance level c (Plc) and SIL1.

### Information

#### Safety Module Monitor (2720h)

You can also use *safety module monitor* (2720h) in the EtherCAT communications object dictionary to monitor the Safety Module. Refer to the following sections for details on monitoring the Safety Module.

 *Safety Module Monitor (2720h)* on page 14-27

### ◆ Failure Detection Signals for EDM\_A Signal

The relationships between the EDM\_A, /HWBB\_A1, and /HWBB\_A2 signals are shown below.

Detection of failures in the EDM\_A signal circuit can be achieved by using the four status of the EDM\_A signal in the following table. A failure can be detected by checking the failure status, e.g., when the power supply is turned ON.

#### ■ Axis A

| Signal   | Logic |     |     |     |
|----------|-------|-----|-----|-----|
| /HWBB_A1 | ON    | ON  | OFF | OFF |
| /HWBB_A2 | ON    | OFF | ON  | OFF |
| EDM_A    | OFF   | OFF | OFF | ON  |

#### ■ Axis B

| Signal   | Logic |     |     |     |
|----------|-------|-----|-----|-----|
| /HWBB_B1 | ON    | ON  | OFF | OFF |
| /HWBB_B2 | ON    | OFF | ON  | OFF |
| EDM_B    | OFF   | OFF | OFF | ON  |

## WARNING

- The EDM\_A and EDM\_B signals are not safety outputs. Use them only for monitoring for failures.

### 11.3.1 EDM\_A Output Signal Specifications

An HWBB is requested by turning OFF the two channels of /HWBB\_A1 and /HWBB\_A2 signals. If the safety function operates normally, the EDM\_A output signal will turn ON within 8 ms.

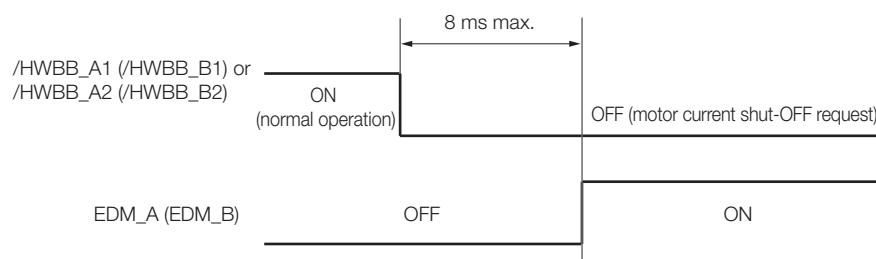

# 11.4 Applications Examples for Safety Functions

This section provides examples of using the safety functions.

## 11.4.1 Connection Example

In the following example, a Safety Unit is used and the HWBB operates when the guard is opened.

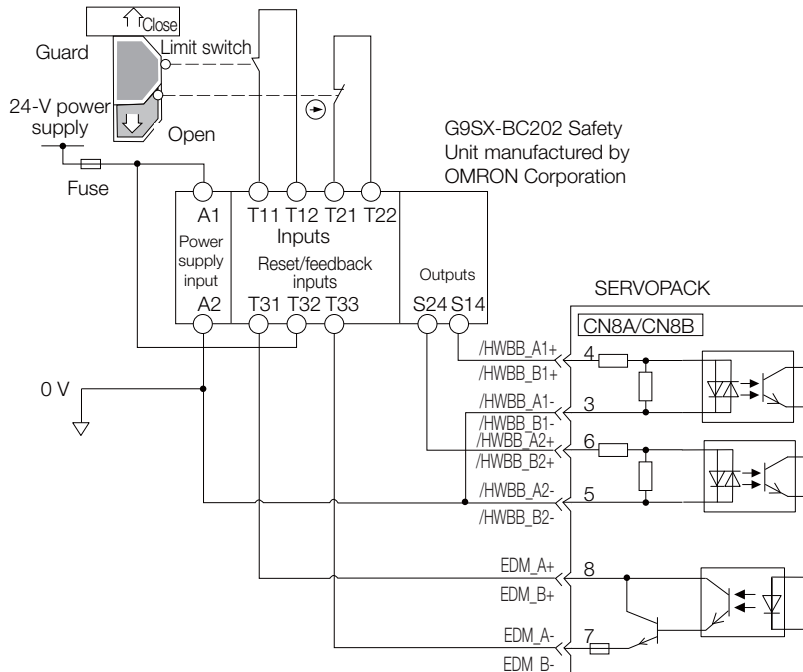

When the guard is opened, both the /HWBB\_A1 signal and /HWBB\_A2 signal turn OFF, and the EDM\_A signal turns ON. Because the feedback circuit is ON while the guard is closed, the Safety Unit is reset, the /HWBB\_A1 and /HWBB\_A2 signals turn ON, and the operation is enabled.

Note: The EDM\_A signal is used as a source output. Connect the EDM\_A so that the current flows from EMD\_A+ to EMD\_A-.

## 11.4.2 Failure Detection Method

If a failure occurs (e.g., the /HWBB\_A1 or /HWBB\_A2 signal remains ON), the Safety Unit is not reset when the guard is closed because the EDM\_A signal remains OFF. Therefore starting is not possible and a failure is detected.

In this case the following must be considered: an error in the external device, disconnection of the external wiring, short-circuiting in the external wiring, or a failure in the SERVOPACK. Find the cause and correct the problem.

---

## 11.4.3 Procedure

---

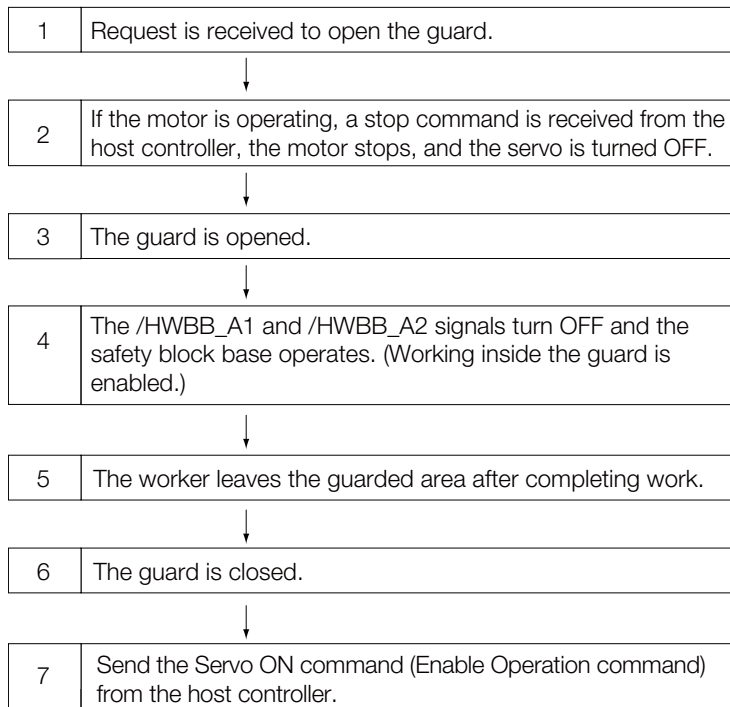

## 11.5 Validating Safety Functions

When you commission the system or perform maintenance or SERVOPACK replacement, you must always perform the following validation test on the HWBB after completing the wiring. (It is recommended that you keep the confirmation results as a record.)

- When the /HWBB\_A1 and /HWBB\_A2 signals turn OFF, confirm that the Digital Operator displays **Hbb** and that the Servomotor does not operate.
- Monitor the ON/OFF status of the /HWBB\_A1 and /HWBB\_A2 signals.  
If the ON/OFF status of the signals do not coincide with the display, the following must be considered: an error in the external device, disconnection of the external wiring, short-circuiting in the external wiring, or a failure in the SERVOPACK. Find the cause and correct the problem.
- Confirm that the EDM\_A or EDM\_B signal is OFF while in normal operation by using the feedback circuit input display of the connected device.

## 11.6 Connecting a Safety Function Device

Use the following procedure to connect a safety function device.

1. Remove the Safety Jumper Connector from the connector for the safety function device (CN8A or CN8B).

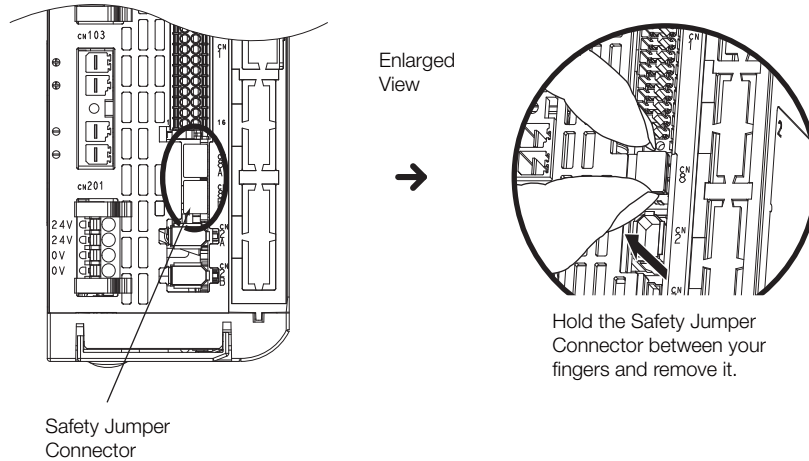

2. Connect the safety function device to the connector for the safety function device (CN8A or CN8B).

Note: If you do not connect a safety function device, leave the Safety Jumper Connector connected to the connector for the safety function device (CN8A or CN8B). If the SERVOPACK is used without the Safety Jumper Connector connected to CN8, no current will be supplied to the Servomotor and no motor torque will be output. In this case, **Hbb** will be displayed on the Digital Operator.

# 11.7 Safety Module Safety Functions

This section describes the safety functions provided by the Safety Module.

## 11.7.1 Safety Base Block with Delay (SBB-D)

The Safety Base Block with Delay (SBB-D) function operates according to the Safe Stop 1 (SS1) function defined in IEC 61800-5-2. The deceleration operation of the motor is monitored (deceleration monitoring) until the time set in a parameter elapses in response to the safety request input status. The HWBB in the SERVOPACK is then executed to shut OFF the power supply to the motor.

Note: Refer to the following manual for the application procedures for the SBB-D function.

📖  $\Sigma$ -V-Series/ $\Sigma$ -V-Series for Large-Capacity Models/ $\Sigma$ -7-Series User's Manual Safety Module (Manual No.: SIEP C720829 06)

### Operation Example for SBB-D

When the safety monitor time expires, the safe state (HWBB) is entered and then the power supply to the motor is shut OFF. The Drive enters the Switch ON Disabled state (*status word* (6041h)).

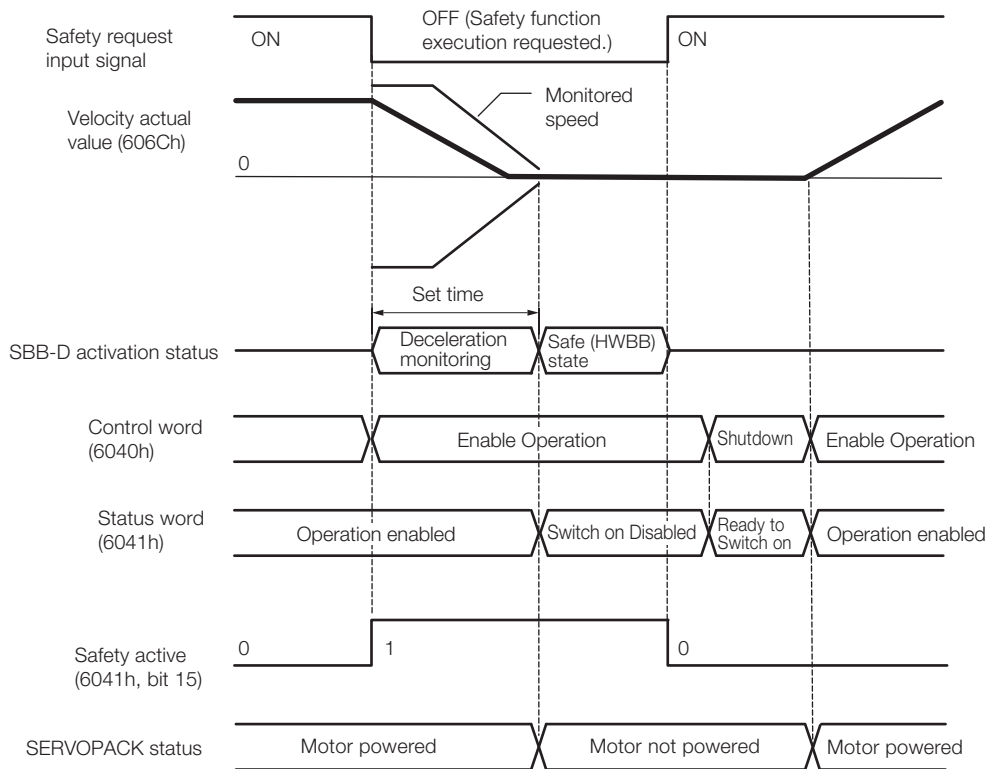

### Recovery Method

When the safety request input signal turns ON, normal operation will be enabled.

The recovery method after deceleration monitoring is completed and the safe (HWBB) state is entered is the same as for the HWBB function. Refer to the following section for details.

📖 11.2.4 Recovery Method on page 11-9

## 11.7.2 Safe Position Monitor with Delay (SPM-D)

The Safe Position Monitor with Delay (SPM-D) function operates according to the Safe Stop 2 (SS2) function defined in IEC 61800-5-2. The deceleration operation of the motor is monitored (deceleration monitoring) until the time set in a parameter elapses in response to the safety request input status. Position monitoring is then performed to see if the motor travel distance is within the allowable range.

Note: Refer to the following manual for the application procedures for the SPM-D function.

📖 [Σ-V-Series/Σ-V-Series for Large-Capacity Models/Σ-7-Series User's Manual Safety Module \(Manual No.: SIEP C720829 06\)](#)

### Operation Example for SPM-D

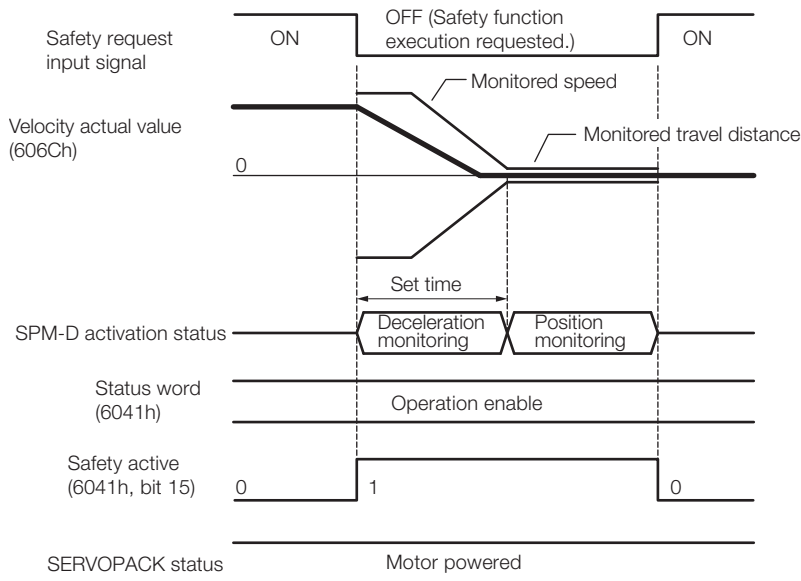

### Recovery Method

When the safety request input signal turns ON, normal operation will be enabled.

The recovery method after deceleration monitoring is completed and the safe (HWBB) state is entered is the same as for the HWBB function. Refer to the following section for details.

📖 [11.2.4 Recovery Method on page 11-9](#)

## 11.7.3 Safe Speed Limit with Delay (SLS-D)

The Safe Speed Limit with Delay (SLS-D) function operates according to the Safely-Limited Speed (SLS) function defined in IEC 61800-5-2. The deceleration operation of the motor is monitored (deceleration monitoring) until the time set in a parameter elapses in response to the safety request input status. The motor speed is then monitored to see if it is within the allowable range (within range for a constant speed).

Note: Refer to the following manual for the application procedures for the SLS-D function.

📖  $\Sigma$ -V-Series/ $\Sigma$ -V-Series for Large-Capacity Models/ $\Sigma$ -7-Series User's Manual Safety Module (Manual No.: SIEP C720829 06)

### Operation Example for SLS-D

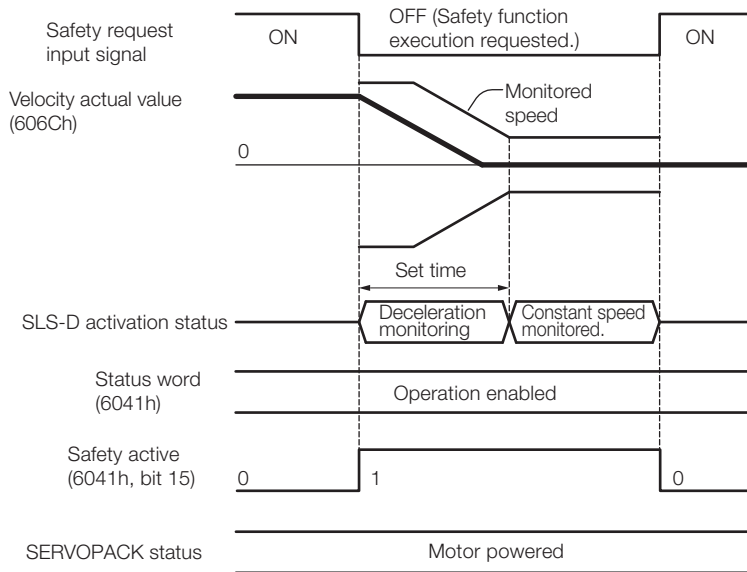

### Recovery Method

When the safety request input signal turns ON, normal operation will be enabled.

The recovery method after deceleration monitoring is completed and the safe (HWBB) state is entered in the same as for the HWBB function. Refer to the following section for details.

📖 11.2.4 Recovery Method on page 11-9

## 11.7.4 Active Mode Function

The Active Mode Function stops the motor according to the deceleration reference that is pre-set in a parameter in the SERVOPACK when the safety request input signal turns OFF during SBB-D or SPM-D.

### Active Mode Function Operation Example

If Profile Torque Mode or Cyclic Synchronous Torque Mode is set in *control word* (6040h, bits 4 to 9), the servo will be turned OFF and the motor will be stopped as soon as the safety request input signal turns OFF.



◆ When Using the SBB-D Function (Position or Speed Control)

The motor is stopped at the set deceleration rate (Pn622 or Pn623). After the deceleration monitor time (Pc11 or Pc21) elapses, the servo is turned OFF (Switch ON Disable state is entered).

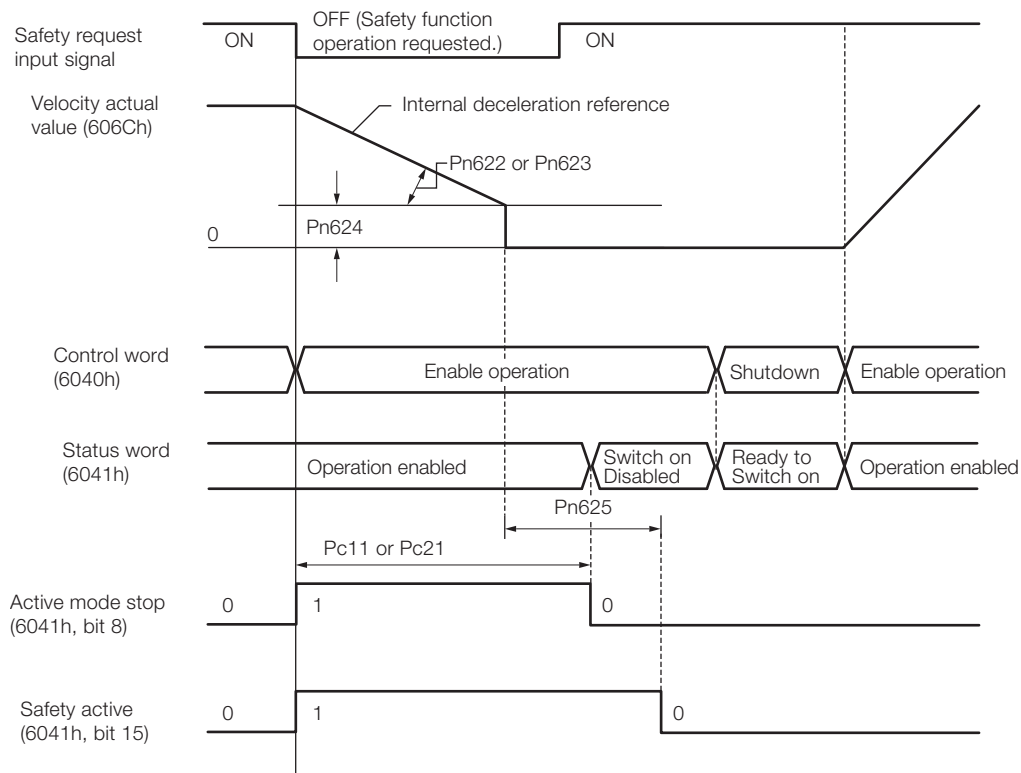

◆ When Using the SPM-D Function (Position or Speed Control)

The motor is stopped at the set deceleration rate (Pn622 or Pn623) and then the servo is locked (Operation Enabled state).

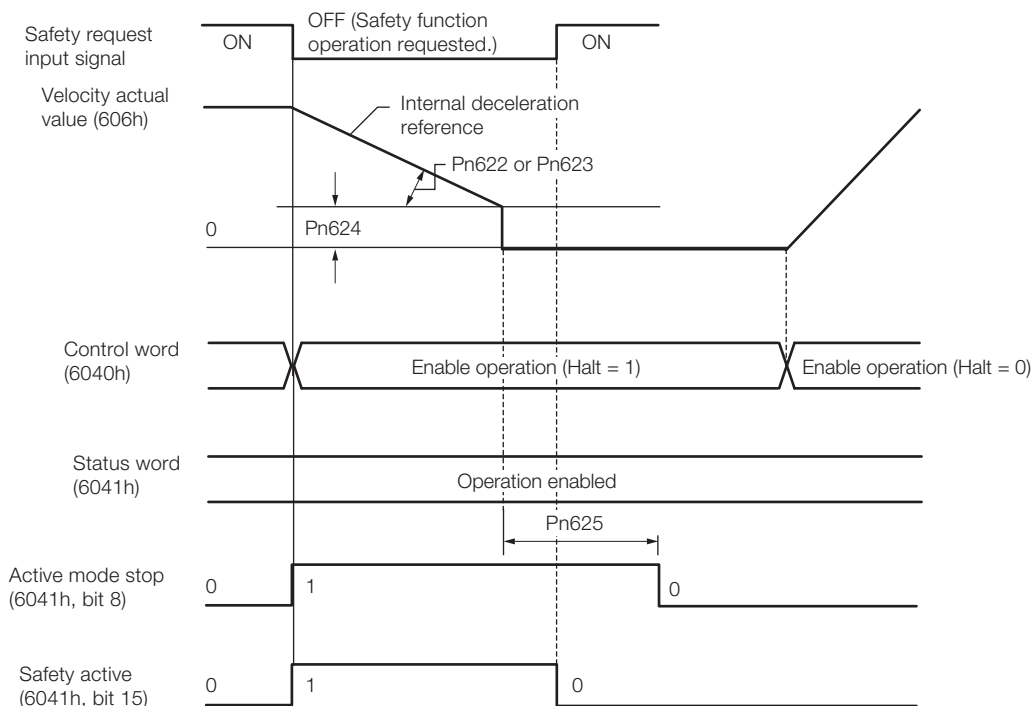

### ◆ Operation by Operation Mode When Stopped for the Active Mode Function

| Operation Mode                                   | Operation  |
|--|--|
| Profile position mode                            | Profile position operation is canceled and <i>status word</i> (6041h) changes as given below.<br>Bit 08 = 1: Active Mode Function operating.<br>Bit 12 = 0: Previous set-point already processed, waiting for new set-point.<br>Bit 15 = 1: Safety function operating.                 |
| Homing mode                                      | Homing operation is canceled and <i>status word</i> (6041h) changes as given below.<br>Bit 08 = 1: Active Mode Function operating.<br>Bit 13 = 1: Homing error.<br>Bit 15 = 1: Safety function operating.  |
| Cyclic synchronous position/velocity/torque mode | Cyclic synchronous position, velocity, or torque operation is canceled and <i>status word</i> (6041h) changes as given below.<br>Bit 08 = 1: Active Mode Function operating.<br>Bit 12 = 0: Target value (position/velocity/torque) ignored.<br>Bit 15 = 1: Safety function operating. |
| Interpolated position mode                       | Interpolated position operation is canceled and <i>status word</i> (6041h) changes as given below.<br>Bit 08 = 1: Active Mode Function operating.<br>Bit 12 = 0: Interpolation operation disabled.<br>Bit 15 = 1: Safety function operating.   |
| Profile velocity/torque mode                     | Profile velocity or torque operation is canceled and <i>status word</i> (6041h) changes as given below.<br>Bit 08 = 1: Active Mode Function operating.<br>Bit 15 = 1: Safety function operating.   |

## Recovery Method

### ◆ Recovery Conditions

If the Active Mode Function operates and the motor is stopped, the Active Mode Function will be reset and normal operation will be enabled when all of the following conditions are met.

- All relevant safety request input signals must be ON.
- A period of time equal to or greater than the value set as the Active Mode Hold Time (Pn625) must have elapsed.
- The following command must have been sent from the Controller.
- Interpolated Position Mode: Bit 8 in *control word* (6040h) = 1 (stop axis according to *halt option code* (605Dh)) or bit 4 = 0 (disable interpolation).
- Cyclic Synchronous Position/Velocity Mode or Profile Velocity Mode: Bit 8 in *control word* (6040h) = 1 (Halt).
- Profile Torque or Cyclic Synchronous Torque Mode: Bits 1 and 2 in *control word* (6040h) = 1 (Shutdown).
- Homing Mode or Profile Position Mode: No condition.

Note: If the HWBB function has turned OFF the servo, normal operation will be enabled when the corresponding safety request input signal turns ON.

### ◆ Recovery Procedure

1. After detecting that bit 8 in *status word* (6041h) is 1 (Active Mode Function operating) or that bit 15 is 1 (safety function operating), set bit 8 in *control word* (6040h) to 1 (stop axis according to *halt option code* (605Dh)).
2. After detecting that the safety request input signal turned ON, confirm that bit 8 in *status word* (6041h) is 0 (Active Mode Function operation completed) and that bit 15 is 0 (safety function operation completed), and then specify the Servo ON command (Enable Operation command) in *control word* (6040h).
3. Specify a new motion command.

# EtherCAT Communications

---

# 12

This chapter provides basic information on EtherCAT communications.

|             |   |              |
|-------------|---|--------------|
| <b>12.1</b> | <b>EtherCAT Slave Information</b>               | <b>12-2</b>  |
| <b>12.2</b> | <b>EtherCAT State Machine</b>                   | <b>12-3</b>  |
| <b>12.3</b> | <b>EtherCAT (CoE) Communications Settings</b>   | <b>12-5</b>  |
| 12.3.1      | Normal Device Recognition Process<br>at Startup | 12-5         |
| 12.3.2      | Application Example                             | 12-5         |
| 12.3.3      | Device Recognition with Station Aliases         | 12-5         |
| <b>12.4</b> | <b>PDO Mappings</b>                             | <b>12-6</b>  |
| 12.4.1      | Setting Procedure for PDO Mappings              | 12-7         |
| 12.4.2      | Default PDO Mappings                            | 12-7         |
| <b>12.5</b> | <b>Synchronization with Distributed Clocks</b>  | <b>12-8</b>  |
| <b>12.6</b> | <b>Emergency Messages</b>                       | <b>12-11</b> |

## 12.1 EtherCAT Slave Information

You can use EtherCAT slave information files (XML format) to configure the EtherCAT master. The XML file contains the standard EtherCAT communications settings for the SERVOPACK. The following file is provided for the SERVOPACK.

| SERVOPACK     | File Name                 |
|---------------|---------------------------|
| SGD7W-□□□DA0□ | Yaskawa_SGD7W-xxxDA0x.xml |

## 12.2 EtherCAT State Machine

The EtherCAT state machine is used to manage the communications states between the master and slave applications when EtherCAT communications are started and during operation, as shown in the following figure. Normally, the state changes for requests from the master.

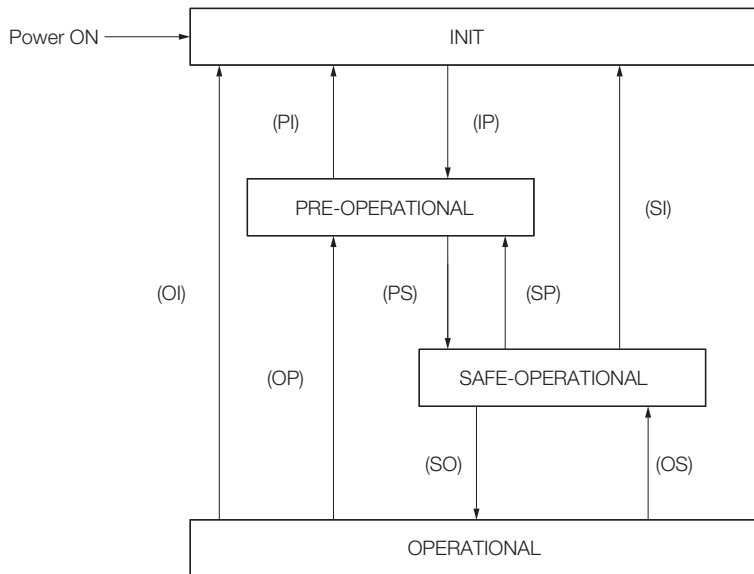

| State                     | Description  |
|---------------------------|--|
| INIT                      | <ul style="list-style-type: none"> <li>Mailbox communications are not possible.</li> <li>Process data communications are not possible.</li> </ul>  |
| INIT => PRE-OP            | <ul style="list-style-type: none"> <li>The master sets the DL address and Sync Manager channels for mailbox communications.</li> <li>The master initializes DC clock synchronization.</li> <li>The master requests the Pre-Operational state.</li> <li>The master sets the AL control register.</li> <li>The slaves check whether the mailbox was initialized correctly.</li> </ul>  |
| PRE-OPERATIONAL (PREOP)   | <ul style="list-style-type: none"> <li>Mailbox communications are possible.</li> <li>Process data communications are not possible.</li> </ul>  |
| PREOP => SAFEOP           | <ul style="list-style-type: none"> <li>The master sets the Sync Manager channels and FMMU channels for process data.</li> <li>The master uses SDOs to set the PDO mappings and the Sync Manager PDO Assignment parameters.</li> <li>The master requests the Safe-Operational state.</li> <li>The slaves check whether the Sync Manager channels for process data communications and, if required, the distributed clock settings are correct.</li> </ul> |
| SAFE-OPERATIONAL (SAFEOP) | <ul style="list-style-type: none"> <li>Mailbox communications are possible.</li> <li>Process data communications are possible. However, only the input data is valid. The output data is still not valid.</li> </ul>   |
| SAFEOP => OP              | <ul style="list-style-type: none"> <li>The master sends valid output data.</li> <li>The master requests the Operational state.</li> </ul>  |
| OPERATIONAL (OP)          | <ul style="list-style-type: none"> <li>Mailbox communications are possible.</li> <li>Process data communications are possible.</li> </ul>  |

**Information**

1. The SERVOPACK does not support EtherCAT Read/Write commands (APRW, FPRW, BRW, and LRW).
2. For SDO and PDO communications through the EtherCAT data link layer, the FMMUs and Sync Managers must be set as follows:

- Sync Manager Settings

| Sync Manager   | Assignment (Fixed)           | Size                             | Start Address (Fixed) |
|----------------|------------------------------|----------------------------------|-----------------------|
| Sync Manager 0 | Assigned to Receive Mailbox  | 128 bytes (fixed)                | 0x1000                |
| Sync Manager 1 | Assigned to Transmit Mailbox | 128 bytes (fixed)                | 0x1080                |
| Sync Manager 2 | Assigned to Receive PDOs     | 0 to 256 bytes (0 to 200 bytes*) | 0x1100                |
| Sync Manager 3 | Assigned to Transmit PDOs    | 0 to 256 bytes (0 to 200 bytes*) | 0x1400<br>(0x1358*)   |

\* This is the size and first address for a SERVOPACK with a revision number (object 1018h: 03h) of 0x00020000 or lower. This setting can also be used with a revision number (object 1018h: 03h) of 0x00030001 or higher.

- FMMU Settings

| FMMU   | Setting                              |
|--------|--------------------------------------|
| FMMU 0 | Mapped in receive PDO (RxPDO) area.  |
| FMMU 1 | Mapped in transmit PDO (TxPDO) area. |
| FMMU 2 | Mapped to the mailbox status.        |

## 12.3 EtherCAT (CoE) Communications Settings

You can use EtherCAT secondary addresses (station aliases) to identify devices or to specify addresses.

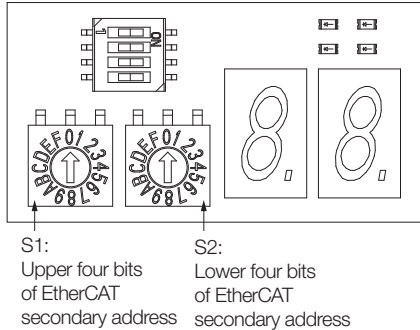

### 12.3.1 Normal Device Recognition Process at Startup

When communications are started, the master uses auto-increment addressing to detect the slaves. The Identity objects read from the slaves are compared with the master configuration information (set in advance with an EtherCAT configuration tool). Therefore, the slaves must normally be connected in the network in the same order as they appear in the master configuration. However, you can define station aliases to enable using other network topologies.

### 12.3.2 Application Example

With a machining center, there may be two identical drives for operation in the X and Y directions. When a device is replaced, there is a chance that the cable may be connected in the wrong order. To prevent the drives from receiving incorrect process data, you can use station aliases to use explicit addresses for the drives.

### 12.3.3 Device Recognition with Station Aliases

The master uses auto-increment addressing to read the station aliases. It then compares the detected station aliases with the master configuration to get the topology that was set as the network topology.

Station Alias Register (0x0012)

The station alias is set in the ESC Configured Station Alias register when the power supply is turned ON.

The value of the register can be read as follows:

$$\text{Configured station alias} = (\text{S1 set value}) \times 16 + (\text{S2 set value})$$

# 12.4 PDO Mappings

The process data that is used in process data communications is defined in the PDO mappings. PDO mappings are definitions of the applications objects that are sent with PDOs. The PDO mapping tables are in indexes 1600h to 1603h and 1610h to 1613h for the RxPDOs and indexes 1A00h to 1A03h and 1A10h to 1A13h for the TxPDOs in the object dictionary. The following figure shows an example of PDO mappings.

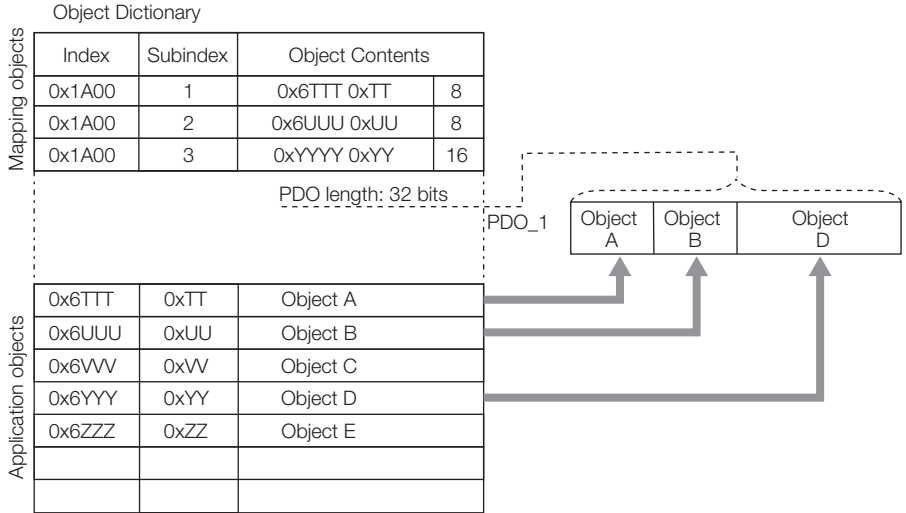

In addition to the above PDO mappings, PDOs have to be assigned to the Sync Managers to exchange EtherCAT process data. The Sync Manager PDO assignment objects (1C12h and 1C13h) establish the relationship between these PDOs and the Sync Managers.

The following figure shows an example of a Sync Manager and the PDO mappings.

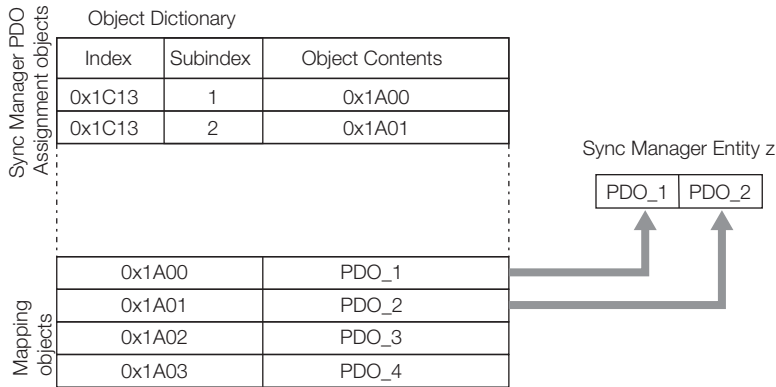

**⚠ CAUTION**

- The PDO mapping objects (indexes 1600h to 1603h, 1610h to 1613h, 1A00h to 1A03h, and 1A10h to 1A13h) and the Sync Manager PDO Assignment objects (index 1C12h and 1C13h) can be written only in Pre-Operation state.



## 12.4.1 Setting Procedure for PDO Mappings

1. Disable the assignments between the Sync Manager and PDOs.  
(Set subindex 0 of objects 1C12h to 1C13h to 0.)
2. Set all of the mapping entries for the PDO mapping objects.  
(Set objects 1600h to 1603h, 1A00h to 1A03h, 1610h to 1613h, and 1A10h to 1A13h.)
3. Set the number of mapping entries for the PDO mapping objects.  
(Set subindex 0 of objects 1600h to 1603h, 1A00h to 1A03h, 1610h to 1613h, and 1A10h to 1A13h.)
4. Set the assignments between the Sync Manager and PDOs.  
(Set subindex 1 of objects 1C12h to 1C13h.)
5. Enable the assignments between the Sync Manager and PDOs.  
(Set subindex 0 of objects 1C12h to 1C13h to 1.)

## 12.4.2 Default PDO Mappings

The following table shows the default PDO mappings for the SERVOPACK. These initial settings are also defined in the EtherCAT slave information file (XML format).

- 1st PDO Mapping (Position, Velocity, Torque, Torque Limit, and Touch Probe)

|                  |                         |                                  |                                |   |                                       |                              |                               |                                 |
|------------------|-------------------------|----------------------------------|--------------------------------|---|---------------------------------------|------------------------------|-------------------------------|---------------------------------|
| RxPDO<br>(1600h) | Control word<br>(6040h) | Target position<br>(607Ah)       | Target velocity<br>(60FFh)     | Target torque<br>(6071h)                | Max torque<br>(6072h)                 | Mode of operation<br>(6060h) | Padding<br>(8 bits)           | Touch probe function<br>(60B8h) |
| TxPDO<br>(1A00h) | Status word<br>(6041h)  | Position actual value<br>(6064h) | Torque actual value<br>(6077h) | Following error actual value<br>(60F4h) | Modes of operation display<br>(6061h) | Padding<br>(8 bits)          | Touch probe status<br>(60B9h) | Touch probe value<br>(60BAh)    |

- 2nd PDO Mapping (Cyclic Synchronous Position): Default PDO Assignments

|                  |                         |                                  |
|------------------|-------------------------|----------------------------------|
| RxPDO<br>(1601h) | Control word<br>(6040h) | Target position<br>(607Ah)       |
| TxPDO<br>(1A01h) | Status word<br>(6041h)  | Position actual value<br>(6064h) |

- 3rd PDO Mapping (Cyclic Synchronous Velocity)

|                  |                         |                                  |
|------------------|-------------------------|----------------------------------|
| RxPDO<br>(1602h) | Control word<br>(6040h) | Target velocity<br>(60FFh)       |
| TxPDO<br>(1A02h) | Status word<br>(6041h)  | Position actual value<br>(6064h) |

- 4th PDO Mapping (Cyclic Synchronous Torque)

|                  |                         |                                  |                                |
|------------------|-------------------------|----------------------------------|--------------------------------|
| RxPDO<br>(1603h) | Control word<br>(6040h) | Target torque<br>(6071h)         |                                |
| TxPDO<br>(1A03h) | Status word<br>(6041h)  | Position actual value<br>(6064h) | Torque actual value<br>(6077h) |

# 12.5 Synchronization with Distributed Clocks

The synchronization of EtherCAT communications is based on a mechanism called a distributed clock. With the distributed clock, all devices are synchronized with each other by sharing the same reference clock. The slave devices synchronize the internal applications to the Sync0 events that are generated according to the reference clock.

You can use the following synchronization modes with EtherCAT (CoE). You can change the synchronization mode in the Sync Control registers (ESC registers 0x980 and 0x981).

- Free-Run (ESC register 0x980 = 0x0000)  
In Free-Run mode, the local cycle is independent from the communications cycle and master cycle.
- DC Mode (ESC register 0x980 = 0x0300)  
In this mode, the SERVOPACK is synchronized with the host controller (master) on the Sync0 event.

The following figure gives a timing chart for DC synchronization.

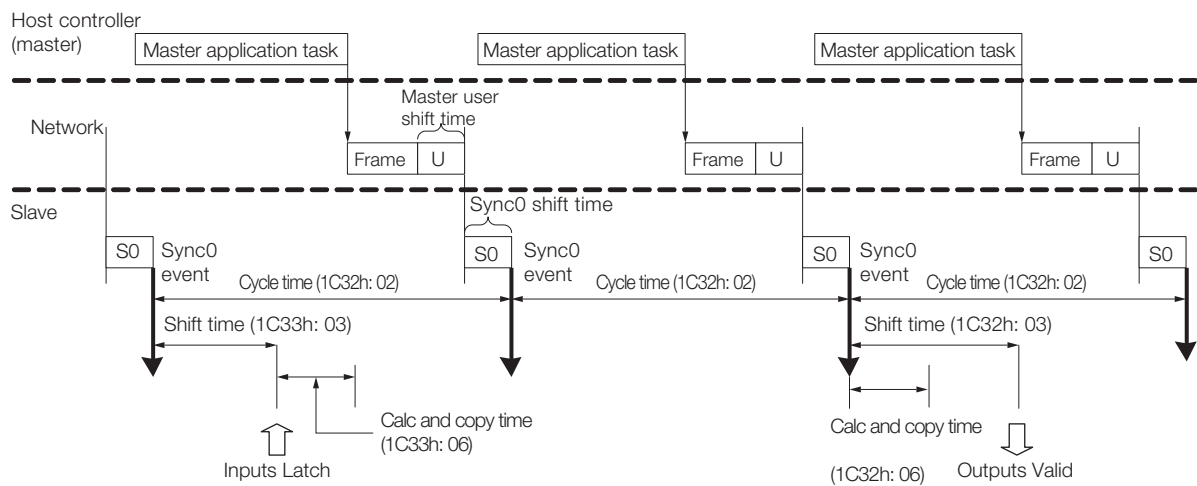

| Index  | Sub-index | Name                 | Access | PDO Mapping | Data Type | Description   |
|--|-----------|----------------------|--------|-------------|-----------|---|
| Sync Manager 2 (process data output) synchronization |           |                      |        |             |           |   |
| 1C32h  | 1         | Synchronization type | RO     | No          | UINT      | Current status of DC mode<br>0: Free-run<br>2: DC mode (synchronous with Sync0)   |
|  | 2         | Cycle time           | RO     | No          | UDINT     | Sync0 event cycle [ns]<br>(The value is set by the master via an ESC register.)<br>Range: $125,000 \times n$ ( $n = 1$ to $32$ ) [ns]   |
|  | 3         | Shift time           | RO     | No          | UDINT     | 250,000 [ns] (fixed)<br>The time between the Sync0 event and Outputs Valid (i.e., the time from Sync0 until the output data is input to the SERVOPACK).   |
|  | 6         | Calc and copy time   | RO     | No          | UDINT     | 62,500 [ns] (fixed)<br>The time from the Sync0 event until the output data from Sync Manager 2 is read.   |
| Sync Manager 3 (process data input) synchronization  |           |                      |        |             |           |   |
| 1C33h  | 3         | Shift time           | RW     | No          | UDINT     | $125,000 \times n$ ( $n = 1$ to $32$ ) [ns]<br>Range: 0 to (Sync0 event cycle - 12,500) [ns]<br>The time between the Sync0 event and Inputs Latch (i.e., when the input data is obtained from the SERVOPACK). |
|  | 6         | Calc and copy time   | RO     | No          | UDINT     | 62,500 [ns] (fixed)<br>The time for copying the input process data to the Sync Manager 3 area.  |

### Example of PDO Data Exchange Timing in DC Mode

- DC Cycle Time = 1 ms, Input Shift Time = 500  $\mu$ s

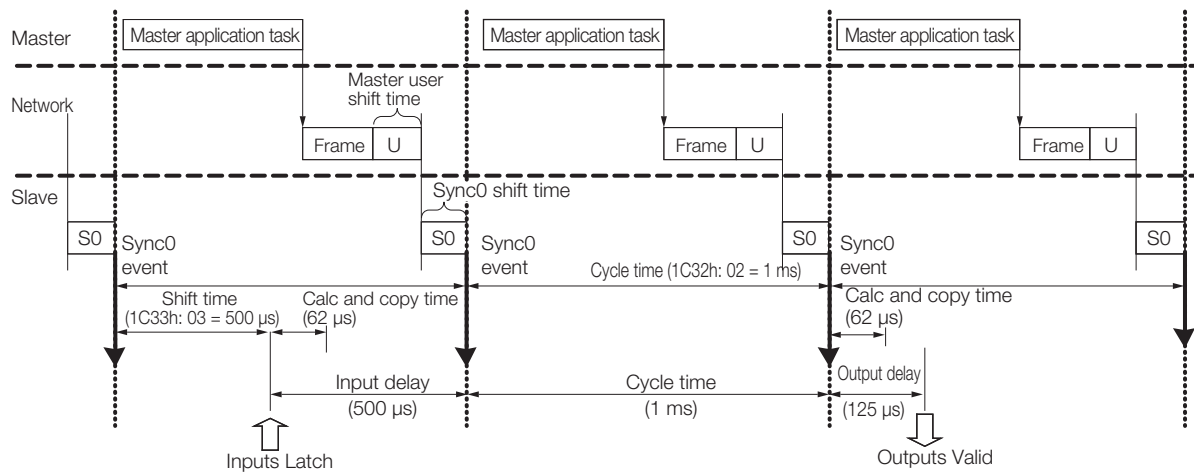

- DC Cycle Time = 125  $\mu$ s, Input Shift Time = 0  $\mu$ s

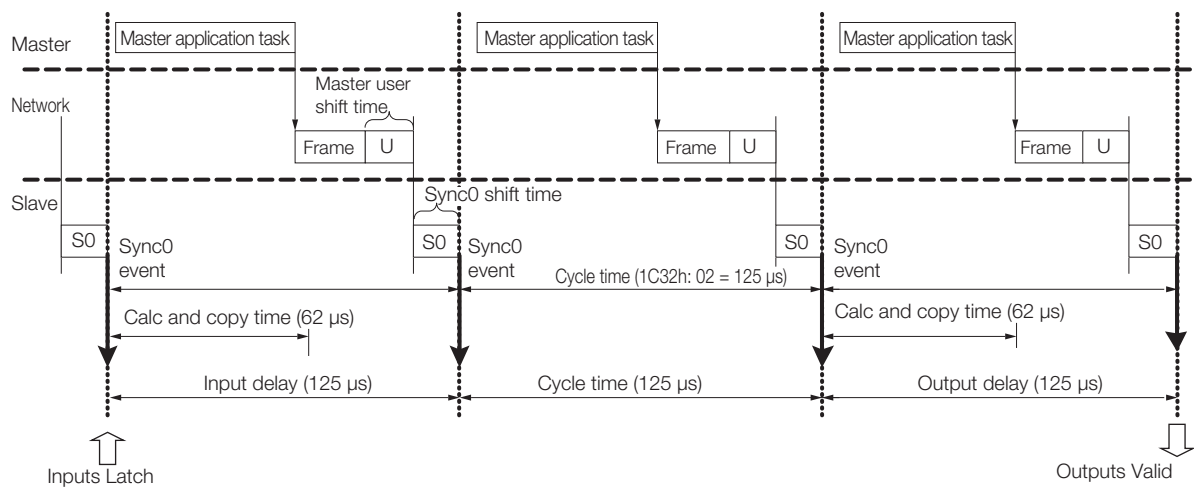

## 12.6 Emergency Messages

Emergency messages are triggered by alarms and warnings detected within the SERVOPACK. They are sent via the mailbox interface.

An emergency message consists of eight bytes of data as shown in the following table.

| Byte        | 0  | 1 | 2                             | 3         | 4  | 5         | 6                      | 7 |
|-------------|--|---|-------------------------------|-----------|--|-----------|------------------------|---|
| Description | Emergency error code (FF00h)* <sup>1</sup> |   | Error register (object 1001h) | Reserved. | Manufacturer-specific error field          |           |                        |   |
|             |  |   |                               |           | SERVOPACK alarm/warning code* <sup>2</sup> | Reserved. | Axis No.* <sup>2</sup> |   |

\*1. The manufacturer-specific error code is always FF00h.

\*2. For details on SERVOPACK alarms and warnings, refer to the following sections.

 *Chapter 15 Maintenance*



# CiA402 Drive Profile

13

|             |                                  |              |
|-------------|----------------------------------|--------------|
| <b>13.1</b> | <b>Device Control</b>            | <b>13-3</b>  |
| 13.1.1      | State Machine Control Commands   | 13-4         |
| 13.1.2      | Bits in Status word              | 13-4         |
| 13.1.3      | Related Objects                  | 13-4         |
| <b>13.2</b> | <b>Modes of Operation</b>        | <b>13-5</b>  |
| 13.2.1      | Related Objects                  | 13-5         |
| 13.2.2      | Dynamic Mode Changes             | 13-5         |
| <b>13.3</b> | <b>Position Control Modes</b>    | <b>13-6</b>  |
| 13.3.1      | Profile Position Mode            | 13-6         |
| 13.3.2      | Interpolated Position Mode       | 13-9         |
| 13.3.3      | Cyclic Synchronous Position Mode | 13-12        |
| <b>13.4</b> | <b>Homing</b>                    | <b>13-14</b> |
| 13.4.1      | Related Objects                  | 13-14        |
| 13.4.2      | Homing Method                    | 13-14        |
| <b>13.5</b> | <b>Velocity Control Modes</b>    | <b>13-17</b> |
| 13.5.1      | Profile Velocity Mode            | 13-17        |
| 13.5.2      | Cyclic Synchronous Velocity Mode | 13-18        |
| <b>13.6</b> | <b>Torque Control Modes</b>      | <b>13-19</b> |
| 13.6.1      | Profile Torque Mode              | 13-19        |
| 13.6.2      | Cyclic Sync Torque Mode          | 13-20        |
| <b>13.7</b> | <b>Torque Limits</b>             | <b>13-21</b> |

**13.8 Digital I/O Signals . . . . . 13-22**

**13.9 Touch Probe . . . . . 13-23**

13.9.1 Related Objects . . . . . 13-23

13.9.2 Example of Execution Procedure  
for a Touch Probe . . . . . 13-24



# 13.1 Device Control

You use the *control word* (6040h) to execute device control for the Servo Drive according to the following state transitions. You can use the *status word* (6041h) to monitor the device status of the Servo Drive.

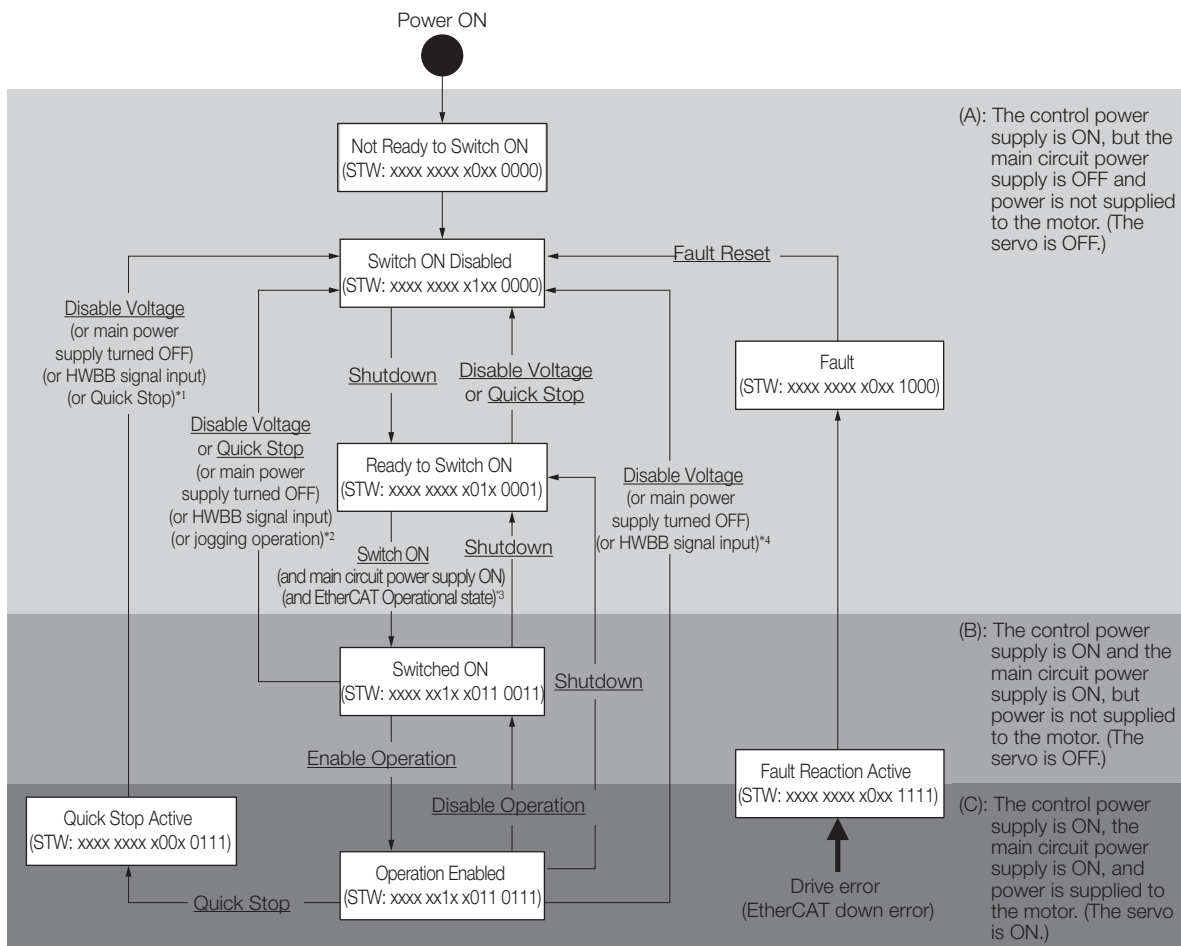

- \*1. In the Quick Stop Active state, the SERVOPACK automatically moves to the Switch ON Disabled state in the following cases:
- The main power supply was turned OFF.
  - The HWBB signal was input.
  - The motor was stopped.
- \*2. In the Switched ON state, the SERVOPACK automatically moves to the Switch ON Disabled state in the following cases:
- The main power supply was turned OFF.
  - The HWBB signal was input.
  - Motor operation was already enabled by the Digital Operator or the SigmaWin+.
- \*3. In the Ready to Switch ON state, the SERVOPACK moves to the next state in the following cases:
- The main circuit power supply is ON.
  - The EtherCAT state machine (ESM) is in the Operational state.
  - The Servomotor is not being operated by the Digital Operator or the SigmaWin+.
- \*4. In the Operation Enabled state, the SERVOPACK automatically moves to the Switch ON Disabled state in the following cases:
- The main power supply was turned OFF.
  - The HWBB signal was input.

Note: 1.  : The states are shown in white boxes.

2. STW indicates the *status word* (6041h).

3. \_\_\_\_\_: Underlines indicate control commands in the *control word* (6040h).

## 13.1.1 State Machine Control Commands

| Command                      | Bits in Control word (6040h) |       |       |       |       |
|------------------------------|------------------------------|-------|-------|-------|-------|
|                              | Bit 7                        | Bit 3 | Bit 2 | Bit 1 | Bit 0 |
| Shutdown                     | 0                            | –     | 1     | 1     | 0     |
| Switch ON                    | 0                            | 0     | 1     | 1     | 1     |
| Switch ON + Enable Operation | 0                            | 1     | 1     | 1     | 1     |
| Disable Voltage              | 0                            | –     | –     | 0     | –     |
| Quick Stop                   | 0                            | –     | 0     | 1     | –     |
| Disable Operation            | 0                            | 0     | 1     | 1     | 1     |
| Enable Operation             | 0                            | 1     | 1     | 1     | 1     |
| Fault Reset                  | 0 → 1                        | –     | –     | –     | –     |

## 13.1.2 Bits in Status word

| Bit | Data Description        | Remarks  |
|-----|-------------------------|--|
| 0   | Ready to Switch ON      | Refer to the following section for details.<br> 14.7 Device Control on page 14-28 |
| 1   | Switched ON             |  |
| 2   | Operation Enabled       |  |
| 3   | Fault                   |  |
| 4   | Voltage Enabled         |  |
| 5   | Quick Stop              |  |
| 6   | Switch ON Disabled      |  |
| 7   | Warning                 |  |
| 8   | Active Mode Stop        |  |
| 9   | Remote                  |  |
| 10  | Target Reached          |  |
| 11  | Internal Limit Active   |  |
| 12  | Operation Mode Specific |  |
| 13  |                         |  |
| 14  | Torque Limit Active     |  |
| 15  | Safety Active           |  |

## 13.1.3 Related Objects

| Index | Subindex | Name                          | Access | PDO Mapping | Unit | Data Type |
|-------|----------|-------------------------------|--------|-------------|------|-----------|
| 6040h | 0        | Control word                  | RW     | Yes         | –    | UINT      |
| 6041h | 0        | Status word                   | RO     | Yes         | –    | UINT      |
| 605Ah | 0        | Quick stop option code        | RW     | No          | –    | INT       |
| 605Bh | 0        | Shutdown option code          | RW     | No          | –    | INT       |
| 605Ch | 0        | Disable operation option code | RW     | No          | –    | INT       |
| 605Dh | 0        | Halt option code              | RW     | No          | –    | INT       |
| 605Eh | 0        | Fault reaction option code    | RW     | No          | –    | INT       |

## 13.2 Modes of Operation

The SERVOPACK supports the following modes of operation.

- Profile Position Mode
- Homing Mode
- Interpolated Position Mode
- Profile Velocity Mode
- Torque Profile Velocity Mode
- Cyclic Sync Position Mode
- Cyclic Sync Velocity Mode
- Cyclic Sync Torque Mode

### 13.2.1 Related Objects

| Index | Subindex | Name                       | Access | PDO Mapping | Unit | Data Type |
|-------|----------|----------------------------|--------|-------------|------|-----------|
| 6060h | 0        | Modes of operation         | RW     | Yes         | –    | SINT      |
| 6061h | 0        | Modes of operation display | RO     | Yes         | –    | SINT      |
| 6502h | 0        | Supported drive modes      | RO     | No          | –    | UDINT     |

### 13.2.2 Dynamic Mode Changes

You can change the operation mode with *modes of operation* (6060h). The master must update all operation mode-specific process data objects at the same time when it changes the operation mode during motor operation. If the master selects a new operation mode, the SERVOPACK will change to the new operation mode immediately. The following table describes operation when the operation mode is changed to a new mode.

| New Operation Mode           | Operation When Operation Mode Is Changed  |
|------------------------------|---|
| Profile Position Mode        | Control word bit 4 = 0: The motor is stopped in the current position control mode.<br>Control word bit 4 = 1: A new positioning operation is started immediately. |
| Homing Mode                  | Control word bit 4 = 0: The motor is stopped in the current position control mode.<br>Control word bit 4 = 1: Homing is started immediately.                      |
| Interpolated Position Mode   | Control word bit 4 = 0: The motor is stopped in the current position control mode.<br>Control word bit 4 = 1: A new positioning operation is started immediately. |
| Profile Velocity Mode        | The new operation mode is started immediately.  |
| Torque Profile Velocity Mode | The new operation mode is started immediately.  |
| Cyclic Sync Position Mode    | The new operation mode is started immediately.  |
| Cyclic Sync Velocity Mode    | The new operation mode is started immediately.  |
| Cyclic Sync Torque Mode      | The new operation mode is started immediately.  |

# 13.3 Position Control Modes

## 13.3.1 Profile Position Mode

The Profile Position Mode is used to position to the target position at the profile velocity and the profile acceleration.

The following figure shows the block diagram for the Profile Position Mode.

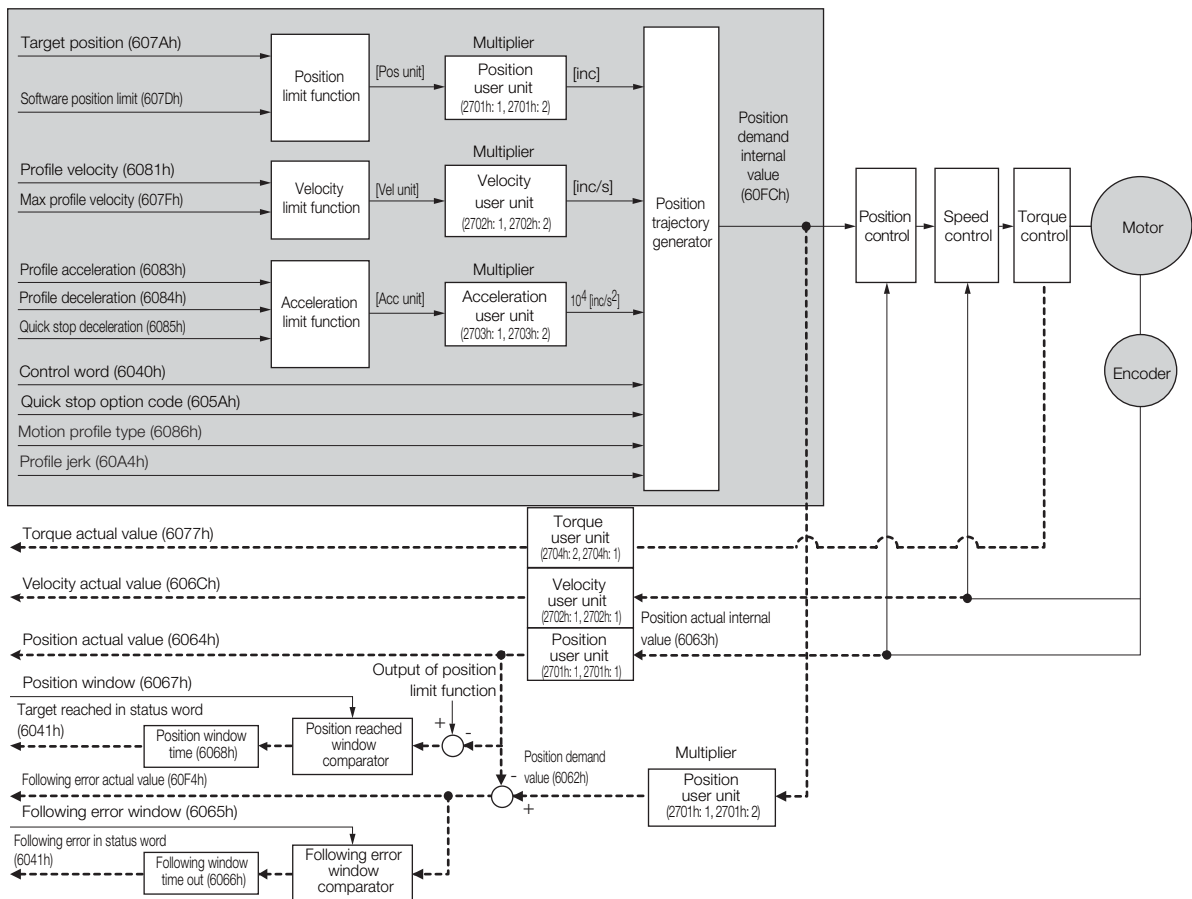

### Related Objects

| Index | Subindex                | Name                    | Access | PDO Mapping | Unit     | Data Type |
|-------|-------------------------|-------------------------|--------|-------------|----------|-----------|
| 6040h | 0                       | Control word            | RW     | Yes         | -        | UINT      |
| 6041h | 0                       | Status word             | RO     | Yes         | -        | UINT      |
| 607Ah | 0                       | Target position         | RW     | Yes         | Pos unit | DINT      |
| 607Dh | Software position limit |                         |        |             |          |           |
|       | 1                       | Min position limit      | RW     | No          | Pos unit | DINT      |
|       | 2                       | Max position limit      | RW     | No          | Pos unit | DINT      |
| 607Fh | 0                       | Max profile velocity    | RW     | Yes         | Vel unit | UDINT     |
| 6081h | 0                       | Profile velocity        | RW     | Yes         | Vel unit | UDINT     |
| 6083h | 0                       | Profile acceleration    | RW     | Yes         | Acc unit | UDINT     |
| 6084h | 0                       | Profile deceleration    | RW     | Yes         | Acc unit | UDINT     |
| 6085h | 0                       | Quick stop deceleration | RW     | Yes         | Acc unit | UDINT     |
| 6086h | -                       | Motion profile type     | RW     | Yes         | -        | INT       |
| 60A4h | Profile jerk            |                         |        |             |          |           |
|       | 1                       | Profile jerk 1          | RW     | No          | %        | UDINT     |

In the Profile Position Mode, the following two methods can be used to start positioning.

#### ◆ Single Set Point (When Change Set Immediately Bit (Bit 5) in *Control word* Is 1)

When a new command is input to the New Set Point bit (bit 4) in *control word* during positioning, positioning for the new command is started immediately.

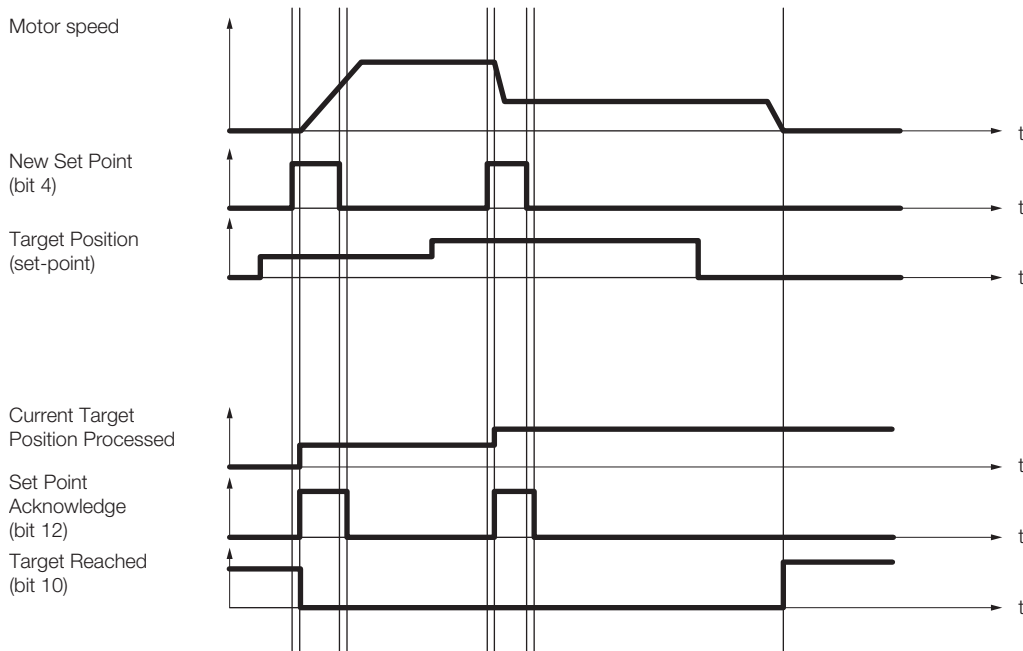

#### ◆ Set of Set Points (When Change Set Immediately Bit (Bit 5) in *Control word* Is 0)

When a new command is input in the New Set Point bit (bit 4) in *control word* during positioning, positioning for the new command is started as soon as the current positioning operation is completed. The dotted line in the following figure shows the actual speed if the Change of Set Point bit (bit 9) is set to 1.

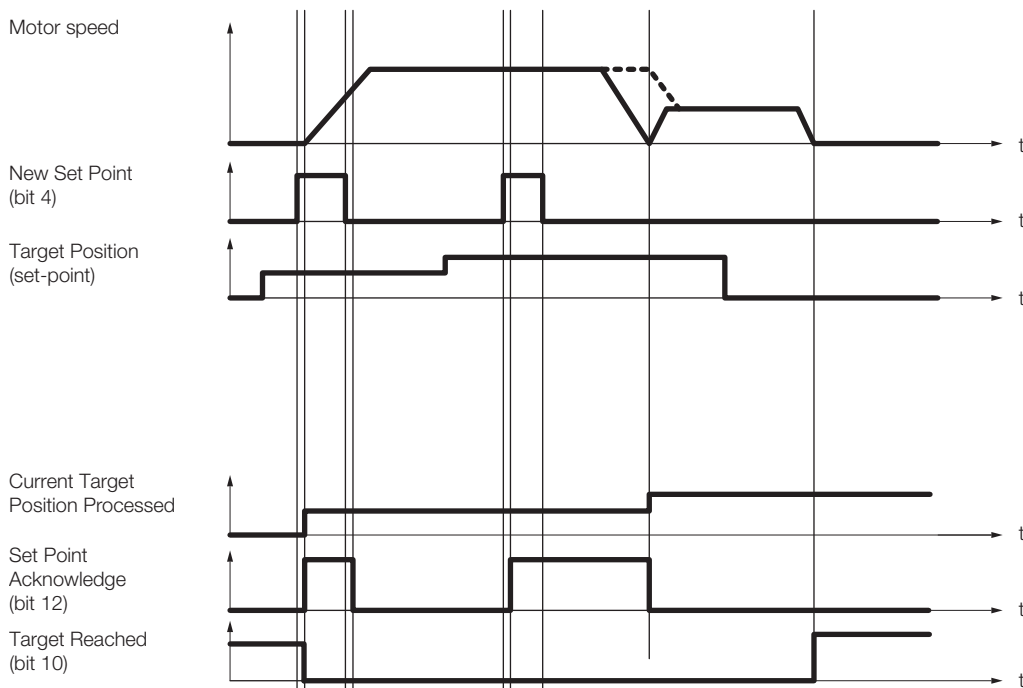

◆ SPOSING (S-curve Acceleration/Deceleration Positioning)

If you set *Motion profile type* to 2, S-curve acceleration/deceleration will be used for positioning to *Target position*.

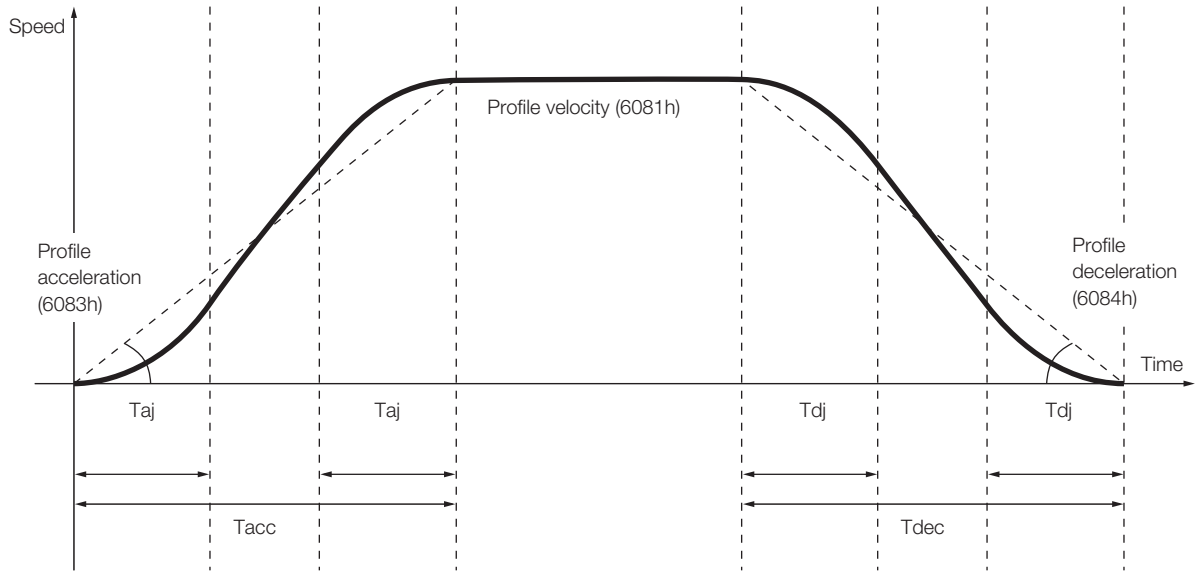

Acceleration time:  $T_{acc} = \frac{\text{Profile velocity (6081h)}}{\text{Profile acceleration (6083h)}}$

S-curve acceleration time:  $T_{aj} = T_{acc} \times \text{Profile jerk (60A4h)}$

Deceleration time:  $T_{dec} = \frac{\text{Profile velocity (6081h)}}{\text{Profile deceleration (6084h)}}$

S-curve deceleration time:  $T_{dj} = T_{dec} \times \text{Profile jerk (60A4h)}$



Important

1. If you change the *Target position (607Ah)*, *Profile velocity (6081h)*, *Profile acceleration (6083h)*, or *Profile deceleration (6084h)*, do so either while positioning is stopped or while positioning at a constant speed.
2. Set the S-curve acceleration/deceleration time in *Profile jerk (60A4h)*.

## 13.3.2 Interpolated Position Mode

The Interpolated Position Mode is used to control multiple coordinated axes or to control a single axis that requires time interpolation of the set point data. There are the following two sub-modes for the Interpolated Position Mode.

*Interpolation submode select* (60C0h) is used to change the submode. Refer to the following section for details.

 14.11 Interpolated Position Mode on page 14-42

| Interpolated Position Mode |                              | Number of Data | Number of Profiles |
|----------------------------|------------------------------|----------------|--------------------|
| Mode 1                     | No position reference filter | 1              | 1                  |
|                            | Position reference filter    |                |                    |
| Mode 2                     | No position reference filter | 1 to 254       | 2                  |
|                            | Position reference filter    |                |                    |

### Mode 1

This submode normally uses a time (communications) synchronization mechanism to synchronize the Servo Drives. The Interpolation Time Period defines the update cycle of the Interpolation Data (i.e., the interpolation position). The interpolation processing in the SERVOPACK is based on this setting. The Interpolation Data is interpreted as an absolute value.

The following figure shows the block diagram for mode 1.

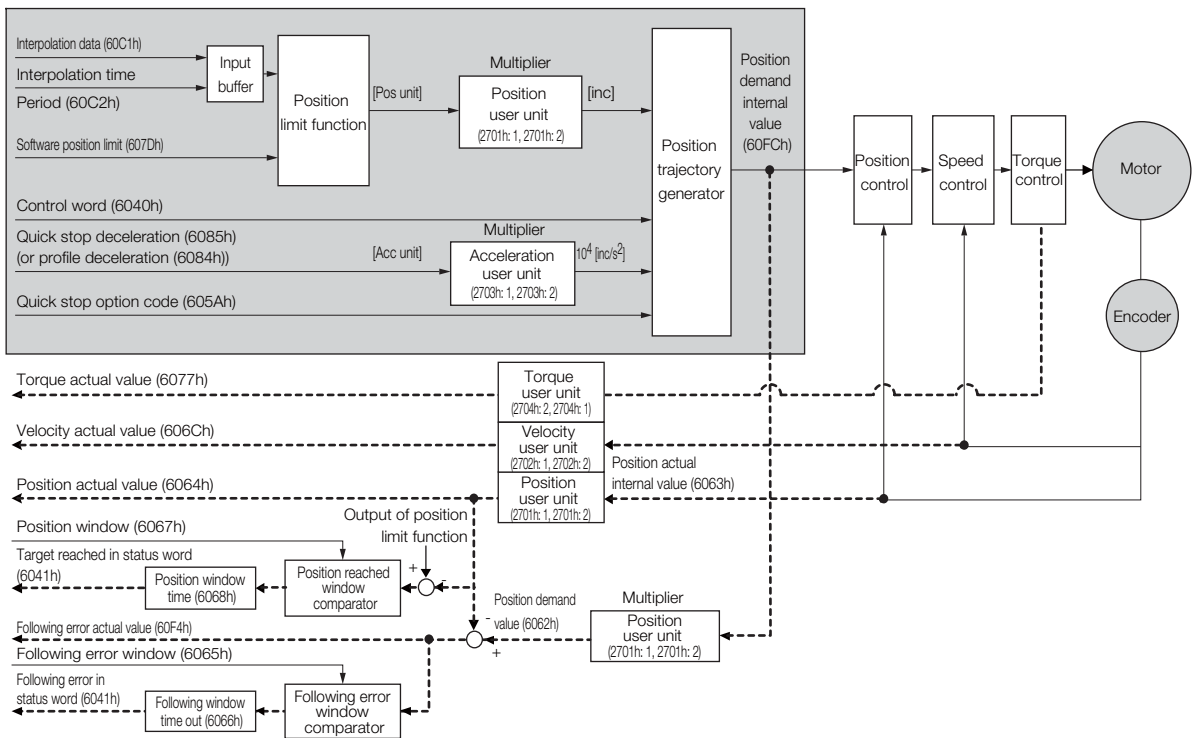

◆ Related Objects

| Index | Subindex                  | Name                            | Access | PDO Mapping | Unit     | Data Type |
|-------|---------------------------|---------------------------------|--------|-------------|----------|-----------|
| 6040h | 0                         | Control word                    | RW     | Yes         | –        | UINT      |
| 6041h | 0                         | Status word                     | RO     | Yes         | –        | UINT      |
| 60C1h | 1                         | Interpolation data record       | RW     | Yes         | Pos unit | DINT      |
| 60C2h | Interpolation time period |                                 |        |             |          |           |
|       | 1                         | Interpolation time period value | RW     | No          | –        | USINT     |
|       | 2                         | Interpolation time index        | RW     | No          | –        | SINT      |
| 607Dh | Software position limit   |                                 |        |             |          |           |
|       | 1                         | Min position limit              | RW     | No          | Pos unit | DINT      |
|       | 2                         | Max position limit              | RW     | No          | Pos unit | DINT      |
| 6084h | 0                         | Profile deceleration            | RW     | Yes         | Acc unit | UDINT     |
| 6085h | 0                         | Quick stop deceleration         | RW     | Yes         | Acc unit | UDINT     |

Mode 2

This submode is used to perform interpolation feeding control for an individual axis. Unlike mode 1, mode 2 has reference input buffers (*interpolation data record for 1st profile* and *interpolation data record for 2nd profile*) that you can set to different interpolation positions (*interpolation data record*). The interpolation positions that are set in the reference input buffers are read each *interpolation time period* to perform interpolation processing.

The following figure shows the block diagram for mode 2.

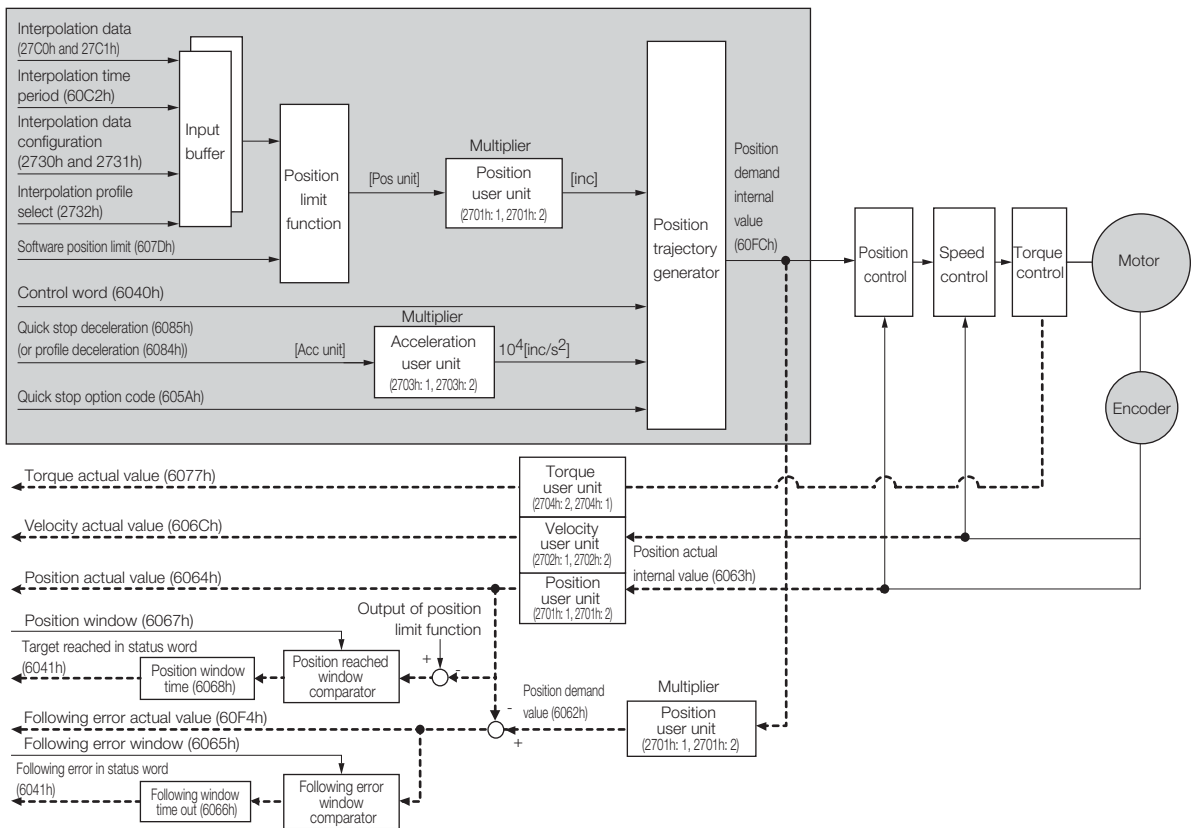



## ◆ Related Objects

| Index | Subindex   | Name  | Access | PDO Mapping | Unit     | Data Type |
|-------|--|---|--------|-------------|----------|-----------|
| 6040h | 0  | Control word  | RW     | Yes         | –        | UINT      |
| 6041h | 0  | Status word   | RO     | Yes         | –        | UINT      |
| 60C2h | Interpolation time period                              |   |        |             |          |           |
|       | 1  | Interpolation time period value                       | RW     | No          | –        | USINT     |
|       | 2  | Interpolation time index                              | RW     | No          | –        | SINT      |
| 2730h | Interpolation data configuration for 1st profile       |   |        |             |          |           |
|       | 1  | Maximum buffer size                                   | RO     | No          | –        | UDINT     |
|       | 2  | Actual buffer size                                    | RW     | No          | –        | UDINT     |
|       | 3  | Buffer organization                                   | RW     | No          | –        | USINT     |
|       | 4  | Buffer position                                       | RW     | Yes         | –        | UINT      |
|       | 5  | Size of data record                                   | WO     | No          | –        | USINT     |
|       | 6  | Buffer clear  | WO     | No          | –        | USINT     |
|       | 7  | Position data definition                              | RW     | Yes         | –        | USINT     |
|       | 8  | Position data polarity                                | RW     | Yes         | –        | USINT     |
| 9     | Behavior after reaching buffer position                | RW  | Yes    | –           | USINT    |           |
| 2731h | Interpolation data configuration for 2nd profile       |   |        |             |          |           |
|       | 1  | Maximum buffer size                                   | RO     | No          | –        | UDINT     |
|       | 2  | Actual buffer size                                    | RW     | No          | –        | UDINT     |
|       | 3  | Buffer organization                                   | RW     | No          | –        | USINT     |
|       | 4  | Buffer position                                       | RW     | Yes         | –        | UINT      |
|       | 5  | Size of data record                                   | WO     | No          | –        | USINT     |
|       | 6  | Buffer clear  | WO     | No          | –        | USINT     |
|       | 7  | Position data definition                              | RW     | Yes         | –        | USINT     |
|       | 8  | Position data polarity                                | RW     | Yes         | –        | USINT     |
| 9     | Behavior after reaching buffer position                | RW  | Yes    | –           | USINT    |           |
| 2732h | 0  | Interpolation profile select                          | RW     | Yes         | –        | USINT     |
| 27C0h | 1-254  | Interpolation data record for 1 <sup>st</sup> profile | RW     | No          | Pos unit | DINT      |
| 27C1h | 1-254  | Interpolation data record for 2 <sup>nd</sup> profile | RW     | No          | Pos unit | DINT      |
| 2741h | Interpolation data read/write pointer position monitor |   |        |             |          |           |
|       | 1  | Interpolation data read pointer position              | RO     | Yes         | –        | UINT      |
|       | 2  | Interpolation data write pointer position             | RO     | Yes         | –        | UINT      |
| 607Dh | Software position limit                                |   |        |             |          |           |
|       | 1  | Min position limit                                    | RW     | No          | Pos unit | DINT      |
|       | 2  | Max position limit                                    | RW     | No          | Pos unit | DINT      |
| 6084h | 0  | Profile deceleration                                  | RW     | Yes         | Acc unit | UDINT     |
| 6085h | 0  | Quick stop deceleration                               | RW     | Yes         | Acc unit | UDINT     |

◆ Object Setting Procedure

The recommended object setting procedure to use mode 2 is given in the following table.

| Step | Description  |
|------|--|
| 1    | Set <i>interpolation submode select</i> (60C0h).   |
| 2    | Set <i>interpolation profile select</i> (2732h).   |
| 3    | Set <i>interpolation data configuration for 1st profile</i> (2730h) and <i>interpolation data configuration for 2nd profile</i> (2731h). |
| 4    | Set <i>interpolation data record for 1st profile</i> (27C0h) and <i>interpolation data record for 2nd profile</i> (27C1h).               |
| 5    | Set <i>mode of operation</i> (6060h).  |
| 6    | Set <i>enable interpolation</i> (6060h bit 4).   |

### 13.3.3 Cyclic Synchronous Position Mode

The Cyclic Synchronous Position Mode is used for the interpolated positioning in the same way as the Interpolated Position Mode. In this mode, speed and torque compensations can be specified by the master to enable speed and torque feedforward.

The *interpolation time period* defines the interval at which the target position is updated. Interpolation is performed in the SERVOPACK according to this setting. The target position is interpreted as an absolute value.

The following figure shows the block diagram for the Cyclic Synchronous Position Mode.

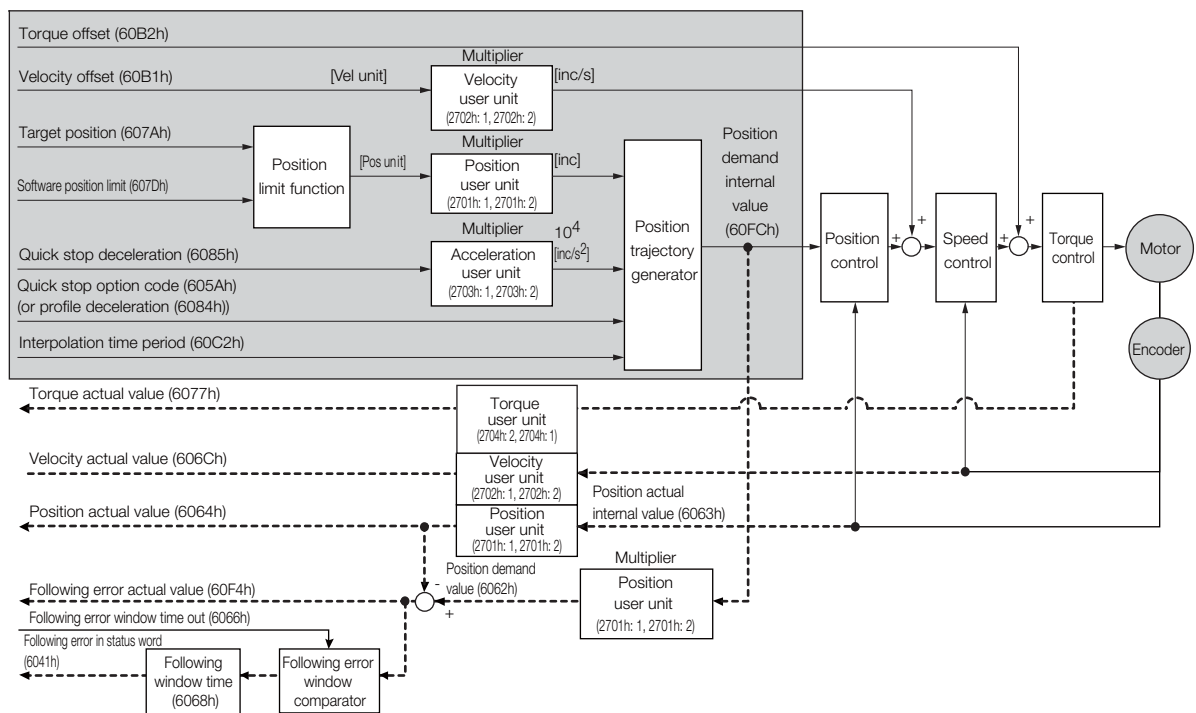

### ◆ Related Objects

| Index | Subindex                  | Name                            | Access | PDO Mapping | Unit     | Data Type |
|-------|---------------------------|---------------------------------|--------|-------------|----------|-----------|
| 607Ah | 0                         | Target position                 | RW     | Yes         | Pos unit | DINT      |
| 607Dh | Software position limit   |                                 |        |             |          |           |
|       | 1                         | Min position limit              | RW     | No          | Pos unit | DINT      |
|       | 2                         | Max position limit              | RW     | No          | Pos unit | DINT      |
| 6084h | 0                         | Profile deceleration            | RW     | Yes         | Acc unit | UDINT     |
| 6085h | 0                         | Quick stop deceleration         | RW     | Yes         | Acc unit | UDINT     |
| 60B1h | 0                         | Velocity offset                 | RW     | Yes         | Vel unit | DINT      |
| 60B2h | 0                         | Torque offset                   | RW     | Yes         | Trq unit | INT       |
| 60C2h | Interpolation time period |                                 |        |             |          |           |
|       | 1                         | Interpolation time period value | RO     | No          | –        | USINT     |
|       | 2                         | Interpolation time index        | RO     | No          | –        | SINT      |

# 13.4 Homing

The following figure shows the relationship between the input objects and the output objects in the Homing Mode. You can specify the speeds, acceleration rate, and homing method. You can also use *home offset* to offset zero in the user coordinate system from the home position.

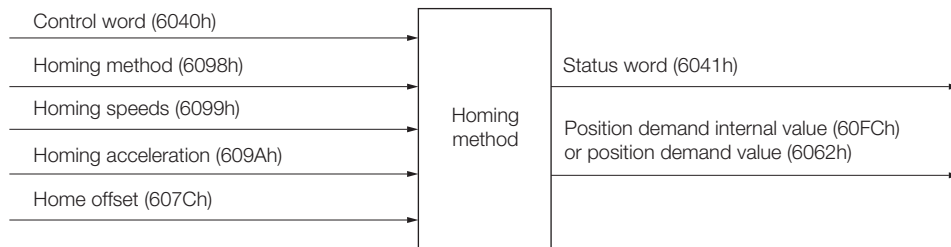

## 13.4.1 Related Objects

| Index | Subindex | Name                           | Access | PDO Mapping | Unit     | Data Type |
|-------|----------|--------------------------------|--------|-------------|----------|-----------|
| 6040h | 0        | Control word                   | RW     | Yes         | –        | UINT      |
| 6041h | 0        | Status word                    | RO     | Yes         | –        | UINT      |
| 607Ch | 0        | Home offset                    | RW     | No          | Pos unit | DINT      |
| 6098h | 0        | Homing method                  | RW     | Yes         | –        | SINT      |
|       |          | Homing speeds                  |        |             |          |           |
| 6099h | 1        | Speed during search for switch | RW     | Yes         | Vel unit | UDINT     |
|       | 2        | Speed during search for zero   | RW     | Yes         | Vel unit | UDINT     |
| 609Ah | 0        | Homing acceleration            | RW     | Yes         | Acc unit | UDINT     |

## 13.4.2 Homing Method

| Value | Definition  | Description  |
|-------|---|--|
| 0     | –   | No homing  |
| 1     | Homing with the negative limit switch and index pulse | <p>With this method, homing starts in the negative direction if the negative limit switch is inactive. The home position is the first index pulse that is detected after the negative limit switch becomes inactive.</p> <p>Index pulse<br/>Negative limit switch (N-OT)</p> |

Continued on next page.

Continued from previous page.

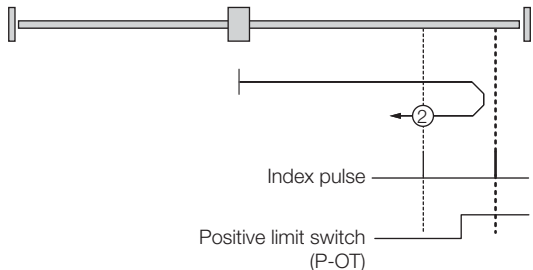
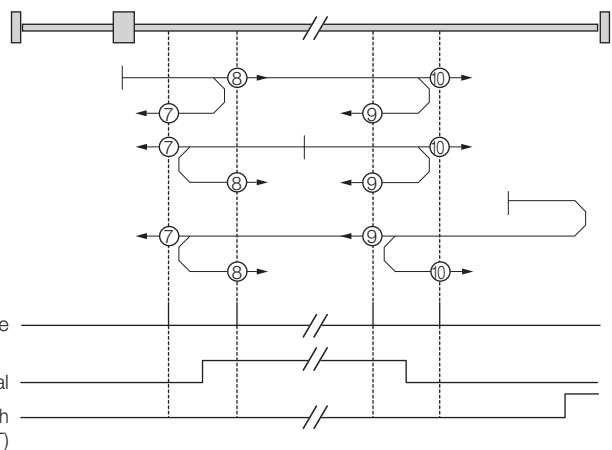
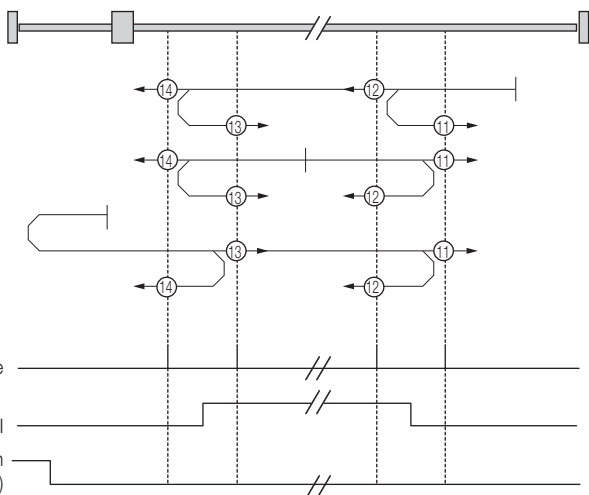
| Value    | Definition  | Description   |
|----------|---|---|
| 2        | Homing with the positive limit switch and index pulse   | <p>With this method, homing starts in the positive direction if the positive limit switch is inactive. The home position is the first index pulse that is detected after the positive limit switch becomes inactive.</p>  <p>Index pulse</p> <p>Positive limit switch (P-OT)</p>  |
| 7 to 10  | Homing with the home switch input (/Home) signal and index pulse and starting in the positive direction | <p>With methods 7 to 10, homing starts in the positive direction. However, if the /Home signal is already active when homing is started, the initial homing direction depends on the required edge. The home position will be the index pulse on either the rising or falling edge side of the /Home signal. If the initial movement direction is away from the /Home signal, the motor will reverse direction when the limit switch in the movement direction is input.</p>  <p>Index pulse</p> <p>/Home signal</p> <p>Positive limit switch (P-OT)</p> |
| 11 to 14 | Homing with the home switch input (/Home) signal and index pulse and starting in the negative direction | <p>These methods are similar to methods 7 to 10 except that homing starts in the negative direction.</p>  <p>Index pulse</p> <p>/Home signal</p> <p>Negative limit switch (N-OT)</p>  |

Continued on next page.

Continued from previous page.

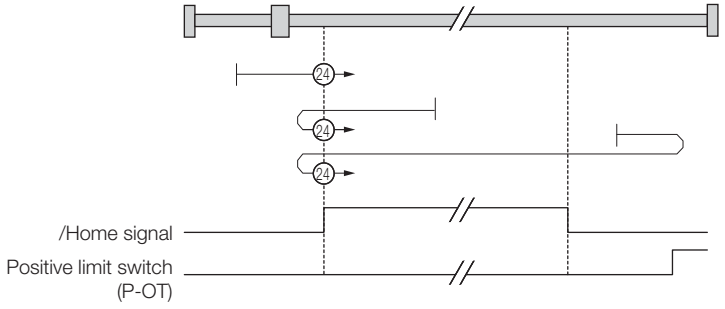
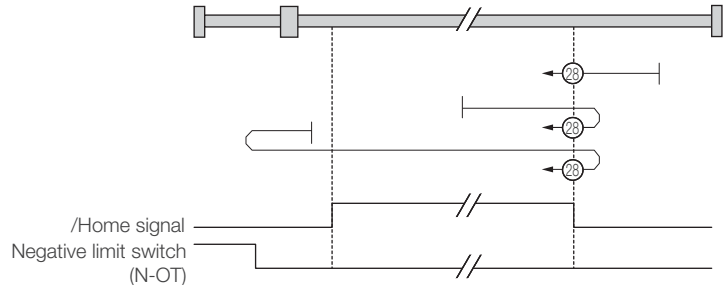
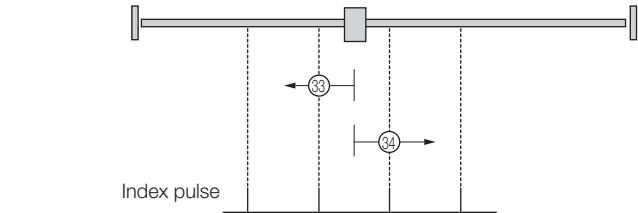
| Value  | Definition  | Description   |
|--------|---|---|
| 24     | Homing with the home switch input (/Home) signal and starting in the positive direction | <p>This method is same as method 8 except that the home position does not depend on the index pulse. Here, it depends only on changes in the relevant /Home signal or limit switch.</p>  <p>/Home signal<br/>Positive limit switch (P-OT)</p>   |
| 28     | Homing with the home switch input (/Home) signal and starting in the negative direction | <p>This method is same as method 12 except that the home position does not depend on the index pulse. Here, it depends only on changes in the relevant /Home signal or limit switch.</p>  <p>/Home signal<br/>Negative limit switch (N-OT)</p> |
| 33, 34 | Homing with the index pulse   |  <p>Index pulse</p>   |
| 35     | Homing with the current position  | <p>With this method, the current position is defined as the home position. You can execute this method even if the Servo Drive is not in the Operation Enabled state (default setting).</p>   |

Note: The index pulse is the encoder's zero signal (phase C).

## 13.5 Velocity Control Modes

### 13.5.1 Profile Velocity Mode

In the Profile Velocity Mode, the speed is output according to the *profile acceleration* and *profile deceleration* until it reaches the *target velocity*.

The following figure shows the block diagram for the Profile Velocity Mode.

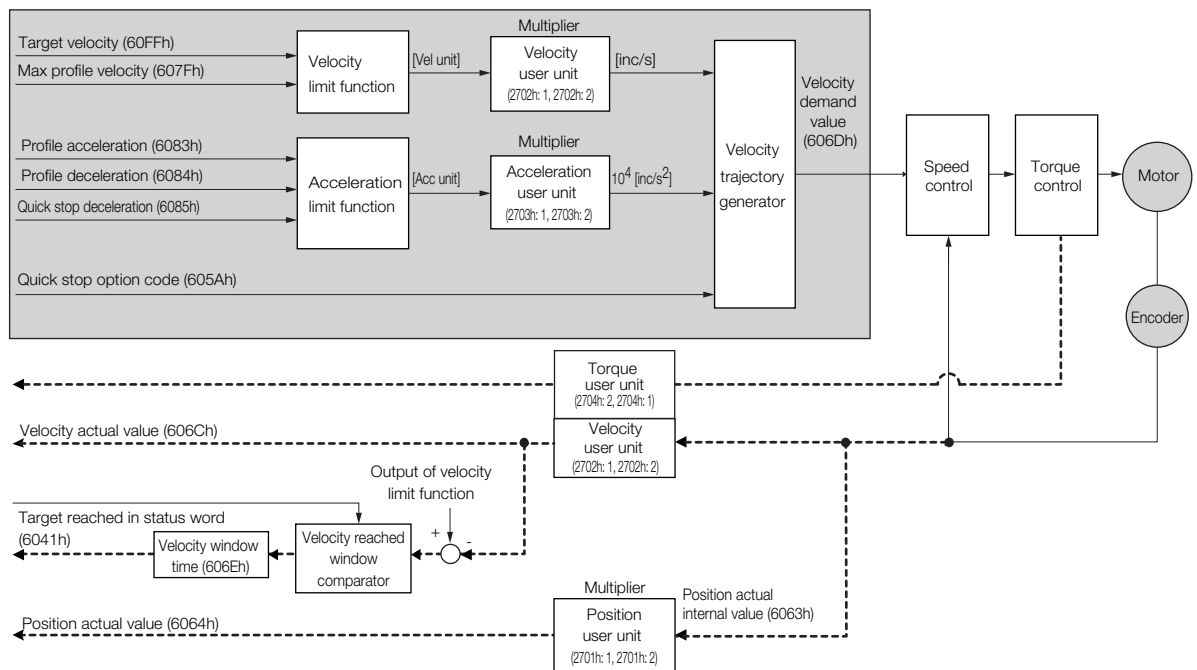

### Related Objects

| Index | Subindex | Name                    | Access | PDO Mapping | Unit     | Data Type |
|-------|----------|-------------------------|--------|-------------|----------|-----------|
| 60FFh | 0        | Target velocity         | RW     | Yes         | Vel unit | DINT      |
| 607Fh | 0        | Max profile velocity    | RW     | Yes         | Vel unit | UDINT     |
| 6083h | 0        | Profile acceleration    | RW     | Yes         | Acc unit | UDINT     |
| 6084h | 0        | Profile deceleration    | RW     | Yes         | Acc unit | UDINT     |
| 6085h | 0        | Quick stop deceleration | RW     | Yes         | Acc unit | UDINT     |
| 606Bh | 0        | Velocity demand value   | RO     | Yes         | Vel unit | DINT      |
| 606Ch | 0        | Velocity actual value   | RO     | Yes         | Vel unit | DINT      |
| 606Dh | 0        | Velocity window         | RW     | No          | Vel unit | UINT      |
| 606Eh | 0        | Velocity window time    | RW     | No          | ms       | UINT      |

## 13.5.2 Cyclic Synchronous Velocity Mode

In the Cyclic Synchronous Velocity Mode, the master provides the target speed to the Servo Drive, which performs speed control. In this mode, a torque compensation can be specified by the master to enable torque feedforward.

The following figure shows the block diagram for the Cyclic Synchronous Velocity Mode.

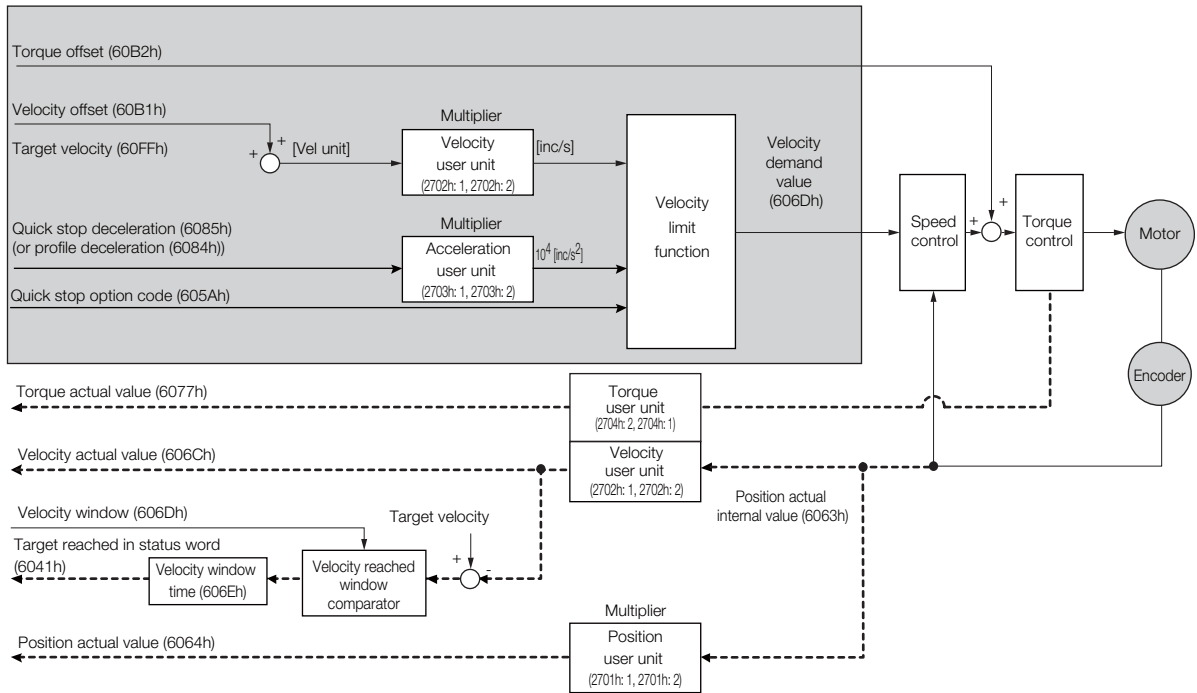

### Related Objects

| Index | Subindex | Name                    | Access | PDO Mapping | Unit     | Data Type |
|-------|----------|-------------------------|--------|-------------|----------|-----------|
| 60FFh | 0        | Target velocity         | RW     | Yes         | Vel unit | DINT      |
| 60B1h | 0        | Velocity offset         | RW     | Yes         | Vel unit | DINT      |
| 60B2h | 0        | Torque offset           | RW     | Yes         | 0.1%*    | INT       |
| 6084h | 0        | Profile deceleration    | RW     | Yes         | Acc unit | UDINT     |
| 6085h | 0        | Quick stop deceleration | RW     | Yes         | Acc unit | UDINT     |
| 606Bh | 0        | Velocity demand value   | RO     | Yes         | Vel unit | DINT      |
| 606Ch | 0        | Velocity actual value   | RO     | Yes         | Vel unit | DINT      |
| 606Dh | 0        | Velocity window         | RW     | No          | Vel unit | UINT      |
| 606Eh | 0        | Velocity window time    | RW     | No          | ms       | UINT      |

\* The rated motor torque is 100%.



## 13.6 Torque Control Modes

### 13.6.1 Profile Torque Mode

In the Profile Torque Mode, the torque is output up to the *target torque* according to the *torque slope* setting.

The following figure shows the block diagram for the Profile Torque Mode.

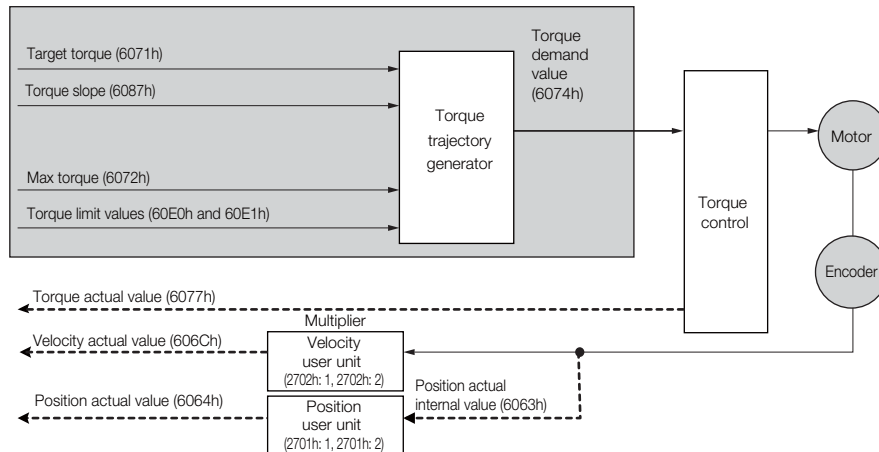

### Related Objects

| Index | Subindex | Name                        | Access | PDO Mapping | Unit    | Data Type |
|-------|----------|-----------------------------|--------|-------------|---------|-----------|
| 6071h | 0        | Target torque               | RW     | Yes         | 0.1%*   | INT       |
| 6087h | 0        | Torque slope                | RW     | Yes         | 0.1%/s* | UDINT     |
| 6074h | 0        | Torque demand value         | RO     | Yes         | 0.1%*   | INT       |
| 6077h | 0        | Torque actual value         | RO     | Yes         | 0.1%*   | INT       |
| 6072h | 0        | Max torque                  | RW     | Yes         | 0.1%*   | UINT      |
| 60E0h | 0        | Positive torque limit value | RW     | Yes         | 0.1%*   | UINT      |
| 60E1h | 0        | Negative torque limit value | RW     | Yes         | 0.1%*   | UINT      |

\* The rated motor torque is 100%.

## 13.6.2 Cyclic Sync Torque Mode

In the Cyclic Synchronous Torque Mode, the master provides the *target torque* to the Servo Drive, which performs torque control.

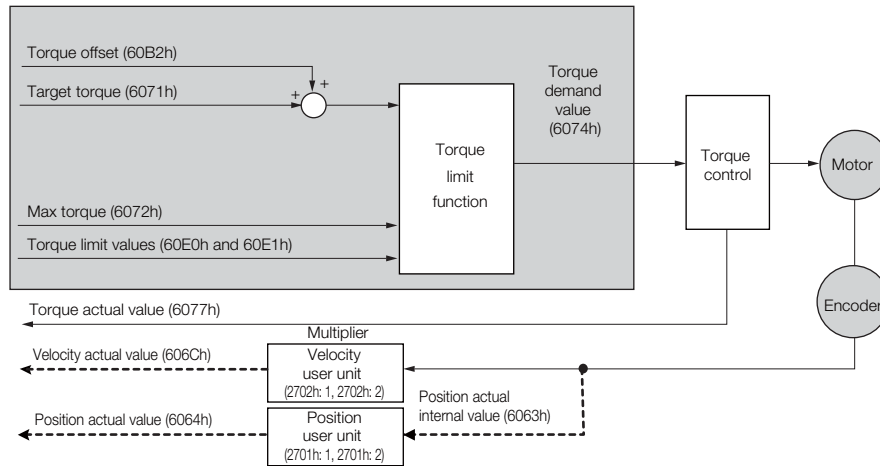

### Related Objects

| Index | Subindex | Name                        | Access | PDO Mapping | Unit  | Data Type |
|-------|----------|-----------------------------|--------|-------------|-------|-----------|
| 6071h | 0        | Target torque               | RW     | Yes         | 0.1%* | INT       |
| 6074h | 0        | Torque demand value         | RO     | Yes         | 0.1%* | INT       |
| 6077h | 0        | Torque actual value         | RO     | Yes         | 0.1%* | INT       |
| 60B2h | 0        | Torque offset               | RW     | Yes         | 0.1%* | INT       |
| 6072h | 0        | Max torque                  | RW     | Yes         | 0.1%* | UINT      |
| 60E0h | 0        | Positive torque limit value | RW     | Yes         | 0.1%* | UINT      |
| 60E1h | 0        | Negative torque limit value | RW     | Yes         | 0.1%* | UINT      |

\* The rated motor torque is 100%.

## 13.7 Torque Limits

The following figure shows the block diagram for the torque limits. The torque is limited by the lowest limit value.

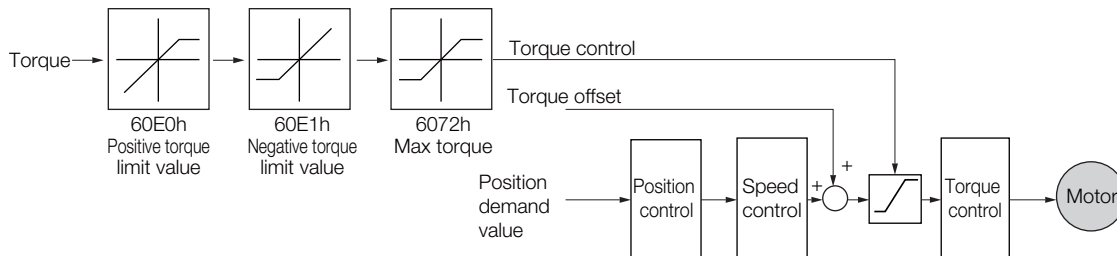

### Related Objects

| Index | Subindex | Name                        | Access | PDO Mapping | Unit  | Data Type |
|-------|----------|-----------------------------|--------|-------------|-------|-----------|
| 6072h | 0        | Max torque                  | RW     | Yes         | 0.1%* | UINT      |
| 60E0h | 0        | Positive torque limit value | RW     | Yes         | 0.1%* | UINT      |
| 60E1h | 0        | Negative torque limit value | RW     | Yes         | 0.1%* | UINT      |

\* The rated motor torque is 100%.

## 13.8 Digital I/O Signals

The *digital inputs* and *digital outputs* are used to control the I/O signals of the CN1 connector on the SERVOPACK.

| Index | Subindex        | Name             | Access | PDO Mapping | Unit | Data Type |
|-------|-----------------|------------------|--------|-------------|------|-----------|
| 60FDh | 0               | Digital inputs   | RO     | Yes         | –    | UDINT     |
| 60FEh | Digital outputs |                  |        |             |      |           |
|       | 1               | Physical outputs | RW     | Yes         | –    | UDINT     |
|       | 2               | Bit mask         | RW     | No          | –    | UDINT     |

## 13.9 Touch Probe

You can latch the feedback position with the following trigger events.

- Trigger with probe 1 input (Probe 1 Latch Input (/Probe1) signal)
- Trigger with probe 2 input (Probe 2 Latch Input (/Probe2) signal)
- Trigger with encoder zero signal (phase C)

The following two touch probe latches can be used at the same time.

### ■ Touch Probe 1 Latch

- Latch control object: 60B8h (bits 0 to 7)
- Latch status object: 60B9h (bits 0 to 7)
- The latched position is always stored in *touch probe 1 position value* (60BAh).
- Trigger signal: Encoder zero signal or /Probe1 signal

### ■ Touch Probe 2 Latch

- Latch control object: 60B8h (bits 8 to 15)
- Latch status object: 60B9h (bits 8 to 15)
- The latched position is always stored in *touch probe 2 position value* (60BCh).
- Trigger signal: /Probe2 signal

You can change the connector pin assignments and the /Probe1 and /Probe2 signal logic in the Probe 1 Latch Input Signal parameter (Pn511 = X ) and the Probe 2 Latch Input Signal parameter (Pn511 = X ).

Note: Touch probe 1 cannot be used during homing. If touch probe 1 was already active, it will be switched OFF.

## 13.9.1 Related Objects

| Index | Subindex | Name                         | Access | PDO Mapping | Unit     | Data Type |
|-------|----------|------------------------------|--------|-------------|----------|-----------|
| 60B8h | 0        | Touch probe function         | RW     | Yes         | –        | UINT      |
| 60B9h | 0        | Touch probe status           | RO     | Yes         | –        | UINT      |
| 60BAh | 0        | Touch probe 1 position value | RO     | Yes         | Pos unit | DINT      |
| 60BCh | 0        | Touch probe 2 position value | RO     | Yes         | Pos unit | DINT      |

## 13.9.2 Example of Execution Procedure for a Touch Probe

- Single Trigger Mode (60B8h bit 1 = 0 or bit 9 = 0)

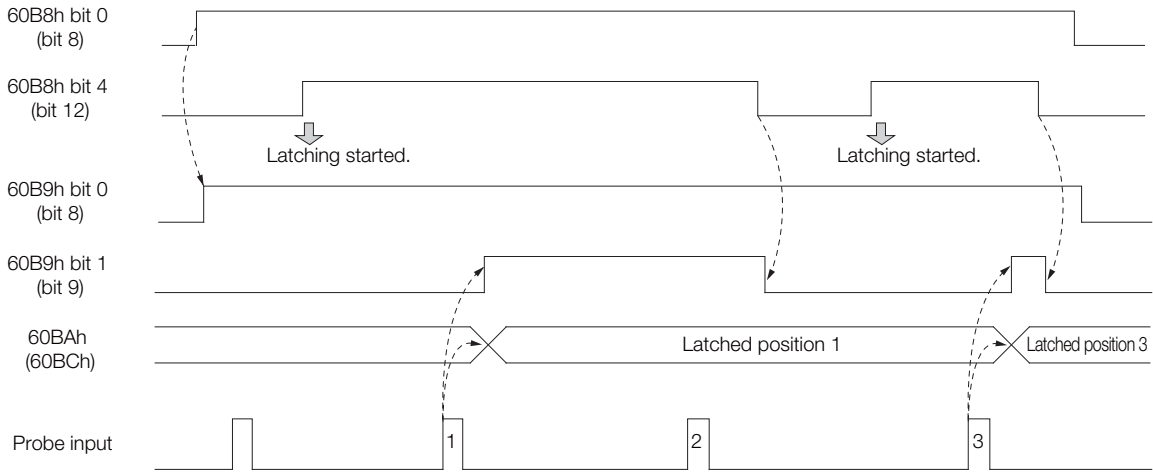

- Continuous Trigger Mode (60B8h bit 1 = 1 or bit 9 = 1)

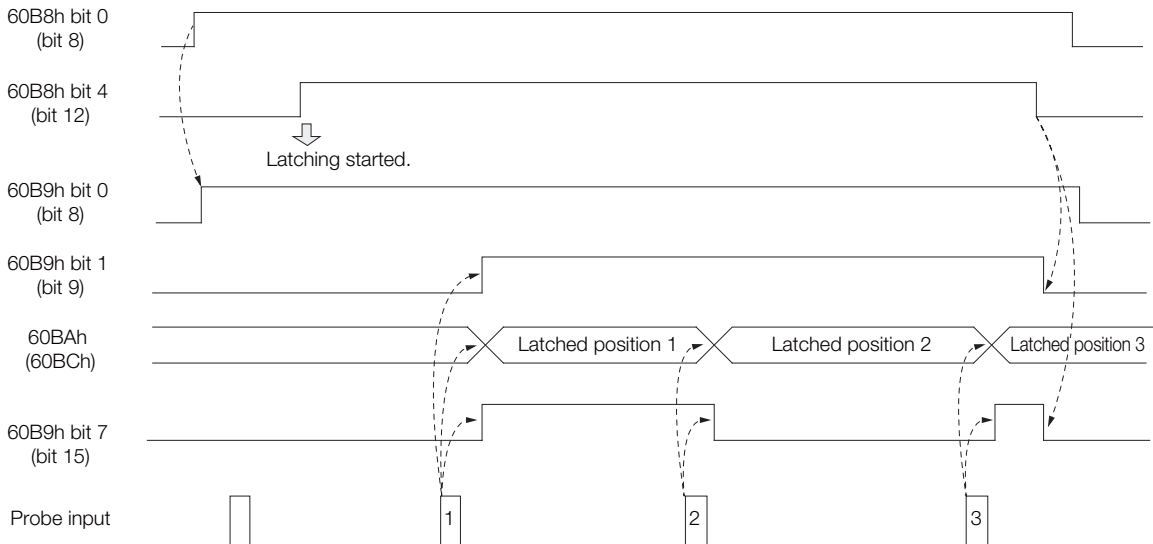

# Object Dictionary

---

# 14

This chapter provides tables of the objects that are supported by an EtherCAT SERVOPACK. Each object is described.

|              |  |              |
|--------------|--|--------------|
| <b>14.1</b>  | <b>Object Dictionary List</b>                            | <b>14-3</b>  |
| <b>14.2</b>  | <b>Interpreting Object Descriptions</b>                  | <b>14-5</b>  |
| <b>14.3</b>  | <b>General Objects</b>                                   | <b>14-6</b>  |
| <b>14.4</b>  | <b>PDO Mapping Objects</b>                               | <b>14-10</b> |
| <b>14.5</b>  | <b>Sync Manager Communications Objects</b>               | <b>14-18</b> |
| <b>14.6</b>  | <b>Manufacturer-Specific Objects</b>                     | <b>14-22</b> |
| <b>14.7</b>  | <b>Device Control</b>                                    | <b>14-28</b> |
| <b>14.8</b>  | <b>Profile Position Mode</b>                             | <b>14-36</b> |
| <b>14.9</b>  | <b>Homing Mode</b>                                       | <b>14-38</b> |
| <b>14.10</b> | <b>Position Control Function</b>                         | <b>14-40</b> |
| <b>14.11</b> | <b>Interpolated Position Mode</b>                        | <b>14-42</b> |
| <b>14.12</b> | <b>Cyclic Synchronous Position Mode</b>                  | <b>14-48</b> |
| <b>14.13</b> | <b>Profile Velocity/Cyclic Synchronous Velocity Mode</b> | <b>14-49</b> |

|              |  |              |
|--------------|--|--------------|
| <b>14.14</b> | <b>Profile Torque/Cyclic Synchronous Torque Mode . .</b> | <b>14-50</b> |
| <b>14.15</b> | <b>Torque Limit Function . . . . .</b>                   | <b>14-51</b> |
| <b>14.16</b> | <b>Touch Probe Function . . . . .</b>                    | <b>14-52</b> |
| <b>14.17</b> | <b>Digital Inputs/Outputs . . . . .</b>                  | <b>14-54</b> |



# 14.1 Object Dictionary List

The following table lists the dictionary objects.

| Functional Classification          | Object Name                        | Index                               | Refer to |
|------------------------------------|------------------------------------|-------------------------------------|----------|
| General Objects                    | Device type                        | (1000h)                             | 14.3     |
|                                    | Error register                     | (1001h)                             | 14.3     |
|                                    | Manufacturer device name           | (1008h)                             | 14.3     |
|                                    | Manufacturer software version      | (100Ah)                             | 14.3     |
|                                    | Store parameters                   | (1010h)                             | 14.3     |
|                                    | Restore default parameters         | (1011h)                             | 14.3     |
|                                    | Identity object                    | (1018h)                             | 14.3     |
| PDO Mapping Objects                | Receive PDO mapping                | (1600h to 1603h and 1610h to 1613h) | 14.4     |
|                                    | Transmit PDO mapping               | (1A00h to 1A03h and 1A10h to 1A13h) | 14.4     |
| Sync Manager Communication Objects | Sync manager communication type    | (1C00h)                             | 14.5     |
|                                    | Sync manager PDO assignment        | (1C10h and 1C13h)                   | 14.5     |
|                                    | Sync manager synchronization       | (1C32h and 1C33h)                   | 14.5     |
|                                    | Sync error setting                 | (10F1h)                             | 14.5     |
| Manufacturer Specific Objects      | SERVOPACK parameters               | (2000h to 26FFh)                    | 14.6     |
|                                    | User parameter configuration       | (2700h)                             | 14.6     |
|                                    | Position user unit                 | (2701h)                             | 14.6     |
|                                    | Velocity user unit                 | (2702h)                             | 14.6     |
|                                    | Acceleration user unit             | (2703h)                             | 14.6     |
|                                    | Torque User Unit                   | (2704h)                             | 14.6     |
|                                    | Encoder Selection                  | (2705h)                             | 14.5     |
| Device Control                     | SERVOPACK adjusting command object | (2710h)                             | 14.6     |
|                                    | Error code                         | (603Fh)                             | 14.7     |
|                                    | Control word                       | (6040h)                             | 14.7     |
|                                    | Status word                        | (6041h)                             | 14.7     |
|                                    | Quick stop option code             | (605Ah)                             | 14.7     |
|                                    | Shutdown option code               | (605Bh)                             | 14.7     |
|                                    | Disable operation option code      | (605Ch)                             | 14.7     |
|                                    | Halt option code                   | (605Dh)                             | 14.7     |
|                                    | Fault reaction option code         | (605Eh)                             | 14.7     |
|                                    | Modes of operation                 | (6060h)                             | 14.7     |
|                                    | Modes of operation display         | (6061h)                             | 14.7     |
|                                    | Supported drive modes              | (6502h)                             | 14.7     |
| Profile Position Mode              | Target position                    | (607Ah)                             | 14.8     |
|                                    | Software position limit            | (607Dh)                             | 14.8     |
|                                    | Max profile velocity               | (607Fh)                             | 14.8     |
|                                    | Profile velocity                   | (6081h)                             | 14.8     |
|                                    | Profile acceleration               | (6083h)                             | 14.8     |
|                                    | Profile deceleration               | (6084h)                             | 14.8     |
|                                    | Quick stop deceleration            | (6085h)                             | 14.8     |

Continued on next page.

Continued from previous page.

| Functional Classification                         | Object Name   | Index   | Refer to |
|---|---|---------|----------|
| Homing Mode                                       | Home offset   | (607Ch) | 14.9     |
|   | Homing method   | (6098h) | 14.9     |
|   | Homing speeds   | (6099h) | 14.9     |
|   | Homing acceleration   | (609Ah) | 14.9     |
| Position Control Function                         | Position demand value   | (6062h) | 14.10    |
|   | Position actual internal value                                | (6063h) | 14.10    |
|   | Position actual value   | (6064h) | 14.10    |
|   | Position demand internal value                                | (60FCh) | 14.10    |
|   | Following error window  | (6065h) | 14.10    |
|   | Following error time out                                      | (6066h) | 14.10    |
|   | Following error actual value                                  | (60F4h) | 14.10    |
|   | Position window   | (6067h) | 14.10    |
| Position window time                              | (6068h)   | 14.10   |          |
| Interpolated Position Mode                        | Interpolation sub mode select                                 | (60C0h) | 14.11    |
|   | Interpolation data record                                     | (60C1h) | 14.11    |
|   | Interpolation time period                                     | (60C2h) | 14.11    |
|   | Manufacturer interpolation data configuration for 1st profile | (2730h) | 14.11    |
|   | Manufacturer interpolation data configuration for 2nd profile | (2731h) | 14.11    |
|   | Interpolation profile select                                  | (2732h) | 14.11    |
|   | Interpolation data record for 1st profile                     | (27C0h) | 14.11    |
|   | Interpolation data record for 2nd profile                     | (27C1h) | 14.11    |
|   | Interpolation data read/write pointer position                | (2741h) | 14.11    |
| Cyclic Synchronous Position Mode                  | Velocity offset   | (60B1h) | 14.12    |
|   | Torque offset   | (60B2h) | 14.12    |
| Profile Velocity/Cyclic Synchronous Velocity Mode | Velocity demand value   | (606Bh) | 14.13    |
|   | Velocity actual value   | (606Ch) | 14.13    |
|   | Velocity window   | (606Dh) | 14.13    |
|   | Velocity window time  | (606Eh) | 14.13    |
|   | Target velocity   | (60FFh) | 14.13    |
| Profile Torque/Cyclic Synchronous Velocity Mode   | Target torque   | (6071h) | 14.14    |
|   | Torque demand value   | (6074h) | 14.14    |
|   | Torque slope  | (6087h) | 14.14    |
|   | Motor rated torque  | (6076h) | 14.14    |
|   | Torque actual value   | (6077h) | 14.14    |
| Torque Limit Function                             | Max torque  | (6072h) | 14.15    |
|   | Positive torque limit value                                   | (60E0h) | 14.15    |
|   | Negative torque limit value                                   | (60E1h) | 14.15    |
| Touch Probe Function                              | Touch probe function  | (60B8h) | 14.16    |
|   | Touch probe status  | (60B9h) | 14.16    |
|   | Touch probe 1 position value                                  | (60BAh) | 14.16    |
|   | Touch probe 2 position value                                  | (60BCh) | 14.16    |
| Digital Inputs/Outputs                            | Digital inputs  | (60FDh) | 14.17    |
|   | Digital outputs   | (60FEh) | 14.17    |

## 14.2 Interpreting Object Descriptions

The  $\Sigma$ -7W SERVOPACK requires object settings for two axes.

The settings of some objects must be configured per axis, and the settings of other objects are common to both axes.

This section describes the following information listed for these objects.

Information about the axis is shown using symbols.

**Axis A** : Object valid for axis A only.

**Axis B** : Object valid for axis B only.

**Common** : Object common to axes A and B.

### Device Type (1000h) **Axis A**

This object contains the device type and functionality.

| Index | Subindex | Name        | Data Type | Access | PDO Mapping | Value      | Saving to EEPROM |
|-------|----------|-------------|-----------|--------|-------------|------------|------------------|
| 1000h | 0        | Device type | UDINT     | RO     | No          | 0x00020192 | No               |

When the index numbers of axes A and B are different, those numbers are shown in parentheses.

### User Parameter Configuration (A: 2700h, B: 2F00h)

This object enables all user parameter settings and initializes all of the position data.

| Index | Subindex | Name                         | Data Type | Access | PDO Mapping | Value                        | Saving to EEPROM |
|-------|----------|------------------------------|-----------|--------|-------------|------------------------------|------------------|
| 2700h | 0        | User parameter configuration | UDINT     | RW     | No          | 0 to 0xFFFFFFFF (default: 0) | No               |

## 14.3 General Objects

### Device Type (1000h) Common

This object contains the device type and functionality.

| Index | Subindex | Name        | Data Type | Access | PDO Mapping | Value      | Saving to EEPROM |
|-------|----------|-------------|-----------|--------|-------------|------------|------------------|
| 1000h | 0        | Device type | UDINT     | RO     | No          | 0x00020192 | No               |

#### ◆ Data Description

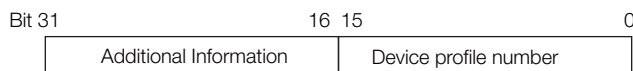

Additional information: 0002 (Servo Drive)

Device profile number: 0192 (DS402)

### Error Register (1001h) Common

This object contains the error status of the device. The value of this object is stored as part of an emergency message.

| Index | Subindex | Name           | Data Type | Access | PDO Mapping | Value | Saving to EEPROM |
|-------|----------|----------------|-----------|--------|-------------|-------|------------------|
| 1001h | 0        | Error register | USINT     | RO     | No          | 0x00  | No               |

#### ◆ Data Description

| Bit    | Data          | Description           |
|--------|---------------|-----------------------|
| 0      | Generic error | 0: No error, 1: Error |
| 1 to 7 | Reserved.     | 0: Always 0           |

### Manufacturer Device Name (1008h) Common

This object contains the SERVOPACK model name.

| Index | Subindex | Name                     | Data Type | Access | PDO Mapping | Value | Saving to EEPROM |
|-------|----------|--------------------------|-----------|--------|-------------|-------|------------------|
| 1008h | 0        | Manufacturer device name | STRING    | RO     | No          | –     | No               |

### Manufacturer Software Version (100Ah) Common

This object contains the software version of the SERVOPACK.

| Index | Subindex | Name                          | Data Type | Access | PDO Mapping | Value | Saving to EEPROM |
|-------|----------|-------------------------------|-----------|--------|-------------|-------|------------------|
| 100Ah | 0        | Manufacturer software version | STRING    | RO     | No          | –     | No               |

#### ◆ Data Description

The following string is saved.

“xxx.\*\*\* (D:oooo)”

xxx.\*\*\*: Software version of EtherCAT (CoE)

oooo: Software version of the SERVOPACK

## Store Parameters Field (1010h) Common

You can use this object to save the parameter settings in non-volatile memory.

| Index | Subindex | Name                                 | Data Type | Access | PDO Mapping | Value  | Saving to EEPROM |
|-------|----------|--------------------------------------|-----------|--------|-------------|--|------------------|
| 1010h | 0        | Largest subindex supported           | USINT     | RO     | No          | 4  | No               |
|       | 1        | Save all parameters                  | UDINT     | RW     | No          | 0x00000000 to 0xFFFFFFFF (default: 0x00000001) | No               |
|       | 2        | Save communication parameters        | UDINT     | RW     | No          | 0x00000000 to 0xFFFFFFFF (default: 0x00000001) | No               |
|       | 3        | Save application parameters          | UDINT     | RW     | No          | 0x00000000 to 0xFFFFFFFF (default: 0x00000001) | No               |
|       | 4        | Save manufacturer defined parameters | UDINT     | RW     | No          | 0x00000000 to 0xFFFFFFFF (default: 0x00000001) | No               |

If you read the object entry data, a value will be returned that tells whether the SERVOPACK can save the parameters.

| Bit | Value | Meaning   |
|-----|-------|---|
| 1   | 0     | The SERVOPACK does not save the parameters autonomously.  |
| 0   | 0     | The SERVOPACK does not save the parameters for a command. |
|     | 1     | The SERVOPACK saves the parameters for a command.         |

To prevent saving parameters by mistake, they are saved only when a specific signature is written to the appropriate subindex. The signature is “save.”

| Signature | MSB |     |     |     | LSB |  |  |  |
|-----------|-----|-----|-----|-----|-----|--|--|--|
| ASCII     | e   | v   | a   | s   |     |  |  |  |
| hex       | 65h | 76h | 61h | 73h |     |  |  |  |

If you write “save” to subindex 1, all parameters are saved.

If you write “save” to subindex 2, the communications parameters (objects 1000h to 1FFFh) are saved.

If you write “save” to subindex 3, the application parameters (objects 27□□h and 6□□□h) are saved.

If you write “save” to subindex 4, the SERVOPACK parameters (objects 2000h to 26FFh) are saved.

Note: 1. If an incorrect signature is written, the SERVOPACK refuses to save the parameters and returns an SDO abort code.

2. If you read the object entry data while parameters are being saved, 0 will be returned.

3. Subindex 1 and subindex 4 can be written only in the Switch ON Disabled state (servo OFF).

4. After storing parameters with subindex 1 or subindex 4, you must turn the power supply OFF and ON again to move to the Operation Enabled state.

## Restore Default Parameters (1011h) Common

You can use this object to restore the parameters to the default values.

| Index | Subindex | Name  | Data Type | Access | PDO Mapping | Value  | Saving to EEPROM |
|-------|----------|---|-----------|--------|-------------|--|------------------|
| 1011h | 0        | Largest subindex supported                      | USINT     | RO     | No          | 4  | No               |
|       | 1        | Restore all default parameters                  | UDINT     | RW     | No          | 0x00000000 to 0xFFFFFFFF (default: 0x00000001) | No               |
|       | 2        | Restore communication default parameters        | UDINT     | RW     | No          | 0x00000000 to 0xFFFFFFFF (default: 0x00000001) | No               |
|       | 3        | Restore application default parameters          | UDINT     | RW     | No          | 0x00000000 to 0xFFFFFFFF (default: 0x00000001) | No               |
|       | 4        | Restore manufacturer defined default parameters | UDINT     | RW     | No          | 0x00000000 to 0xFFFFFFFF (default: 0x00000001) | No               |

If you read the object entry data, a value will be returned that tells whether the SERVOPACK can initialize the parameters.

| Bit | Value | Description  |
|-----|-------|--|
| 0   | 0     | The SERVOPACK does not restore the parameters to the default values. |
|     | 1     | The SERVOPACK restores the parameters to the default values.         |

To prevent restoring the parameters to the default values by mistake, the parameters are restored to the default values only when a specific signature is written to the appropriate subindex. The signature is “load.”

|           |  |     |     |     |
|-----------|--|-----|-----|-----|
| Signature | MSB <span style="float: right;">LSB</span> |     |     |     |
| ASCII     | d  | a   | o   | l   |
| hex       | 64h  | 61h | 6Fh | 6Ch |

If you write “load” to subindex 1, all parameters are restored to the default values.

If you write “load” to subindex 2, the communications parameters (objects 1□□□h) are restored to the default values.

If you write “load” to subindex 3, the application parameters (objects 27□□h and 6□□□h) are restored to the default values.

If you write “load” to subindex 4, the SERVOPACK parameters (objects 2000h to 26FFh) are restored to the default values.

- Note:
1. If an incorrect signature is written, the SERVOPACK refuses to restore the default values and returns an SDO abort code.
  2. Subindex 1 and subindex 4 can be written only in the Switch ON Disabled state (servo OFF).
  3. If you read this object while the default values are being restored, 0 will be returned.
  4. The default values are enabled after the SERVOPACK is reset or after the power supply to the SERVOPACK is turned OFF and ON again.

## Identity Object (1018h) Common

This object contains general information on the device.

| Index | Subindex | Name                          | Data Type | Access | PDO Mapping | Value                    | Saving to EEPROM |
|-------|----------|-------------------------------|-----------|--------|-------------|--------------------------|------------------|
| 1018h | 0        | Number of entries             | USINT     | RO     | No          | 4                        | No               |
|       | 1        | Vendor ID                     | UDINT     | RO     | No          | 0x00000539               | No               |
|       | 2        | Product code                  | UDINT     | RO     | No          | 0x02200402 <sup>*1</sup> | No               |
|       | 3        | Revision number <sup>*2</sup> | UDINT     | RO     | No          | –                        | No               |
|       | 4        | Serial number <sup>*3</sup>   | UDINT     | RO     | No          | 0x00000000               | No               |

\*1. For SGD7W-□□□DA0□: 0x02200402

\*2. The revision number is saved as follows:

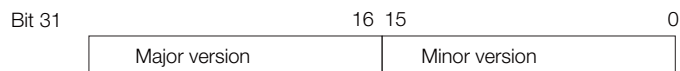

The major version identifies the operating specifications of EtherCAT (CoE). If the CoE functionality is expanded, the major version has to be increased. The minor version number identifies different versions with the same operating specifications.

\*3. Serial Number is not used. (It is always 0.)

# 14.4 PDO Mapping Objects

The CANopen over EtherCAT protocol allows the user to map objects to process data objects (PDOs) in order to use the PDOs for realtime data transfer.

The PDO mappings define which objects will be included in the PDOs.

A mapping entry (subindexes 1 to 8) is defined as shown below.

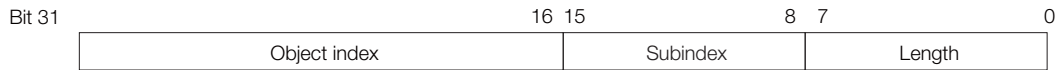

Bits 0 to 7: The length of the mapped object in bits. (If there is a gap in the PDOs, the bit length of the gap is given.)

Bits 8 to 15: The subindex of the mapped object (0 if there is a gap in the PDOs).

Bits 16 to 31: The index of the mapped object (0 if there is a gap in the PDOs).

**Information** The objects mapped to PDOs can be changed only when the EtherCAT (CoE) Network Module is in the Pre-Operational state.  
Set the mapping entries (subindexes 1 to 8) only after you write 0 to subindex 0.

## Receive PDO Mapping (1600h to 1603h) Axis A

### ◆ 1st Receive PDO Mapping

| Index | Sub-index | Name                          | Data Type | Access | PDO Mapping | Value                                    | Saving to EEPROM |
|-------|-----------|-------------------------------|-----------|--------|-------------|--|------------------|
| 1600h | 0         | Number of objects in this PDO | USINT     | RW     | No          | 0 to 8<br>(default: 8)                   | Yes              |
|       | 1         | Mapping entry 1               | UDINT     | RW     | No          | 0 to 0xFFFFFFFF<br>(default: 0x60400010) | Yes              |
|       | 2         | Mapping entry 2               | UDINT     | RW     | No          | 0 to 0xFFFFFFFF<br>(default: 0x607A0020) | Yes              |
|       | 3         | Mapping entry 3               | UDINT     | RW     | No          | 0 to 0xFFFFFFFF<br>(default: 0x60FF0020) | Yes              |
|       | 4         | Mapping entry 4               | UDINT     | RW     | No          | 0 to 0xFFFFFFFF<br>(default: 0x60710010) | Yes              |
|       | 5         | Mapping entry 5               | UDINT     | RW     | No          | 0 to 0xFFFFFFFF<br>(default: 0x60720010) | Yes              |
|       | 6         | Mapping entry 6               | UDINT     | RW     | No          | 0 to 0xFFFFFFFF<br>(default: 0x60600008) | Yes              |
|       | 7         | Mapping entry 7               | UDINT     | RW     | No          | 0 to 0xFFFFFFFF<br>(default: 0x00000008) | Yes              |
|       | 8         | Mapping entry 8               | UDINT     | RW     | No          | 0 to 0xFFFFFFFF<br>(default: 0x60B80010) | Yes              |



### ◆ 2nd Receive PDO Mapping

| Index | Subindex | Name                                  | Data Type | Access | PDO Mapping | Value  | Saving to EEPROM |
|-------|----------|---------------------------------------|-----------|--------|-------------|--|------------------|
| 1601h | 0        | Number of objects in this PDO         | USINT     | RW     | No          | 0 to 8<br>(default: 2)                         | Yes              |
|       | 1        | Mapping entry 1                       | UDINT     | RW     | No          | 0 to<br>0xFFFFFFFF<br>(default:<br>0x60400010) | Yes              |
|       | 2        | Mapping entry 2                       | UDINT     | RW     | No          | 0 to<br>0xFFFFFFFF<br>(default:<br>0x607A0020) | Yes              |
|       | 3 to 8   | Mapping entry 3 to<br>Mapping entry 8 | UDINT     | RW     | No          | 0 to<br>0xFFFFFFFF<br>(default: 0)             | Yes              |

### ◆ 3rd Receive PDO Mapping

| Index | Subindex | Name                                  | Data Type | Access | PDO Mapping | Value  | Saving to EEPROM |
|-------|----------|---------------------------------------|-----------|--------|-------------|--|------------------|
| 1602h | 0        | Number of objects in this PDO         | USINT     | RW     | No          | 0 to 8<br>(default: 2)                         | Yes              |
|       | 1        | Mapping entry 1                       | UDINT     | RW     | No          | 0 to<br>0xFFFFFFFF<br>(default:<br>0x60400010) | Yes              |
|       | 2        | Mapping entry 2                       | UDINT     | RW     | No          | 0 to<br>0xFFFFFFFF<br>(default:<br>0x60FF0020) | Yes              |
|       | 3 to 8   | Mapping entry 3 to<br>Mapping entry 8 | UDINT     | RW     | No          | 0 to<br>0xFFFFFFFF<br>(default: 0)             | Yes              |

### ◆ 4th Receive PDO Mapping

| Index | Subindex | Name                                  | Data Type | Access | PDO Mapping | Value  | Saving to EEPROM |
|-------|----------|---------------------------------------|-----------|--------|-------------|--|------------------|
| 1603h | 0        | Number of objects in this PDO         | USINT     | RW     | No          | 0 to 8<br>(default: 2)                         | Yes              |
|       | 1        | Mapping entry 1                       | UDINT     | RW     | No          | 0 to<br>0xFFFFFFFF<br>(default:<br>0x60400010) | Yes              |
|       | 2        | Mapping entry 2                       | UDINT     | RW     | No          | 0 to<br>0xFFFFFFFF<br>(default:<br>0x60710010) | Yes              |
|       | 3 to 8   | Mapping entry 3 to<br>Mapping entry 8 | UDINT     | RW     | No          | 0 to<br>0xFFFFFFFF<br>(default: 0)             | Yes              |

## Receive PDO Mapping (1610h to 1613h) Axis B

### ◆ 1st Receive PDO Mapping

| Index | Subindex | Name                          | Data Type | Access | PDO Mapping | Value                                 | Saving to EEPROM |
|-------|----------|-------------------------------|-----------|--------|-------------|---------------------------------------|------------------|
| 1610h | 0        | Number of objects in this PDO | USINT     | RW     | No          | 0 to 8 (default: 8)                   | Yes              |
|       | 1        | Mapping entry 1               | UDINT     | RW     | No          | 0 to 0xFFFFFFFF (default: 0x68400010) | Yes              |
|       | 2        | Mapping entry 2               | UDINT     | RW     | No          | 0 to 0xFFFFFFFF (default: 0x687A0020) | Yes              |
|       | 3        | Mapping entry 3               | UDINT     | RW     | No          | 0 to 0xFFFFFFFF (default: 0x68FF0020) | Yes              |
|       | 4        | Mapping entry 4               | UDINT     | RW     | No          | 0 to 0xFFFFFFFF (default: 0x68710010) | Yes              |
|       | 5        | Mapping entry 5               | UDINT     | RW     | No          | 0 to 0xFFFFFFFF (default: 0x68720010) | Yes              |
|       | 6        | Mapping entry 6               | UDINT     | RW     | No          | 0 to 0xFFFFFFFF (default: 0x68600008) | Yes              |
|       | 7        | Mapping entry 7               | UDINT     | RW     | No          | 0 to 0xFFFFFFFF (default: 0x00000008) | Yes              |
|       | 8        | Mapping entry 8               | UDINT     | RW     | No          | 0 to 0xFFFFFFFF (default: 0x68B80010) | Yes              |

### ◆ 2nd Receive PDO Mapping

| Index | Subindex | Name                               | Data Type | Access | PDO Mapping | Value                                 | Saving to EEPROM |
|-------|----------|------------------------------------|-----------|--------|-------------|---------------------------------------|------------------|
| 1611h | 0        | Number of objects in this PDO      | USINT     | RW     | No          | 0 to 8 (default: 2)                   | Yes              |
|       | 1        | Mapping entry 1                    | UDINT     | RW     | No          | 0 to 0xFFFFFFFF (default: 0x68400010) | Yes              |
|       | 2        | Mapping entry 2                    | UDINT     | RW     | No          | 0 to 0xFFFFFFFF (default: 0x687A0020) | Yes              |
|       | 3 to 8   | Mapping entry 3 to Mapping entry 8 | UDINT     | RW     | No          | 0 to 0xFFFFFFFF (default: 0)          | Yes              |

## ◆ 3rd Receive PDO Mapping

| Index | Subindex | Name                               | Data Type | Access | PDO Mapping | Value                                 | Saving to EEPROM |
|-------|----------|------------------------------------|-----------|--------|-------------|---------------------------------------|------------------|
| 1612h | 0        | Number of objects in this PDO      | USINT     | RW     | No          | 0 to 8 (default: 2)                   | Yes              |
|       | 1        | Mapping entry 1                    | UDINT     | RW     | No          | 0 to 0xFFFFFFFF (default: 0x68400010) | Yes              |
|       | 2        | Mapping entry 2                    | UDINT     | RW     | No          | 0 to 0xFFFFFFFF (default: 0x68FF0020) | Yes              |
|       | 3 to 8   | Mapping entry 3 to Mapping entry 8 | UDINT     | RW     | No          | 0 to 0xFFFFFFFF (default: 0)          | Yes              |

## ◆ 4th Receive PDO Mapping

| Index | Subindex | Name                               | Data Type | Access | PDO Mapping | Value                                 | Saving to EEPROM |
|-------|----------|------------------------------------|-----------|--------|-------------|---------------------------------------|------------------|
| 1613h | 0        | Number of objects in this PDO      | USINT     | RW     | No          | 0 to 8 (default: 2)                   | Yes              |
|       | 1        | Mapping entry 1                    | UDINT     | RW     | No          | 0 to 0xFFFFFFFF (default: 0x68400010) | Yes              |
|       | 2        | Mapping entry 2                    | UDINT     | RW     | No          | 0 to 0xFFFFFFFF (default: 0x68710010) | Yes              |
|       | 3 to 8   | Mapping entry 3 to Mapping entry 8 | UDINT     | RW     | No          | 0 to 0xFFFFFFFF (default: 0)          | Yes              |

## Transmit PDO Mapping (1A00h to 1A03h) Axis A

### ◆ 1st Transmit PDO Mapping

| Index | Sub-index | Name                          | Data Type | Access | PDO Mapping | Value                                    | Saving to EEPROM |
|-------|-----------|-------------------------------|-----------|--------|-------------|--|------------------|
| 1A00h | 0         | Number of objects in this PDO | USINT     | RW     | No          | 0 to 8<br>(default: 8)                   | Yes              |
|       | 1         | Mapping entry 1               | UDINT     | RW     | No          | 0 to 0xFFFFFFFF<br>(default: 0x60410010) | Yes              |
|       | 2         | Mapping entry 2               | UDINT     | RW     | No          | 0 to 0xFFFFFFFF<br>(default: 0x60640020) | Yes              |
|       | 3         | Mapping entry 3               | UDINT     | RW     | No          | 0 to 0xFFFFFFFF<br>(default: 0x60770010) | Yes              |
|       | 4         | Mapping entry 4               | UDINT     | RW     | No          | 0 to 0xFFFFFFFF<br>(default: 0x60F40020) | Yes              |
|       | 5         | Mapping entry 5               | UDINT     | RW     | No          | 0 to 0xFFFFFFFF<br>(default: 0x60610008) | Yes              |
|       | 6         | Mapping entry 6               | UDINT     | RW     | No          | 0 to 0xFFFFFFFF<br>(default: 0x00000008) | Yes              |
|       | 7         | Mapping entry 7               | UDINT     | RW     | No          | 0 to 0xFFFFFFFF<br>(default: 0x60B90010) | Yes              |
|       | 8         | Mapping entry 8               | UDINT     | RW     | No          | 0 to 0xFFFFFFFF<br>(default: 0x60BA0020) | Yes              |

### ◆ 2nd Transmit PDO Mapping

| Index | Sub-index | Name                               | Data Type | Access | PDO Mapping | Value                                    | Saving to EEPROM |
|-------|-----------|------------------------------------|-----------|--------|-------------|--|------------------|
| 1A01h | 0         | Number of objects in this PDO      | USINT     | RW     | No          | 0 to 8<br>(default: 2)                   | Yes              |
|       | 1         | Mapping entry 1                    | UDINT     | RW     | No          | 0 to 0xFFFFFFFF<br>(default: 0x60410010) | Yes              |
|       | 2         | Mapping entry 2                    | UDINT     | RW     | No          | 0 to 0xFFFFFFFF<br>(default: 0x60640020) | Yes              |
|       | 3 to 8    | Mapping entry 3 to Mapping entry 8 | UDINT     | RW     | No          | 0 to 0xFFFFFFFF<br>(default: 0)          | Yes              |

### ◆ 3rd Transmit PDO Mapping

| Index | Subindex | Name                                  | Data Type | Access | PDO Mapping | Value  | Saving to EEPROM |
|-------|----------|---------------------------------------|-----------|--------|-------------|--|------------------|
| 1A02h | 0        | Number of objects in this PDO         | USINT     | RW     | No          | 0 to 8<br>(default: 2)                         | Yes              |
|       | 1        | Mapping entry 1                       | UDINT     | RW     | No          | 0 to<br>0xFFFFFFFF<br>(default:<br>0x60410010) | Yes              |
|       | 2        | Mapping entry 2                       | UDINT     | RW     | No          | 0 to<br>0xFFFFFFFF<br>(default:<br>0x60640020) | Yes              |
|       | 3 to 8   | Mapping entry 3 to<br>Mapping entry 8 | UDINT     | RW     | No          | 0 to<br>0xFFFFFFFF<br>(default: 0)             | Yes              |

### ◆ 4th Transmit PDO Mapping

| Index | Subindex | Name                                  | Data Type | Access | PDO Mapping | Value  | Saving to EEPROM |
|-------|----------|---------------------------------------|-----------|--------|-------------|--|------------------|
| 1A03h | 0        | Number of objects in this PDO         | USINT     | RW     | No          | 0 to 8<br>(default: 3)                         | Yes              |
|       | 1        | Mapping entry 1                       | UDINT     | RW     | No          | 0 to<br>0xFFFFFFFF<br>(default:<br>0x60410010) | Yes              |
|       | 2        | Mapping entry 2                       | UDINT     | RW     | No          | 0 to<br>0xFFFFFFFF<br>(default:<br>0x60640020) | Yes              |
|       | 3        | Mapping entry 3                       | UDINT     | RW     | No          | 0 to<br>0xFFFFFFFF<br>(default:<br>0x60770010) | Yes              |
|       | 4 to 8   | Mapping entry 4 to<br>Mapping entry 8 | UDINT     | RW     | No          | 0 to<br>0xFFFFFFFF<br>(default: 0)             | Yes              |

## Transmit PDO Mapping (1A10h to 1A13h) Axis B

### ◆ 1st Transmit PDO Mapping

| Index | Sub-index | Name                          | Data Type | Access | PDO Mapping | Value                                 | Saving to EEPROM |
|-------|-----------|-------------------------------|-----------|--------|-------------|---------------------------------------|------------------|
| 1A10h | 0         | Number of objects in this PDO | USINT     | RW     | No          | 0 to 8 (default: 8)                   | Yes              |
|       | 1         | Mapping entry 1               | UDINT     | RW     | No          | 0 to 0xFFFFFFFF (default: 0x68410010) | Yes              |
|       | 2         | Mapping entry 2               | UDINT     | RW     | No          | 0 to 0xFFFFFFFF (default: 0x68640020) | Yes              |
|       | 3         | Mapping entry 3               | UDINT     | RW     | No          | 0 to 0xFFFFFFFF (default: 0x68770010) | Yes              |
|       | 4         | Mapping entry 4               | UDINT     | RW     | No          | 0 to 0xFFFFFFFF (default: 0x68F40020) | Yes              |
|       | 5         | Mapping entry 5               | UDINT     | RW     | No          | 0 to 0xFFFFFFFF (default: 0x68610008) | Yes              |
|       | 6         | Mapping entry 6               | UDINT     | RW     | No          | 0 to 0xFFFFFFFF (default: 0x00000008) | Yes              |
|       | 7         | Mapping entry 7               | UDINT     | RW     | No          | 0 to 0xFFFFFFFF (default: 0x68B90010) | Yes              |
|       | 8         | Mapping entry 8               | UDINT     | RW     | No          | 0 to 0xFFFFFFFF (default: 0x68BA0020) | Yes              |

### ◆ 2nd Transmit PDO Mapping

| Index | Sub-index | Name                               | Data Type | Access | PDO Mapping | Value                                 | Saving to EEPROM |
|-------|-----------|------------------------------------|-----------|--------|-------------|---------------------------------------|------------------|
| 1A11h | 0         | Number of objects in this PDO      | USINT     | RW     | No          | 0 to 8 (default: 2)                   | Yes              |
|       | 1         | Mapping entry 1                    | UDINT     | RW     | No          | 0 to 0xFFFFFFFF (default: 0x68410010) | Yes              |
|       | 2         | Mapping entry 2                    | UDINT     | RW     | No          | 0 to 0xFFFFFFFF (default: 0x68640020) | Yes              |
|       | 3 to 8    | Mapping entry 3 to Mapping entry 8 | UDINT     | RW     | No          | 0 to 0xFFFFFFFF (default: 0)          | Yes              |

## ◆ 3rd Transmit PDO Mapping

| Index | Subindex | Name                               | Data Type | Access | PDO Mapping | Value                                 | Saving to EEPROM |
|-------|----------|------------------------------------|-----------|--------|-------------|---------------------------------------|------------------|
| 1A12h | 0        | Number of objects in this PDO      | USINT     | RW     | No          | 0 to 8 (default: 2)                   | Yes              |
|       | 1        | Mapping entry 1                    | UDINT     | RW     | No          | 0 to 0xFFFFFFFF (default: 0x68410010) | Yes              |
|       | 2        | Mapping entry 2                    | UDINT     | RW     | No          | 0 to 0xFFFFFFFF (default: 0x68640020) | Yes              |
|       | 3 to 8   | Mapping entry 3 to Mapping entry 8 | UDINT     | RW     | No          | 0 to 0xFFFFFFFF (default: 0)          | Yes              |

## ◆ 4th Transmit PDO Mapping

| Index | Subindex | Name                               | Data Type | Access | PDO Mapping | Value                                 | Saving to EEPROM |
|-------|----------|------------------------------------|-----------|--------|-------------|---------------------------------------|------------------|
| 1A13h | 0        | Number of objects in this PDO      | USINT     | RW     | No          | 0 to 8 (default: 3)                   | Yes              |
|       | 1        | Mapping entry 1                    | UDINT     | RW     | No          | 0 to 0xFFFFFFFF (default: 0x68410010) | Yes              |
|       | 2        | Mapping entry 2                    | UDINT     | RW     | No          | 0 to 0xFFFFFFFF (default: 0x68640020) | Yes              |
|       | 3        | Mapping entry 3                    | UDINT     | RW     | No          | 0 to 0xFFFFFFFF (default: 0x68770010) | Yes              |
|       | 4 to 8   | Mapping entry 4 to Mapping entry 8 | UDINT     | RW     | No          | 0 to 0xFFFFFFFF (default: 0)          | Yes              |

## 14.5 Sync Manager Communications Objects

### Sync Manager Communications Type (1C00h) Common

| Index | Sub-index | Name                                 | Data Type | Access | PDO Mapping | Value                                    | Saving to EEPROM |
|-------|-----------|--------------------------------------|-----------|--------|-------------|--|------------------|
| 1C00h | 0         | Number of used Sync Manager channels | USINT     | RO     | No          | 4  | No               |
|       | 1         | Communication type sync manager 0    | USINT     | RO     | No          | 1: Mailbox reception (master to slave)   | No               |
|       | 2         | Communication type sync manager 1    | USINT     | RO     | No          | 2: Mailbox send (slave to master)        | No               |
|       | 3         | Communication type sync manager 2    | USINT     | RO     | No          | 3: Process data output (master to slave) | No               |
|       | 4         | Communication type sync manager 3    | USINT     | RO     | No          | 4: Process data input (slave to master)  | No               |

### Sync Manager PDO Assignment (1C10h to 1C13h) Common

This object defines which PDOs will be transferred in the process data communications.

| Index | Sub-index | Name                          | Data Type | Access | PDO Mapping | Value                           | Saving to EEPROM |
|-------|-----------|-------------------------------|-----------|--------|-------------|---------------------------------|------------------|
| 1C10h | 0         | Sync manager PDO assignment 0 | USINT     | RO     | No          | 0                               | No               |
| 1C11h | 0         | Sync manager PDO assignment 1 | USINT     | RO     | No          | 0                               | No               |
| 1C12h | 0         | Number of assigned PDOs       | USINT     | RW     | No          | 0 to 4 (default: 2)             | Yes              |
|       | 1         | Index of assigned RxPDO 1     | UINT      | RW     | No          | 1A00h to 1A13h (default: 1A01h) | Yes              |
|       | 2         | Index of assigned RxPDO 2     | UINT      | RW     | No          | 1A00h to 1A13h (default: 1A11h) | Yes              |
|       | 3         | Index of assigned RxPDO 3     | UINT      | RW     | No          | 1A00h to 1A13h (default: 1A00h) | Yes              |
|       | 4         | Index of assigned RxPDO 4     | UINT      | RW     | No          | 1A00h to 1A13h (default: 1A10h) | Yes              |
| 1C13h | 0         | Number of assigned PDOs       | USINT     | RW     | No          | 0 to 4 (default: 2)             | Yes              |
|       | 1         | Index of assigned TxPDO 1     | UINT      | RW     | No          | 1600h to 1613h (default: 1601h) | Yes              |
|       | 2         | Index of assigned TxPDO 2     | UINT      | RW     | No          | 1600h to 1613h (default: 1611h) | Yes              |
|       | 3         | Index of assigned TxPDO 3     | UINT      | RW     | No          | 1600h to 1613h (default: 1600h) | Yes              |
|       | 4         | Index of assigned TxPDO 4     | UINT      | RW     | No          | 1600h to 1613h (default: 1610h) | Yes              |

Objects 1C12h and 1C13h can be changed when the EtherCAT (CoE) Network Module is in the Pre-Operational state. Set subindex 1 or 2 only after you write 0 to subindex 0.



## Sync Manager Synchronization (1C32h and 1C33h) Common

### ◆ Sync Manager 2 (Process Data Output) Synchronization

| Index | Subindex | Name                                 | Data Type | Access | PDO Mapping | Value  | Saving to EEPROM |
|-------|----------|--------------------------------------|-----------|--------|-------------|--|------------------|
| 1C32h | 0        | Number of synchronization parameters | USINT     | RO     | No          | 12   | No               |
|       | 1        | Synchronization type                 | UINT      | RO     | No          | 0: Free-Run (DC not used)<br>2: DC Sync0 (DC used)   | No               |
|       | 2        | Cycle time                           | UDINT     | RO     | No          | Sync0 event cycle [ns]   | No               |
|       | 3        | Shift time                           | UDINT     | RO     | No          | 250,000 [ns]   | No               |
|       | 4        | Synchronization types supported      | UINT      | RO     | No          | Bit 0 = 1: Free-Run supported<br><br>Bits 2 to 4 = 001: DC Sync0 supported<br><br>Bits 5 and 6 = 00: Output shift not supported. | No               |
|       | 5        | Minimum cycle time                   | UDINT     | RO     | No          | 250,000 [ns]   | No               |
|       | 6        | Calc and copy time                   | UDINT     | RO     | No          | 62,500 [ns]  | No               |
|       | 7        | Reserved                             | UDINT     | RO     | No          | –  | No               |
|       | 8        | Reserved                             | UINT      | RO     | No          | –  | No               |
|       | 9        | Delay time                           | UDINT     | RO     | No          | 0 [ns]   | No               |
|       | 10       | Sync0 cycle time                     | UDINT     | RO     | No          | Same as 1C32h: 02.   | No               |
|       | 11       | SM event missed counter              | UINT      | RO     | No          | –  | No               |
| 12    | Reserved | UINT                                 | RO        | No     | –           | No   |                  |

◆ Sync Manager 3 (Process Data Input) Synchronization

| Index | Sub-index | Name                                 | Data Type | Access | PDO Mapping | Value   | Saving to EEPROM |
|-------|-----------|--------------------------------------|-----------|--------|-------------|---|------------------|
| 1C33h | 0         | Number of synchronization parameters | USINT     | RO     | No          | 10  | No               |
|       | 1         | Synchronization type                 | UINT      | RO     | No          | Same as 1C32h: 01.  | No               |
|       | 2         | Cycle time                           | UDINT     | RO     | No          | Same as 1C32h: 02.  | No               |
|       | 3         | Shift time                           | UDINT     | RW     | No          | 125,000 × n [ns]<br>(n = 1, 2, 3...)<br>Range: 0 to Sync0 event period -125,000   | Yes              |
|       | 4         | Synchronization types supported      | UINT      | RO     | No          | Bit 0 = 1: Free-Run supported.<br><br>Bits 2 to 4 = 001: DC Sync0 supported<br><br>Bits 5 and 6 = 01: Input shift with local timer supported. | No               |
|       | 5         | Minimum cycle time                   | UDINT     | RO     | No          | Same as 1C32h: 05.  | No               |
|       | 6         | Calc and copy time                   | UDINT     | RO     | No          | 62,500 [ns]   | No               |
|       | 7         | Reserved                             | UDINT     | RO     | No          | –   | No               |
|       | 8         | Reserved                             | UINT      | RO     | No          | –   | No               |
|       | 9         | Delay time                           | UDINT     | RO     | No          | 0   | No               |
|       | 10        | Sync0 cycle time                     | UDINT     | RO     | No          | Same as 1C32h: 10.  | No               |
|       | 11        | SM event missed counter              | UINT      | RO     | No          | –   | No               |
|       | 12        | Reserved                             | UINT      | RO     | No          | –   | No               |

## Sync Error Settings (10F1h) Common

| Index | Sub-index | Name                   | Data Type | Access | PDO Mapping | Value                | Saving to EEPROM |
|-------|-----------|------------------------|-----------|--------|-------------|----------------------|------------------|
| 10F1h | 0         | Number of entries      | USINT     | RO     | No          | 2                    | No               |
|       | 1         | Reserved               | UDINT     | RO     | No          | 0                    | No               |
|       | 2         | Sync error count limit | UINT      | RW     | No          | 0 to 15 (default: 9) | Yes              |

Note: Both 10F1h and 1F01h have the same function. You can set either object.

### ◆ 0x10F1h: 2 Sync Error Counter Limit

This object defines the allowable number of failures when receiving process data. If the value of the internal error counter in the SERVOPACK exceeds the value of this object, the SERVOPACK will detect an alarm (A12h) and change the ESM state to SAFEOP.

The SERVOPACK increments the internal error counter by 3 if the process output data is not updated (i.e., if a reception event does not occur) when the synchronization event (Sync0) occurs. When the process output data is updated normally, the internal error counter is decremented by 1. The internal error counter is reset when the EtherCAT communications state changes from SAFEOP to OP.

An example of internal error counter operation is shown below.

|  |   |   |   |   |   |   |   |           |   |   |   |
|--|---|---|---|---|---|---|---|-----------|---|---|---|
| Reception (SM2) event                                      | 1 | 0 | 1 | 0 | 1 | 0 | 1 | 0         | 1 | 0 | 1 |
| SERVOPACK internal error counter (Error Counter Limit = 9) | 0 | 3 | 2 | 5 | 4 | 7 | 6 | 9 (Error) | 9 | 9 | 9 |

In this example, a failure in receiving the process data occurs every other DC (Sync0) cycle. After eight DC cycles, the internal error count reaches the Sync Error Count Limit, and an error occurs.

No alarm will be detected if the DC mode is disabled or when the Sync Error Count Limit is set to 0.

If an A12h (EtherCAT Output Data Synchronization Error) alarm occurs, check 1C32h:11 (SM event missed counter) for an estimate of the frequency of reception failures. Use it as reference in setting the *sync error count limit*.

The number of reception failures for process data is given in 1C32h: 11. (This is not an internal error count. The counter is incremented each time there is a failure for one reception.)



Important

1. Set a suitable cycle time for updating the process data according to the requirements of the application.
2. Determine if the default setting of the Sync Error Counter Limit is suitable for the requirements of the application. With the default value of 9, network frames will be lost (SM2 reception events will not occur) three times consecutively before an alarm occurs in the SERVOPACK. If the setting of the Sync Error Counter Limit is too small, alarms will occur even when there is no problem in the application.
3. Noise may cause communications errors in the SERVOPACK. Check the SERVOPACK wiring and make sure that it has been performed to minimize the influence of noise. Implement noise countermeasures if necessary. Refer to the following section for information on noise countermeasures.

[4.1.2 Countermeasures against Noise on page 4-5](#)

## 14.6 Manufacturer-Specific Objects

### SERVOPACK Parameters (A: 2000h to 26FFh, B: 2800h to 2EFFh)

Objects 2000h to 26FFh are mapped to SERVOPACK parameters (Pn□□□□).

Object index 2□□□h corresponds to Pn□□□ in the SERVOPACK parameters (e.g., object 2100h is the same as Pn100).

### User Parameter Configuration (A: 2700h, B: 2F00h)

This object enables all user parameter settings and initializes all of the position data.

| Index | Sub-index | Name                         | Data Type | Access | PDO Mapping | Value                        | Saving to EEPROM |
|-------|-----------|------------------------------|-----------|--------|-------------|------------------------------|------------------|
| 2700h | 0         | User parameter configuration | UDINT     | RW     | No          | 0 to 0xFFFFFFFF (default: 0) | No               |

If you change any of the following objects and restart operation without turning the power supply OFF and then ON again, you must execute this object to enable the new settings.

- Objects 2701h, 2702h, 2703h, and 2704h
- SERVOPACK parameters that require that the power supply be turned OFF and ON again to enable changes to the parameter settings

#### ◆ Procedure

1. Change the SERVOPACK to the Switch ON Disabled state.
2. Set the new parameter settings.
3. Set *user parameter configuration* (2700h) to 1. The parameter settings will be enabled. After execution, object 2700h will automatically be reset to 0.

### Position User Unit (A: 2701h, B: 2F01h)

This object sets the user-defined position reference unit (Pos unit).

The user-defined position reference unit is calculated with the following formula.

$$1 \text{ [Pos unit]} = (\text{Numerator/Denominator}) \text{ [inc]}$$

| Index | Sub-index | Name              | Data Type | Access | PDO Mapping | Value                           | Saving to EEPROM |
|-------|-----------|-------------------|-----------|--------|-------------|---------------------------------|------------------|
| 2701h | 0         | Number of entries | USINT     | RO     | No          | 2                               | No               |
|       | 1         | Numerator         | UDINT     | RW     | No          | 1 to 1,073,741,823 (default: 1) | Yes              |
|       | 2         | Denominator       | UDINT     | RW     | No          | 1 to 1,073,741,823 (default: 1) | Yes              |

Setting range:  $1/4,096 < \text{Numerator/Denominator} < 65,536$

(Alarm A.A20 will be detected if the setting exceeds the setting range.)

## Velocity User Unit (A: 2702h, B: 2F02h)

This object sets the user-defined speed reference unit (Vel unit).

The user-defined speed reference unit is calculated with the following formula.

$$1 \text{ [Vel unit]} = (\text{Numerator/Denominator}) \text{ [inc/sec]}$$

| Index | Subindex | Name              | Data Type | Access | PDO Mapping | Value                           | Saving to EEPROM |
|-------|----------|-------------------|-----------|--------|-------------|---------------------------------|------------------|
| 2702h | 0        | Number of entries | USINT     | RO     | No          | 2                               | No               |
|       | 1        | Numerator         | UDINT     | RW     | No          | 1 to 1,073,741,823 (default: 1) | Yes              |
|       | 2        | Denominator       | UDINT     | RW     | No          | 1 to 1,073,741,823 (default: 1) | Yes              |

Setting range:  $1/128 \leq \text{Numerator/Denominator} \leq 8,388,608$

(Alarm A.A20 will be detected if the setting exceeds the setting range.)

## Acceleration User Unit (A: 2703h, B: 2F03h)

This object sets the user-defined acceleration reference unit (Acc unit).

The user-defined acceleration reference unit is calculated with the following formula.

$$1 \text{ [Acc unit]} = (\text{Numerator/Denominator}) \times 10^4 \text{ [inc/sec}^2\text{]}$$

| Index | Subindex | Name              | Data Type | Access | PDO Mapping | Value                           | Saving to EEPROM |
|-------|----------|-------------------|-----------|--------|-------------|---------------------------------|------------------|
| 2703h | 0        | Number of entries | USINT     | RO     | No          | 2                               | No               |
|       | 1        | Numerator         | UDINT     | RW     | No          | 1 to 1,073,741,823 (default: 1) | Yes              |
|       | 2        | Denominator       | UDINT     | RW     | No          | 1 to 1,073,741,823 (default: 1) | Yes              |

Setting range:  $1/128 \leq \text{Numerator/Denominator} \leq 262,144$

(Alarm A.A20 will be detected if the setting exceeds the setting range.)

## Torque User Unit (A: 2704h, B: 2F04h)

This object sets the user-defined torque reference unit (Torque unit).

| Index | Subindex | Name              | Data Type | Access | PDO Mapping | Value                           | Saving to EEPROM |
|-------|----------|-------------------|-----------|--------|-------------|---------------------------------|------------------|
| 2704h | 0        | Number of entries | USINT     | RO     | No          | 2                               | No               |
|       | 1        | Numerator         | UDINT     | RW     | No          | 1 to 1,073,741,823 (default: 1) | Yes              |
|       | 2        | Denominator       | UDINT     | RW     | No          | 1 to 1,073,741,823 (default: 1) | Yes              |

Setting range:  $1/256 \leq \text{Numerator/Denominator} \leq 1$

(Alarm A.A20 will be detected if the setting exceeds the setting range.)

## Encoder Selection (A: 2705h, B: 2F05h)

This object is used to select the encoder resolution.

| Index | Subindex | Name              | Data Type | Access | PDO Mappings | Value   | Saving to EEPROM |
|-------|----------|-------------------|-----------|--------|--------------|---|------------------|
| 2705h | 0        | Encoder Selection | UINT      | RW     | No           | 0000h (20 bits),<br>0001h (24 bits)<br>(default: 0000h) | Yes              |

## SERVOPACK Adjusting Command (A: 2710h, B: 2F10h)

This object is used for SERVOPACK adjustment services (e.g., encoder setup or multiturn reset). Write data to subindex 1 to start command execution. Also, read the subindex 3 to obtain the response. If you cannot obtain the response by reading subindex 3, the first byte of the response data will give information about the progress of execution.

| Index | Sub-index | Name              | Data Type | Access | PDO Mapping | Value  | Saving to EEPROM |
|-------|-----------|-------------------|-----------|--------|-------------|--|------------------|
| 2710h | 0         | Number of entries | USINT     | RO     | No          | 3  | No               |
|       | 1         | Command           | STRING    | RW     | No          | Bytes 0 to n: Service Request Data<br>The command is executed when command data is written.  | No               |
|       | 2         | Status            | USINT     | RO     | No          | 0: Command completed, no errors, and no response data<br>1: Command completed, no errors, and response data provided<br>2: Command completed, error, and no response data<br>3: Command completed, error, response data provided<br>255: Command is being executed | No               |
|       | 3         | Reply             | STRING    | RO     | No          | Byte 0: Subindex 2<br>Byte 1: Not used<br>2 to n: Service response data  | No               |

### ◆ Command/Response Data Format

| Command Data (Service Request Data) |  |
|-------------------------------------|--|
| Byte                                | Description  |
| 0                                   | Reserved.  |
| 1                                   | Reserved.  |
| 2                                   | CCMD (command code)<br>00: Read request<br>01: Write request |
| 3                                   | CSIZE (CDATA data byte size)                                 |
| 4 to 7                              | CADDRESS (address)   |
| 8 to 15                             | CDATA (writing data)   |

| Response Data (Service Response Data) |                                  |
|---------------------------------------|----------------------------------|
| Byte                                  | Description                      |
| 0                                     | Status (Same data as subindex 2) |
| 1                                     | Reserved.                        |
| 2                                     | RCMD (echoback of CCMD)          |
| 3                                     | RSIZE (R_DATA data byte size)    |
| 4 to 7                                | RADDRESS (echoback of CADDRESS)  |
| 8 to 15                               | RDATA (read data)/ERROCODE       |

### ◆ Executable Adjustment Services

| Adjustment Service                             | Request Code | Preparation before Execution | Processing Time | Execution Conditions  |
|--|--------------|------------------------------|-----------------|---|
| Absolute Encoder Reset                         | 1008h        | Required                     | 5 s max.        | Adjustment is disabled in the following cases. <ul style="list-style-type: none"> <li>• Test without a motor is enabled and no encoder is connected</li> <li>• An incremental encoder is used</li> <li>• Pn002 = n.□1□□ when an absolute encoder is used</li> <li>• While the servo is ON</li> </ul>                                    |
| Autotune Motor Current Detection Signal Offset | 100Eh        | Not required                 | 5 s max.        | Adjustment is disabled in the following cases. <ul style="list-style-type: none"> <li>• While the main circuit power supply is OFF</li> <li>• While the servo is ON</li> <li>• While the Servomotor is not stopped</li> </ul>   |
| Multiturn Limit Setting                        | 1013h        | Required                     | 5 s max.        | Adjustment is disabled in the following cases. <ul style="list-style-type: none"> <li>• Test without a motor is enabled and no encoder is connected</li> <li>• An incremental encoder is used</li> <li>• Pn002 = n.□1□□ when an absolute encoder is used</li> <li>• Multiturn Limit Disagreement Alarm (A.CC0) is not active</li> </ul> |
| Software Reset*                                | 2006h        | Not required                 | 5 s max.        | The software cannot be reset in the following cases. <ul style="list-style-type: none"> <li>• While the servo is ON</li> <li>• While the Servomotor is not stopped</li> </ul>   |

\* EtherCAT (CoE) communications will be disconnected after the software is reset. Repeat the operation sequence and establish communications again. Refer to the following sections for precautions required when resetting the software.

 **7.9 Software Reset**

### ◆ How to Send a Command for Adjustment

To execute the adjustment service, use the following procedure to send the adjustment command. Step 4 is not required when the software is reset.

**1. Send the following data and set the request code for the adjustment service to execute.**

CCMD = 0001h  
CSIZE = 02h  
CADDRESS = 00002000h  
CDATA = Request code of the adjustment service to execute\*

\* Select the request code from the table in ◆ *Executable Adjustment Services* on page 14-25.

If the slave station receives the command normally, the status field will be set to 1.  
If an error occurs, perform step 4 to stop execution.

**2. For an adjustment that requires preparations, send the following data.**

**If preparations before execution are not required, perform step 3.**

CCMD = 0001h  
CSIZE = 02h  
CADDRESS = 00002001h  
CDATA = 0002h

If the slave station receives the command normally, the status field will be set to 1.  
If an error occurs, perform step 4 to stop execution.

**3. Send the following data to execute the adjustment service.**

CCMD = 0001h  
CSIZE = 02h  
CADDRESS = 00002001h  
CDATA = 0001h

If the slave station receives the command normally, the status field will be set to 1.  
If an error occurs, perform step 4 to stop execution.

**4. Send the following data to stop execution.**

CCMD = 0001h  
CSIZE = 02h  
CADDRESS = 00002000h  
CDATA = 0000h

If the slave station receives the command normally, the status field will be set to 1.

Note: If no command is received within 10 seconds after step 1, the adjustment service will be automatically stopped.



## Safety Module Monitor (2720h)

This object shows the operating status of the Safety Module.

| Index | Subindex | Name                  | Data Type | Access | PDO Mapping | Value | Saving to EEPROM |
|-------|----------|-----------------------|-----------|--------|-------------|-------|------------------|
| 2720h | 0        | Safety module monitor | UDINT     | RO     | Yes         | –     | No               |

### ◆ Details

| Bit      | Signal                           | Description  |
|----------|----------------------------------|--|
| 0        | Safety Request Input Signal A1   | 0: Safety Request Input Signal A1 is ON. (Operation is normal.)  |
|          |                                  | 1: Safety Request Input Signal A1 is OFF. (Safety Function A is active.)   |
| 1        | Safety Request Input Signal A2   | 0: Safety Request Input Signal A2 is ON. (Operation is normal.)  |
|          |                                  | 1: Safety Request Input Signal A2 is OFF. (Safety Function A is active.)   |
| 2        | Safety Request Input Signal B1   | 0: Safety Request Input Signal B1 is ON. (Operation is normal.)  |
|          |                                  | 1: Safety Request Input Signal B1 is OFF. (Safety Function B is active.)   |
| 3        | Safety Request Input Signal B2   | 0: Safety Request Input Signal B2 is ON. (Operation is normal.)  |
|          |                                  | 1: Safety Request Input Signal B2 is OFF. (Safety Function B is active.)   |
| 4        | External Device Monitor Signal A | 0: External Device Monitor Output Signal A is OFF. (Operation is normal or a malfunction occurred in Safety Function A.) |
|          |                                  | 1: External Device Monitor Output Signal A is ON. (Safety Function A is active.)   |
| 5        | External Device Monitor Signal B | 0: External Device Monitor Output Signal B is OFF. (Operation is normal or a malfunction occurred in Safety Function B.) |
|          |                                  | 1: External Device Monitor Output Signal B is ON. (Safety Function B is active.)   |
| 6 and 7  | Reserved.                        | –  |
| 8        | Safety Function Monitoring       | 0: –   |
|          |                                  | 1: Monitoring is in progress.  |
| 9        | Safety Function Safe             | 0: –   |
|          |                                  | 1: Safe state  |
| 10       | Safety Function HWBB             | 0: –   |
|          |                                  | 1: HWBB function is operating.   |
| 12 to 15 | Reserved.                        | –  |
| 16       | Active Mode State                | 0: Standby or not selected.  |
|          |                                  | 1: Operating   |
| 17 to 31 | Reserved.                        | –  |

# 14.7 Device Control

## Error Code (A: 603Fh, B: 683Fh)

This object provides the SERVOPACK alarm/warning code of the last error that occurred.

| Index | Sub-index | Name       | Data Type | Access | PDO Mapping | Value | Saving to EEPROM |
|-------|-----------|------------|-----------|--------|-------------|-------|------------------|
| 603Fh | 0         | Error code | UINT      | RO     | Yes         | 0     | No               |

## Control word (A: 6040h, B: 6840h)

This object controls the device and operation mode.

| Index | Sub-index | Name         | Data Type | Access | PDO Mapping | Value                    | Saving to EEPROM |
|-------|-----------|--------------|-----------|--------|-------------|--------------------------|------------------|
| 6040h | 0         | Control word | UINT      | RW     | Yes         | 0 to 0xFFFF (default: 0) | No               |

### ◆ Control word Bits

| Bit      | Function                | Description   |
|----------|-------------------------|---|
| 0        | Switch on               | Refer to ■ <i>Details on Bits 0 to 3.</i>   |
| 1        | Enable voltage          |   |
| 2        | Quick stop              |   |
| 3        | Enable operation        |   |
| 4 to 6   | Operation mode specific | Refer to ■ <i>Details on Bits 4 to 9.</i>   |
| 7        | Fault reset             | 0 → 1: Alarm/warning reset.   |
| 8        | Halt                    | Refer to ■ <i>Details on Bits 4 to 9.</i>   |
| 9        | Operation mode specific |   |
| 10       | – (Reserved)            | –   |
| 11       | Positive torque limit   | 0: Disables <i>torque limit parameter</i> (object 2404h).<br>1: Enables <i>torque limit parameter</i> (object 2404h). |
| 12       | Negative torque limit   | 0: Disables <i>torque limit parameter</i> (object 2405h).<br>1: Enables <i>torque limit parameter</i> (object 2405h). |
| 13 to 15 | – (Reserved)            | –   |

### ■ Details on Bits 0 to 3

- Bits 0 to 3: These bits function as the control command for the Servo Drive's state.

| Command                      | Control word Bits |       |       |       |       |
|------------------------------|-------------------|-------|-------|-------|-------|
|                              | Bit 7             | Bit 3 | Bit 2 | Bit 1 | Bit 0 |
| Shutdown                     | 0                 | X     | 1     | 1     | 0     |
| Switch on                    | 0                 | 0     | 1     | 1     | 1     |
| Switch on + Enable operation | 0                 | 1     | 1     | 1     | 1     |
| Disable voltage              | 0                 | X     | X     | 0     | X     |
| Quick stop                   | 0                 | X     | 0     | 1     | X     |
| Disable operation            | 0                 | 0     | 1     | 1     | 1     |
| Enable operation             | 0                 | 1     | 1     | 1     | 1     |

### ■ Details on Bits 4 to 9

#### • Bits 4, 5, and 9: Profile Position Mode

| Bit 9 | Bit 5 | Bit 4 | Description   |
|-------|-------|-------|---|
| 0     | 0     | 0 → 1 | Starts the next positioning operation after the current positioning operation is completed (i.e., after the target is reached).       |
| X     | 1     | 0 → 1 | Starts the next positioning operation immediately.  |
| 1     | 0     | 0 → 1 | Continues positioning with the current profile speed up to the current target position and then start the next positioning operation. |

#### • Bits 6 and 8: Profile Position Mode

| Bit | Function | Value | Description  |
|-----|----------|-------|--|
| 6   | Abs/rel  | 0     | Treats the target position as an absolute value.   |
|     |          | 1     | Treats the target position as a relative value. (Treats it as the movement distance from the current target position.) |
| 8   | Halt     | 0     | Executes or continues positioning.   |
|     |          | 1     | Stops axis according to <i>halt option code</i> (605Dh).   |

#### • Bits 4, 5, 6, 8, and 9: Homing Mode

| Bit | Function               | Value | Description  |
|-----|------------------------|-------|--|
| 4   | Homing operation start | 0     | Does not start homing.                                       |
|     |                        | 1     | Starts or continues homing.                                  |
| 5   | –                      | 0     | Reserved.  |
| 6   | –                      | 0     | Reserved.  |
| 8   | Halt                   | 0     | Enables bit 4.   |
|     |                        | 1     | Stops the axis according to <i>halt option code</i> (605Dh). |
| 9   | –                      | 0     | Reserved.  |

#### • Bits 4, 5, 6, 8, and 9: Cyclic Synchronous Position, Velocity, or Torque Mode

| Bit | Function | Value | Description  |
|-----|----------|-------|--|
| 4   | –        | 0     | Reserved.  |
| 5   | –        | 0     | Reserved.  |
| 6   | –        | 0     | Reserved.  |
| 8   | Halt     | 0     | Executes or continues operation.                         |
|     |          | 1     | Stops axis according to <i>halt option code</i> (605Dh). |
| 9   | –        | 0     | Reserved.  |

#### • Bits 4, 5, 6, 8, and 9: Interpolated Position Mode

| Bit | Function             | Value | Description  |
|-----|----------------------|-------|--|
| 4   | Enable interpolation | 0     | Disables interpolation.                                      |
|     |                      | 1     | Enables interpolation.                                       |
| 5   | –                    | 0     | Reserved.  |
| 6   | –                    | 0     | Reserved.  |
| 8   | Halt                 | 0     | Executes specification for bit 4.                            |
|     |                      | 1     | Stops the axis according to <i>halt option code</i> (605Dh). |
| 9   | –                    | 0     | Reserved.  |

#### • Bits 4, 5, 6, 8, and 9: Profile Velocity/Torque Mode

| Bit | Function | Value | Description  |
|-----|----------|-------|--|
| 4   | –        | 0     | Reserved.  |
| 5   | –        | 0     | Reserved.  |
| 6   | –        | 0     | Reserved.  |
| 8   | Halt     | 0     | Executes or continues operation.                             |
|     |          | 1     | Stops the axis according to <i>halt option code</i> (605Dh). |
| 9   | –        | 0     | Reserved.  |

## Status word (A: 6041h, B: 6841h)

Status word contains the bits that give the current state of the Servo Drive and the operating state of the operation mode.

| Index | Sub-index | Name        | Data Type | Access | PDO Mapping | Value | Saving to EEPROM |
|-------|-----------|-------------|-----------|--------|-------------|-------|------------------|
| 6041h | 0         | Status word | UINT      | RO     | Yes         | 0     | No               |

### ◆ Status word Bits

| Bit    | State                   | Description   |
|--------|-------------------------|---|
| 0      | Ready to switch on      | Refer to ■ Details on Bits 0 to 7.                          |
| 1      | Switched on             |   |
| 2      | Operation enabled       |   |
| 3      | Fault                   |   |
| 4      | Voltage enabled         |   |
| 5      | Quick stop              |   |
| 6      | Switch on disabled      |   |
| 7      | Warning                 |   |
| 8      | Active mode stop        | 1: Active mode function execution is in progress.           |
| 9      | Remote                  | Control word (6040h) is being processed                     |
| 10     | Operation mode specific | Refer to ■ Details on Bits 10, 12, and 13.                  |
| 11     | Internal limit active   | Refer to ■ Details on Bit 11.                               |
| 12, 13 | Operation mode specific | Refer to ■ Details on Bits 10, 12, and 13.                  |
| 14     | Torque limit active     | 0: Torque limit is disabled.<br>1: Torque limit is enabled. |
| 15     | Safety active           | 1: Safety function is active.                               |

### ■ Details on Bits 0 to 7

#### • Bits 0 to 7: Current State of Servo Drive

| Bit 7 | Bit 6 | Bit 5 | Bit 4 | Bit 3 | Bit 2 | Bit 1 | Bit 0 | Servo Drive State      |
|-------|-------|-------|-------|-------|-------|-------|-------|------------------------|
| X     | 0     | X     | X     | 0     | 0     | 0     | 0     | Not ready to switch on |
| X     | 1     | X     | X     | 0     | 0     | 0     | 0     | Switch on disabled     |
| X     | 0     | 1     | X     | 0     | 0     | 0     | 1     | Ready to switch on     |
| X     | 0     | 1     | X     | 0     | 0     | 1     | 1     | Switched on            |
| X     | 0     | 1     | X     | 0     | 1     | 1     | 1     | Operation enabled      |
| X     | 0     | 0     | X     | 0     | 1     | 1     | 1     | Quick stop active      |
| X     | 0     | X     | X     | 1     | 1     | 1     | 1     | Fault reaction active  |
| X     | 0     | X     | X     | 1     | 0     | 0     | 0     | Fault                  |
| X     | X     | X     | 1     | X     | X     | X     | X     | Main power on          |
| 1     | X     | X     | X     | X     | X     | X     | X     | Warning occurred       |

### ■ Details on Bit 11

#### • Bit 11: Internal limit active

The internal limit is activated in the following cases:

- The target position was limited by a software limit.
- The N-OT or P-OT signal was activated.
- The interpolation speed was exceeded in Interpolated Position Mode or Cyclic Position Mode.

If the interpolated reference speed exceeds the following speed range, the target position will be ignored.

$$\frac{(\text{Target position} - \text{position demand value}) \times (2701\text{h: } 01) / (2701\text{h: } 02)}{\text{Interpolation time period}} < 4,194,304 \text{ [inc/ms]}$$

■ Details on Bits 10, 12, and 13

• Bits 10, 12, and 13: Profile Position Mode

| Bit | Meaning               | Value | Description  |
|-----|-----------------------|-------|--|
| 10  | Target reached        | 0     | <i>Halt</i> (bit 8 in <i>control word</i> ) = 0: The target position has not been reached.<br><i>Halt</i> (bit 8 in <i>control word</i> ) = 1: The axis is decelerating. |
|     |                       | 1     | <i>Halt</i> (bit 8 in <i>control word</i> ) = 0: The target position was reached.<br><i>Halt</i> (bit 8 in <i>control word</i> ) = 1: The axis is stopped.               |
| 12  | Set-point acknowledge | 0     | Processing of previous set point (reference) was completed and Servo Drive is waiting for a new set point.   |
|     |                       | 1     | Processing the previous set point is still in process or a set point was acknowledged.   |
| 13  | Following error       | 0     | No following error has occurred.   |
|     |                       | 1     | A following error occurred.  |

• Bits 10, 12, and 13: Homing Mode

| Bit 13       | Bit 12          | Bit 10         | Description  |
|--------------|-----------------|----------------|--|
| Homing error | Homing attained | Target reached |  |
| 0            | 0               | 0              | Homing is in progress.   |
| 0            | 0               | 1              | Homing was interrupted or has not yet started.                 |
| 0            | 1               | 0              | Home has been defined, but the operation is still in progress. |
| 0            | 1               | 1              | Homing was completed normally.                                 |
| 1            | 0               | 0              | A homing error occurred and the speed is not 0.                |
| 1            | 0               | 1              | A homing error occurred and the speed is 0.                    |

• Bits 10, 12, and 13: Cyclic Synchronous Position, Velocity, or Torque Mode

| Bit | State                | Value | Description  |
|-----|----------------------|-------|--|
| 10  | Target reached       | 0     | The target (position, speed, or torque) has not been reached (always 0 in Cyclic Torque Mode). |
|     |                      | 1     | The target (position, speed, or torque) was reached.   |
| 12  | Target value ignored | 0     | The target value (position, speed, or torque) was disabled.                                    |
|     |                      | 1     | Target value (position, speed, or torque) was enabled.   |
| 13  | Following error      | 0     | There is no following error (always 0 in Cyclic Velocity or Torque Mode).                      |
|     |                      | 1     | A following error occurred.  |

• Bits 10, 12, and 13: Interpolated Position Mode

| Bit | State          | Value | Description  |
|-----|----------------|-------|--|
| 10  | Target reached | 0     | <i>Halt</i> (bit 8 in <i>control word</i> ) = 0: The target position has not been reached.<br><i>Halt</i> (bit 8 in <i>control word</i> ) = 1: The axis is decelerating. |
|     |                | 1     | <i>Halt</i> (bit 8 in <i>control word</i> ) = 0: The target position was reached.<br><i>Halt</i> (bit 8 in <i>control word</i> ) = 1: The axis is stopped.               |
| 12  | Ip mode active | 0     | Interpolation is disabled.   |
|     |                | 1     | Interpolation is enabled.  |
| 13  | –              | 0     | Reserved.  |

• Bits 10, 12, and 13: Profile Velocity Mode

| Bit | State          | Value | Description   |
|-----|----------------|-------|---|
| 10  | Target reached | 0     | <i>Halt</i> (bit 8 in <i>control word</i> ) = 0: The target speed has not been reached.<br><i>Halt</i> (bit 8 in <i>control word</i> ) = 1: The axis is decelerating. |
|     |                | 1     | <i>Halt</i> (bit 8 in <i>control word</i> ) = 0: The target speed was reached.<br><i>Halt</i> (bit 8 in <i>control word</i> ) = 1: The axis is stopped.               |
| 12  | Speed          | 0     | The speed is not 0.   |
|     |                | 1     | The speed is 0.   |
| 13  | –              | 0     | Reserved.   |

• Bits 10, 12, and 13: Profile Torque Mode

| Bit | State          | Value | Description  |
|-----|----------------|-------|--|
| 10  | Target reached | 0     | <i>Halt</i> (bit 8 in <i>control word</i> ) = 0: The target torque has not been reached.<br><i>Halt</i> (bit 8 in <i>control word</i> ) = 1: The axis is decelerating. |
|     |                | 1     | <i>Halt</i> (bit 8 in <i>control word</i> ) = 0: The target torque was reached.<br><i>Halt</i> (bit 8 in <i>control word</i> ) = 1: The axis is stopped.               |
| 12  | –              | 0     | Reserved.  |
| 13  | –              | 0     | Reserved.  |

### Quick Stop Option Code (A: 605Ah, B: 685Ah)

This object determines what operation will be performed if a Quick Stop is executed.

| Index | Sub-index | Name                   | Data Type | Access | PDO Mapping | Value               | Saving to EEPROM |
|-------|-----------|------------------------|-----------|--------|-------------|---------------------|------------------|
| 605Ah | 0         | Quick stop option code | INT       | RW     | No          | 0 to 4 (default: 2) | Yes              |

#### ◆ Data Description

| Value | Description   |
|-------|---|
| 0     | Disables the Servo Drive (moves to the Switch ON Disabled state).   |
| 1     | Decelerates at the deceleration rate for decelerating to a stop and moves to the Switch ON Disabled state.*1,*2 |
| 2     | Decelerates at the deceleration rate for a quick stop and moves to the Switch ON Disabled state.*1,*3           |
| 3     | Decelerates at the torque limit and moves to the Switch ON Disabled state.*1                                    |

\*1. The motor is always stopped according to option code 0 (servo OFF stop) in Profile Torque Mode or Cyclic Torque Mode.

\*2. The deceleration rate for decelerating to a stop is defined in the following object.  
 • Profile Position, Interpolated Position, Cyclic Position, or Cyclic Velocity Mode: 6084h  
 • Homing Mode: 609Ah

\*3. *Quick stop deceleration* (6085h) is the deceleration rate for a quick stop.

### Shutdown Option Code (A: 605Bh, B: 685Bh)

This object defines the operation that is performed if there is a move from Operation Enable state to Ready to Switch ON state.

| Index | Sub-index | Name                 | Data Type | Access | PDO Mapping | Value               | Saving to EEPROM |
|-------|-----------|----------------------|-----------|--------|-------------|---------------------|------------------|
| 605Bh | 0         | Shutdown option code | INT       | RW     | No          | 0 to 1 (default: 0) | Yes              |

### ◆ Data Description

| Value | Description   |
|-------|---|
| 0     | Disables the Servo Drive (moves to the Switch ON Disabled state).   |
| 1     | Decelerates at the deceleration rate for decelerating to a stop and moves to the Switch ON Disabled state. *1, *2 |

\*1. The motor is always stopped according to option code 0 (servo OFF stop) in Profile Torque Mode or Cyclic Torque Mode.

\*2. The deceleration rate for decelerating to a stop is defined in the following object.

- Profile Position, Interpolated Position, Cyclic Position, or Cyclic Velocity Mode: 6084h
- Homing Mode: 609Ah

## Disable Operation Option Code (A: 605Ch, B: 685Ch)

This object defines the operation that is performed if there is a move from Operation Enable state to Switched ON state.

| Index | Sub-index | Name                          | Data Type | Access | PDO Mapping | Value               | Saving to EEPROM |
|-------|-----------|-------------------------------|-----------|--------|-------------|---------------------|------------------|
| 605Ch | 0         | Disable operation option code | INT       | RW     | No          | 0 to 1 (default: 1) | Yes              |

### ◆ Data Description

| Value | Description   |
|-------|---|
| 0     | Disables the Servo Drive (moves to the Switch ON Disabled state).   |
| 1     | Decelerates at the deceleration rate for decelerating to a stop and moves to the Switch ON Disabled state. *1, *2 |

\*1. The motor is always stopped according to option code 0 (servo OFF stop) in Profile Torque Mode or Cyclic Torque Mode.

\*2. The deceleration rate for decelerating to a stop is defined in the following object.

- Profile Position, Interpolated Position, Cyclic Position, or Cyclic Velocity Mode: 6084h
- Homing Mode: 609Ah

## Halt Option Code (A: 605Dh, B: 685Dh)

This object defines the operation that is performed if bit 8 (Halt) in *control word* is active.

| Index | Sub-index | Name             | Data Type | Access | PDO Mapping | Value               | Saving to EEPROM |
|-------|-----------|------------------|-----------|--------|-------------|---------------------|------------------|
| 605Dh | 0         | Halt option code | INT       | RW     | No          | 0 to 4 (default: 1) | Yes              |

### ◆ Data Description

| Value | Description  |
|-------|--|
| 1     | Decelerates at the deceleration rate for decelerating to a stop and moves to the Operation Enabled state. *1, *2 |
| 2     | Decelerates at the deceleration rate for a quick stop and moves to the Operation Enabled state. *1, *3           |
| 3     | Decelerates at the torque limit and moves to the Operation Enabled state. *1                                     |

\*1. If bit 8 (Halt) of *control word* is 1 in Profile Torque Mode or Cyclic Torque Mode, the torque reference value is reduced to zero.

\*2. The deceleration rate for decelerating to a stop is defined in the following object.

- Profile Position, Interpolated Position, Cyclic Position, or Cyclic Velocity Mode: 6084h
- Homing Mode: 609Ah

\*3. *Quick stop deceleration* (6085h) is the deceleration rate for a quick stop.

## Fault Reaction Option Code (A: 605Eh, B: 685Eh)

This object defines the operation that is performed when an alarm is detected in the Servo Drive system.

| Index | Sub-index | Name                       | Data Type | Access | PDO Mapping | Value | Saving to EEPROM |
|-------|-----------|----------------------------|-----------|--------|-------------|-------|------------------|
| 605Eh | 0         | Fault reaction option code | INT       | RW     | No          | 0     | Yes              |

### ◆ Data Description

| Value | Description                                      |
|-------|--|
| 0     | Disables the Servo Drive. (Turns OFF the servo.) |

## Modes of Operation (A: 6060h, B: 6860h)

This object is used to select the operation mode. The Servo Drive gives the actual operation mode in the *modes of operation display* object.

| Index | Sub-index | Name               | Data Type | Access | PDO Mapping | Value                | Saving to EEPROM |
|-------|-----------|--------------------|-----------|--------|-------------|----------------------|------------------|
| 6060h | 0         | Modes of operation | SINT      | RW     | Yes         | 0 to 10 (default: 0) | Yes              |

### ◆ Data Description

| Value       | Description                                  |
|-------------|--|
| 0           | There is no mode change or no mode assigned. |
| 1           | Profile Position Mode                        |
| 2           | Reserved (continue previous mode).           |
| 3           | Profile Velocity Mode                        |
| 4           | Torque Profile mode                          |
| 6           | Homing Mode                                  |
| 7           | Interpolated Position Mode                   |
| 8           | Cyclic Sync Position Mode                    |
| 9           | Cyclic Sync Velocity Mode                    |
| 10          | Cyclic Sync Torque Mode                      |
| Other value | Reserved (continue previous mode).           |

## Modes of Operation Display (A: 6061h, B: 6861h)

This object gives the current mode of operation.

The values that are returned are the same as the object codes for *modes of operation* (6060h).

| Index | Sub-index | Name                       | Data Type | Access | PDO Mapping | Value | Saving to EEPROM |
|-------|-----------|----------------------------|-----------|--------|-------------|-------|------------------|
| 6061h | 0         | Modes of operation display | SINT      | RO     | Yes         | 0     | No               |



## Supported Drive Modes (A: 6502h, B: 6D02h)

This object gives the operation modes that are supported by the device.

| Index | Subindex | Name                  | Data Type | Access | PDO Mapping | Value | Saving to EEPROM |
|-------|----------|-----------------------|-----------|--------|-------------|-------|------------------|
| 6502h | 0        | Supported drive modes | UDINT     | RO     | No          | 03EDh | No               |

### ◆ Data Description

| Bit      | Applicable Mode                 | Definition        |
|----------|---------------------------------|-------------------|
| 0        | Pp (Profile position mode)      | 1: Supported.     |
| 1        | Vl (Velocity mode)              | 0: Not supported. |
| 2        | Pv (Profile velocity mode)      | 1: Supported.     |
| 3        | Tq (Torque profile mode)        | 1: Supported.     |
| 4        | Reserved.                       | 0                 |
| 5        | Hm (Homing mode)                | 1: Supported.     |
| 6        | Ip (Interpolated position mode) | 1: Supported.     |
| 7        | Csp (Cyclic sync position mode) | 1: Supported.     |
| 8        | Csv (Cyclic sync velocity mode) | 1: Supported.     |
| 9        | Cst (Cyclic sync torque mode)   | 1: Supported.     |
| 10 to 31 | Reserved.                       | 0                 |

## 14.8 Profile Position Mode

### Target Position (A: 607Ah, B: 687Ah)

This object contains the target position for the Profile Position Mode or Cyclic Synchronous Position Mode.

In Profile Position Mode, the value of this object is interpreted as either an absolute or relative value depending on the Abs/Rel Flag in *control word*. In Cyclic Synchronous Position Mode, the value is always interpreted as an absolute value.

| Index | Sub-index | Name            | Data Type | Access | PDO Mapping | Value  | Saving to EEPROM |
|-------|-----------|-----------------|-----------|--------|-------------|--|------------------|
| 607Ah | 0         | Target position | DINT      | RW     | Yes         | -2,147,483,648 to 2,147,483,647 (default: 0) [Pos. unit] | No               |

### Software Position Limits (A: 607Dh, B: 687Dh)

This object defines the absolute positions of the limits to the target position (*position demand value*). Every target position is checked against these limits.

The limit positions are specified in user-defined position reference units, the same as for target positions, and are always relative to the machine home position.

The limit values are corrected internally for the *home offset* as given below. The target positions are compared with the corrected values.

- Corrected minimum position limit = Min position limit – Home offset (607Ch)
- Corrected maximum position limit = Max position limit – Home offset (607Ch)

The software position limits are enabled at the following times:

- When homing is completed
- When an absolute encoder is connected

The software limits are disabled if they are set as follows:

- Min position limit  $\geq$  Max position limit

| Index | Sub-index | Name               | Data Type | Access | PDO Mapping | Value  | Saving to EEPROM |
|-------|-----------|--------------------|-----------|--------|-------------|--|------------------|
| 607Dh | 0         | Number of entries  | USINT     | RO     | No          | 2  | No               |
|       | 1         | Min position limit | DINT      | RW     | No          | -536,870,912 to 536,870,911 (default: 0) [Pos. unit] | Yes              |
|       | 2         | Max position limit | DINT      | RW     | No          | -536,870,912 to 536,870,911 (default: 0) [Pos. unit] | Yes              |

### Max Profile Velocity (A: 607Fh, B: 687Fh)

This object contains the maximum speed during a Profile Mode operation.

| Index | Sub-index | Name                 | Data Type | Access | PDO Mapping | Value   | Saving to EEPROM |
|-------|-----------|----------------------|-----------|--------|-------------|---|------------------|
| 607Fh | 0         | Max profile velocity | UDINT     | RW     | Yes         | 0 to 4,294,967,295 (default: 2,147,483,647) [Vel. unit] | Yes              |

## Profile Velocity (A: 6081h, B: 6881h)

This object contains the final movement speed at the end of acceleration for a Profile Mode operation.

| Index | Subindex | Name             | Data Type | Access | PDO Mapping | Value                                       | Saving to EEPROM |
|-------|----------|------------------|-----------|--------|-------------|---|------------------|
| 6081h | 0        | Profile velocity | UDINT     | RW     | Yes         | 0 to 4,294,967,295 (default: 0) [Vel. unit] | Yes              |

## Profile Acceleration (A: 6083h, B: 6883h)

This object specifies the acceleration rate for Profile Mode operations.

| Index | Subindex | Name                 | Data Type | Access | PDO Mapping | Value   | Saving to EEPROM |
|-------|----------|----------------------|-----------|--------|-------------|---|------------------|
| 6083h | 0        | Profile acceleration | UDINT     | RW     | Yes         | 0 to 4,294,967,295 (default: 1,000) [Acc. unit] | Yes              |

## Profile Deceleration (A: 6084h, B: 6884h)

This object specifies the deceleration rate for Profile Mode operations.

| Index | Subindex | Name                 | Data Type | Access | PDO Mapping | Value   | Saving to EEPROM |
|-------|----------|----------------------|-----------|--------|-------------|---|------------------|
| 6084h | 0        | Profile deceleration | UDINT     | RW     | Yes         | 0 to 4,294,967,295 (default: 1,000) [Acc. unit] | Yes              |

## Quick Stop Deceleration (A: 6085h, B: 6885h)

This object contains the deceleration rate that is used to stop the motor if the *quick stop option code* (605Ah) is set to 2 and the Quick Stop command is given.

| Index | Subindex | Name                    | Data Type | Access | PDO Mapping | Value   | Saving to EEPROM |
|-------|----------|-------------------------|-----------|--------|-------------|---|------------------|
| 6085h | 0        | Quick stop deceleration | UDINT     | RW     | Yes         | 0 to 4,294,967,295 (default: 1,000) [Acc. unit] | Yes              |

## 14.9 Homing Mode

### Home Offset (A: 607Ch, B: 687Ch)

This object contains the offset between the zero position for the application and the machine home position (found during homing).

| Index | Sub-index | Name        | Data Type | Access | PDO Mapping | Value  | Saving to EEPROM |
|-------|-----------|-------------|-----------|--------|-------------|--|------------------|
| 607Ch | 0         | Home offset | DINT      | RW     | No          | -536,870,912 to 536,870,911 (default: 0) [Pos. unit] | Yes              |

- **Incremental Encoder**

The machine home position is found during homing. After homing is completed, the zero position is offset from the home position by adding the home offset to the home position.

- **Absolute Encoder**

If an absolute encoder is connected to the SERVOPACK, the home offset is added to the encoder absolute position when the power supply to the SERVOPACK is turned ON.



### Homing Method (A: 6098h, B: 6898h)

This object specifies the homing method. Refer to the following section for details on the operations that are performed.

13.4 Homing on page 13-14

| Index | Sub-index | Name          | Data Type | Access | PDO Mapping | Value                 | Saving to EEPROM |
|-------|-----------|---------------|-----------|--------|-------------|-----------------------|------------------|
| 6098h | 0         | Homing method | SINT      | RW     | Yes         | 0 to 35 (default: 35) | No               |

#### ◆ Data Description

| Value (Method) | Description   |
|----------------|---|
| 0              | Homing is disabled.                                   |
| 1              | Homing with the negative limit switch and index pulse |
| 2              | Homing with the positive limit switch and index pulse |
| 7 to 14        | Homing with the home switch and index pulse           |
| 24             | Homing with the home switch                           |
| 28             | Homing with the home switch                           |
| 33 or 34       | Homing with the index pulse                           |
| 35             | Homing with the current position                      |

## Homing Speeds (A: 6099h, B: 6899h)

This object defines the speeds that are used during homing. The speeds are given in user speed reference units.

| Index | Subindex | Name                           | Data Type | Access | PDO Mapping | Value   | Saving to EEPROM |
|-------|----------|--------------------------------|-----------|--------|-------------|---|------------------|
| 6099h | 0        | Number of entries              | USINT     | RO     | No          | 2   | No               |
|       | 1        | Speed during search for switch | UDINT     | RW     | Yes         | 0 to 4,294,967,295 (default: 500,000) [Vel. unit] | Yes              |
|       | 2        | Speed during search for zero   | UDINT     | RW     | Yes         | 0 to 4,294,967,295 (default: 100,000) [Vel. unit] | Yes              |

## Homing Acceleration (A: 609Ah, B: 689Ah)

This object defines the acceleration that is used during homing. The rate is given in user acceleration reference units.

| Index | Subindex | Name                | Data Type | Access | PDO Mapping | Value   | Saving to EEPROM |
|-------|----------|---------------------|-----------|--------|-------------|---|------------------|
| 609Ah | 0        | Homing acceleration | UDINT     | RW     | Yes         | 0 to 4,294,967,295 (default: 1,000) [Acc. unit] | Yes              |

## 14.10 Position Control Function

### Position Demand Value (A: 6062h, B: 6862h)

This object specifies the current reference position in user position reference units.

| Index | Sub-index | Name                  | Data Type | Access | PDO Mapping | Value         | Saving to EEPROM |
|-------|-----------|-----------------------|-----------|--------|-------------|---------------|------------------|
| 6062h | 0         | Position demand value | DINT      | RO     | Yes         | – [Pos. unit] | No               |

### Position Actual Internal Value (A: 6063h, B: 6863h)

This object gives the current feedback position in encoder pulse units.

| Index | Sub-index | Name                           | Data Type | Access | PDO Mapping | Value   | Saving to EEPROM |
|-------|-----------|--------------------------------|-----------|--------|-------------|---------|------------------|
| 6063h | 0         | Position actual internal value | DINT      | RO     | Yes         | – [inc] | No               |

### Position Actual Value (A: 6064h, B: 6864h)

This object gives the current feedback position in user position reference units.

| Index | Sub-index | Name                  | Data Type | Access | PDO Mapping | Value         | Saving to EEPROM |
|-------|-----------|-----------------------|-----------|--------|-------------|---------------|------------------|
| 6064h | 0         | Position actual value | DINT      | RO     | Yes         | – [Pos. unit] | No               |

### Position Demand Internal Value (A: 60FCh, B: 68FCh)

This object gives the output of the trajectory generator during position control (the position that is input to the position loop). The value is given in encoder pulses.

| Index | Sub-index | Name                           | Data Type | Access | PDO Mapping | Value   | Saving to EEPROM |
|-------|-----------|--------------------------------|-----------|--------|-------------|---------|------------------|
| 60FCh | 0         | Position demand internal value | DINT      | RO     | Yes         | – [inc] | No               |

### Following Error Window (A: 6065h, B: 6865h)

This object defines the detection range for the following error (bit 13 of *status word*).

If the position deviation exceeds the *following error window* for the *following error time out* (6066h), bit 13 in *status word* changes to 1 to indicate following error. A following error can occur when the Servo Drive is blocked, when the profile speed is too high, or when the gain settings are not correct.

| Index | Sub-index | Name                   | Data Type | Access | PDO Mapping | Value   | Saving to EEPROM |
|-------|-----------|------------------------|-----------|--------|-------------|---|------------------|
| 6065h | 0         | Following error window | UDINT     | RW     | No          | 0 to 1,073,741,823<br>(default: 5,242,880)<br>[Pos. unit] | Yes              |

### Following Error Time Out (A: 6066h, B: 6866h)

If the position deviation exceeds the *following error window* for the time specified in this object, bit 13 in *status word* changes to 1 to indicate following error.

| Index | Sub-index | Name                     | Data Type | Access | PDO Mapping | Value                            | Saving to EEPROM |
|-------|-----------|--------------------------|-----------|--------|-------------|----------------------------------|------------------|
| 6066h | 0         | Following error time out | UINT      | RW     | No          | 0 to 65,535<br>(default: 0) [ms] | Yes              |

## Following Error Actual Value (A: 60F4h, B: 68F4h)

This object provides the current following error.

| Index | Sub-index | Name                         | Data Type | Access | PDO Mapping | Value         | Saving to EEPROM |
|-------|-----------|------------------------------|-----------|--------|-------------|---------------|------------------|
| 60F4h | 0         | Following error actual value | DINT      | RO     | Yes         | – [Pos. unit] | No               |

## Position Window (A: 6067h, B: 6867h)

This object defines the positioning completed width for the target position. When the Servo Drive has completed outputting the reference to the target position and the time specified in *position window time* (6068h) has passed after the distance between the target position and the *position actual value* is within the value of this object, bit 10 (*target reached*) in *status word* changes to 1.

| Index | Sub-index | Name            | Data Type | Access | PDO Mapping | Value  | Saving to EEPROM |
|-------|-----------|-----------------|-----------|--------|-------------|--|------------------|
| 6067h | 0         | Position window | UDINT     | RW     | No          | 0 to 1,073,741,823 (default: 30) [Pos. unit] | Yes              |

## Position Window Time (A: 6068h, B: 6868h)

When the Servo Drive has completed outputting the reference to the target position and the time specified in this object has passed after the distance between the target position and the *position actual value* is within the *position window* (6067h), bit 10 (*target reached*) in *status word* changes to 1.

| Index | Sub-index | Name                 | Data Type | Access | PDO Mapping | Value                         | Saving to EEPROM |
|-------|-----------|----------------------|-----------|--------|-------------|-------------------------------|------------------|
| 6068h | 0         | Position window time | UINT      | RW     | No          | 0 to 65,535 (default: 0) [ms] | Yes              |

## 14.11 Interpolated Position Mode

### Interpolation Submode Select (A: 60C0h, B: 68C0h) (Object Shared by Mode 1 and Mode 2)

This object is used to select the submode for the Interpolated Position Mode. To use Interpolated Position Mode, set this object first.

| Index | Subindex | Name                          | Data Type | Access | PDO Mapping | Value                | Saving to EEPROM |
|-------|----------|-------------------------------|-----------|--------|-------------|----------------------|------------------|
| 60C0h | 0        | Interpolation sub mode select | INT       | RW     | No          | -3 to 0 (default: 0) | No               |

#### ◆ Data Description

| Value (Method) | Description                                       |  |
|----------------|---|--|
| 0              | Selects mode 1 with no position reference filter. | <i>Interpolation data record</i> (60C1h) is used as the interpolation position reference.  |
| -1             | Selects mode 1 with a position reference filter.* |  |
| -2             | Selects mode 2 with no position reference filter. | <i>Interpolation data record for 1st profile</i> (27C0h) and <i>interpolation data record for 2nd profile</i> (27C1h) are used as the interpolation position references. |
| -3             | Selects mode 2 with a position reference filter.* |  |

\* If a reference filter is used, the moving average of the interpolation position over the *interpolation time period* (60C2h) is used.

### Interpolation Data Record (A: 60C1h, B: 68C1h) (Object Shared by Mode 1 and Mode 2)

This object gives the interpolation position reference for Interpolated Position Mode.

| Index | Subindex | Name                      | Data Type | Access | PDO Mapping | Value  | Saving to EEPROM |
|-------|----------|---------------------------|-----------|--------|-------------|--|------------------|
| 60C1h | 0        | Number of entries         | USINT     | RO     | No          | 1  | No               |
|       | 1        | Interpolation data record | DINT      | RW     | Yes         | -2,147,483,648 to 2,147,483,647 (default: 0) [Pos. unit] | No               |



## Interpolation Time Period (A: 60C2h, B: 68C2h) (Object Shared by Mode 1 and Mode 2)

This object defines the interpolated position reference period for Interpolation Position Mode. If DC Sync0 Mode is selected, the interpolation time period is automatically stored as the Sync0 Cycle Time. If DC Free-Run Mode is selected, set the object manually.

| Index | Sub-index | Name                            | Data Type | Access | PDO Mapping | Value                  | Saving to EEPROM |
|-------|-----------|---------------------------------|-----------|--------|-------------|------------------------|------------------|
| 60C2h | 0         | Number of entries               | USINT     | RO     | No          | 2                      | No               |
|       | 1         | Interpolation time period value | USINT     | RW     | No          | 1 to 250 (default:125) | No               |
|       | 2         | Interpolation time index        | SINT      | RW     | No          | -6 to -3 (default: -3) | No               |

Interpolation time = (Interpolation time period value (60C2h: 01))  $\times$  10<sup>Interpolation time index (60C2h: 02)</sup> [s]

Note: You can change this object only under the following conditions.

- When DC Sync0 Mode Is Selected:  
EtherCAT (CoE) is in the Switch ON Disable state.
- When DC Free-run Mode Is Selected:  
EtherCAT (CoE) is in the Switch ON Disable state.  
Or, EtherCAT (CoE) is in Interpolated Position Mode and *enable interpolation* equals 0.

## Manufacturer Interpolation Data Configuration for 1st Profile (A: 2730h, B: 2F30h) (Mode 2 Object)

This object sets how to use the interpolation position reference in *interpolation data record for 1st profile* (27C0h).

| Index | Sub-index                               | Name                     | Data Type | Access | PDO Mapping         | Value                 | Saving to EEPROM |
|-------|---|--------------------------|-----------|--------|---------------------|-----------------------|------------------|
| 2730h | 0                                       | Number of entries        | USINT     | RO     | No                  | 9                     | No               |
|       | 1                                       | Maximum buffer size      | UDINT     | RO     | No                  | 254                   | No               |
|       | 2                                       | Actual buffer size       | UDINT     | RW     | No                  | 254                   | No               |
|       | 3                                       | Buffer organization      | USINT     | RW     | No                  | 0 or 1 (default: 0)   | No               |
|       | 4                                       | Buffer position          | UINT      | RW     | Yes                 | 1 to 255 (default: 1) | No               |
|       | 5                                       | Size of data record      | USINT     | WO     | No                  | 1                     | No               |
|       | 6                                       | Buffer clear             | USINT     | WO     | No                  | 0 or 1 (default: 0)   | No               |
|       | 7                                       | Position data definition | USINT     | RW     | Yes                 | 0 or 1 (default: 1)   | No               |
|       | 8                                       | Position data polarity   | USINT     | RW     | Yes                 | 0 or 1 (default: 0)   | No               |
| 9     | Behavior after reaching buffer position | USINT                    | RW        | Yes    | 0 or 1 (default: 0) | No                    |                  |

### ◆ 2730h: 3 Buffer Organization

| Value (Method) | Description  |
|----------------|--|
| 0              | Uses the reference input buffer as a FIFO buffer.    |
| 1              | Uses the reference input buffer is as a ring buffer. |

Note: Do not change this value while *enable interpolation* (6040h bit 4) is 1.

### ◆ 2730h: 4 Buffer Position

The object contains the entry point for the available area in the reference input buffer.

Note: Do not change this value while *enable interpolation* (6040h bit 4) is 1.

### ◆ 2730h: 6 Buffer Clear

| Value (Method) | Description                          |
|----------------|--------------------------------------|
| 0              | Disables the reference input buffer. |
| 1              | Enables the reference input buffer.  |

### ◆ 2730h: 7 Position Data Definition

| Value (Method) | Description  |
|----------------|--|
| 0              | Uses the value in the reference input buffer as an absolute value. |
| 1              | Uses the value in the reference input buffer as a relative value.  |

To enable changing this value, set the write pointer (2741h: 2) and the read pointer (2741h: 1) to the same value.

### ◆ 2730h: 8 Position Data Polarity

| Value (Method) | Description   |
|----------------|---|
| 0              | Multiplies the value in the reference input buffer by 1.  |
| 1              | Multiplies the value in the reference input buffer by -1. |

This value is valid when *position data definition* (2730h: 7) is 1.

To enable changing this value, set the write pointer (2741h: 2) and the read pointer (2741h: 1) to the same value.

### ◆ 2730h: 9 Behavior after Reaching Buffer Position

| Value (Method) | Description   |
|----------------|---|
| 0              | Holds the value of the read pointer (2741h: 1) when the read pointer (2741h: 1) equals the write pointer (2741h: 2) and <i>enable interpolation</i> is 0.       |
| 1              | Initializes the value of the read pointer (2741h: 1) when the read pointer (2741h: 1) equals the write pointer (2741h: 2) and <i>enable interpolation</i> is 0. |

This value is valid when *buffer organization* (2731h: 3) is 0.

## Manufacturer Interpolation Data Configuration for 2nd Profile (A: 2731h, B: 2F31h) (Mode 2 Object)

This object sets how to use the interpolation position reference in *interpolation data record for 2nd profile* (27C1h).

| Index | Sub-index                               | Name                     | Data Type | Access | PDO Mapping         | Value                 | Saving to EEPROM |
|-------|---|--------------------------|-----------|--------|---------------------|-----------------------|------------------|
| 2731h | 0                                       | Number of entries        | USINT     | RO     | No                  | 9                     | No               |
|       | 1                                       | Maximum buffer size      | UDINT     | RO     | No                  | 254                   | No               |
|       | 2                                       | Actual buffer size       | UDINT     | RW     | No                  | 254                   | No               |
|       | 3                                       | Buffer organization      | USINT     | RW     | No                  | 0 or 1 (default: 0)   | No               |
|       | 4                                       | Buffer position          | UINT      | RW     | Yes                 | 1 to 254 (default: 1) | No               |
|       | 5                                       | Size of data record      | USINT     | WO     | No                  | 1                     | No               |
|       | 6                                       | Buffer clear             | USINT     | WO     | No                  | 0 or 1 (default: 0)   | No               |
|       | 7                                       | Position data definition | USINT     | RW     | Yes                 | 0 or 1 (default: 0)   | No               |
|       | 8                                       | Position data polarity   | USINT     | RW     | Yes                 | 0 or 1 (default: 0)   | No               |
| 9     | Behavior after reaching buffer position | USINT                    | RW        | Yes    | 0 or 1 (default: 0) | No                    |                  |

### ◆ 2731h: 3 Buffer Organization

| Value (Method) | Description  |
|----------------|--|
| 0              | Uses the reference input buffer as a FIFO buffer.    |
| 1              | Uses the reference input buffer is as a ring buffer. |

Note: Do not change this value while *enable interpolation* (6040h bit 4) is 1.

### ◆ 2731h: 4 Buffer Position

This object contains the entry point for the available area in the reference input buffer.

Note: Do not change this value while *enable interpolation* (6040h bit 4) is 1.

### ◆ 2731h: 6 Buffer Clear

| Value (Method) | Description                          |
|----------------|--------------------------------------|
| 0              | Disables the reference input buffer. |
| 1              | Enables the reference input buffer.  |

### ◆ 2731h: 7 Position Data Definition

| Value (Method) | Description  |
|----------------|--|
| 0              | Uses the value in the reference input buffer as an absolute value. |
| 1              | Uses the value in the reference input buffer as a relative value.  |

To enable changing this value, set the write pointer (2741h: 2) and the read pointer (2741h: 1) to the same value.

### ◆ 2731h: 8 Position Data Polarity

| Value (Method) | Description   |
|----------------|---|
| 0              | Multiplies the value in the reference input buffer by 1.  |
| 1              | Multiplies the value in the reference input buffer by -1. |

This value is valid when *position data definition* (2731h: 7) is 1.

To enable changing this value, set the write pointer (2741h: 2) and the read pointer (2741h: 1) to the same value.

### ◆ 2731h: 9 Behavior after Reaching Buffer Position

| Value (Method) | Description   |
|----------------|---|
| 0              | Holds the value of the read pointer (2741h: 1) when the read pointer (2741h: 1) equals the write pointer (2741h: 2) and <i>enable interpolation</i> is 0.       |
| 1              | Initializes the value of the read pointer (2741h: 1) when the read pointer (2741h: 1) equals the write pointer (2741h: 2) and <i>enable interpolation</i> is 0. |

This value is valid when *buffer organization* (2731h: 3) is 0.

## Interpolation Profile Select (A: 2732h, B: 2F32h) (Mode 2 Object)

This object is used to select the type of interpolation profile to use.

Change the interpolation profile only after execution of the current profile has been completed. You can change the object when *enable interpolation* (6040h bit 4) is 0.

| Index | Sub-index | Name                         | Data Type | Access | PDO Mapping | Value               | Saving to EEPROM |
|-------|-----------|------------------------------|-----------|--------|-------------|---------------------|------------------|
| 2732h | 0         | Interpolation profile select | USINT     | RW     | Yes         | 0 or 1 (default: 0) | No               |

### ◆ Data Description

| Value (Method) | Description  |
|----------------|--|
| 0              | Uses the 1st profile.<br>( <i>interpolation data record for 1st profile</i> (27C0h) and <i>manufacturer interpolation data configuration for 1st profile</i> (2730h) are enabled.) |
| 1              | Uses the 2nd profile.<br>( <i>interpolation data record for 2nd profile</i> (27C1h) and <i>manufacturer interpolation data configuration for 2nd profile</i> (2731h) are enabled.) |

Note: Do not change this value while *enable interpolation* (6040h bit 4) is 1.

## Interpolation Data Record for 1st Profile (A: 27C0h, B: 2FC0h) (Mode 2 Object)

This object is used to set the interpolation position reference for the 1st profile in Buffer Strategies for the Interpolated Position Mode.

Set this object only after setting all of the items in *manufacturer interpolation data configuration for 1st profile* (2730h).

After you set this object, set *enable interpolation* (6040h bit 4) to 1.

| Index | Sub-index | Name                             | Data Type | Access | PDO Mapping | Value                                       | Saving to EEPROM |
|-------|-----------|----------------------------------|-----------|--------|-------------|---|------------------|
| 27C0h | 0         | Number of entries                | USINT     | RO     | No          | 254   | No               |
|       | 1 to 254  | 1st set point to 254th set point | DINT      | RW     | No          | -2,147,483,648 to 2,147,483,647 (default:0) | No               |

## Interpolation Data Record for 2nd Profile (A: 27C1h, B: 2FC1h) (Mode 2 Object)

This object is used to set the interpolation position reference for the 2nd profile in Buffer Strategies for the Interpolated Position Mode.

Set this object only after setting all of the items in *manufacturer interpolation data configuration for 2nd profile* (2731h).

After you set this object, set *enable interpolation* (6040h bit 4) to 1.

| Index | Sub-index | Name                             | Data Type | Access | PDO Mapping | Value                                       | Saving to EEPROM |
|-------|-----------|----------------------------------|-----------|--------|-------------|---|------------------|
| 27C1h | 0         | Number of entries                | USINT     | RO     | No          | 254   | No               |
|       | 1 to 254  | 1st set point to 254th set point | DINT      | RW     | No          | -2,147,483,648 to 2,147,483,647 (default:0) | No               |

## Interpolation Data Read/Write Pointer Position Monitor (A: 2741h, B: 2F41h) (Mode 2 Object)

This object gives the current values of the read and write pointers for the reference input buffers in the EtherCAT (CoE) Network Module.

| Index | Subindex | Name                                      | Data Type | Access | PDO Mapping | Value    | Saving to EEPROM |
|-------|----------|---|-----------|--------|-------------|----------|------------------|
| 2741h | 0        | Number of entries                         | USINT     | RO     | No          | 2        | No               |
|       | 1        | Interpolation data read pointer position  | UINT      | RO     | Yes         | 1 to 254 | No               |
|       | 2        | Interpolation data write pointer position | UINT      | RO     | Yes         | 1 to 254 | No               |

### ◆ 2741h: 1 Interpolation Data Read Pointer Position

This object gives the current value of the read pointer for the reference input buffer in the EtherCAT (CoE) Network Module.

### ◆ 2741h: 2 Interpolation Data Write Pointer Position

This object gives the current value of the write pointer for the reference input buffer in the EtherCAT (CoE) Network Module.

## 14.12 Cyclic Synchronous Position Mode

### Velocity Offset (A: 60B1h, B: 68B1h)

In Cyclic Synchronous Position Mode, this object contains the speed feedforward value.

In Cyclic Synchronous Velocity Mode, this object contains the offset value to add to the speed reference.

| Index | Subindex | Name            | Data Type | Access | PDO Mapping | Value  | Saving to EEPROM |
|-------|----------|-----------------|-----------|--------|-------------|--|------------------|
| 60B1h | 0        | Velocity offset | DINT      | RW     | Yes         | -2,147,483,648 to 2,147,483,647 (default: 0) [Vel. unit] | No               |

### Torque Offset (A: 60B2h, B: 68B2h)

In Cyclic Synchronous Position Mode or Cyclic Synchronous Velocity Mode, this object contains the torque feedforward value. In Cyclic Synchronous Torque Mode, this object contains the offset value to add to the torque reference.

| Index | Subindex | Name          | Data Type | Access | PDO Mapping | Value                                 | Saving to EEPROM |
|-------|----------|---------------|-----------|--------|-------------|---------------------------------------|------------------|
| 60B2h | 0        | Torque offset | INT       | RW     | Yes         | -32,768 to 32,767 (default: 0) [0.1%] | No               |

## 14.13 Profile Velocity/Cyclic Synchronous Velocity Mode

### Velocity Demand Value (A: 606Bh, B: 686Bh)

This object contains the output value from the velocity trajectory generator or the output value from the position control function (i.e., the input reference for the speed loop).

| Index | Sub-index | Name                  | Data Type | Access | PDO Mapping | Value         | Saving to EEPROM |
|-------|-----------|-----------------------|-----------|--------|-------------|---------------|------------------|
| 606Bh | 0         | Velocity demand value | DINT      | RO     | Yes         | – [Vel. unit] | No               |

### Velocity Actual Value (A: 606Ch, B: 686Ch)

This object contains the motor speed.

| Index | Sub-index | Name                  | Data Type | Access | PDO Mapping | Value         | Saving to EEPROM |
|-------|-----------|-----------------------|-----------|--------|-------------|---------------|------------------|
| 606Ch | 0         | Velocity actual value | DINT      | RO     | Yes         | – [Vel. unit] | No               |

### Velocity Window (A: 606Dh, B: 686Dh)

This object sets the speed coincidence detection width.

When the time specified in *velocity window time* (606Eh) has passed after the difference between the target speed (*target velocity*) and the *velocity actual value* is within the setting of the *velocity window*, bit 10 (*target reached*) in *status word* is set to 1.

| Index | Sub-index | Name            | Data Type | Access | PDO Mapping | Value   | Saving to EEPROM |
|-------|-----------|-----------------|-----------|--------|-------------|---|------------------|
| 606Dh | 0         | Velocity window | UINT      | RW     | No          | 0 to 65,535<br>(default: 20,000)<br>[Vel. unit] | Yes              |

### Velocity Window Time (A: 606Eh, B: 686Eh)

When the time specified in *velocity window time* (606Eh) has passed after the difference between the target speed (*target velocity*) and the *velocity actual value* is within the setting of the *velocity window*, bit 10 (*target reached*) in *status word* is set to 1.

| Index | Sub-index | Name                 | Data Type | Access | PDO Mapping | Value                            | Saving to EEPROM |
|-------|-----------|----------------------|-----------|--------|-------------|----------------------------------|------------------|
| 606Eh | 0         | Velocity window time | UINT      | RW     | No          | 0 to 65,535<br>(default: 0) [ms] | Yes              |

### Target Velocity (A: 60FFh, B: 68FFh)

This object specifies the target speed for Profile Velocity Mode or Cyclic Synchronous Velocity Mode in user defined speed reference units.

| Index | Sub-index | Name            | Data Type | Access | PDO Mapping | Value  | Saving to EEPROM |
|-------|-----------|-----------------|-----------|--------|-------------|--|------------------|
| 60FFh | 0         | Target velocity | DINT      | RW     | Yes         | –2,147,483,648 to<br>2,147,483,647<br>(default: 0) [Vel. unit] | No               |

## 14.14 Profile Torque/Cyclic Synchronous Torque Mode

### Target Torque (A: 6071h, B: 6871h)

This object specifies the input torque reference value for Torque Control Mode. Set the value in units of 0.1% of the motor rated torque.

| Index | Subindex | Name          | Data Type | Access | PDO Mapping | Value                                 | Saving to EEPROM |
|-------|----------|---------------|-----------|--------|-------------|---------------------------------------|------------------|
| 6071h | 0        | Target torque | INT       | RW     | Yes         | -32,768 to 32,767 (default: 0) [0.1%] | No               |

### Torque Demand Value (A: 6074h, B: 6874h)

This object gives the currently output torque reference value. The value is given in units of 0.1% of the motor rated torque.

| Index | Subindex | Name                | Data Type | Access | PDO Mapping | Value    | Saving to EEPROM |
|-------|----------|---------------------|-----------|--------|-------------|----------|------------------|
| 6074h | 0        | Torque demand value | INT       | RO     | Yes         | - [0.1%] | No               |

### Torque Slope (A: 6087h, B: 6887h)

This object sets the torque output slope to use in Profile Torque Mode. Set the value as the rate of change per second (0.1%/s) in respect to the motor rated torque.

| Index | Subindex | Name         | Data Type | Access | PDO Mapping | Value                                       | Saving to EEPROM |
|-------|----------|--------------|-----------|--------|-------------|---|------------------|
| 6087h | 0        | Torque slope | UDINT     | RW     | Yes         | 0 to 4,294,967,295 (default:1,000) [0.1%/s] | Yes              |

### Motor Rated Torque (A: 6076h, B: 6876h)

This object gives the motor rated torque (rated force for a Linear Servomotor). The value is given in m·Nm for a Rotary Servomotor, and in m·N for a Linear Servomotor.

| Index | Subindex | Name               | Data Type | Access | PDO Mapping | Value          | Saving to EEPROM |
|-------|----------|--------------------|-----------|--------|-------------|----------------|------------------|
| 6076h | 0        | Motor rated torque | UDINT     | RO     | No          | -[mNm] or [mN] | No               |

### Torque Actual Value (A: 6077h, B: 6877h)

For a SERVOPACK, this object contains the same value as the torque reference output value.

| Index | Subindex | Name                | Data Type | Access | PDO Mapping | Value    | Saving to EEPROM |
|-------|----------|---------------------|-----------|--------|-------------|----------|------------------|
| 6077h | 0        | Torque actual value | INT       | RO     | Yes         | - [0.1%] | No               |



## 14.15 Torque Limit Function

### Max Torque (A: 6072h, B: 6872h)

This object sets the maximum output torque for the motor. Set the value in units of 0.1% of the motor rated torque.

The maximum motor torque is automatically set in this object when the power is turned ON.

| Index | Sub-index | Name       | Data Type | Access | PDO Mapping | Value   | Saving to EEPROM |
|-------|-----------|------------|-----------|--------|-------------|---|------------------|
| 6072h | 0         | Max torque | UINT      | RW     | Yes         | 0 to 65,535<br>(default: maximum motor torque) [0.1%] | No               |

### Positive Torque Limit Value (A: 60E0h, B: 68E0h)

This object sets the positive torque limit. Set the value in units of 0.1% of the motor rated torque.

| Index | Sub-index | Name                        | Data Type | Access | PDO Mapping | Value                                  | Saving to EEPROM |
|-------|-----------|-----------------------------|-----------|--------|-------------|--|------------------|
| 60E0h | 0         | Positive torque limit value | UINT      | RW     | Yes         | 0 to 65,535<br>(default: 8,000) [0.1%] | Yes              |

### Negative Torque Limit Value (A: 60E1h, B: 68E1h)

This object sets the negative torque limit. Set the value in units of 0.1% of the motor rated torque.

| Index | Sub-index | Name                        | Data Type | Access | PDO Mapping | Value                                  | EEPROM |
|-------|-----------|-----------------------------|-----------|--------|-------------|--|--------|
| 60E1h | 0         | Negative torque limit value | UINT      | RW     | Yes         | 0 to 65,535<br>(default: 8,000) [0.1%] | Yes    |

## 14.16 Touch Probe Function

### Touch Probe Function (A: 60B8h, B: 68B8h)

This object sets the touch probes.

| Index | Subindex | Name                 | Data Type | Access | PDO Mapping | Value                    | Saving to EEPROM |
|-------|----------|----------------------|-----------|--------|-------------|--------------------------|------------------|
| 60B8h | 0        | Touch probe function | UINT      | RW     | Yes         | 0 to 0xFFFF (default: 0) | No               |

#### ◆ Data Description

| Bit      | Value | Description  |
|----------|-------|--|
| 0        | 0     | Disables touch probe 1.  |
|          | 1     | Enables touch probe 1.   |
| 1        | 0     | Single Trigger Mode (Latches the position at the first trigger event.) |
|          | 1     | Continuous Trigger Mode (Latches the position every trigger event.)    |
| 2        | 0     | Triggers on probe 1 input (SERVOPACK CN1/Probe 1 (SI4) signal).        |
|          | 1     | Triggers on encoder zero signal (phase C).                             |
| 3        | –     | Reserved.  |
| 4        | 0     | Stops sampling at touch probe 1.                                       |
|          | 1     | Starts sampling at touch probe 1                                       |
| 5 to 7   | –     | Reserved.  |
| 8        | 0     | Disables touch probe 2.  |
|          | 1     | Enables touch probe 2.   |
| 9        | 0     | Single Trigger Mode (Latches the position at the first trigger event.) |
|          | 1     | Continuous Trigger Mode (Latches the position every trigger event.)    |
| 10       | 0     | Triggers on probe 2 input (SERVOPACK CN1/Probe 2 (SI5) signal).        |
|          | 1     | Reserved.  |
| 11       | –     | Reserved.  |
| 12       | 0     | Stops sampling at touch probe 2.                                       |
|          | 1     | Starts sampling at touch probe 2                                       |
| 13 to 15 | –     | Reserved.  |

Note: 1. Bits 0 to 7: For touch probe 1.

Bits 8 to 15: For touch probe 2.

2. Touch probe 1 cannot be used during execution of homing. If touch probe 1 was already enabled, it will be disabled when homing is started.

3. If 1 is specified for bit 1 (i.e., if Continuous Trigger Mode is set), the setting of bit 2 (Trigger Selection Signal) will be read each time the latch is started. To continuously latch with the same trigger signal, do not change the status of bit 2.

## Touch Probe Status (A: 60B9h, B: 68B9h)

This object gives the status of the touch probes.

| Index | Subindex | Name               | Data Type | Access | PDO Mapping | Value | Saving to EEPROM |
|-------|----------|--------------------|-----------|--------|-------------|-------|------------------|
| 60B9h | 0        | Touch probe status | UINT      | RO     | Yes         | –     | No               |

### ◆ Data Description

| Bit      | Value  | Description   |
|----------|--------|---|
| 0        | 0      | Touch probe 1 is disabled.  |
|          | 1      | Touch probe 1 is enabled.   |
| 1        | 0      | No latched position is stored for touch probe 1.  |
|          | 1      | A latch position is stored for touch probe 1.   |
| 2 to 6   | –      | Reserved.   |
| 7        | 0 or 1 | Saving the latched position for Continuous Trigger Mode for touch probe 1 was completed.*<br>(Status toggles every time a position is latched.) |
| 8        | 0      | Touch probe 2 is disabled.  |
|          | 1      | Touch probe 2 is enabled.   |
| 9        | 0      | No latched position is stored for touch probe 2.  |
|          | 1      | A latch position is stored for touch probe 2.   |
| 10 to 14 | –      | Reserved.   |
| 15       | 1      | Saving the latched position for Continuous Trigger Mode for touch probe 2 was completed.*<br>(Status toggles every time a position is latched.) |

\* If the continuous latch is enabled (60B8h bit 1 = 1 or bit 9 = 1), bit 7 or bit 15 of object 60B9h is toggled every time the latched position is updated.

## Touch Probe 1 Position Value (A: 60BAh, B: 68BAh)

This object gives the latched position for touch probe 1. The value is given in user position units (Pos. unit).

| Index | Subindex | Name                         | Data Type | Access | PDO Mapping | Value         | Saving to EEPROM |
|-------|----------|------------------------------|-----------|--------|-------------|---------------|------------------|
| 60BAh | 0        | Touch probe 1 position value | DINT      | RO     | Yes         | – [Pos. unit] | No               |

## Touch Probe 2 Position Value (A: 60BCh, B: 68BCh)

This object gives the latched position for touch probe 2. The value is given in user position units (Pos. unit).

| Index | Subindex | Name                         | Data Type | Access | PDO Mapping | Value         | Saving to EEPROM |
|-------|----------|------------------------------|-----------|--------|-------------|---------------|------------------|
| 60BCh | 0        | Touch probe 2 position value | DINT      | RO     | Yes         | – [Pos. unit] | No               |

## 14.17 Digital Inputs/Outputs

### Digital Inputs (A: 60FDh, B: 68FDh)

This object gives the status of the *digital inputs* to CN1 on the SERVOPACK.

| Index | Subindex | Name           | Data Type | Access | PDO Mapping | Value | Saving to EEPROM |
|-------|----------|----------------|-----------|--------|-------------|-------|------------------|
| 60FDh | 0        | Digital inputs | UDINT     | RO     | Yes         | –     | No               |

#### ◆ Data Description

| Bit      | Signal                      | Description   |
|----------|-----------------------------|---|
| 0        | N-OT: Negative limit switch | 0: OFF, 1: ON   |
| 1        | P-OT: Positive limit switch | 0: OFF, 1: ON   |
| 2        | Home switch                 | 0: OFF, 1: ON   |
| 3 to 15  | –                           | Reserved.   |
| 16       | SI0                         | Reserved.   |
| 17       | SI1                         | 0: OFF (open),<br>1: ON (closed)                            |
| 18       | SI2                         | 0: OFF (open),<br>1: ON (closed)                            |
| 19       | SI3                         | 0: OFF (open),<br>1: ON (closed)                            |
| 20       | SI4                         | 0: OFF (open),<br>1: ON (closed)                            |
| 21       | SI5                         | 0: OFF (open),<br>1: ON (closed)                            |
| 22       | SI6                         | Reserved.   |
| 23       | –                           | Reserved.   |
| 24       | HWBB1                       | Hardwired base block signal input 1<br>(0: Open, 1: Closed) |
| 25       | HWBB2                       | Hardwired base block signal input 2<br>(0: Open, 1: Closed) |
| 26 to 31 | –                           | Reserved.   |

## Digital Outputs (A: 60FEh, B: 68FEh)

This object controls the status of the general-purpose output signals (SO1 to SO5) from CN1 on the SERVOPACK.

Subindex 1 is used to control the status of the output signals. Subindex 2 determines which output signals in subindex 1 are enabled.

For objects 250Eh, 250Fh, 2510h, 2512h, 2514h, 25B0h to 25B8h, and 25BCh:

If SERVOPACK status outputs are assigned to the SO1 to SO5 signals in the above objects, the status will be output using ORs with the settings in this object. If any of these signals (SO1 to SO5) are assigned to functions that are enabled with the above objects, use the Bit Masks in subindex 2 to disable the corresponding signals so that the signals are not duplicated.

| Index | Sub-index | Name                           | Data Type | Access | PDO Mapping | Value                                 | Saving to EEPROM |
|-------|-----------|--------------------------------|-----------|--------|-------------|---------------------------------------|------------------|
| 60FEh | 0         | Number of entries              | USINT     | RO     | No          | 2                                     | No               |
|       | 1         | Physical outputs* <sup>1</sup> | UDINT     | RW     | Yes         | 0 to 0xFFFFFFFF (default: 0)          | No               |
|       | 2         | Bit mask* <sup>2</sup>         | UDINT     | RW     | No          | 0 to 0xFFFFFFFF (default: 0x000C0000) | Yes              |

\*1. Data Description of Physical Outputs:

| Bit      | Signal | Description   |
|----------|--------|---------------|
| 0 to 16  | –      | Reserved.     |
| 17       | SO1    | 0: OFF, 1: ON |
| 18       | SO2    | 0: OFF, 1: ON |
| 19       | SO3    | 0: OFF, 1: ON |
| 20       | SO4    | 0: OFF, 1: ON |
| 21       | SO5    | 0: OFF, 1: ON |
| 22 to 31 | –      | Reserved.     |

\*2. Data Description of Bit Masks:

| Bit      | Signal | Description   |
|----------|--------|---|
| 0 to 16  | –      | Reserved.   |
| 17       | SO1    | 0: Disables physical output.<br>1: Enables physical output. |
| 18       | SO2    | 0: Disables physical output.<br>1: Enables physical output. |
| 19       | SO3    | 0: Disables physical output.<br>1: Enables physical output. |
| 20       | SO4    | 0: Disables physical output.<br>1: Enables physical output. |
| 21       | SO5    | 0: Disables physical output.<br>1: Enables physical output. |
| 22 to 31 | –      | Reserved.   |



# Maintenance

---

# 15

This chapter provides information on the meaning of, causes of, and corrections for alarms and warnings.

## **15.1 Inspections and Part Replacement . . . . . 15-2**

- 15.1.1 Inspections . . . . . 15-2
- 15.1.2 Guidelines for Part Replacement . . . . . 15-2
- 15.1.3 Replacing the Battery . . . . . 15-3

## **15.2 Alarm Displays . . . . . 15-5**

- 15.2.1 List of Alarms . . . . . 15-5
- 15.2.2 Troubleshooting Alarms . . . . . 15-11
- 15.2.3 Resetting Alarms . . . . . 15-41
- 15.2.4 Displaying the Alarm History . . . . . 15-42
- 15.2.5 Clearing the Alarm History . . . . . 15-43
- 15.2.6 Resetting Motor Type Alarms . . . . . 15-44

## **15.3 Warning Displays . . . . . 15-46**

- 15.3.1 List of Warnings . . . . . 15-46
- 15.3.2 Troubleshooting Warnings . . . . . 15-47

## **15.4 Troubleshooting Based on the Operation and Conditions of the Servomotor . .15-53**

# 15.1 Inspections and Part Replacement

This section describes inspections and part replacement for SERVOPACKs.

## 15.1.1 Inspections

Perform the inspections given in the following table at least once every year for the SERVO-PACK. Daily inspections are not required.

| Item         | Frequency            | Inspection   | Correction                                     |
|--------------|----------------------|--|--|
| Exterior     | At least once a year | Check for dust, dirt, and oil on the surfaces.                                 | Clean with compressed air or a cloth.          |
| Loose Screws |                      | Check for loose terminal block and connector screws and for other loose parts. | Tighten any loose screws or other loose parts. |

## 15.1.2 Guidelines for Part Replacement

The following electric or electronic parts are subject to mechanical wear or deterioration over time. Use one of the following methods to check the standard replacement period.

- Use the service life prediction function of the SERVOPACK.  
Refer to the following section for information on service life predictions.

 10.4 Monitoring Product Life on page 10-14

- Use the following table.

| Part                                  | Standard Replacement Period    | Remarks   |
|---------------------------------------|--------------------------------|---|
| Cooling Fan                           | 4 to 5 years                   | The standard replacement periods given on the left are for the following operating conditions.<br><ul style="list-style-type: none"> <li>• Surrounding air temperature: Annual average of 30°C</li> <li>• Load factor: 80% max.</li> <li>• Operation rate: 20 hours/day max.</li> </ul> |
| Electrolytic Capacitor                | 10 years                       |   |
| Inrush Current Limiting Circuit Relay | 100,000 power ON operations    | Power ON frequency: Once an hour  |
| Battery                               | 3 years without power supplied | Surrounding temperature without power supplied: 20°C  |
| Built-in Brake Relay*                 | 30,000 operations              | Allowable number of operations: 30 operations per minute max.   |

\* Only SERVOPACKs with built-in Servomotor brake control have a built-in brake relay.

When any standard replacement period is close to expiring, contact your Yaskawa representative. After an examination of the part in question, we will determine whether the part should be replaced.



Important

The parameters of any SERVOPACKs that are sent to Yaskawa for part replacement are reset to the factory settings before they are returned to you. Always keep a record of the parameter settings. And, always confirm that the parameters are properly set before starting operation.



## 15.1.3 Replacing the Battery

If the battery voltage drops to approximately 2.7 V or less, an A.830 alarm (Encoder Battery Alarm) or an A.930 warning (Absolute Encoder Battery Error) will be displayed.

If this alarm or warning is displayed, the battery must be replaced. Refer to the following section for the battery replacement procedure.

 *Battery Replacement Procedure on page 15-3*

### Battery Alarm/Warning Selection

Whether to display an alarm or a warning is determined by the setting of Pn008 = n.□□□X (Low Battery Voltage Alarm/Warning Selection).

| Parameter        | Meaning                     | When Enabled  | Classification |
|------------------|-----------------------------|---------------|----------------|
| Pn008<br>(2008h) | n.□□□0<br>(default setting) | After restart | Setup          |
|                  | n.□□□1                      |               |                |

- Pn008 = n.□□□0  
The ALM (Servo Alarm) signal is output for up to five seconds when the control power supply is turned ON, and then the battery voltage is monitored for four seconds. No alarm will be displayed even if the battery voltage drops below the specified value after these four seconds.
- Pn008 = n.□□□1  
The ALM (Servo Alarm) signal is output for up to five seconds when the control power supply is turned ON, and then the battery voltage is monitored continuously.

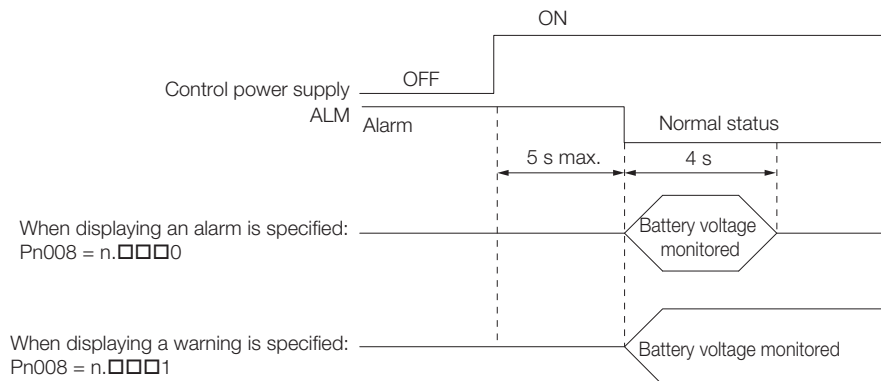

### Battery Replacement Procedure

#### ◆ When Installing a Battery on the Host Controller

1. Turn ON only the control power supply to the SERVOPACK.
2. Remove the old battery and mount a new battery.
3. Turn OFF the control power supply to the SERVOPACK to clear the A.830 alarm (Encoder Battery Alarm).
4. Turn ON the control power supply to the SERVOPACK again.
5. Make sure that the alarm has been cleared and that the SERVOPACK operates normally.

◆ When Using an Encoder Cable with a Battery Case

1. Turn ON only the control power supply to the SERVOPACK.

 If you remove the battery or disconnect the Encoder Cable while the control power supply to the SERVOPACK is OFF, the absolute encoder data will be lost.

Important

2. Open the cover of the Battery Case.

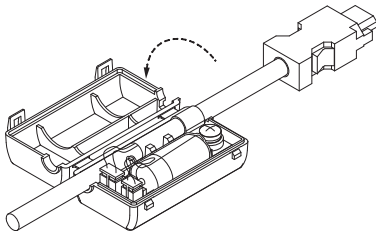

3. Remove the old battery and mount a new battery.

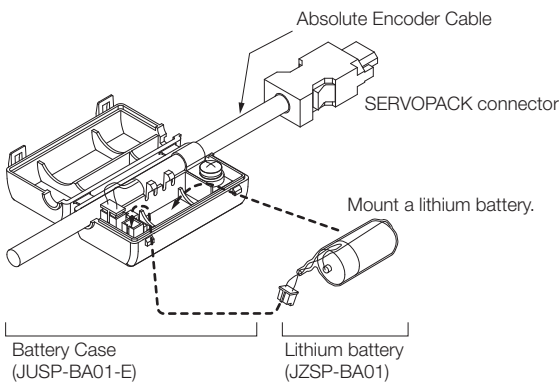

4. Close the cover of the Battery Case.

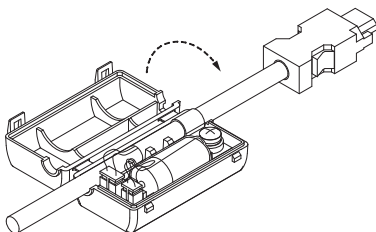

5. Turn OFF the power supply to the SERVOPACK to clear the A.830 alarm (Encoder Battery Alarm).
6. Turn ON the power supply to the SERVOPACK.
7. Make sure that the alarm has been cleared and that the SERVOPACK operates normally.

## 15.2 Alarm Displays

To check an alarm that occurs in the SERVOPACK, use one of the following methods.

However, if no alarm number appears on the panel display, this indicates a SERVOPACK system error. Replace the SERVOPACK.

|                            |   |
|----------------------------|---|
| Panel display on SERVOPACK | <p>If there is an alarm, the code will be displayed one character at a time, as shown below.<br/>Example: Alarm A.020</p> <p>→ Status display → Not lit. → <b>A.</b> → Not lit. → <b>0</b> → Not lit. → <b>2</b> → Not lit. → <b>0</b> → Not lit.</p> |
| Digital Operator           | The alarm code will be displayed.   |
| Status word (6041h)        | Bit 3 ( <i>fault</i> ) in the <i>status word</i> will change to 1. (Bit 3 is 0 during normal operation.)  |
| Error Code (603Fh)         | A current alarm code is stored in object 603Fh.   |
| Emergency message          | The Controller is notified of any alarm that occurs. (Notification may not be possible if EtherCAT communications are unstable.)  |

This section provides a list of the alarms that may occur and the causes of and corrections for those alarms.

### 15.2.1 List of Alarms

The list of alarms gives the alarm name, alarm meaning, alarm stopping method, and alarm reset possibility in order of the alarm numbers.

#### Servomotor Stopping Method for Alarms

Refer to the following section for information on the stopping method for alarms.

6.12.2 Servomotor Stopping Method for Alarms on page 6-37

#### Alarm Reset Possibility

Yes: You can use an alarm reset to clear the alarm. However, this assumes that the cause of the alarm has been removed.

No: You cannot clear the alarm.

#### Alarms for Both Axes

If “Common” is given below the alarm number, the alarm applies to both axes. If an alarm occurs for one axis, the same alarm status will occur for the other axis.

#### List of Alarms

| Alarm Code     | Alarm Name               | Alarm Meaning  | Servo-motor Stopping Method | Alarm Reset Possible? |
|----------------|--------------------------|--|-----------------------------|-----------------------|
| 020h           | Parameter Checksum Error | There is an error in the parameter data in the SERVOPACK.        | Gr.1                        | No                    |
| 021h<br>Common | Parameter Format Error   | There is an error in the parameter data format in the SERVOPACK. | Gr.1                        | No                    |

Continued on next page.

15.2 Alarm Displays

15.2.1 List of Alarms

Continued from previous page.

| Alarm Code     | Alarm Name                             | Alarm Meaning   | Servo-motor Stopping Method | Alarm Reset Possible? |
|----------------|--|---|-----------------------------|-----------------------|
| 022h<br>Common | System Checksum Error                  | There is an error in the parameter data in the SERVOPACK.   | Gr. 1                       | No                    |
| 025h           | System Alarm                           | An internal program error occurred in the SERVOPACK.  | Gr. 1                       | No                    |
| 030h<br>Common | Main Circuit Detector Error            | There is an error in the detection data for the main circuit.   | Gr. 1                       | Yes                   |
| 040h           | Parameter Setting Error                | A parameter setting is outside of the setting range.  | Gr. 1                       | No                    |
| 042h           | Parameter Combination Error            | The combination of some parameters exceeds the setting range.   | Gr. 1                       | No                    |
| 050h           | Combination Error                      | The capacities of the SERVOPACK and Servomotor do not match.  | Gr. 1                       | Yes                   |
| 051h           | Unsupported Device Alarm               | An unsupported device was connected.  | Gr. 1                       | No                    |
| 070h           | Motor Type Change Detected             | The connected motor is a different type of motor from the previously connected motor.   | Gr. 1                       | No                    |
| 080h           | Linear Encoder Pitch Setting Error     | The setting of Pn282 (Linear Encoder Scale Pitch) has not been changed from the default setting.  | Gr. 1                       | No                    |
| 0b0h           | Invalid Servo ON Command Alarm         | The SV_ON (Servo ON) command was sent from the host controller after a utility function that turns ON the Servomotor was executed.  | Gr. 1                       | Yes                   |
| 100h           | Overcurrent Detected                   | An overcurrent flowed through the power transistor or the heat sink overheated.   | Gr. 1                       | No                    |
| 101h           | Motor Overcurrent Detected             | The current to the motor exceeded the allowable current.  | Gr. 1                       | No                    |
| 231h           | Built-in Brake Relay Error Alarm       | The built-in brake relay malfunctioned.   | Gr. 1                       | No                    |
| 232h           | Built-in Brake Relay Life Alarm        | The number of built-in brake relay operations exceeded the service life of the relay.   | Gr. 1                       | No                    |
| 300h<br>Common | Regeneration Error                     | There is an error related to regeneration.  | Gr. 1                       | Yes                   |
| 320h<br>Common | Regenerative Overload                  | A regenerative overload occurred.   | Gr.2                        | Yes                   |
| 330h<br>Common | Main Circuit Power Supply Wiring Error | <ul style="list-style-type: none"> <li>The AC power supply input setting or DC power supply input setting is not correct.</li> <li>The power supply wiring is not correct.</li> </ul> | Gr. 1                       | Yes                   |
| 400h<br>Common | Overvoltage                            | The main circuit DC voltage is too high.  | Gr. 1                       | Yes                   |
| 410h<br>Common | Undervoltage                           | The main circuit DC voltage is too low.   | Gr.2                        | Yes                   |
| 450h<br>Common | Main-Circuit Capacitor Overvoltage     | The capacitor in the main circuit has deteriorated or is faulty.  | Gr. 1                       | No                    |
| 510h           | Overspeed                              | The motor exceeded the maximum speed.   | Gr. 1                       | Yes                   |
| 520h           | Vibration Alarm                        | Abnormal oscillation was detected in the motor speed.   | Gr. 1                       | Yes                   |
| 521h           | Autotuning Alarm                       | Vibration was detected during autotuning for the tuning-less function.  | Gr. 1                       | Yes                   |
| 550h           | Maximum Speed Setting Error            | The setting of Pn385 (Maximum Motor Speed) is greater than the maximum motor speed.   | Gr. 1                       | Yes                   |
| 710h           | Instantaneous Overload                 | The Servomotor was operating for several seconds to several tens of seconds under a torque that largely exceeded the rating.  | Gr.2                        | Yes                   |

Continued on next page.

Continued from previous page.

| Alarm Code                  | Alarm Name   | Alarm Meaning   | Servo-motor Stopping Method | Alarm Reset Possible? |
|-----------------------------|--|---|-----------------------------|-----------------------|
| 720h                        | Continuous Overload  | The Servomotor was operating continuously under a torque that exceeded the rating.  | Gr.1                        | Yes                   |
| 730h<br>731h                | Dynamic Brake Overload   | When the dynamic brake was applied, the rotational or linear kinetic energy exceeded the capacity of the Dynamic Brake Resistor.            | Gr.1                        | Yes                   |
| 740h<br><span>Common</span> | Inrush Current Limiting Resistor Overload                            | The main circuit power supply was frequently turned ON and OFF.   | Gr.1                        | Yes                   |
| 7A1h<br><span>Common</span> | Internal Temperature Error 1 (Control Board Temperature Error)       | The surrounding temperature of the control PCB is abnormal.   | Gr.2                        | Yes                   |
| 7A2h<br><span>Common</span> | Internal Temperature Error 2 (Power Board Temperature Error)         | The surrounding temperature of the power PCB is abnormal.   | Gr.2                        | Yes                   |
| 7A3h                        | Internal Temperature Sensor Error                                    | An error occurred in the temperature sensor circuit.  | Gr.2                        | No                    |
| 7A4h                        | Power Transistor Overheated (Abnormal power transistor temperature.) | The temperature of the power transistor is abnormal.  | Gr.2                        | No                    |
| 7Abh<br><span>Common</span> | SERVOPACK Built-in Fan Stopped                                       | The fan inside the SERVOPACK stopped.   | Gr.1                        | Yes                   |
| 810h                        | Encoder Backup Alarm   | The power supplies to the encoder all failed and the position data was lost.  | Gr.1                        | No                    |
| 820h                        | Encoder Checksum Alarm   | There is an error in the checksum results for encoder memory.   | Gr.1                        | No                    |
| 830h                        | Encoder Battery Alarm  | The battery voltage was lower than the specified level after the control power supply was turned ON.  | Gr.1                        | Yes                   |
| 840h                        | Encoder Data Alarm   | There is an internal data error in the encoder.   | Gr.1                        | No                    |
| 850h                        | Encoder Overspeed  | The encoder was operating at high speed when the power was turned ON.   | Gr.1                        | No                    |
| 860h                        | Encoder Overheated   | The internal temperature of encoder is too high.  | Gr.1                        | No                    |
| 861h                        | Motor Overheated   | The internal temperature of motor is too high.  | Gr.1                        | No                    |
| 862h                        | Overheat Alarm   | The input voltage (temperature) for the overheat protection input (TH) signal exceeded the setting of Pn61B (261Bh) (Overheat Alarm Level). | Gr.1                        | Yes                   |
| 890h                        | Encoder Scale Error  | A failure occurred in the linear encoder.   | Gr.1                        | No                    |
| 891h                        | Encoder Module Error   | An error occurred in the linear encoder.  | Gr.1                        | No                    |
| A10h                        | EtherCAT DC Synchronization Error* <sup>1</sup>                      | The SERVOPACK and Sync0 events cannot be synchronized.  | Gr.2                        | Yes                   |
| A11h                        | EtherCAT State Error   | The EtherCAT AL does not move to the Operational state when the DS402 drive is in Operation Enabled state.                                  | Gr.2                        | Yes                   |
| A12h                        | EtherCAT Outputs Data Synchronization Error* <sup>1</sup>            | The process data reception events and Sync0 events cannot be synchronized. (Process data communications failed.)                            | Gr.2                        | Yes                   |
| A20h                        | Parameter Setting Error  | A parameter setting exceeds the setting range.  | Gr.1                        | No                    |
| A40h                        | System Initialization Error  | Initialization failed when the power supply was turned ON.  | Gr.1                        | No                    |
| A41h                        | Communication Device Initialization Error                            | An error occurred during ESC initialization.  | Gr.1                        | No                    |
| A47h                        | Loading Servo Information Error                                      | Loading SERVOPACK information failed.   | Gr.1                        | No                    |

Continued on next page.

15.2 Alarm Displays

15.2.1 List of Alarms

Continued from previous page.

| Alarm Code     | Alarm Name   | Alarm Meaning  | Servo-motor Stopping Method | Alarm Reset Possible? |
|----------------|--|--|-----------------------------|-----------------------|
| A48h           | EEPROM Parameter Data Error                                  | A checksum error occurred in the EEPROM.   | Gr.1                        | No                    |
| A53h           | Axis detect error  | Object F050h and object F030h do not match.                                      | Gr.2                        | No                    |
| b33h           | Current Detection Error 3                                    | An error occurred in the current detection circuit.                              | Gr.1                        | No                    |
| bC0h<br>Common | System Alarm 10  | Internal program error 10 occurred in the SERVOPACK.                             | Gr.1                        | No                    |
| bF0h<br>Common | System Alarm 0   | Internal program error 0 occurred in the SERVOPACK.                              | Gr.1                        | No                    |
| bF1h<br>Common | System Alarm 1   | Internal program error 1 occurred in the SERVOPACK.                              | Gr.1                        | No                    |
| bF2h<br>Common | System Alarm 2   | Internal program error 2 occurred in the SERVOPACK.                              | Gr.1                        | No                    |
| bF3h<br>Common | System Alarm 3   | Internal program error 3 occurred in the SERVOPACK.                              | Gr.1                        | No                    |
| bF4h<br>Common | System Alarm 4   | Internal program error 4 occurred in the SERVOPACK.                              | Gr.1                        | No                    |
| bF5h<br>Common | System Alarm 5   | Internal program error 5 occurred in the SERVOPACK.                              | Gr.1                        | No                    |
| bF6h<br>Common | System Alarm 6   | Internal program error 6 occurred in the SERVOPACK.                              | Gr.1                        | No                    |
| bF7h<br>Common | System Alarm 7   | Internal program error 7 occurred in the SERVOPACK.                              | Gr.1                        | No                    |
| bF8h<br>Common | System Alarm 8   | Internal program error 8 occurred in the SERVOPACK.                              | Gr.1                        | No                    |
| C10h           | Servomotor Out of Control                                    | The Servomotor ran out of control.   | Gr.1                        | Yes                   |
| C20h           | Phase Detection Error  | The detection of the phase is not correct.                                       | Gr.1                        | No                    |
| C21h           | Polarity Sensor Error  | An error occurred in the polarity sensor.  | Gr.1                        | No                    |
| C22h           | Phase Information Disagreement                               | The phase information does not match.  | Gr.1                        | No                    |
| C50h           | Polarity Detection Failure                                   | The polarity detection failed.   | Gr.1                        | No                    |
| C51h           | Overtravel Detected during Polarity Detection                | The overtravel signal was detected during polarity detection.                    | Gr.1                        | Yes                   |
| C52h           | Polarity Detection Not Completed                             | The servo was turned ON before the polarity was detected.                        | Gr.1                        | Yes                   |
| C53h           | Out of Range of Motion for Polarity Detection                | The travel distance exceeded the setting of Pn48E (Polarity Detection Range).    | Gr.1                        | No                    |
| C54h           | Polarity Detection Failure 2                                 | The polarity detection failed.   | Gr.1                        | No                    |
| C80h           | Encoder Clear Error or Multiturn Limit Setting Error         | The multiturn data for the absolute encoder was not correctly cleared or set.    | Gr.1                        | No                    |
| C90h           | Encoder Communications Error                                 | Communications between the encoder and SERVOPACK is not possible.                | Gr.1                        | No                    |
| C91h           | Encoder Communications Position Data Acceleration Rate Error | An error occurred in calculating the position data of the encoder.               | Gr.1                        | No                    |
| C92h           | Encoder Communications Timer Error                           | An error occurred in the communications timer between the encoder and SERVOPACK. | Gr.1                        | No                    |
| CA0h           | Encoder Parameter Error                                      | The parameters in the encoder are corrupted.                                     | Gr.1                        | No                    |
| Cb0h           | Encoder Echoback Error                                       | The contents of communications with the encoder are incorrect.                   | Gr.1                        | No                    |

Continued on next page.

Continued from previous page.

| Alarm Code         | Alarm Name  | Alarm Meaning  | Servo-motor Stopping Method | Alarm Reset Possible? |
|--------------------|---|--|-----------------------------|-----------------------|
| CC0h               | Multiturn Limit Disagreement                                    | Different multiturn limits have been set in the encoder and the SERVOPACK.   | Gr.1                        | No                    |
| CF1h* <sup>2</sup> | Reception Failed Error in Feedback Option Module Communications | Receiving data from the Feedback Option Module failed.   | Gr.1                        | No                    |
| CF2h* <sup>2</sup> | Timer Stopped Error in Feedback Option Module Communications    | An error occurred in the timer for communications with the Feedback Option Module.   | Gr.1                        | No                    |
| d00h               | Position Deviation Overflow                                     | The setting of Pn520 (2520h) (Position Deviation Alarm Level) was exceeded by the position deviation.  | Gr.1                        | Yes                   |
| d01h               | Position Deviation Overflow Alarm at Servo ON                   | The servo was turned ON after the position deviation exceeded the setting of Pn526 (Position Deviation Overflow Alarm Level at Servo ON) while the servo was OFF.  | Gr.1                        | Yes                   |
| d02h               | Position Deviation Overflow Alarm for Speed Limit at Servo ON   | If position deviation remains in the deviation counter, the setting of Pn529 or Pn584 (Speed Limit Level at Servo ON) limits the speed when the servo is turned ON. This alarm occurs if a position reference is input and the setting of Pn520 (Position Deviation Overflow Alarm Level) is exceeded before the limit is cleared. | Gr.2                        | Yes                   |
| d10h* <sup>2</sup> | Motor-Load Position Deviation Overflow                          | There was too much position deviation between the motor and load during fully-closed loop control.   | Gr.2                        | Yes                   |
| d30h               | Position Data Overflow  | The position feedback data exceeded $\pm 1,879,048,192$ .  | Gr.1                        | No                    |
| E00h               | EtherCAT Module Interface Initialization Timeout Error          | Communications initialization failed between the SERVOPACK and the EtherCAT Module.  | Gr.2                        | Yes                   |
| E02h<br>Common     | MECHATROLINK Internal Synchronization Error 1                   | A synchronization error occurred during MECHATROLINK communications with the SERVOPACK.  | Gr.1                        | Yes                   |
| E03h               | EtherCAT Module Interface Communications Data Error             | There is an error in the communications data between the SERVOPACK and the EtherCAT Module.  | Gr.1                        | Yes                   |
| EA0h               | Command-Option IF Servo Unit Initial Error                      | Communications could not be initialized between the SERVOPACK and EtherCAT (CoE) Network Module within 10 seconds.   | Gr.1                        | No                    |
| EA1h               | Command-Option IF Memory Check Error                            | An error occurred in communications memory between the SERVOPACK and EtherCAT (CoE) Network Module.  | Gr.1                        | No                    |
| EA2h               | Command-Option IF Servo Synchronization Error* <sup>1</sup>     | Communications could not be synchronized between the SERVOPACK and EtherCAT (CoE) Network Module.  | Gr.1                        | Yes                   |
| EA3h               | Command-Option IF Servo Data Error* <sup>1</sup>                | An error occurred in communications data between the SERVOPACK and EtherCAT (CoE) Network Module.  | Gr.1                        | Yes                   |
| Eb1h               | Safety Function Signal Input Timing Error                       | An error occurred in the input timing of the safety function signal.   | Gr.1                        | No                    |
| EC8h               | Gate Drive Error 1  | An error occurred in the gate drive circuit.   | Gr.1                        | No                    |
| EC9h               | Gate Drive Error 2  | An error occurred in the gate drive circuit.   | Gr.1                        | No                    |
| F10h<br>Common     | Power Supply Line Open Phase                                    | The voltage was low for more than one second for phase R, S, or T when the main power supply was ON.   | Gr.2                        | Yes                   |

Continued on next page.

15.2 Alarm Displays

15.2.1 List of Alarms

Continued from previous page.

| Alarm Code                   | Alarm Name                              | Alarm Meaning   | Servo-motor Stopping Method | Alarm Reset Possible? |
|------------------------------|---|---|-----------------------------|-----------------------|
| FL-1* <sup>3</sup><br>Common | System Alarm                            | An internal program error occurred in the SERVOPACK.  | -                           | No                    |
| FL-2* <sup>3</sup><br>Common |   |   |                             |                       |
| FL-3* <sup>3</sup><br>Common |   |   |                             |                       |
| FL-4* <sup>3</sup><br>Common |   |   |                             |                       |
| FL-5* <sup>3</sup><br>Common |   |   |                             |                       |
| FL-6* <sup>3</sup><br>Common |   |   |                             |                       |
| FL-7* <sup>3</sup><br>Common |   |   |                             |                       |
| CPF00<br>Common              | Digital Operator Communications Error 1 | Communications were not possible between the Digital Operator (model: JUSP-OP05A-1-E) and the SERVOPACK (e.g., a CPU error occurred). | -                           | No                    |
| CPF01<br>Common              | Digital Operator Communications Error 2 |   |                             |                       |

\*1. The EtherCAT communications state moved to SAFEOP after an alarm was detected.

\*2. This alarm can occur when a Fully-closed Option Module is mounted.

\*3. These alarms are not stored in the alarm history. They are only displayed on the panel display.



## 15.2.2 Troubleshooting Alarms

The causes of and corrections for the alarms are given in the following table. Contact your Yaskawa representative if you cannot solve a problem with the correction given in the table.

| Alarm Code:<br>Alarm Name   | Possible Cause   | Confirmation   | Correction  | Reference |
|---|--|--|---|-----------|
| 020h:<br>Parameter<br>Checksum Error<br>(There is an error<br>in the parameter<br>data in the SER-<br>VOPACK.)      | The power supply<br>voltage suddenly<br>dropped.   | Measure the power<br>supply voltage.   | Set the power supply volt-<br>age within the specified<br>range, and initialize the<br>parameter settings.  | page 6-9  |
|   | The power supply<br>was shut OFF while<br>writing parameter set-<br>tings.   | Check the timing of<br>shutting OFF the power<br>supply.   | Initialize the parameter<br>settings and then set the<br>parameters again.  |           |
|   | The number of times<br>that parameters were<br>written exceeded the<br>limit.  | Check to see if the<br>parameters were fre-<br>quently changed from<br>the host controller.  | The SERVOPACK may be<br>faulty. Replace the SER-<br>VOPACK.<br>Reconsider the method<br>for writing the parame-<br>ters.                                | -         |
|   | A malfunction was<br>caused by noise from<br>the AC power supply,<br>ground, static elec-<br>tricity, or other source.                                   | Turn the power supply<br>to the SERVOPACK<br>OFF and ON again. If<br>the alarm still occurs,<br>noise may be the<br>cause.                                 | Implement countermea-<br>sures against noise.   | page 4-8  |
|   | Gas, water drops, or<br>cutting oil entered the<br>SERVOPACK and<br>caused failure of the<br>internal components.  | Check the installation<br>conditions.  | The SERVOPACK may be<br>faulty. Replace the SER-<br>VOPACK.   | -         |
|   | A failure occurred in<br>the SERVOPACK.  | Turn the power supply<br>to the SERVOPACK<br>OFF and ON again. If<br>the alarm still occurs,<br>the SERVOPACK may<br>have failed.                          | The SERVOPACK may be<br>faulty. Replace the SER-<br>VOPACK.   | -         |
| 021h:<br>Parameter For-<br>mat Error<br>(There is an error<br>in the parameter<br>data format in the<br>SERVOPACK.) | The software version<br>of the SERVOPACK<br>that caused the alarm<br>is older than the soft-<br>ware version of the<br>parameters specified<br>to write. | Read the product infor-<br>mation to see if the soft-<br>ware versions are the<br>same. If they are differ-<br>ent, it could be the<br>cause of the alarm. | Write the parameters from<br>another SERVOPACK with<br>the same model and the<br>same software version,<br>and then turn the power<br>OFF and ON again. | page 10-2 |
|   | A failure occurred in<br>the SERVOPACK.  | -  | The SERVOPACK may be<br>faulty. Replace the SER-<br>VOPACK.   | -         |
| 022h:<br>System Check-<br>sum Error<br>(There is an error<br>in the parameter<br>data in the SER-<br>VOPACK.)       | The power supply<br>voltage suddenly<br>dropped.   | Measure the power<br>supply voltage.   | The SERVOPACK may be<br>faulty. Replace the SER-<br>VOPACK.   | -         |
|   | The power supply<br>was shut OFF while<br>setting a utility func-<br>tion.   | Check the timing of<br>shutting OFF the power<br>supply.   | The SERVOPACK may be<br>faulty. Replace the SER-<br>VOPACK.   | -         |
|   | A failure occurred in<br>the SERVOPACK.  | Turn the power supply<br>to the SERVOPACK<br>OFF and ON again. If<br>the alarm still occurs,<br>the SERVOPACK may<br>have failed.                          | The SERVOPACK may be<br>faulty. Replace the SER-<br>VOPACK.   | -         |

Continued on next page.

15.2 Alarm Displays

15.2.2 Troubleshooting Alarms

Continued from previous page.

| Alarm Code:<br>Alarm Name   | Possible Cause  | Confirmation  | Correction  | Reference             |
|---|---|---|---|-----------------------|
| <b>024h:</b><br>System Alarm<br>(An internal program error occurred in the SERVOPACK.)            | A failure occurred in the SERVOPACK.  | –   | The SERVOPACK may be faulty. Replace the SERVOPACK.                 | –                     |
| <b>025h:</b><br>System Alarm<br>(An internal program error occurred in the SERVOPACK.)            | A failure occurred in the SERVOPACK.  | –   | The SERVOPACK may be faulty. Replace the SERVOPACK.                 | –                     |
| <b>030h:</b><br>Main Circuit<br>Detector Error  | A failure occurred in the SERVOPACK.  | –   | The SERVOPACK may be faulty. Replace the SERVOPACK.                 | –                     |
|   | The jumper between the DC Reactor terminals (⊖1 and ⊖2) was removed or there is faulty contact.   | –   | Correct the wiring between the DC Reactor terminals.                | –                     |
|   | The cable between the DC Reactor and SERVOPACK is not wired correctly or there is a faulty contact.   |   |   |                       |
| <b>040h:</b><br>Parameter Setting Error<br>(A parameter setting is outside of the setting range.) | The SERVOPACK and Servomotor capacities do not match each other.  | Check the combination of the SERVOPACK and Servomotor capacities.   | Select a proper combination of SERVOPACK and Servomotor capacities. | page 1-13             |
|   | A failure occurred in the SERVOPACK.  | –   | The SERVOPACK may be faulty. Replace the SERVOPACK.                 | –                     |
|   | A parameter setting is outside of the setting range.  | Check the setting ranges of the parameters that have been changed.  | Set the parameters to values within the setting ranges.             | –                     |
|   | A pin number that does not exist on the SERVOPACK was allocated in Pn590 (2590h) to Pn5BC (25BCh). (An alarm will not occur, however, if the signal is disabled.) | For input signals (Pn590 to Pn599), make sure that the allocated pin numbers are between 003 and 014.<br>For output signals (Pn5B0 to Pn5BC), make sure that the allocated pin numbers are between 023 and 031. | Allocate pins that actually exist in Pn590 to Pn5BC.                | page 7-6,<br>page 7-9 |

Continued on next page.

Continued from previous page.

| Alarm Code:<br>Alarm Name  | Possible Cause   | Confirmation   | Correction  | Reference |
|--|--|--|---|-----------|
| 042h:<br>Parameter Com-<br>bination Error  | The speed of program jogging went below the setting range when Pn533 (2533h) or Pn585 (2585h) (Program Jogging Speed) was changed.   | Check to see if the detection conditions* <sup>1</sup> are satisfied.  | Increase the setting of Pn533 (2533h) or Pn585 (2585h).   | page 8-13 |
|  | The combination of Pn001 = n.□□□X (Motor Stopping Method for Servo OFF and Group 1 Alarms), Pn601 (Dynamic Brake Resistor Allowable Energy Consumption), and Pn604 (Dynamic Brake Resistance) is wrong, or the settings of those parameters are wrong. | Check Pn001 = n.□□□X, Pn601, and Pn604.  | <ul style="list-style-type: none"> <li>■ When Not Using an External Dynamic Brake <ul style="list-style-type: none"> <li>• Set Pn001 = n.□□□X to 2 (Coast the motor to a stop without the dynamic brake).</li> <li>• Set Pn601 and Pn604 to 0.</li> </ul> </li> <li>■ When Using an External Dynamic Brake <ul style="list-style-type: none"> <li>• Set Pn001 = n.□□□X to 0 (Stop the motor by applying the dynamic brake) or 1 (Stop the motor by applying the dynamic brake and then release the dynamic brake).</li> <li>• Set Pn601 and Pn604 according to the specifications of the resistor.</li> </ul> </li> </ul> | page 5-9  |
| 050h:<br>Combination Error<br>(The capacities of the SERVOPACK and Servomotor do not match.) | The SERVOPACK and Servomotor capacities do not match each other.   | Confirm that the following condition is met:<br>$1/4 \leq (\text{Servomotor capacity}/\text{SERVOPACK capacity}) \leq 4$ | Select a proper combination of the SERVOPACK and Servomotor capacities.   | page 1-13 |
|  | A failure occurred in the encoder.   | Replace the encoder and check to see if the alarm still occurs.  | Replace the Servomotor or encoder.  | –         |
|  | A failure occurred in the SERVOPACK.   | –  | The SERVOPACK may be faulty. Replace the SERVOPACK.   | –         |
| 051h:<br>Unsupported Device Alarm  | The motor parameter file was not written to the linear encoder. (This applies only when not using a Serial Converter Unit.)  | Check to see if the motor parameter file was written to the linear encoder.  | Write the motor parameter file to the linear encoder.   | page 6-15 |
|  | An unsupported Serial Converter Unit or encoder (e.g., an external encoder) is connected to the SERVOPACK.   | Check the product combination specifications.  | Change to a correct combination of models.  | –         |

Continued on next page.

Continued from previous page.

| Alarm Code:<br>Alarm Name   | Possible Cause  | Confirmation                        | Correction  | Reference  |
|---|---|-------------------------------------|---|------------|
| <b>070h:</b><br>Motor Type Change Detected<br>(The connected motor is a different type of motor from the previously connected motor.) | A Rotary Servomotor was removed and a Linear Servomotor was connected.  | –                                   | Set the parameters for a Linear Servomotor and reset the motor type alarm. Then, turn the power supply to the SERVOPACK OFF and ON again. | page 15-44 |
|   | A Linear Servomotor was removed and a Rotary Servomotor was connected.  | –                                   | Set the parameters for a Rotary Servomotor and reset the motor type alarm. Then, turn the power supply to the SERVOPACK OFF and ON again. | page 15-44 |
| <b>080h:</b><br>Linear Encoder Pitch Setting Error  | The setting of Pn282 (2282h) (Linear Encoder Pitch) has not been changed from the default setting.  | Check the setting of Pn282 (2282h). | Correct the setting of Pn282 (2282h).   | page 6-14  |
| <b>0b0h:</b><br>Invalid Servo ON Command Alarm  | The Servo ON command (Enable Operation command) was sent from the host controller after a utility function that turns ON the Servomotor was executed. | –                                   | Turn the power supply to the SERVOPACK OFF and ON again. Or, execute a software reset.  | page 7-35  |

Continued on next page.

Continued from previous page.

| Alarm Code:<br>Alarm Name  | Possible Cause  | Confirmation   | Correction   | Reference |
|--|---|--|--|-----------|
| 100h:<br>Overcurrent<br>Detected<br>(An overcurrent<br>flowed through<br>the power trans-<br>former or the heat<br>sink overheated.) | The Main Circuit Cable is not wired correctly or there is faulty contact.   | Check the wiring.  | Correct the wiring.  | page 4-19 |
|  | There is a short-circuit or ground fault in a Main Circuit Cable.   | Check for short-circuits across Servomotor phases U, V, and W, or between the ground and Servomotor phases U, V, and W.  | The cable may be short-circuited. Replace the cable.   |           |
|  | There is a short-circuit or ground fault inside the Servomotor.   | Check for short-circuits across Servomotor phases U, V, and W, or between the ground and Servomotor phases U, V, or W.   | The Servomotor may be faulty. Replace the Servomotor.  |           |
|  | There is a short-circuit or ground fault inside the SERVOPACK.  | Check for short-circuits across the Servomotor connection terminals U, V, and W on the SERVOPACK, or between the ground and terminals U, V, or W.                                | The SERVOPACK may be faulty. Replace the SERVOPACK.  |           |
|  | The Regenerative Resistor is not wired correctly or there is faulty contact.  | Check the wiring.  | Correct the wiring.  | page 4-18 |
|  | The dynamic brake (DB, emergency stop executed from the SERVOPACK) was frequently activated, or a DB overload alarm occurred. | Check the power consumed by the DB resistor to see how frequently the DB is being used. Or, check the alarm display to see if a DB overload alarm (A.730 or A.731) has occurred. | Change the SERVOPACK model, operating methods, or the mechanisms so that the dynamic brake does not need to be used so frequently. | -         |
|  | The regenerative processing capacity was exceeded.  | Check the regenerative load ratio in the SigmaWin+ Motion Monitor Tab Page to see how frequently the Regenerative Resistor is being used.  | Recheck the operating conditions and load.   | *2        |
|  | The SERVOPACK regenerative resistance is too small.   | Check the regenerative load ratio in the SigmaWin+ Motion Monitor Tab Page to see how frequently the Regenerative Resistor is being used.  | Change the regenerative resistance to a value larger than the SERVOPACK minimum allowable resistance.                              | -         |
| A heavy load was applied while the Servomotor was stopped or running at a low speed.   | Check to see if the operating conditions exceed Servo Drive specifications.   | Reduce the load applied to the Servomotor. Or, increase the operating speed.   | -  |           |

Continued on next page.

Continued from previous page.

| Alarm Code:<br>Alarm Name  | Possible Cause   | Confirmation  | Correction   | Reference |
|--|--|---|--|-----------|
| <b>100h:</b><br>Overcurrent Detected<br>(An overcurrent flowed through the power transformer or the heat sink overheated.) | A malfunction was caused by noise.   | Improve the noise environment, e.g. by improving the wiring or installation conditions, and check to see if the alarm still occurs.               | Implement countermeasures against noise, such as correct wiring of the FG. Use an FG wire size equivalent to the SERVOPACK's main circuit wire size. | -         |
|  | A failure occurred in the SERVOPACK.   | -   | Turn the power supply to the SERVOPACK OFF and ON again. If an alarm still occurs, the SERVOPACK may be faulty. Replace the SERVOPACK.               | -         |
| <b>101h:</b><br>Motor Overcurrent Detected<br>(The current to the motor exceeded the allowable current.)                   | The Main Circuit Cable is not wired correctly or there is faulty contact.            | Check the wiring.   | Correct the wiring.  | page 4-19 |
|  | There is a short-circuit or ground fault in a Main Circuit Cable.                    | Check for short-circuits across cable phases U, V, and W, or between the ground and cable phases U, V, and W.                                     | The cable may be short-circuited. Replace the cable.   |           |
|  | There is a short-circuit or ground fault inside the Servomotor.                      | Check for short-circuits across Servomotor phases U, V, and W, or between the ground and Servomotor phases U, V, or W.                            | The Servomotor may be faulty. Replace the Servomotor.  |           |
|  | There is a short-circuit or ground fault inside the SERVOPACK.                       | Check for short-circuits across the Servomotor connection terminals U, V, and W on the SERVOPACK, or between the ground and terminals U, V, or W. | The SERVOPACK may be faulty. Replace the SERVOPACK.  |           |
|  | A heavy load was applied while the Servomotor was stopped or running at a low speed. | Check to see if the operating conditions exceed Servo Drive specifications.   | Reduce the load applied to the Servomotor. Or, increase the operating speed.   | -         |
|  | A malfunction was caused by noise.   | Improve the noise environment, e.g. by improving the wiring or installation conditions, and check to see if the alarm still occurs.               | Implement countermeasures against noise, such as correct wiring of the FG. Use an FG wire size equivalent to the SERVOPACK's main circuit wire size. | -         |
|  | A failure occurred in the SERVOPACK.   | -   | Turn the power supply to the SERVOPACK OFF and ON again. If an alarm still occurs, the SERVOPACK may be faulty. Replace the SERVOPACK.               | -         |

Continued on next page.

Continued from previous page.

| Alarm Code:<br>Alarm Name                    | Possible Cause   | Confirmation  | Correction   | Reference |
|--|--|---|--|-----------|
| 231h:<br>Built-in Brake<br>Relay Error Alarm | A malfunction was caused by noise.   | Turn the power supply to the SERVOPACK OFF and ON again. If the alarm still occurs, noise may be the cause.   | Implement countermeasures against noise.   | –         |
|  | The built-in brake relay failed.   | –   | Replace the part. Contact your Yaskawa representative for replacement.   | –         |
|  | The brake power supply wiring is wrong, disconnected, or broken.   | Check the brake power supply wiring.  | Wire the brake power supply correctly.   | –         |
| 232h:<br>Built-in Brake<br>Relay Life Alarm  | The service life of the built-in brake relay was exceeded.   | –   | Replace the part. Contact your Yaskawa representative for replacement.   | –         |
| 300h:<br>Regeneration<br>Error               | The jumper between the Regenerative Resistor terminals (B2 and B3) was removed.  | Check to see if the jumper is connected between power supply terminals B2 and B3.<br>Note: The SERVOPACK will be damaged if the External Regenerative Resistor is connected while the jumper connected between B2 and B3.     | Correctly connect a jumper.  | page 4-18 |
|  | The External Regenerative Resistor or Regenerative Resistor Unit is not wired correctly, or was removed or disconnected. | Check the wiring of the External Regenerative Resistor or Regenerative Resistor Unit.<br>Note: The SERVOPACK will be damaged if the External Regenerative Resistor is connected while the jumper connected between B2 and B3. | Correct the wiring of the External Regenerative Resistor or Regenerative Resistor Unit.  |           |
|  | A failure occurred in the SERVOPACK.   | –   | While the main circuit power supply is OFF, turn the control power supply to the SERVOPACK OFF and ON again. If an alarm still occurs, the SERVOPACK may be faulty. Replace the SERVOPACK. | –         |

Continued on next page.

Continued from previous page.

| Alarm Code:<br>Alarm Name   | Possible Cause  | Confirmation   | Correction   | Reference |
|---|---|--|--|-----------|
| <b>320h:</b><br>Regenerative<br>Overload  | The power supply voltage exceeded the specified range.  | Measure the power supply voltage.  | Set the power supply voltage within the specified range.   | –         |
|   | The external regenerative resistance value or Regenerative Resistor capacity is too small, or there has been a continuous regeneration state. | Check the operating conditions and capacity again.   | Change the regenerative resistance value or capacity. Recheck the operating conditions.  | *2        |
|   | There was a continuous regeneration state because a negative load was continuously applied.   | Check the load applied to the Servomotor during operation.                                   | Reconsider the system including the servo, machine, and operating conditions.  | –         |
|   | The setting of Pn600 (2600h) (Regenerative Resistor Capacity) is smaller than the capacity of the External Regenerative Resistor.             | Check to see if a Regenerative Resistor is connected and check the setting of Pn600 (2600h). | Correct the setting of Pn600 (2600h).  | page 6-54 |
|   | The setting of Pn603 (2603h) (Regenerative Resistance) is smaller than the capacity of the External Regenerative Resistor.                    | Check to see if a Regenerative Resistor is connected and check the setting of Pn603 (2603h). | Correct the setting of Pn603 (2603h).  | page 6-54 |
|   | The external regenerative resistance is too high.   | Check the regenerative resistance.   | Change the regenerative resistance to a correct value or use an External Regenerative Resistor of an appropriate capacity.   | *2        |
|   | A failure occurred in the SERVOPACK.  | –  | The SERVOPACK may be faulty. Replace the SERVOPACK.  | –         |
| <b>330h:</b><br>Main Circuit<br>Power Supply<br>Wiring Error<br>(Detected when the main circuit power supply is turned ON.) | The Regenerative Resistor was disconnected when the SERVOPACK power supply voltage was high.  | Measure the resistance of the Regenerative Resistor using a measuring instrument.            | If you are using the Regenerative Resistor built into the SERVOPACK, replace the SERVOPACK.<br>If you are using an External Regenerative Resistor, replace the External Regenerative Resistor. | –         |
|   | DC power was supplied when an AC power supply input was specified in the settings.  | Check the power supply to see if it is a DC power supply.                                    | Correct the power supply setting to match the actual power supply.   | page 6-11 |
|   | AC power was supplied when a DC power supply input was specified in the settings.   | Check the power supply to see if it is an AC power supply.                                   | Correct the power supply setting to match the actual power supply.   |           |
|   | A failure occurred in the SERVOPACK.  | –  | The SERVOPACK may be faulty. Replace the SERVOPACK.  | –         |

Continued on next page.



Continued from previous page.

| Alarm Code:<br>Alarm Name   | Possible Cause  | Confirmation   | Correction  | Reference |
|---|---|--|---|-----------|
| 400h:<br>Overvoltage<br>(Detected in the main circuit power supply section of the SERVOPACK.) | The power supply voltage exceeded the specified range.                            | Measure the power supply voltage.  | Set the AC/DC power supply voltage within the specified range.  | –         |
|   | The power supply is not stable or was influenced by a lightning surge.            | Measure the power supply voltage.  | Improve the power supply conditions, install a surge absorber, and then turn the power supply OFF and ON again. If an alarm still occurs, the SERVOPACK may be faulty. Replace the SERVOPACK. | –         |
|   | The voltage for AC power supply was too high during acceleration or deceleration. | Check the power supply voltage and the speed and torque during operation.                | Set the AC power supply voltage within the specified range.   | –         |
|   | The external regenerative resistance is too high for the operating conditions.    | Check the operating conditions and the regenerative resistance.                          | Select a regenerative resistance value that is appropriate for the operating conditions and load.   | *2        |
|   | The moment of inertia ratio or mass ratio exceeded the allowable value.           | Check to see if the moment of inertia ratio or mass ratio is within the allowable range. | Increase the deceleration time, or reduce the load.   | –         |
|   | A failure occurred in the SERVOPACK.  | –  | While the main circuit power supply is OFF, turn the control power supply to the SERVOPACK OFF and ON again. If an alarm still occurs, the SERVOPACK may be faulty. Replace the SERVOPACK.    | –         |

Continued on next page.

15.2 Alarm Displays

15.2.2 Troubleshooting Alarms

Continued from previous page.

| Alarm Code:<br>Alarm Name   | Possible Cause  | Confirmation                           | Correction   | Reference |
|---|---|--|--|-----------|
| <b>410h:</b><br>Undervoltage<br>(Detected in the main circuit power supply section of the SERVOPACK.)                 | The power supply voltage went below the specified range.  | Measure the power supply voltage.      | Set the power supply voltage within the specified range.   | -         |
|   | The power supply voltage dropped during operation.  | Measure the power supply voltage.      | Increase the power supply capacity.  | -         |
|   | A momentary power interruption occurred.  | Measure the power supply voltage.      | If you have changed the setting of Pn509 (2509h) (Momentary Power Interruption Hold Time), decrease the setting. | page 7-18 |
|   | The SERVOPACK fuse is blown out.  | Check the power supply wiring.         | Correct the power supply wiring and replace the SERVOPACK.   | page 4-15 |
|   | The SERVOPACK fuse is blown out.  | -                                      | Replace the SERVOPACK and connect a Reactor to the DC Reactor terminals (⊖1 and ⊖2) on the SERVOPACK.            | -         |
|   | A failure occurred in the SERVOPACK.  | -                                      | The SERVOPACK may be faulty. Replace the SERVOPACK.  | -         |
|   | The jumper between the DC Reactor terminals (⊖1 and ⊖2) was removed or there is faulty contact. | -                                      | Correct the wiring between the DC Reactor terminals.   | -         |
| The cable between the DC Reactor and SERVOPACK is not wired correctly or there is a faulty contact.                   |   |  |  |           |
| <b>450h:</b><br>Main-Circuit Capacitor Overvoltage (The capacitor in the main circuit has deteriorated or is faulty.) | A failure occurred in the SERVOPACK.  | -                                      | Replace the SERVOPACK.   | -         |
| <b>510h:</b><br>Overspeed<br>(The motor exceeded the maximum speed.)  | The order of phases U, V, and W in the motor wiring is not correct.                             | Check the wiring of the Servomotor.    | Make sure that the Servomotor is correctly wired.  | -         |
|   | A reference value that exceeded the over-speed detection level was input.                       | Check the input reference.             | Reduce the reference value. Or, adjust the gain.   | -         |
|   | The motor exceeded the maximum speed.   | Check the waveform of the motor speed. | Reduce the speed reference input gain and adjust the servo gain. Or, reconsider the operating conditions.        | -         |
|   | A failure occurred in the SERVOPACK.  | -                                      | The SERVOPACK may be faulty. Replace the SERVOPACK.  | -         |

Continued on next page.

Continued from previous page.

| Alarm Code:<br>Alarm Name   | Possible Cause  | Confirmation   | Correction  | Reference               |
|---|---|--|---|-------------------------|
| 520h:<br>Vibration Alarm  | Abnormal oscillation was detected in the motor speed.   | Check for abnormal motor noise, and check the speed and torque waveforms during operation.   | Reduce the motor speed. Or, reduce the setting of Pn100 (2100h) (Speed Loop Gain).  | page 9-77               |
|   | The setting of Pn103 (2103h) (Moment of Inertia Ratio) is greater than the actual moment of inertia or was greatly changed. | Check the moment of inertia ratio or mass ratio.   | Correct the setting of Pn103 (2103h).   | page 9-16               |
|   | The vibration detection level (Pn312 or Pn384) is not suitable.   | Check that the vibration detection level (Pn312 or Pn384) is suitable.   | Set a suitable vibration detection level (Pn312 or Pn384).  | page 7-37               |
| 521h:<br>Autotuning Alarm<br>(Vibration was detected while executing the custom tuning, Easy FFT, or the tuning-less function.) | The Servomotor vibrated considerably while performing the tuning-less function.   | Check the waveform of the motor speed.   | Reduce the load so that the moment of inertia ratio is within the allowable value. Or increase the load level or reduce the rigidity level in the tuning-less level settings. | page 9-12               |
|   | The Servomotor vibrated considerably while performing custom tuning or Easy FFT.  | Check the waveform of the motor speed.   | Check the operating procedure of corresponding function and implement corrections.  | page 9-42,<br>page 9-93 |
| 550h:<br>Maximum Speed Setting Error  | The setting of Pn385 (2385h) (Maximum Motor Speed) is greater than the maximum speed.                                       | Check the setting of Pn385 (2385h), and the upper limits of the maximum motor speed setting and the encoder output resolution setting. | Set Pn385 (2385h) to a value that does not exceed the maximum motor speed.  | page 7-21               |

Continued on next page.

15.2 Alarm Displays

15.2.2 Troubleshooting Alarms

Continued from previous page.

| Alarm Code:<br>Alarm Name   | Possible Cause   | Confirmation  | Correction  | Reference |
|---|--|---|---|-----------|
| 710h:<br>Instantaneous<br>Overload<br>720h:<br>Continuous<br>Overload   | The wiring is not correct or there is a faulty connection in the motor or encoder wiring.  | Check the wiring.   | Make sure that the Servomotor and encoder are correctly wired.  | page 4-19 |
|   | Operation was performed that exceeded the overload protection characteristics.   | Check the motor overload characteristics and Run command.   | Reconsider the load and operating conditions. Or, increase the motor capacity.  | -         |
|   | An excessive load was applied during operation because the Servomotor was not driven due to mechanical problems.                                     | Check the operation reference and motor speed.  | Correct the mechanical problem.   | -         |
|   | Operation was performed with a load applied to the shaft of the servomotor that exceeded the allowable value.  | Check the condition of the machine to determine if a load was applied to the shaft of the servomotor that exceeded the allowable value. | Correct the condition of the machine so that the load on the shaft during servomotor operation does not exceed the allowable value.   | -         |
|   | There is an error in the setting of Pn282 (2282h) (Linear Encoder Scale Pitch).  | Check the setting of Pn282 (2282h).   | Correct the setting of Pn282 (2282h).   | page 6-14 |
|   | There is an error in the setting of Pn080 (2080h) = n.□□X□ (Motor Phase Sequence Selection).   | Check the setting of Pn080 (2080h) = n.□□X□.  | Set Pn080 (2080h) = n.□□X□ to an appropriate value.   | page 6-19 |
|   | A failure occurred in the SERVOPACK.   | -   | The SERVOPACK may be faulty. Replace the SERVOPACK.   | -         |
| 730h and<br>731h:<br>Dynamic Brake<br>Overload<br>(An excessive power consumption by the dynamic brake was detected.)         | The Servomotor was rotated by an external force.   | Check the operation status.   | Implement measures to ensure that the motor will not be rotated by an external force.   | -         |
|   | When the Servomotor was stopped with the dynamic brake, the rotational or linear kinetic energy exceeded the capacity of the Dynamic Brake Resistor. | Check the power consumed by the DB resistor to see how frequently the DB is being used.   | Reconsider the following: <ul style="list-style-type: none"> <li>• Reduce the Servomotor command speed.</li> <li>• Decrease the moment of inertia ratio or mass ratio.</li> <li>• Reduce the frequency of stopping with the dynamic brake.</li> </ul> | -         |
|   | A failure occurred in the SERVOPACK.   | -   | The SERVOPACK may be faulty. Replace the SERVOPACK.   | -         |
| 740h:<br>Inrush Current<br>Limiting Resistor<br>Overload<br>(The main circuit power supply was frequently turned ON and OFF.) | The allowable frequency of the inrush current limiting resistor was exceeded when the main circuit power supply was turned ON and OFF.               | -   | Reduce the frequency of turning the main circuit power supply ON and OFF.   | -         |
|   | A failure occurred in the SERVOPACK.   | -   | The SERVOPACK may be faulty. Replace the SERVOPACK.   | -         |

Continued on next page.

Continued from previous page.

| Alarm Code:<br>Alarm Name  | Possible Cause   | Confirmation  | Correction   | Reference             |
|--|--|---|--|-----------------------|
| 7A1h:<br>Internal Temperature Error 1<br>(Control Board Temperature Error)                           | The surrounding temperature is too high.   | Check the surrounding temperature using a thermometer. Or, check the operating status with the SERVOPACK installation environment monitor.            | Decrease the surrounding temperature by improving the SERVOPACK installation conditions. | page 3-6              |
|  | An overload alarm was reset by turning OFF the power supply too many times.                                | Check the alarm display to see if there is an overload alarm.   | Change the method for resetting the alarm.   | –                     |
|  | There was an excessive load or operation was performed that exceeded the regenerative processing capacity. | Use the accumulated load ratio to check the load during operation, and use the regenerative load ratio to check the regenerative processing capacity. | Reconsider the load and operating conditions.  | –                     |
|  | The SERVOPACK installation orientation is not correct or there is insufficient space around the SERVOPACK. | Check the SERVOPACK installation conditions.  | Install the SERVOPACK according to specifications.                                       | page 3-3,<br>page 3-5 |
|  | A failure occurred in the SERVOPACK.   | –   | The SERVOPACK may be faulty. Replace the SERVOPACK.                                      | –                     |
| 7A2h:<br>Internal Temperature Error 2<br>(Power Board Temperature Error)                             | The surrounding temperature is too high.   | Check the surrounding temperature using a thermometer. Or, check the operating status with the SERVOPACK installation environment monitor.            | Decrease the surrounding temperature by improving the SERVOPACK installation conditions. | page 3-6              |
|  | An overload alarm was reset by turning OFF the power supply too many times.                                | Check the alarm display to see if there is an overload alarm.   | Change the method for resetting the alarm.   | –                     |
|  | There was an excessive load or operation was performed that exceeded the regenerative processing capacity. | Use the accumulated load ratio to check the load during operation, and use the regenerative load ratio to check the regenerative processing capacity. | Reconsider the load and operating conditions.  | –                     |
|  | The SERVOPACK installation orientation is not correct or there is insufficient space around the SERVOPACK. | Check the SERVOPACK installation conditions.  | Install the SERVOPACK according to specifications.                                       | page 3-3,<br>page 3-5 |
|  | A failure occurred in the SERVOPACK.   | –   | The SERVOPACK may be faulty. Replace the SERVOPACK.                                      | –                     |
| 7A3h:<br>Internal Temperature Sensor Error<br>(An error occurred in the temperature sensor circuit.) | A failure occurred in the SERVOPACK.   | –   | The SERVOPACK may be faulty. Replace the SERVOPACK.                                      | –                     |

Continued on next page.

15.2 Alarm Displays

15.2.2 Troubleshooting Alarms

Continued from previous page.

| Alarm Code:<br>Alarm Name   | Possible Cause  | Confirmation  | Correction  | Reference             |
|---|---|---|---|-----------------------|
| <b>7A4h:</b><br>Power Transistor Overheated<br>(Abnormal power transistor temperature.)                       | The surrounding temperature is too high.  | Check the surrounding temperature using a thermostat. Or, check the operating status with the SERVOPACK installation environment monitor.             | Decrease the surrounding temperature by improving the SERVOPACK installation conditions.                                | page 3-6              |
|   | An overload alarm was reset by turning OFF the power supply too many times.   | Check the alarm display to see if there is an overload alarm.   | Change the method for resetting the alarm.  | –                     |
|   | There was an excessive load or operation was performed that exceeded the regenerative processing capacity.                  | Use the accumulated load ratio to check the load during operation, and use the regenerative load ratio to check the regenerative processing capacity. | Reconsider the load and operating conditions.   | –                     |
|   | The SERVOPACK installation orientation is not correct or there is insufficient space around the SERVOPACK.                  | Check the SERVOPACK installation conditions.  | Install the SERVOPACK according to specifications.  | page 3-3,<br>page 3-5 |
|   | A failure occurred in the SERVOPACK.  | –   | The SERVOPACK may be faulty. Replace the SERVOPACK.   | –                     |
| <b>7Abh:</b><br>SERVOPACK Built-in Fan Stopped  | The fan inside the SERVOPACK stopped.   | Check for foreign matter inside the SERVOPACK.  | Remove foreign matter from the SERVOPACK. If an alarm still occurs, the SERVOPACK may be faulty. Replace the SERVOPACK. | –                     |
| <b>810h:</b><br>Encoder Backup Alarm<br>(Detected at the encoder, but only when an absolute encoder is used.) | The power to the absolute encoder was turned ON for the first time.   | Check to see if the power supply was turned ON for the first time.  | Set up the encoder.   | page 6-48             |
|   | The Encoder Cable was disconnected and then connected again.  | Check to see if the power supply was turned ON for the first time.  | Check the encoder connection and set up the encoder.  |                       |
|   | Power is not being supplied both from the control power supply (+5 V) from the SERVOPACK and from the battery power supply. | Check the encoder connector battery and the connector status.   | Replace the battery or implement similar measures to supply power to the encoder, and set up the encoder.               | –                     |
|   | A failure occurred in the absolute encoder.   | –   | If the alarm still occurs after setting up the encoder again, replace the Servomotor.                                   | –                     |
|   | A failure occurred in the SERVOPACK.  | –   | The SERVOPACK may be faulty. Replace the SERVOPACK.   | –                     |

Continued on next page.

Continued from previous page.

| Alarm Code:<br>Alarm Name  | Possible Cause  | Confirmation                             | Correction  | Reference |
|--|---|--|---|-----------|
| 820h:<br>Encoder Checksum Alarm<br>(Detected at the encoder.)  | A failure occurred in the encoder.                              | —  | <ul style="list-style-type: none"> <li>■ When Using an Absolute Encoder<br/>Set up the encoder again. If the alarm still occurs, the Servomotor may be faulty. Replace the Servomotor.</li> <li>■ When Using a Single-turn Absolute Encoder or Incremental Encoder <ul style="list-style-type: none"> <li>• The Servomotor may be faulty. Replace the Servomotor.</li> <li>• The linear encoder may be faulty. Replace the linear encoder.</li> </ul> </li> </ul> | page 6-48 |
|  | A failure occurred in the SERVOPACK.                            | —  | The SERVOPACK may be faulty. Replace the SERVOPACK.   | —         |
| 830h:<br>Encoder Battery Alarm<br>(The absolute encoder battery voltage was lower than the specified level.) | The battery connection is faulty or a battery is not connected. | Check the battery connection.            | Correct the battery connection.   | page 15-3 |
|  | The battery voltage is lower than the specified value (2.7 V).  | Measure the battery voltage.             | Replace the battery.  | page 15-3 |
|  | A failure occurred in the SERVOPACK.                            | —  | The SERVOPACK may be faulty. Replace the SERVOPACK.   | —         |
| 840h:<br>Encoder Data Alarm<br>(Detected at the encoder.)  | The encoder malfunctioned.                                      | —  | Turn the power supply to the SERVOPACK OFF and ON again. If an alarm still occurs, the Servomotor or linear encoder may be faulty. Replace the Servomotor or linear encoder.  | —         |
|  | An error occurred in reading data from the linear encoder.      | —  | The linear encoder is not mounted within an appropriate tolerance. Correct the mounting of the linear encoder.  | —         |
|  | Excessive speed occurred in the linear encoder.                 | —  | Control the motor speed within the range specified by the linear encoder manufacturer and then turn ON the control power supply.  | —         |
|  | The encoder malfunctioned due to noise.                         | —  | Correct the wiring around the encoder by separating the Encoder Cable from the Servomotor Main Circuit Cable or by grounding the encoder.   | —         |
|  | The polarity sensor is not wired correctly.                     | Check the wiring of the polarity sensor. | Correct the wiring of the polarity sensor.  | —         |
|  | The polarity sensor failed.                                     | —  | Replace the polarity sensor.  | —         |

Continued on next page.

Continued from previous page.

| Alarm Code:<br>Alarm Name  | Possible Cause  | Confirmation   | Correction   | Reference |
|--|---|--|--|-----------|
| <b>850h:</b><br>Encoder Over-speed<br>(Detected at the encoder when the control power supply is turned ON.)  | Rotary Servomotor:<br>The Servomotor speed was 200 min <sup>-1</sup> or higher when the control power supply was turned ON. | Check the motor speed when the power supply is turned ON.      | Reduce the Servomotor speed to a value less than 200 min <sup>-1</sup> , and turn ON the control power supply.   | -         |
|  | Linear Servomotor:<br>The Servomotor exceeded the specified speed when the control power supply was turned ON.              | Check the motor speed when the power supply is turned ON.      | Control the motor speed within the range specified by the linear encoder manufacturer and then turn ON the control power supply.   | -         |
|  | A failure occurred in the encoder.  | -  | Turn the power supply to the SERVOPACK OFF and ON again. If an alarm still occurs, the Servomotor or linear encoder may be faulty. Replace the Servomotor or linear encoder.                   | -         |
|  | A failure occurred in the SERVOPACK.  | -  | Turn the power supply to the SERVOPACK OFF and ON again. If an alarm still occurs, the SERVOPACK may be faulty. Replace the SERVOPACK.   | -         |
| <b>860h:</b><br>Encoder Over-heated<br>(Detected at the encoder, but only when an absolute encoder is used.) | The surrounding air temperature around the Servomotor is too high.  | Measure the surrounding air temperature around the Servomotor. | Reduce the surrounding air temperature of the Servomotor to 40°C or less.  | -         |
|  | The Servomotor load is greater than the rated load.   | Use the accumulated load ratio to check the load.              | Operate the Servo Drive so that the motor load remains within the specified range.   | page 10-3 |
|  | A failure occurred in the encoder.  | -  | Turn the power supply to the SERVOPACK OFF and ON again. If an alarm still occurs, the Servomotor or absolute linear encoder may be faulty. Replace the Servomotor or absolute linear encoder. | -         |
|  | A failure occurred in the SERVOPACK.  | -  | Turn the power supply to the SERVOPACK OFF and ON again. If an alarm still occurs, the SERVOPACK may be faulty. Replace the SERVOPACK.   | -         |

Continued on next page.



Continued from previous page.

| Alarm Code:<br>Alarm Name     | Possible Cause  | Confirmation  | Correction  | Reference |
|-------------------------------|---|---|---|-----------|
| 861h:<br>Motor Overheated     | The surrounding temperature around the Servomotor is too high.  | Measure the surrounding temperature around the Servomotor.  | Reduce the surrounding air temperature of the Servomotor to 40°C or less.   | -         |
|                               | The motor load is greater than the rated load.  | Check the load with the accumulated load ratio on the Motion Monitor Tab Page on the SigmaWin+.                         | Operate the Servo Drive so that the motor load remains within the specified range.  | page 10-3 |
|                               | A failure occurred in the Serial Converter Unit.  | -   | Turn the power supply to the SERVOPACK OFF and ON again. If an alarm still occurs, the Serial Converter Unit may be faulty. Replace the Serial Converter Unit.  | -         |
|                               | A failure occurred in the SERVOPACK.  | -   | Turn the power supply to the SERVOPACK OFF and ON again. If an alarm still occurs, the SERVOPACK may be faulty. Replace the SERVOPACK.  | -         |
| 862h:<br>Overheat Alarm       | The surrounding temperature is too high.  | Check the surrounding temperature using a thermometer.  | Lower the surrounding temperature by improving the installation conditions of the Linear Servomotor or the machine.   | -         |
|                               | The overheat protection input signal line is disconnected or short-circuited.   | Check the input voltage with the overheat protection input information on the Motion Monitor Tab Page on the SigmaWin+. | Repair the line for the overheat protection input signal.   | -         |
|                               | An overload alarm was reset by turning OFF the power supply too many times.   | Check the alarm display to see if there is an overload alarm.   | Change the method for resetting the alarm.  | -         |
|                               | Operation was performed under an excessive load.  | Use the accumulated load ratio to check the load during operation.  | Reconsider the load and operating conditions.   | -         |
|                               | A failure occurred in the SERVOPACK.  | -   | The SERVOPACK may be faulty. Replace the SERVOPACK.   | -         |
|                               | The temperature detection circuit in the Linear Servomotor is faulty or the sensor attached to the machine is faulty. | -   | The temperature detection circuit in the Linear Servomotor may be faulty or the sensor attached to the machine may be faulty. Replace the Linear Servomotor or repair the sensor attached to the machine. | -         |
| 890h:<br>Encoder Scale Error  | A failure occurred in the linear encoder.   | -   | The linear encoder may be faulty. Replace the linear encoder.   | -         |
| 891h:<br>Encoder Module Error | A failure occurred in the linear encoder.   | -   | Turn the power supply to the SERVOPACK OFF and ON again. If an alarm still occurs, the linear encoder may be faulty. Replace the linear encoder.  | -         |

Continued on next page.

Continued from previous page.

| Alarm Code:<br>Alarm Name                           | Possible Cause   | Confirmation   | Correction  | Reference |
|---|--|--|---|-----------|
| A10h:<br>EtherCAT DC Synchronization Error          | The synchronization timing (Sync0) for EtherCAT communications fluctuated.           | –  | Turn the power supply OFF and ON again and re-establish communications.             | –         |
| A11h:<br>EtherCAT State Error                       | The EtherCAT communications state left the Operational state during motor operation. | –  | Reset the alarm and then re-establish communications.                               | –         |
| A12h:<br>EtherCAT Output Data Synchronization Error | Noise caused an error in EtherCAT communications.                                    | –  | Check the EtherCAT wiring and implement noise countermeasures.                      | –         |
|   | The controller did not update the process data during the fixed period.              | Check the process data specified by the controller.  | Correct the controller so that the process data is updated during the fixed period. | –         |
|   | The EtherCAT Communications Cable or connector wiring is faulty.                     | Check the EtherCAT Communications Cable and connector wiring.  | Wire the connections correctly.   | –         |
| A20h:<br>Parameter Setting Error                    | The position unit is outside of the setting range.                                   | Make sure it is within the following range.<br>$1/4,096 < \text{Numerator (2701h: 1)}/\text{Denominator (2701h: 2)} < 65,536$        | Correct the setting of <i>position user unit (2701h)</i> .                          | –         |
|   | The speed unit is outside of the setting range.                                      | Make sure it is within the following range.<br>$1/128 \leq \text{Numerator (2702h: 1)}/\text{Denominator (2702h: 2)} \leq 8,388,608$ | Correct the setting of <i>velocity user unit (2702h)</i> .                          | –         |
|   | The acceleration unit is outside of the setting range.                               | Make sure it is within the following range.<br>$1/128 \leq \text{Numerator (2703h: 1)}/\text{Denominator (2703h: 2)} \leq 262,144$   | Correct the setting of <i>acceleration user unit (2703h)</i> .                      | –         |
| A40h:<br>System Initialization Error                | A failure occurred in the SERVOPACK.   | –  | Replace the SERVOPACK.  | –         |
| A41h:<br>Communications Device Initialization Error | A failure occurred in the SERVOPACK.   | –  | Replace the SERVOPACK.  | –         |

Continued on next page.

Continued from previous page.

| Alarm Code:<br>Alarm Name                   | Possible Cause   | Confirmation                                       | Correction  | Reference |
|---|--|--|---|-----------|
| A47h:<br>Loading Servo<br>Information Error | <i>User parameter configuration (2700h) was executed while a utility function (Fn□□□) was being executed from the Digital Operator or SigmaWin+.</i> | –  | Turn the power supply OFF and ON again.   | –         |
|   | The power supply was turned ON or <i>user parameter configuration (2700h) was executed when an encoder was not connected.</i>                        | Check the wiring of the encoder.                   | Turn OFF the power supply, correct the encoder connection, and then turn the power supply back ON.  | –         |
|   | The power supply was turned ON or <i>user parameter configuration (2700h) was executed when there was a Parameter Setting Error (alarm 040h).</i>    | Check the parameter settings.                      | Correct the parameter settings and turn the power supply OFF and ON again.  | –         |
|   | A failure occurred in the SERVOPACK.   | –  | Replace the SERVOPACK.  | –         |
| A48h:<br>EEPROM Parameter<br>Data Error     | The power supply was shut OFF while writing parameter settings.  | Check the timing of shutting OFF the power supply. | Initialize the parameter settings ( <i>restore default parameters (1011h)</i> ) and then set the parameters again.                            | –         |
|   | The number of times that parameters were written exceeded the limit.   | –  | Repair or replace the SERVOPACK. Reconsider the method for writing the parameters.  | –         |
|   | The power supply voltage suddenly dropped.   | Measure the power supply voltage.                  | Set the power supply voltage within the specified range, and initialize the parameter settings ( <i>restore default parameters (1011h)</i> ). | –         |
|   | A failure occurred in the SERVOPACK.   | –  | Replace the SERVOPACK.  | –         |
| A53h:<br>Axis Detect Error                  | –  | –  | –   | –         |
| b33h:<br>Current Detection<br>Error 3       | A failure occurred in the current detection circuit.   | –  | Turn the power supply to the SERVOPACK OFF and ON again. If an alarm still occurs, the SERVOPACK may be faulty. Replace the SERVOPACK.        | –         |
| bC0h:<br>System Alarm 10                    | A failure occurred in the SERVOPACK.   | –  | Turn the power supply to the SERVOPACK OFF and ON again. If an alarm still occurs, the SERVOPACK may be faulty. Replace the SERVOPACK.        | –         |
| bF0h:<br>System Alarm 0                     | A failure occurred in the SERVOPACK.   | –  | Turn the power supply to the SERVOPACK OFF and ON again. If an alarm still occurs, the SERVOPACK may be faulty. Replace the SERVOPACK.        | –         |

Continued on next page.

15.2 Alarm Displays

15.2.2 Troubleshooting Alarms

Continued from previous page.

| Alarm Code:<br>Alarm Name      | Possible Cause                       | Confirmation | Correction   | Reference |
|--------------------------------|--------------------------------------|--------------|--|-----------|
| <b>bF1h:</b><br>System Alarm 1 | A failure occurred in the SERVOPACK. | —            | Turn the power supply to the SERVOPACK OFF and ON again. If an alarm still occurs, the SERVOPACK may be faulty. Replace the SERVOPACK. | —         |
| <b>bF2h:</b><br>System Alarm 2 | A failure occurred in the SERVOPACK. | —            | Turn the power supply to the SERVOPACK OFF and ON again. If an alarm still occurs, the SERVOPACK may be faulty. Replace the SERVOPACK. | —         |
| <b>bF3h:</b><br>System Alarm 3 | A failure occurred in the SERVOPACK. | —            | Turn the power supply to the SERVOPACK OFF and ON again. If an alarm still occurs, the SERVOPACK may be faulty. Replace the SERVOPACK. | —         |
| <b>bF4h:</b><br>System Alarm 4 | A failure occurred in the SERVOPACK. | —            | Turn the power supply to the SERVOPACK OFF and ON again. If an alarm still occurs, the SERVOPACK may be faulty. Replace the SERVOPACK. | —         |
| <b>bF5h:</b><br>System Alarm 5 | A failure occurred in the SERVOPACK. | —            | Turn the power supply to the SERVOPACK OFF and ON again. If an alarm still occurs, the SERVOPACK may be faulty. Replace the SERVOPACK. | —         |
| <b>bF6h:</b><br>System Alarm 6 | A failure occurred in the SERVOPACK. | —            | Turn the power supply to the SERVOPACK OFF and ON again. If an alarm still occurs, the SERVOPACK may be faulty. Replace the SERVOPACK. | —         |
| <b>bF7h:</b><br>System Alarm 7 | A failure occurred in the SERVOPACK. | —            | Turn the power supply to the SERVOPACK OFF and ON again. If an alarm still occurs, the SERVOPACK may be faulty. Replace the SERVOPACK. | —         |
| <b>bF8h:</b><br>System Alarm 8 | A failure occurred in the SERVOPACK. | —            | Turn the power supply to the SERVOPACK OFF and ON again. If an alarm still occurs, the SERVOPACK may be faulty. Replace the SERVOPACK. | —         |

Continued on next page.

Continued from previous page.

| Alarm Code:<br>Alarm Name  | Possible Cause   | Confirmation   | Correction  | Reference |
|--|--|--|---|-----------|
| C10h:<br>Servomotor Out<br>of Control<br>(Detected when<br>the servo is<br>turned ON.) | The order of phases U, V, and W in the motor wiring is not correct.  | Check the Servomotor wiring.   | Make sure that the Servomotor is correctly wired.   | –         |
|  | There is an error in the setting of Pn080 (2080h) = n.□□X□ (Motor Phase Selection).                                | Check the setting of Pn080 (2080h) = n.□□X□.   | Set Pn080 (2080h) = n.□□X□ to an appropriate value.   | page 6-19 |
|  | A failure occurred in the encoder.   | –  | If the motor wiring is correct and an alarm still occurs after turning the power supply OFF and ON again, the Servomotor or linear encoder may be faulty. Replace the Servomotor or linear encoder. | –         |
|  | A failure occurred in the SERVOPACK.   | –  | Turn the power supply to the SERVOPACK OFF and ON again. If an alarm still occurs, the SERVOPACK may be faulty. Replace the SERVOPACK.  | –         |
| C20h:<br>Phase Detection<br>Error  | The linear encoder signal level is too low.  | Check the voltage of the linear encoder signal.  | Fine-tune the mounting of the scale head. Or, replace the linear encoder.   | –         |
|  | The count-up direction of the linear encoder does not match the forward direction of the Moving Coil in the motor. | Check the setting of Pn080 (2080h) = n.□□X□ (Motor Phase Sequence Selection). Check the installation orientation for the linear encoder and Moving Coil. | Change the setting of Pn080 (2080h) = n.□□X□. Correctly reinstall the linear encoder or Moving Coil.  | page 6-19 |
|  | The polarity sensor signal is being affected by noise.   | –  | Correct the FG wiring. Implement countermeasures against noise for the polarity sensor wiring.  | –         |
|  | The setting of Pn282 (2282h) (Linear Encoder Scale Pitch) is not correct.  | Check the setting of Pn282 (2282h) (Linear Encoder Scale Pitch).   | Check the specifications of the linear encoder and set a correct value.   | page 6-15 |
| C21h:<br>Polarity Sensor<br>Error  | The polarity sensor is protruding from the Magnetic Way of the motor.  | Check the polarity sensor.   | Correctly reinstall the Moving Coil or Magnetic Way of the motor.   | –         |
|  | The polarity sensor is not wired correctly.  | Check the wiring of the polarity sensor.   | Correct the wiring of the polarity sensor.  | –         |
|  | The polarity sensor failed.  | –  | Replace the polarity sensor.  | –         |
| C22h:<br>Phase Information<br>Disagreement   | The SERVOPACK phase information is different from the linear encoder phase information.                            | –  | Perform polarity detection.   | page 6-23 |

Continued on next page.

Continued from previous page.

| Alarm Code:<br>Alarm Name                          | Possible Cause  | Confirmation  | Correction  | Reference                       |
|--|---|---|---|---------------------------------|
| <p><b>C50h:</b><br/>Polarity Detection Failure</p> | <p>The parameter settings are not correct.</p>                        | <p>Check the linear encoder specifications and feedback signal status.</p>  | <p>The settings of Pn282 (2282h) (Linear Encoder Pitch) and Pn080 (2080h) = n.□□X□ (Motor Phase Selection) may not match the installation. Set the parameters to correct values.</p>  | <p>page 6-14,<br/>page 6-19</p> |
|  | <p>There is noise on the scale signal.</p>                            | <p>Check to make sure that the frame grounds of the Serial Converter Unit and Servomotor are connected to the FG terminal on the SERVOPACK and that the FG terminal on the SERVOPACK is connected to the frame ground on the power supply. And, confirm that the shield is properly processed on the Linear Encoder Cable. Check to see if the detection reference is repeatedly output in one direction.</p> | <p>Implement appropriate countermeasures against noise for the Linear Encoder Cable.</p>  | <p>–</p>                        |
|  | <p>An external force was applied to the Moving Coil of the motor.</p> | <p>–</p>  | <p>The polarity cannot be properly detected if the detection reference is 0 and the speed feedback is not 0 because of an external force, such as cable tension, applied to the Moving Coil. Implement measures to reduce the external force so that the speed feedback goes to 0. If the external force cannot be reduced, increase the setting of Pn481 (2481h) (Polarity Detection Speed Loop Gain).</p>                                   | <p>–</p>                        |
|  | <p>The linear encoder resolution is too low.</p>                      | <p>Check the linear encoder scale pitch to see if it is within 100 μm.</p>  | <p>If the linear encoder scale pitch is 100 μm or higher, the SERVOPACK cannot detect the correct speed feedback. Use a linear encoder scale pitch with higher resolution. (We recommend a pitch of 40 μm or less.) Or, increase the setting of Pn485 (2485h) (Polarity Detection Reference Speed). However, increasing the setting of Pn485 (2485h) will increase the Servomotor movement range that is required for polarity detection.</p> | <p>–</p>                        |

Continued on next page.

Continued from previous page.

| Alarm Code:<br>Alarm Name  | Possible Cause   | Confirmation                   | Correction  | Reference |
|--|--|--------------------------------|---|-----------|
| <b>C51h:</b><br>Overtravel<br>Detected during<br>Polarity Detection        | The overtravel signal was detected during polarity detection.  | Check the overtravel position. | Wire the overtravel signals. Execute polarity detection at a position where an overtravel signal would not be detected.   | page 4-39 |
| <b>C52h:</b><br>Polarity Detection Not Completed                           | The servo was turned ON when using an absolute linear encoder, Pn587 (2587h) was set to n.□□□0 (Do not detect polarity), and the polarity had not been detected. | –                              | When using an absolute linear encoder, set Pn587 (2587h) to n.□□□1 (Detect polarity).   | –         |
| <b>C53h:</b><br>Out of Range of<br>Motion for Polarity<br>Detection        | The travel distance exceeded the setting of Pn48E (248Eh) (Polarity Detection Range) in the middle of detection.   | –                              | Increase the setting of Pn48E (248Eh) (Polarity Detection Range). Or, increase the setting of Pn481 (2481h) (Polarity Detection Speed Loop Gain).   | –         |
| <b>C54h:</b><br>Polarity Detection Failure 2                               | An external force was applied to the Servomotor.   | –                              | Increase the setting of Pn495 (2495h) (Polarity Detection Confirmation Force Reference). Increase the setting of Pn498 (2498h) (Polarity Detection Allowable Error Range). Increasing the allowable error will also increase the motor temperature. | –         |
| <b>C80h:</b><br>Encoder Clear<br>Error or Multiturn<br>Limit Setting Error | A failure occurred in the encoder.   | –                              | Turn the power supply to the SERVOPACK OFF and ON again. If an alarm still occurs, the Servomotor or linear encoder may be faulty. Replace the Servomotor or linear encoder.  | –         |
|  | A failure occurred in the SERVOPACK.   | –                              | Turn the power supply to the SERVOPACK OFF and ON again. If an alarm still occurs, the SERVOPACK may be faulty. Replace the SERVOPACK.  | –         |

Continued on next page.

Continued from previous page.

| Alarm Code:<br>Alarm Name  | Possible Cause  | Confirmation   | Correction  | Reference |
|--|---|--|---|-----------|
| <b>C90h:</b><br>Encoder Communications Error                                 | There is a faulty contact in the connector or the connector is not wired correctly for the encoder.   | Check the condition of the encoder connector.            | Reconnect the encoder connector and check the encoder wiring.   | page 4-19 |
|  | There is a cable disconnection or short-circuit in the encoder. Or, the cable impedance is outside the specified values.  | Check the condition of the Encoder Cable.                | Use the Encoder Cable within the specified specifications.  | -         |
|  | One of the following has occurred: corrosion caused by improper temperature, humidity, or gas, a short-circuit caused by entry of water drops or cutting oil, or faulty contact in connector caused by vibration. | Check the operating environment.                         | Improve the operating environment, and replace the cable. If the alarm still occurs, replace the SERVOPACK.   | page 3-2  |
|  | A malfunction was caused by noise.  | -  | Correct the wiring around the encoder by separating the Encoder Cable from the Servomotor Main Circuit Cable or by grounding the encoder.                     | page 4-5  |
|  | A failure occurred in the SERVOPACK.  | -  | Connect the Servomotor to another SERVOPACK, and turn ON the control power supply. If no alarm occurs, the SERVOPACK may be faulty. Replace the SERVOPACK.    | -         |
|  | A failure occurred in the encoder.  | -  | Connect the Servomotor to another SERVOPACK, and turn ON the control power supply. If the alarm occurs, the Servomotor may be faulty. Replace the Servomotor. | -         |
| <b>C91h:</b><br>Encoder Communications Position Data Acceleration Rate Error | Noise entered on the signal lines because the Encoder Cable is bent or the sheath is damaged.   | Check the condition of the Encoder Cable and connectors. | Check the Encoder Cable to see if it is installed correctly.  | page 4-8  |
|  | The Encoder Cable is bundled with a high-current line or installed near a high-current line.  | Check the installation condition of the Encoder Cable.   | Confirm that there is no surge voltage on the Encoder Cable.  | -         |
|  | There is variation in the FG potential because of the influence of machines on the Servomotor side, such as a welder.   | Check the installation condition of the Encoder Cable.   | Properly ground the machine to separate it from the FG of the encoder.  | -         |

Continued on next page.



Continued from previous page.

| Alarm Code:<br>Alarm Name                           | Possible Cause   | Confirmation                    | Correction   | Reference |
|---|--|---------------------------------|--|-----------|
| C92h:<br>Encoder Commu-<br>nications Timer<br>Error | Noise entered on the signal line from the encoder.       | –                               | Implement countermeasures against noise for the encoder wiring.  | page 4-5  |
|   | Excessive vibration or shock was applied to the encoder. | Check the operating conditions. | Reduce machine vibration.<br>Correctly install the Servomotor or linear encoder.   | –         |
|   | A failure occurred in the encoder.                       | –                               | Turn the power supply to the SERVOPACK OFF and ON again. If an alarm still occurs, the Servomotor or linear encoder may be faulty. Replace the Servomotor or linear encoder. | –         |
|   | A failure occurred in the SERVOPACK.                     | –                               | Turn the power supply to the SERVOPACK OFF and ON again. If an alarm still occurs, the SERVOPACK may be faulty. Replace the SERVOPACK.                                       | –         |
| CA0h:<br>Encoder Parame-<br>ter Error               | A failure occurred in the encoder.                       | –                               | Turn the power supply to the SERVOPACK OFF and ON again. If an alarm still occurs, the Servomotor or linear encoder may be faulty. Replace the Servomotor or linear encoder. | –         |
|   | A failure occurred in the SERVOPACK.                     | –                               | Turn the power supply to the SERVOPACK OFF and ON again. If an alarm still occurs, the SERVOPACK may be faulty. Replace the SERVOPACK.                                       | –         |

Continued on next page.

Continued from previous page.

| Alarm Code:<br>Alarm Name             | Possible Cause   | Confirmation   | Correction   | Reference |
|---------------------------------------|--|--|--|-----------|
| Cb0h:<br>Encoder Echo-back Error      | The encoder is wired incorrectly or there is faulty contact.   | Check the wiring of the encoder.                         | Make sure that the encoder is correctly wired.   | page 4-19 |
|                                       | The specifications of the Encoder Cable are not correct and noise entered on it.   | –  | Use a shielded twisted-pair wire cable or a screened twisted-pair cable with conductors of at least 0.12 mm <sup>2</sup> .   | –         |
|                                       | The Encoder Cable is too long and noise entered on it.   | –  | <ul style="list-style-type: none"> <li>Rotary Servomotors: The Encoder Cable wiring distance must be 50 m max.</li> <li>Linear Servomotors: The Encoder Cable wiring distance must be 20 m max.</li> </ul> | –         |
|                                       | There is variation in the FG potential because of the influence of machines on the Servomotor side, such as a welder.                  | Check the condition of the Encoder Cable and connectors. | Properly ground the machine to separate it from the FG of the encoder.   | –         |
|                                       | Excessive vibration or shock was applied to the encoder.   | Check the operating conditions.                          | Reduce machine vibration. Correctly install the Servomotor or linear encoder.  | –         |
|                                       | A failure occurred in the encoder.   | –  | Turn the power supply to the SERVOPACK OFF and ON again. If an alarm still occurs, the Servomotor or linear encoder may be faulty. Replace the Servomotor or linear encoder.                               | –         |
|                                       | A failure occurred in the SERVOPACK.   | –  | Turn the power supply to the SERVOPACK OFF and ON again. If an alarm still occurs, the SERVOPACK may be faulty. Replace the SERVOPACK.   | –         |
| CC0h:<br>Multiturn Limit Disagreement | The multiturn limit of the encoder is different from that of the SERVOPACK. Or, the multiturn limit of the SERVOPACK has been changed. | Check the setting of Pn205 (2205h) (Multiturn Limit).    | Change the setting if the alarm occurs.  | page 7-31 |
|                                       | A failure occurred in the SERVOPACK.   | –  | Turn the power supply to the SERVOPACK OFF and ON again. If an alarm still occurs, the SERVOPACK may be faulty. Replace the SERVOPACK.   | –         |

Continued on next page.

Continued from previous page.

| Alarm Code:<br>Alarm Name   | Possible Cause   | Confirmation   | Correction   | Reference |
|---|--|--|--|-----------|
| <b>CF1h:</b><br>Reception Failed<br>Error in Feed-<br>back Option<br>Module Commu-<br>nications   | The cable between the Serial Converter Unit and SERVOPACK is not wired correctly or there is a faulty contact. | Check the wiring of the external encoder.                                | Correctly wire the cable between the Serial Converter Unit and SERVOPACK.  | page 4-22 |
|   | A specified cable is not being used between Serial Converter Unit and SERVOPACK.                               | Check the wiring specifications of the external encoder.                 | Use a specified cable.   | -         |
|   | The cable between the Serial Converter Unit and SERVOPACK is too long.   | Measure the length of the cable that connects the Serial Converter Unit. | The length of the cable between the Serial Converter Unit and SERVOPACK must be 20 m or less.  | -         |
|   | The sheath on cable between the Serial Converter Unit and SERVOPACK is broken.                                 | Check the cable that connects the Serial Converter Unit.                 | Replace the cable between the Serial Converter Unit and SERVOPACK.   | -         |
| <b>CF2h:</b><br>Timer Stopped<br>Error in Feed-<br>back Option<br>Module Commu-<br>nications  | Noise entered the cable between the Serial Converter Unit and SERVOPACK.                                       | -  | Correct the wiring around the Serial Converter Unit, e.g., separate I/O signal lines from the Main Circuit Cables or ground.           | -         |
|   | A failure occurred in the Serial Converter Unit.   | -  | Replace the Serial Converter Unit.   | -         |
|   | A failure occurred in the SERVOPACK.   | -  | Replace the SERVOPACK.   | -         |
| <b>d00h:</b><br>Position Devia-<br>tion Overflow<br>(The setting of Pn520 (2520h) (Excessive Position Error Alarm Level) was exceeded by the position deviation.) | The Servomotor U, V, and W wiring is not correct.  | Check the wiring of the Servomotor's Main Circuit Cables.                | Make sure that there are no faulty contacts in the wiring for the Servomotor and encoder.  | -         |
|   | The position command speed is too fast.  | Reduce the position command speed and try operating the SERVOPACK.       | Reduce the position reference speed or the reference acceleration rate, or reconsider the electronic gear ratio.                       | page 6-41 |
|   | The acceleration of the position reference is too high.  | Reduce the reference acceleration and try operating the SERVOPACK.       | Reduce the acceleration of the position reference using an EtherCAT command.   | -         |
|   | The setting of Pn520 (2520h) (Position Deviation Alarm Level) is too low for the operating conditions.         | Check the setting of Pn520 (2520h) to see if it is appropriate.          | Optimize the setting of Pn520 (2520h).   | page 9-8  |
|   | A failure occurred in the SERVOPACK.   | -  | Turn the power supply to the SERVOPACK OFF and ON again. If an alarm still occurs, the SERVOPACK may be faulty. Replace the SERVOPACK. | -         |

Continued on next page.

15.2 Alarm Displays

15.2.2 Troubleshooting Alarms

Continued from previous page.

| Alarm Code:<br>Alarm Name   | Possible Cause  | Confirmation   | Correction   | Reference |
|---|---|--|--|-----------|
| <b>d01h:</b><br>Position Deviation Overflow Alarm at Servo ON                 | The servo was turned ON after the position deviation exceeded the setting of Pn526 (2526h) (Position Deviation Alarm Level at Servo ON) while the servo was OFF.  | Check the position deviation while the servo is OFF.                         | Optimize the setting of Pn526 (2526h).   |           |
| <b>d02h:</b><br>Position Deviation Overflow Alarm for Speed Limit at Servo ON | If position deviation remains in the deviation counter, the setting of Pn529 (2529h) or Pn584 (2584h) (Speed Limit Level at Servo ON) limits the speed when the servo is turned ON. This alarm occurs if a position reference is input and the setting of Pn520 (2520h) (Position Deviation Alarm Level) is exceeded. | –  | Optimize the setting of Pn520 (2520h). Or, set Pn529 (2529h) or Pn584 (2584h) to an appropriate value.   | page 9-8  |
| <b>d10h:</b><br>Motor-Load Position Deviation Overflow                        | The motor direction and external encoder installation orientation are backward.   | Check the motor direction and the external encoder installation orientation. | Install the external encoder in the opposite direction, or change the setting of Pn002 (2002h) = n.X□□□ (External Encoder Usage) to reverse the direction. | page 11-7 |
|   | There is an error in the connection between the load (e.g., stage) and external encoder coupling.   | Check the coupling of the external encoder.                                  | Check the mechanical coupling.   | –         |
| <b>d30h:</b><br>Position Data Overflow  | The position data exceeded ±1,879,048,192.  | Check the input reference pulse counter.                                     | Reconsider the operating specifications.   | –         |
| <b>E00h:</b><br>EtherCAT Module Interface Initialization Timeout Error        | A failure occurred in the SERVOPACK.  | –  | Replace the SERVOPACK.   | –         |
| <b>E02h:</b><br>EtherCAT Internal Synchronization Error 1                     | The EtherCAT transmission cycle fluctuated.   | –  | Remove the cause of transmission cycle fluctuation at the host controller.   | –         |
|   | A failure occurred in the SERVOPACK.  | –  | Turn the power supply to the SERVOPACK OFF and ON again. If an alarm still occurs, the SERVOPACK may be faulty. Replace the SERVOPACK.                     | –         |
| <b>E03h:</b><br>EtherCAT Module Interface Communications Data Error           | Noise caused an error in communications between the SERVOPACK and EtherCAT Network Module.  | –  | Implement countermeasures against noise.   | –         |
|   | A failure occurred in the SERVOPACK.  | –  | Replace the SERVOPACK.   | –         |

Continued on next page.

Continued from previous page.

| Alarm Code:<br>Alarm Name  | Possible Cause   | Confirmation  | Correction   | Reference |
|--|--|---|--|-----------|
| <b>EA0h:</b><br>Command-Option IF Servo Unit Initial Error   | A failure occurred in the SERVOPACK.   | –   | Replace the SERVO-PACK.  | –         |
| <b>EA1h:</b><br>Command-Option IF Memory Check Error   | A failure occurred in the SERVOPACK.   | –   | Replace the SERVO-PACK.  | –         |
| <b>EA2h:</b><br>Command-Option IF Servo Synchronization Error  | Fluctuation in the EtherCAT communications synchronization timing (Sync0) caused the synchronization timing in the SERVOPACK to fluctuate. | –   | Turn the power supply OFF and ON again and re-establish communications.  | –         |
|  | A failure occurred in the SERVOPACK.   | –   | Repair or replace the SERVOPACK.   | –         |
| <b>EA3h:</b><br>Command-Option IF Servo Data Error   | Noise caused an error in communications in the SERVOPACK.  | –   | Implement countermeasures against noise.   | –         |
|  | A failure occurred in the SERVOPACK.   | –   | Replace the SERVO-PACK.  | –         |
| <b>Eb1h:</b><br>Safety Function Signal Input Timing Error  | The delay between activation of the /HWBB1 and /HWBB2 input signals for the HWBB was ten second or longer.                                 | Measure the time delay between the /HWBB1 and /HWBB2 signals.       | The output signal circuits or devices for /HWBB1 and /HWBB2 or the SERVOPACK input signal circuits may be faulty. Alternatively, the input signal cables may be disconnected. Check to see if any of these items are faulty or have been disconnected. | –         |
|  | A failure occurred in the SERVOPACK.   | –   | Replace the SERVO-PACK.  | –         |
| <b>EC8h:</b><br>Gate Drive Error 1<br>(An error occurred in the gate drive circuit.)   | A failure occurred in the SERVOPACK.   | –   | Turn the power supply to the SERVOPACK OFF and ON again. If an alarm still occurs, the SERVOPACK may be faulty. Replace the SERVOPACK.   | –         |
| <b>EC9h:</b><br>Gate Drive Error 2<br>(An error occurred in the gate drive circuit.)   |  |   |  |           |
| <b>F10h:</b><br>Power Supply Line Open Phase<br>(The voltage was low for more than one second for phase R, S, or T when the main power supply was ON.) | The three-phase power supply wiring is not correct.  | Check the power supply wiring.                                      | Make sure that the power supply is correctly wired.  | page 4-11 |
|  | The three-phase power supply is unbalanced.  | Measure the voltage for each phase of the three-phase power supply. | Balance the power supply by changing phases.   | –         |
|  | A failure occurred in the SERVOPACK.   | –   | Turn the power supply to the SERVOPACK OFF and ON again. If an alarm still occurs, the SERVOPACK may be faulty. Replace the SERVOPACK.   | –         |

Continued on next page.

15.2 Alarm Displays

15.2.2 Troubleshooting Alarms

Continued from previous page.

| Alarm Code:<br>Alarm Name                         | Possible Cause   | Confirmation                 | Correction   | Reference |
|---|--|------------------------------|--|-----------|
| FL-1*3:<br>System Alarm                           | A failure occurred in the SERVOPACK.   | -                            | Turn the power supply to the SERVOPACK OFF and ON again. If an alarm still occurs, the SERVOPACK may be faulty. Replace the SERVOPACK.                 | -         |
| FL-2*3:<br>System Alarm                           |  |                              |  |           |
| FL-3*3:<br>System Alarm                           |  |                              |  |           |
| FL-4*3:<br>System Alarm                           |  |                              |  |           |
| FL-5*3:<br>System Alarm                           |  |                              |  |           |
| FL-6*3:<br>System Alarm                           |  |                              |  |           |
| FL-7*3:<br>System Alarm                           |  |                              |  |           |
| CPF00:<br>Digital Operator Communications Error 1 | There is a faulty connection between the Digital Operator and the SERVOPACK. | Check the connector contact. | Disconnect the connector and insert it again. Or, replace the cable.   | -         |
|   | A malfunction was caused by noise.   | -                            | Keep the Digital Operator or the cable away from sources of noise.   | -         |
| CPF01:<br>Digital Operator Communications Error 2 | A failure occurred in the Digital Operator.                                  | -                            | Disconnect the Digital Operator and then connect it again. If an alarm still occurs, the Digital Operator may be faulty. Replace the Digital Operator. | -         |
|   | A failure occurred in the SERVOPACK.   | -                            | Turn the power supply to the SERVOPACK OFF and ON again. If an alarm still occurs, the SERVOPACK may be faulty. Replace the SERVOPACK.                 | -         |

\*1. Detection Conditions

• Rotary Servomotor

If either of the following conditions is detected, an alarm will occur.

•  $Pn533 [min^{-1}] \times \frac{\text{Encoder resolution}}{6 \times 10^5} \leq 1$

•  $\text{Maximum motor speed } [min^{-1}] \times \frac{\text{Encoder resolution}}{\text{Approx. } 3.66 \times 10^{12}} \geq 1$

• Linear Servomotor

If either of the following conditions is detected, an alarm will occur.

•  $\frac{Pn585 [mm/s]}{\text{Linear encoder pitch } [\mu m]} \times \frac{\text{Resolution of Serial Converter Unit}}{10} \leq 1$

•  $\frac{Pn385 [100 mm/s]}{\text{Linear encoder pitch } [\mu m]} \times \frac{\text{Resolution of Serial Converter Unit}}{\text{Approx. } 6.10 \times 10^5} \geq 1$

\*2. Refer to the catalog for details.

\*3. These alarms are not stored in the alarm history. They are only displayed on the panel display.

## 15.2.3 Resetting Alarms

If there is an ALM (Servo Alarm) signal, use one of the following methods to reset the alarm after eliminating the cause of the alarm.



**Important**

Be sure to eliminate the cause of an alarm before you reset the alarm. If you reset the alarm and continue operation without eliminating the cause of the alarm, it may result in damage to the equipment or fire.

### Resetting Alarms with the SigmaWin+

Use the following procedure to reset alarms with the SigmaWin+.

1. Click the  Servo Drive Button in the workspace of the Main Window of the SigmaWin+.
2. Select **Display Alarm** in the Menu Dialog Box. The Alarm Display Dialog Box will be displayed.
3. Click the **Reset axes** Button.

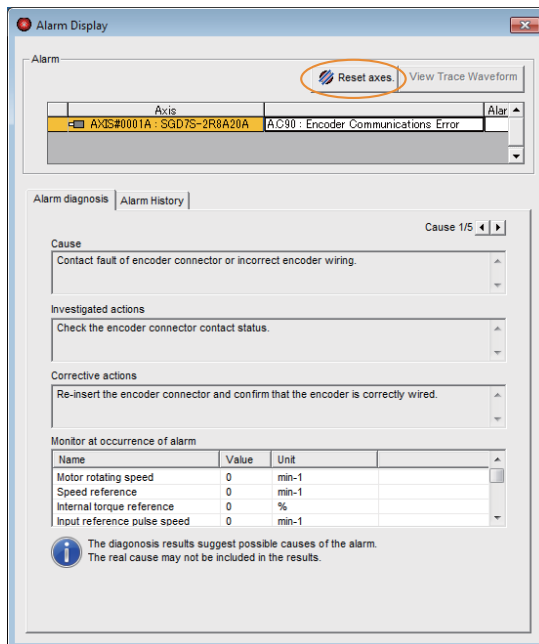

The alarm will be reset, and the alarm display will be cleared.

This concludes the procedure to reset alarms.

### Clearing Alarms with the Fault Reset Command

Execute the Fault Reset command to clear alarms or warnings.

Refer to the following section for details on the Fault Reset command.

 **Control word Bits** on page 14-28

### Resetting Alarms Using the Digital Operator

Press the **ALARM RESET** Key on the Digital Operator. Refer to the following manual for details on resetting alarms.

 **Σ-7-Series Digital Operator Operating Manual** (Manual No.: SIEP S800001 33)

## 15.2.4 Displaying the Alarm History

The alarm history displays up to the last ten alarms that have occurred in the SERVOPACK. Alarms are displayed for the selected axis.

Note: The following alarms are not displayed in the alarm history: A.E50 (EtherCAT Synchronization Error) and FL-1 to FL-7.

### Preparations

No preparations are required.

### Applicable Tools

The following table lists the tools that you can use to display the alarm history.

| Tool             | Fn No./Function Name                   | Reference  |
|------------------|--|--|
| Digital Operator | Fn000                                  | Σ-7-Series Digital Operator Operating Manual (Manual No.: S1EP S800001 33) |
| SigmaWin+        | <i>Troubleshooting – Display Alarm</i> | <i>Operating Procedure</i> on page 15-42                                   |

### Operating Procedure

Use the following procedure to display the alarm history.

1. Click the Servo Drive Button in the workspace of the Main Window of the SigmaWin+.
2. Select **Display Alarm** in the Menu Dialog Box.  
The Alarm Display Dialog Box will be displayed.
3. Click the **Alarm History** Tab.  
The following display will appear and you can check the alarms that occurred in the past.

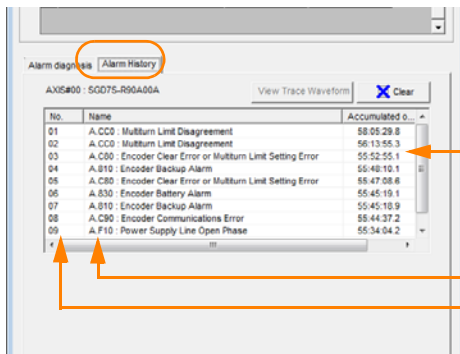

Accumulated operation time  
Total operation time to the point at which the alarm occurred is displayed in increments of 100 ms from when the control power supply and main circuit power supply turned ON.  
For 24-hour, 365-day operation, measurements are possible for approximately 13 years.

Alarm number: Alarm name  
Alarms in order of occurrence  
(Older alarms have higher numbers.)

**Information**

1. If the same alarm occurs consecutively within one hour, it is not saved in the alarm history. If it occurs after an hour or more, it is saved.
2. You can clear the alarm history by clicking the **Clear** Button. The alarm history is not cleared when alarms are reset or when the SERVOPACK main circuit power is turned OFF.

This concludes the procedure to display the alarm history.



## 15.2.5 Clearing the Alarm History

You can clear the alarm history that is recorded in the SERVOPACK. You can specify the axis for which to delete the history.

The alarm history is not cleared when alarms are reset or when the SERVOPACK main circuit power is turned OFF. You must perform the following procedure.



### Preparations

Always check the following before you clear the alarm history.

- The parameters must not be write prohibited.

### Applicable Tools

The following table lists the tools that you can use to clear the alarm history.

| Tool             | Fn No./Function Name                   | Reference   |
|------------------|--|---|
| Digital Operator | Fn006                                  |  $\Sigma$ -7-Series Digital Operator Operating Manual (Manual No.: SIEP S800001 33) |
| SigmaWin+        | <i>Troubleshooting – Display Alarm</i> |  <i>Operating Procedure</i> on page 15-43   |

### Operating Procedure

Use the following procedure to reset the alarm history.

1. Click the  Servo Drive Button in the workspace of the Main Window of the SigmaWin+.
2. Select **Display Alarm** in the Menu Dialog Box.  
The Alarm Display Dialog Box will be displayed.
3. Click the **Alarm History** Tab.
4. Click the **Clear** Button.  
The alarm history will be cleared.

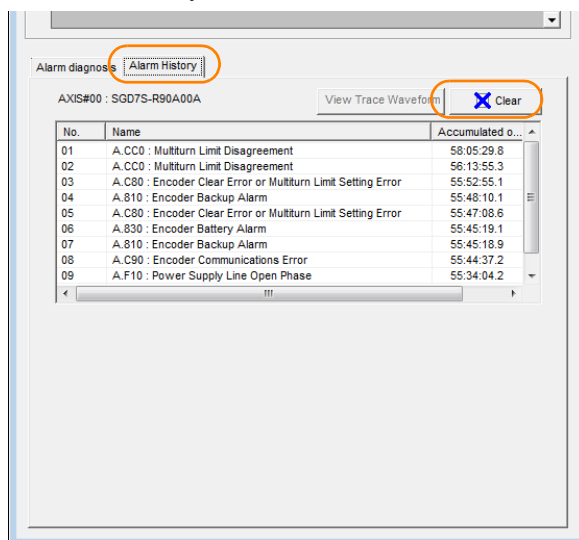

This concludes the procedure to reset the alarm history.

## 15.2.6 Resetting Motor Type Alarms

The SERVOPACK automatically determines the type of motor that is connected to it. If the type of motor that is connected is changed, an A.070 alarm (Motor Type Change Detected) will occur the next time the SERVOPACK is started. If an A.070 alarm occurs, you must set the parameters to match the new type of motor.

An A.070 alarm is reset by executing the Reset Motor Type Alarm utility function.

- Information**
1. This utility function is the only way to reset an A.070 alarm (Motor Type Change Detected). The errors are not reset when you reset alarms or turn OFF the power supply to the SERVOPACK.
  2. If an A.070 alarm occurs, first set the parameters according to the newly connected motor type and then execute the Reset Motor Type Alarm utility function.



### Preparations

Always check the following before you reset a motor type alarm.

- The parameters must not be write prohibited.

### Applicable Tools

The following table lists the tools that you can use to clear the motor type alarm.

| Tool             | Fn No./Function Name                            | Reference   |
|------------------|---|---|
| Digital Operator | Fn021   |  $\Sigma$ -7-Series Digital Operator Operating Manual (Manual No.: SIEP S800001 33) |
| SigmaWin+        | <b>Troubleshooting – Reset Motor Type Alarm</b> |  Operating Procedure on page 15-44   |

### Operating Procedure

Use the following procedure to reset Motor Type alarm.

1. Click the  Servo Drive Button in the workspace of the Main Window of the SigmaWin+.
2. Select **Reset Motor Type Alarm** in the Menu Dialog Box. The Reset Motor Type Alarm Dialog Box will be displayed.
3. Click the **Reset** Button.

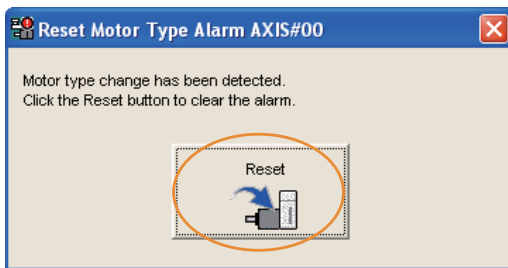

4. Read the precaution and then click the **OK** Button.

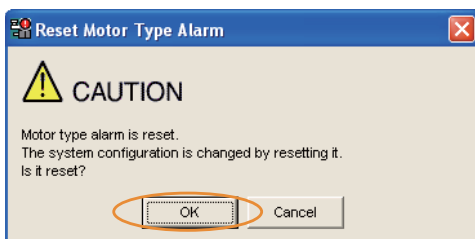

5. Read the precaution and then click the OK Button.

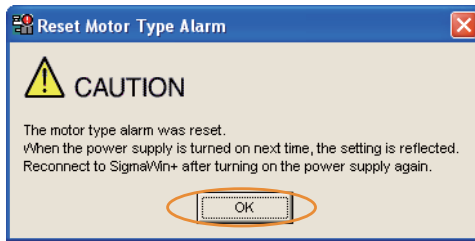

6. Turn the power supply to the SERVOPACK OFF and ON again.

This concludes the procedure to reset Motor Type alarms.

## 15.3 Warning Displays

If a warning occurs in the SERVOPACK, a warning number will be displayed on the panel display. Warnings are displayed to warn you before an alarm occurs.

This section provides a list of warnings and the causes of and corrections for warnings.

### 15.3.1 List of Warnings

The list of warnings gives the warning name and warning meaning in order of the warning numbers.

If “Common” is given below the warning number, the warning applies to both axes. If a warning occurs for one axis, the same warning status will occur for the other axis.

| Warning Number | Warning Name   | Meaning   | Resetting |
|----------------|--|---|-----------|
| 900h           | Position Deviation Overflow                                      | The position deviation exceeded the parameter settings (Pn520 × Pn51E/100).   | Required. |
| 901h           | Position Deviation Overflow Alarm at Servo ON                    | The position deviation exceeded the parameter settings (Pn526 × Pn528/100) when the servo was turned ON.  | Required. |
| 910h           | Overload   | This warning occurs before an overload alarm (A.710 or A.720) occurs. If the warning is ignored and operation is continued, an alarm may occur.   | Required. |
| 911h           | Vibration  | Abnormal vibration was detected during motor operation. The detection level is the same as A.520. Set whether to output an alarm or a warning by setting Pn310 (Vibration Detection Selection). | Required. |
| 912h<br>Common | Internal Temperature Warning 1 (Control Board Temperature Error) | The surrounding temperature of the control PCB is abnormal.   | Required. |
| 913h<br>Common | Internal Temperature Warning 2 (Power Board Temperature Error)   | The surrounding temperature of the power PCB is abnormal.   | Required. |
| 920h<br>Common | Regenerative Overload  | This warning occurs before an A.320 alarm (Regenerative Overload) occurs. If the warning is ignored and operation is continued, an alarm may occur.   | Required. |
| 921h           | Dynamic Brake Overload   | This warning occurs before an A.731 alarm (Dynamic Brake Overload) occurs. If the warning is ignored and operation is continued, an alarm may occur.  | Required. |
| 923h<br>Common | SERVOPACK Built-in Fan Stopped                                   | The fan inside the SERVOPACK stopped.   | Required. |
| 930h           | Absolute Encoder Battery Error                                   | This warning occurs when the voltage of absolute encoder's battery is low.  | Required. |
| 93Bh           | Overheat Warning   | The input voltage (temperature) for the overheat protection input (TH) signal exceeded the setting of Pn61C (261Ch) (Overheat Warning Level).   | Required. |
| 942h           | Speed Ripple Compensation Information Disagreement               | The speed ripple compensation information stored in the encoder does not agree with the speed ripple compensation information stored in the SERVOPACK.  | Required. |
| 971h<br>Common | Undervoltage   | This warning occurs before an A.410 alarm (Undervoltage) occurs. If the warning is ignored and operation is continued, an alarm may occur.  | Required. |
| 9A0h           | Overtravel   | Overtravel was detected while the servo was ON.   | Required. |
| 9b0h<br>Common | Preventative Maintenance Warning                                 | One of the consumable parts has reached the end of its service life.  | Required. |

Note: Use Pn008 = n.□X□□ (Warning Detection Selection) to control warning detection. However, the following warnings are not affected by the setting of Pn008 = n.□X□□ and other parameter settings are required in addition to Pn008 = n.□X□□.

| Warning | Parameters That Must Be Set to Select Warning Detection   | Reference  |
|---------|---|------------|
| A.911   | Pn310 = n.□□□X (Vibration Detection Selection)  | page 7-37  |
| A.923   | –<br>(Not affected by the setting of Pn008 = n.□X□□.)   | –          |
| A.930   | Pn008 = n.□□□X (Low Battery Voltage Alarm/Warning Selection)  | page 15-3  |
| A.942   | Pn423 = n.□□□X (Speed Ripple Compensation Information Disagreement Warning Detection Selection)             | page 9-59  |
| A.971   | Pn008 = n.□□□X (Function Selection for Undervoltage)<br>(Not affected by the setting of Pn008 = n.□X□□.)    | page 7-19  |
| A.9A0   | Pn00D = n.X□□□ (Overtravel Warning Detection Selection)<br>(Not affected by the setting of Pn008 = n.□X□□.) | page 6-28  |
| A.9b0   | Pn00F = n.□□□X (Preventative Maintenance Warning Selection)   | page 10-15 |

## 15.3.2 Troubleshooting Warnings

The causes of and corrections for the warnings are given in the following table. Contact your Yaskawa representative if you cannot solve a problem with the correction given in the table.

| Warning Number:<br>Warning Name                              | Possible Cause  | Confirmation  | Correction   | Reference |
|--|---|---|--|-----------|
| 900h:<br>Position Deviation<br>Overflow                      | The Servomotor U, V, and W wiring is not correct.   | Check the wiring of the Servomotor's Main Circuit Cables.   | Make sure that there are no faulty connections in the wiring for the Servomotor and encoder.   | –         |
|  | A SERVOPACK gain is too low.  | Check the SERVO-PACK gains.   | Increase the servo gain, e.g., by using autotuning without a host reference.   | page 9-24 |
|  | The acceleration of the position reference is too high.   | Reduce the reference acceleration and try operating the SERVO-PACK.   | Reduce the acceleration of the position reference using a EtherCAT command.  | –         |
|  | The excessive position deviation alarm level (Pn520 (2520h) × Pn51E (251Eh)/100) is too low for the operating conditions. | Check excessive position deviation alarm level (Pn520 × Pn51E/100) to see if it is set to an appropriate value. | Optimize the settings of Pn520 and Pn51E.  | page 9-8  |
|  | A failure occurred in the SERVO-PACK.   | –   | Turn the power supply to the SERVOPACK OFF and ON again. If an alarm still occurs, the SERVOPACK may be faulty. Replace the SERVOPACK. | –         |
| 901h:<br>Position Deviation<br>Overflow Alarm at<br>Servo ON | The position deviation exceeded the parameter settings (Pn526 (2526h) × Pn528 (2528h)/100) when the servo was turned ON.  | –   | Optimize the setting of Pn528 (Position Deviation Overflow Warning Level at Servo ON).   | –         |

Continued on next page.

Continued from previous page.

| Warning Number:<br>Warning Name  | Possible Cause  | Confirmation   | Correction   | Reference |
|--|---|--|--|-----------|
| <b>910h:</b><br>Overload (warning before an A.710 or A.720 alarm occurs) | The wiring is not correct or there is a faulty connection in the motor or encoder wiring.                                   | Check the wiring.  | Make sure that the Servomotor and encoder are correctly wired.                 | -         |
|  | Operation was performed that exceeded the overload protection characteristics.  | Check the motor overload characteristics and Run command.                                  | Reconsider the load and operating conditions. Or, increase the motor capacity. | -         |
|  | An excessive load was applied during operation because the Servomotor was not driven because of mechanical problems.        | Check the operation reference and motor speed.   | Remove the mechanical problem.   | -         |
|  | The overload warning level (Pn52B (252Bh)) is not suitable.   | Check that the overload warning level (Pn52B) is suitable.                                 | Set a suitable overload warning level (Pn52B).                                 | page 6-39 |
|  | A failure occurred in the SERVOPACK.  | -  | The SERVOPACK may be faulty. Replace the SERVOPACK.                            | -         |
| <b>911h:</b><br>Vibration  | Abnormal vibration was detected during motor operation.   | Check for abnormal motor noise, and check the speed and torque waveforms during operation. | Reduce the motor speed. Or, reduce the servo gain with custom tuning.          | page 9-42 |
|  | The setting of Pn103 (2103h) (Moment of Inertia Ratio) is greater than the actual moment of inertia or was greatly changed. | Check the moment of inertia ratio or mass ratio.   | Set Pn103 (Moment of Inertia Ratio) to an appropriate value.                   | page 9-16 |
|  | The vibration detection level (Pn312 (2312h) or Pn384 (2384h)) is not suitable.   | Check that the vibration detection level (Pn312 or Pn384) is suitable.                     | Set a suitable vibration detection level (Pn312 or Pn384).                     | page 7-37 |

Continued on next page.

Continued from previous page.

| Warning Number:<br>Warning Name  | Possible Cause   | Confirmation  | Correction   | Reference             |
|--|--|---|--|-----------------------|
| 912h:<br>Internal Temperature Warning 1<br>(Control Board Temperature Error) | The surrounding temperature is too high.   | Check the surrounding temperature using a thermometer. Or, check the operating status with the SERVOPACK installation environment monitor.            | Decrease the surrounding temperature by improving the SERVOPACK installation conditions. | page 3-6              |
|  | An overload alarm was reset by turning OFF the power supply too many times.                                | Check the alarm display to see if there is an overload alarm.   | Change the method for resetting the alarm.   | –                     |
|  | There was an excessive load or operation was performed that exceeded the regenerative processing capacity. | Use the accumulated load ratio to check the load during operation, and use the regenerative load ratio to check the regenerative processing capacity. | Reconsider the load and operating conditions.  | –                     |
|  | The SERVOPACK installation orientation is not correct or there is insufficient space around the SERVOPACK. | Check the SERVOPACK installation conditions.  | Install the SERVOPACK according to specifications.                                       | page 3-3,<br>page 3-5 |
|  | A failure occurred in the SERVOPACK.   | –   | The SERVOPACK may be faulty. Replace the SERVOPACK.                                      | –                     |
| 913h:<br>Internal Temperature Warning 2<br>(Power Board Temperature Error)   | The surrounding temperature is too high.   | Check the surrounding temperature using a thermometer. Or, check the operating status with the SERVOPACK installation environment monitor.            | Decrease the surrounding temperature by improving the SERVOPACK installation conditions. | page 3-6              |
|  | An overload alarm was reset by turning OFF the power supply too many times.                                | Check the alarm display to see if there is an overload alarm.   | Change the method for resetting the alarm.   | –                     |
|  | There was an excessive load or operation was performed that exceeded the regenerative processing capacity. | Use the accumulated load ratio to check the load during operation, and use the regenerative load ratio to check the regenerative processing capacity. | Reconsider the load and operating conditions.  | –                     |
|  | The SERVOPACK installation orientation is not correct or there is insufficient space around the SERVOPACK. | Check the SERVOPACK installation conditions.  | Install the SERVOPACK according to specifications.                                       | page 3-3,<br>page 3-5 |
|  | A failure occurred in the SERVOPACK.   | –   | The SERVOPACK may be faulty. Replace the SERVOPACK.                                      | –                     |

Continued on next page.

15.3 Warning Displays

15.3.2 Troubleshooting Warnings

Continued from previous page.

| Warning Number:<br>Warning Name  | Possible Cause  | Confirmation  | Correction  | Reference |
|--|---|---|---|-----------|
| <b>920h:</b><br>Regenerative Overload (warning before an A.320 (320h) alarm occurs)  | The power supply voltage exceeded the specified range.  | Measure the power supply voltage.   | Set the power supply voltage within the specified range.  | -         |
|  | There is insufficient external regenerative resistance, Regenerative Resistor capacity, or SERVOPACK capacity, or there has been a continuous regeneration state. | Check the operating conditions and capacity again.                                      | Change the regenerative resistance value, regenerative resistance capacity, or SERVOPACK capacity. Recheck the operating conditions.  | -         |
|  | There was a continuous regeneration state because a negative load was continuously applied.   | Check the load applied to the Servomotor during operation.                              | Reconsider the system including the servo, machine, and operating conditions.   | -         |
| <b>921h:</b><br>Dynamic Brake Overload (warning before an A.731 (731h) alarm occurs)   | The Servomotor was rotated by an external force.  | Check the operation status.   | Implement measures to ensure that the motor will not be rotated by an external force.   | -         |
|  | When the Servomotor was stopped with the dynamic brake, the rotational or linear kinetic energy exceeded the capacity of the Dynamic Brake Resistor.              | Check the power consumed by the DB resistor to see how frequently the DB is being used. | Reconsider the following: <ul style="list-style-type: none"> <li>• Reduce the Servomotor command speed.</li> <li>• Decrease the moment of inertia or mass.</li> <li>• Reduce the frequency of stopping with the dynamic brake.</li> </ul> | -         |
|  | A failure occurred in the SERVOPACK.  | -   | The SERVOPACK may be faulty. Replace the SERVOPACK.   | -         |
| <b>923h:</b><br>SERVOPACK Built-in Fan Stopped   | The fan inside the SERVOPACK stopped.   | Check for foreign matter inside the SERVOPACK.  | Remove foreign matter from the SERVOPACK. If an alarm still occurs, the SERVOPACK may be faulty. Replace the SERVOPACK.   | -         |
| <b>930h:</b><br>Absolute Encoder Battery Error (The absolute encoder battery voltage was lower than the specified level.) (Detected only when an absolute encoder is connected.) | The battery connection is faulty or a battery is not connected.   | Check the battery connection.   | Correct the battery connection.   | page 4-20 |
|  | The battery voltage is lower than the specified value (2.7 V).  | Measure the battery voltage.  | Replace the battery.  | page 15-3 |
|  | A failure occurred in the SERVOPACK.  | -   | The SERVOPACK may be faulty. Replace the SERVOPACK.   | -         |

Continued on next page.



Continued from previous page.

| Warning Number:<br>Warning Name                             | Possible Cause   | Confirmation   | Correction  | Reference |
|---|--|--|---|-----------|
| 93Bh:<br>Overheat Warning                                   | The surrounding temperature is too high.   | Check the surrounding temperature using a thermometer.             | Lower the surrounding temperature by improving the installation conditions of the Linear Servomotor or the machine.   | –         |
|   | Operation was performed under an excessive load.   | Use the accumulated load ratio to check the load during operation. | Reconsider the load and operating conditions.   | –         |
|   | A failure occurred in the SERVOPACK.   | –  | The SERVOPACK may be faulty. Replace the SERVOPACK.   | –         |
|   | The temperature detection circuit in the Linear Servomotor is faulty or the sensor attached to the machine is faulty.                                  | –  | The temperature detection circuit in the Linear Servomotor may be faulty or the sensor attached to the machine may be faulty. Replace the Linear Servomotor or repair the sensor attached to the machine. | –         |
| 942h:<br>Speed Ripple Compensation Information Disagreement | The speed ripple compensation information stored in the encoder does not agree with the speed ripple compensation information stored in the SERVOPACK. | –  | Reset the speed ripple compensation value on the SigmaWin+.   | page 9-59 |
|   |  | –  | Set Pn423 (2423h) to n.□□1□ (Do not detect A.942 alarms). However, changing the setting may increase the speed ripple.  | page 9-59 |
|   |  | –  | Set Pn423 (2423h) to n.□□□0 (Disable speed ripple compensation). However, changing the setting may increase the speed ripple.   | page 9-59 |
| 971h:<br>Undervoltage                                       | For a 400-V SERVOPACK, the AC power supply voltage dropped below 280 V.  | Measure the power supply voltage.                                  | Set the power supply voltage within the specified range.  | –         |
|   | The power supply voltage dropped during operation.   | Measure the power supply voltage.                                  | Increase the power supply capacity.   | –         |
|   | A momentary power interruption occurred.   | Measure the power supply voltage.                                  | If you have changed the setting of Pn509 (2509h) (Momentary Power Interruption Hold Time), decrease the setting.  | page 7-18 |
|   | The SERVOPACK fuse is blown out.   | –  | Replace the SERVOPACK and connect a reactor.  | page 4-18 |
|   | A failure occurred in the SERVOPACK.   | –  | The SERVOPACK may be faulty. Replace the SERVOPACK.   | –         |

Continued on next page.

15.3 Warning Displays

15.3.2 Troubleshooting Warnings

Continued from previous page.

| Warning Number:<br>Warning Name                              | Possible Cause   | Confirmation  | Correction  | Reference  |
|--|--|---|---|------------|
| <b>9A0h:</b><br>Overtravel (Overtravel status was detected.) | Overtravel was detected while the servo was ON.                      | Check the status of the overtravel signals on the input signal monitor. | Even if an overtravel signal is not shown by the input signal monitor, momentary overtravel may have been detected. Take the following precautions. <ul style="list-style-type: none"> <li>• Do not specify movements that would cause overtravel from the host controller.</li> <li>• Check the wiring of the overtravel signals.</li> <li>• Implement countermeasures against noise.</li> </ul> | page 6-28  |
| <b>9b0h:</b><br>Preventative Maintenance Warning             | One of the consumable parts has reached the end of its service life. | -   | Replace the part. Contact your Yaskawa representative for replacement.  | page 10-15 |

# 15.4 Troubleshooting Based on the Operation and Conditions of the Servomotor

This section provides troubleshooting based on the operation and conditions of the Servomotor, including causes and corrections.

| Problem                              | Possible Cause  | Confirmation  | Correction   | Reference            |
|--------------------------------------|---|---|--|----------------------|
| Servomotor Does Not Start            | The control power supply is not turned ON.  | Measure the voltage between control power supply terminals.                                   | Turn OFF the Servo System. Correct the wiring so that the control power supply is turned ON.   | -                    |
|                                      | The main circuit power supply is not turned ON.   | Measure the voltage across the main circuit power input terminals.                            | Turn OFF the Servo System. Correct the wiring so that the main circuit power supply is turned ON.  | -                    |
|                                      | The I/O signal connector (CN1) pins are not wired correctly or are disconnected.  | Turn OFF the Servo System. Check the wiring condition of the I/O signal connector (CN1) pins. | Correct the wiring of the I/O signal connector (CN1) pins.   | page 4-36, page 10-5 |
|                                      | The wiring for the Servomotor Main Circuit Cables or Encoder Cable is disconnected.   | Check the wiring conditions.  | Turn OFF the Servo System. Wire the cable correctly.   | -                    |
|                                      | There is an overload on the Servomotor.   | Operate the Servomotor with no load and check the load status.                                | Turn OFF the Servo System. Reduce the load or replace the Servomotor with a Servomotor with a larger capacity.   | -                    |
|                                      | The type of encoder that is being used does not agree with the setting of Pn002 (2002h) = n.X□□ (Encoder Usage).                                    | Check the type of the encoder that is being used and the setting of Pn002 = n.X□□.            | Set Pn002 = n.X□□ according to the type of the encoder that is being used.   | page 7-28            |
|                                      | There is a mistake in the input signal allocations (Pn50A (250Ah), Pn50B (250Bh), Pn511 (2511h), Pn516 (2516h), or Pn590 (2590h) to Pn599 (2599h)). | Check the input signal allocations (Pn50A, Pn50B, Pn511, Pn516, and Pn590 to Pn599).          | Correctly allocate the input signals (Pn50A, Pn50B, Pn511, Pn516, and Pn590 to Pn599).   | page 7-3, page 10-5  |
|                                      | The Servo ON (Enable Operation) command was not sent.   | Check the commands sent from the host controller.   | Send the Servo ON (Enable Operation) command from the host controller.   | -                    |
|                                      | The P-OT (Forward Drive Prohibit) or N-OT (Reverse Drive Prohibit) signal is still OFF.   | Check the P-OT and N-OT signals.  | Turn ON the P-OT and N-OT signals.   | page 10-5            |
|                                      | The FSTP (Forced Stop Input) signal is still OFF.   | Check the FSTP signal.  | <ul style="list-style-type: none"> <li>Turn ON the FSTP signal.</li> <li>If you will not use the function to force the motor to stop, set Pn516 (2516h) = n.X□□ (FSTP (Forced Stop Input) Signal Allocation) to disable the signal.</li> </ul> | page 10-5            |
| A failure occurred in the SERVOPACK. | -   | Turn OFF the Servo System. Replace the SERVOPACK.   | -  |                      |

Continued on next page.

Continued from previous page.

| Problem  | Possible Cause   | Confirmation   | Correction   | Reference |
|--|--|--|--|-----------|
| Servomotor Does Not Start                        | The polarity detection was not executed.   | Check the setting of Pn080 (2080h) = n.□□□X (Polarity Sensor Selection).   | Correct the parameter setting.   | page 6-21 |
|  |  | Check the inputs to the Servo ON (Enable Operation) command.   | <ul style="list-style-type: none"> <li>If you are using an incremental linear encoder, send the Servo ON (Enable Operation) command from the host controller.</li> <li>If you are using an absolute linear encoder, execute polarity detection.</li> </ul> | page 6-22 |
| Servomotor Moves Instantaneously, and Then Stops | There is a mistake in the Servomotor wiring.   | Turn OFF the Servo System. Check the wiring.   | Wire the Servomotor correctly.   | -         |
|  | There is a mistake in the wiring of the encoder or Serial Converter Unit.  | Turn OFF the Servo System. Check the wiring.   | Wire the Serial Converter Unit correctly.  | -         |
|  | There is a mistake in the linear encoder wiring.   | Turn OFF the Servo System. Check the wiring.   | Wire the cable correctly.  | -         |
|  | The setting of Pn282 (2282h) (Linear Encoder Scale Pitch) is not correct.  | Check the setting of Pn282.  | Correct the setting of Pn282.  | page 6-14 |
|  | The count-up direction of the linear encoder does not match the forward direction of the Moving Coil in the motor.     | Check the directions.  | Change the setting of Pn080 (2080h) = n.□□X□ (Motor Phase Sequence Selection). Place the linear encoder and motor in the same direction.   | page 6-19 |
| Polarity detection was not performed correctly.  | Check to see if electrical angle 2 (electrical angle from polarity origin) at any position is between $\pm 10^\circ$ . | Correct the settings for the polarity detection-related parameters.  | -  |           |
| Servomotor Speed Is Unstable                     | There is a faulty connection in the Servomotor wiring.   | The connector connections for the power line (U, V, and W phases) and the encoder or Serial Converter Unit may be unstable. Turn OFF the Servo System. Check the wiring. | Tighten any loose terminals or connectors and correct the wiring.  | -         |
| Servomotor Moves without a Reference Input       | A failure occurred in the SERVOPACK.   | -  | Turn OFF the Servo System. Replace the SERVOPACK.  | -         |
|  | The count-up direction of the linear encoder does not match the forward direction of the Moving Coil in the motor.     | Check the directions.  | Change the setting of Pn080 (2080h) = n.□□X□ (Motor Phase Sequence Selection). Match the linear encoder direction and Servomotor direction.  | page 6-19 |
|  | Polarity detection was not performed correctly.  | Check to see if electrical angle 2 (electrical angle from polarity origin) at any position is between $\pm 10^\circ$ .   | Correct the settings for the polarity detection-related parameters.  | -         |

Continued on next page.

Continued from previous page.

| Problem                        | Possible Cause  | Confirmation   | Correction   | Reference |
|--------------------------------|---|--|--|-----------|
| Dynamic Brake Does Not Operate | The setting of Pn001 (2001h) = n.□□□X (Motor Stopping Method for Servo OFF and Group 1 Alarms) is not suitable. | Check the setting of Pn001 = n.□□□X.   | Set Pn001 = n.□□□X correctly.  | -         |
|                                | The Dynamic Brake Resistor is disconnected.   | Check the moment of inertia, motor speed, and dynamic brake frequency of use. If the moment of inertia, motor speed, or dynamic brake frequency of use is excessive, the dynamic brake resistance may be disconnected. | Turn OFF the Servo System. Replace the SERVOPACK. To prevent disconnection, reduce the load.                   | -         |
|                                | There was a failure in the dynamic brake drive circuit.   | -  | There is a defective component in the dynamic brake circuit. Turn OFF the Servo System. Replace the SERVOPACK. | -         |

Continued on next page.

Continued from previous page.

| Problem  | Possible Cause   | Confirmation   | Correction  | Reference |
|--|--|--|---|-----------|
| Abnormal Noise from Servomotor   | The Servomotor vibrated considerably while performing the tuning-less function with the default settings.  | Check the waveform of the motor speed.   | Reduce the load so that the moment of inertia ratio or mass ratio is within the allowable value, or increase the load level or reduce the rigidity level in the tuning-less level settings. | page 9-12 |
|  | The machine mounting is not secure.  | Turn OFF the Servo System. Check to see if there are any loose mounting screws.  | Tighten the mounting screws.  | -         |
|  | The machine mounting is not secure.  | Turn OFF the Servo System. Check to see if there is misalignment in the coupling.  | Align the coupling.   | -         |
|  |  | Turn OFF the Servo System. Check to see if the coupling is balanced.   | Balance the coupling.   | -         |
|  | The bearings are defective.  | Turn OFF the Servo System. Check for noise and vibration around the bearings.  | Replace the Servomotor.   | -         |
|  | There is a vibration source at the driven machine.   | Turn OFF the Servo System. Check for any foreign matter, damage, or deformation in the machine's moving parts.   | Consult with the machine manufacturer.  | -         |
|  | Noise interference occurred because of incorrect I/O signal cable specifications.  | Turn OFF the Servo System. Check the I/O signal cables to see if they satisfy specifications. Use shielded twisted-pair cables or screened twisted-pair cables with conductors of at least 0.12 mm <sup>2</sup> (stranded wire). | Use cables that satisfy the specifications.   | -         |
|  | Noise interference occurred because an I/O signal cable is too long.   | Turn OFF the Servo System. Check the lengths of the I/O signal cables.   | The I/O signal cables must be no longer than 3 m.   | -         |
| Noise interference occurred because of incorrect Encoder Cable specifications. | Turn OFF the Servo System. Check the Encoder Cable to see if it satisfies specifications. Use shielded twisted-pair cables or screened twisted-pair cables with conductors of at least 0.12 mm <sup>2</sup> (stranded wire). | Use cables that satisfy the specifications.  | -   |           |

Continued on next page.

Continued from previous page.

| Problem                        | Possible Cause  | Confirmation   | Correction   | Reference |
|--------------------------------|---|--|--|-----------|
| Abnormal Noise from Servomotor | Noise interference occurred because the Encoder Cable is too long.  | Turn OFF the Servo System. Check the length of the Encoder Cable.  | <ul style="list-style-type: none"> <li>Rotary Servomotors: The Encoder Cable length must be 50 m max.</li> <li>Linear Servomotors: Make sure that the Serial Converter Unit cable is no longer than 20 m and that the Linear Encoder Cable and the Sensor Cable are no longer than 15 m each.</li> </ul> | -         |
|                                | Noise interference occurred because the Encoder Cable is damaged.   | Turn OFF the Servo System. Check the Encoder Cable to see if it is pinched or the sheath is damaged.   | Replace the Encoder Cable and correct the cable installation environment.  | -         |
|                                | The Encoder Cable was subjected to excessive noise interference.  | Turn OFF the Servo System. Check to see if the Encoder Cable is bundled with a high-current line or installed near a high-current line.  | Correct the cable layout so that no surge is applied by high-current lines.  | -         |
|                                | There is variation in the FG potential because of the influence of machines on the Servomotor side, such as a welder. | Turn OFF the Servo System. Check to see if the machines are correctly grounded.  | Properly ground the machines to separate them from the FG of the encoder.  | -         |
|                                | There is a SERVOPACK pulse counting error due to noise.   | Check to see if there is noise interference on the signal line from the encoder.   | Turn OFF the Servo System. Implement countermeasures against noise for the encoder wiring.   | -         |
|                                | The encoder was subjected to excessive vibration or shock.  | Turn OFF the Servo System. Check to see if vibration from the machine occurred. Check the Servomotor installation (mounting surface precision, securing state, and alignment). Check the linear encoder installation (mounting surface precision and securing method). | Reduce machine vibration. Improve the mounting state of the Servomotor or linear encoder.  | -         |
|                                | A failure occurred in the encoder.  | -  | Turn OFF the Servo System. Replace the Servomotor.   | -         |
|                                | A failure occurred in the Serial Converter Unit.  | -  | Turn OFF the Servo System. Replace the Serial Converter Unit.  | -         |
|                                | A failure occurred in the linear encoder.   | -  | Turn OFF the Servo System. Replace the linear encoder.   | -         |

Continued on next page.

Continued from previous page.

| Problem  | Possible Cause   | Confirmation  | Correction                                   | Reference |
|--|--|---|--|-----------|
| Servomotor Vibrates at Frequency of Approx. 200 to 400 Hz. | The servo gains are not balanced.  | Check to see if the servo gains have been correctly tuned.              | Perform autotuning without a host reference. | page 9-24 |
|  | The setting of Pn100 (2100h) (Speed Loop Gain) is too high.                              | Check the setting of Pn100. The default setting is Kv = 40.0 Hz.        | Set Pn100 to an appropriate value.           | -         |
|  | The setting of Pn102 (2102h) (Position Loop Gain) is too high.                           | Check the setting of Pn102. The default setting is Kp = 40.0/s.         | Set Pn102 to an appropriate value.           | -         |
|  | The setting of Pn101 (2101h) (Speed Loop Integral Time Constant) is not appropriate.     | Check the setting of Pn101. The default setting is Ti = 20.0 ms.        | Set Pn101 to an appropriate value.           | -         |
|  | The setting of Pn103 (2103h) (Moment of Inertia Ratio or Mass Ratio) is not appropriate. | Check the setting of Pn103.   | Set Pn103 to an appropriate value.           | -         |
| Large Motor Speed Overshoot on Starting and Stopping       | The servo gains are not balanced.  | Check to see if the servo gains have been correctly tuned.              | Perform autotuning without a host reference. | page 9-24 |
|  | The setting of Pn100 (2100h) (Speed Loop Gain) is too high.                              | Check the setting of Pn100. The default setting is Kv = 40.0 Hz.        | Set Pn100 to an appropriate value.           | -         |
|  | The setting of Pn102 (2102h) (Position Loop Gain) is too high.                           | Check the setting of Pn102. The default setting is Kp = 40.0/s.         | Set Pn102 to an appropriate value.           | -         |
|  | The setting of Pn101 (2101h) (Speed Loop Integral Time Constant) is not appropriate.     | Check the setting of Pn101. The default setting is Ti = 20.0 ms.        | Set Pn101 to an appropriate value.           | -         |
|  | The setting of Pn103 (2103h) (Moment of Inertia Ratio or Mass Ratio) is not appropriate. | Check the setting of Pn103.   | Set Pn103 to an appropriate value.           | -         |
|  | The torque reference is saturated.   | Check the waveform of the torque reference.                             | Use the mode switch.                         | -         |
|  | The force limits (Pn483 (2483h) and Pn484 (2484h)) are set to the default values.        | The default values of the force limits are Pn483 = 30% and Pn484 = 30%. | Set Pn483 and Pn484 to appropriate values.   | page 7-23 |

Continued on next page.



Continued from previous page.

| Problem  | Possible Cause  | Confirmation   | Correction   | Reference |
|--|---|--|--|-----------|
| Absolute Encoder Position Deviation Error (The position that was saved in the host controller when the power was turned OFF is different from the position when the power was next turned ON.) | Noise interference occurred because of incorrect Encoder Cable specifications.  | Turn OFF the Servo System. Check the Encoder Cable to see if it satisfies specifications. Use shielded twisted-pair cables or screened twisted-pair cables with conductors of at least 0.12 mm <sup>2</sup> (stranded wire).   | Use cables that satisfy the specifications.  | -         |
|  | Noise interference occurred because the Encoder Cable is too long.  | Turn OFF the Servo System. Check the length of the Encoder Cable.  | <ul style="list-style-type: none"> <li>Rotary Servomotors: The Encoder Cable length must be 50 m max.</li> <li>Linear Servomotors: Make sure that the Serial Converter Unit cable is no longer than 20 m and that the Linear Encoder Cable and the Sensor Cable are no longer than 15 m each.</li> </ul> | -         |
|  | Noise interference occurred because the Encoder Cable is damaged.   | Turn OFF the Servo System. Check the Encoder Cable to see if it is pinched or the sheath is damaged.   | Replace the Encoder Cable and correct the cable installation environment.  | -         |
|  | The Encoder Cable was subject to excessive noise interference.  | Turn OFF the Servo System. Check to see if the Encoder Cable is bundled with a high-current line or installed near a high-current line.  | Correct the cable layout so that no surge is applied by high-current lines.  | -         |
|  | There is variation in the FG potential because of the influence of machines on the Servomotor side, such as a welder. | Turn OFF the Servo System. Check to see if the machines are correctly grounded.  | Properly ground the machines to separate them from the FG of the encoder.  | -         |
|  | There is a SERVOPACK pulse counting error due to noise.   | Turn OFF the Servo System. Check to see if there is noise interference on the I/O signal line from the encoder or Serial Converter Unit.   | Implement countermeasures against noise for the encoder or Serial Converter Unit wiring.   | -         |
|  | The encoder was subjected to excessive vibration or shock.  | Turn OFF the Servo System. Check to see if vibration from the machine occurred. Check the Servomotor installation (mounting surface precision, securing state, and alignment). Check the linear encoder installation (mounting surface precision and securing method). | Reduce machine vibration. Improve the mounting state of the Servomotor or linear encoder.  | -         |
|  | A failure occurred in the encoder.  | -  | Turn OFF the Servo System. Replace the Servomotor or linear encoder.   | -         |
|  | A failure occurred in the SERVOPACK.  | -  | Turn OFF the Servo System. Replace the SERVOPACK.  | -         |

Continued on next page.

Continued from previous page.

| Problem  | Possible Cause   | Confirmation  | Correction   | Reference |
|--|--|---|--|-----------|
| Absolute Encoder Position Deviation Error (The position that was saved in the host controller when the power was turned OFF is different from the position when the power was next turned ON.) | Host controller multiturn data or absolute encoder position data reading error | Check the error detection section of the host controller.                                 | Correct the error detection section of the host controller.  | -         |
|  |  | Check to see if the host controller is executing data parity checks.                      | Perform parity checks for the multiturn data or absolute encoder position data.  | -         |
|  |  | Check for noise interference in the cable between the SERVO-PACK and the host controller. | Implement countermeasures against noise and then perform parity checks again for the multiturn data or absolute encoder position data. | -         |

Continued on next page.

Continued from previous page.

| Problem   | Possible Cause  | Confirmation   | Correction  | Reference |
|---|---|--|---|-----------|
| Overtravel Occurred   | The P-OT/N-OT (Forward Drive Prohibit or Reverse Drive Prohibit) signal was input.  | Check the external power supply (+24 V) voltage for the input signals.   | Correct the external power supply (+24 V) voltage for the input signals.                    | -         |
|   |   | Check the operating condition of the overtravel limit switches.  | Make sure that the overtravel limit switches operate correctly.                             | -         |
|   |   | Check the wiring of the overtravel limit switches.   | Correct the wiring of the overtravel limit switches.  | page 6-25 |
|   |   | Check the settings of the overtravel input signal allocations (Pn50A (250Ah) and Pn50B (250Bh), or Pn590 (2590h) and Pn591 (2591h)). | Set the parameters to correct values.   | page 6-25 |
|   | The P-OT/N-OT (Forward Drive Prohibit or Reverse Drive Prohibit) signal malfunctioned.  | Check for fluctuation in the external power supply (+24 V) voltage for the input signals.  | Eliminate fluctuation from the external power supply (+24 V) voltage for the input signals. | -         |
|   |   | Check to see if the operation of the overtravel limit switches is unstable.  | Stabilize the operating condition of the overtravel limit switches.                         | -         |
|   |   | Check the wiring of the overtravel limit switches (e.g., check for cable damage and loose screws).                                   | Correct the wiring of the overtravel limit switches.  | -         |
|   | There is a mistake in the allocation of the P-OT or N-OT (Forward Drive Prohibit or Reverse Drive Prohibit) signal in Pn50A (250Ah) = n.X□□□ or Pn50B (250Bh) = n.□□□X. | Check to see if the P-OT signal is allocated in Pn50A = n.X□□□.  | If another signal is allocated in Pn50A = n.X□□□, allocate the P-OT signal instead.         | page 6-25 |
|   |   | Check to see if the N-OT signal is allocated in Pn50B = n.□□□X.  | If another signal is allocated in Pn50B = n.□□□X, allocate the N-OT signal instead.         |           |
|   | The selection of the Servomotor stopping method is not correct.   | Check the servo OFF stopping method set in Pn001 (2001h) = n.□□□X or Pn001 (2001h) = n.□□X□.   | Select a Servomotor stopping method other than coasting to a stop.                          | page 6-26 |
| Check the torque control stopping method set in Pn001 (2001h) = n.□□□X or Pn001 (2001h) = n.□□X□. |   | Select a Servomotor stopping method other than coasting to a stop.   |   |           |
| Improper Stop Position for Overtravel (OT) Signal   | The limit switch position and dog length are not appropriate.   | -  | Install the limit switch at the appropriate position.                                       | -         |
|   | The overtravel limit switch position is too close for the coasting distance.  | -  | Install the overtravel limit switch at the appropriate position.                            | -         |

Continued on next page.

Continued from previous page.

| Problem                            | Possible Cause  | Confirmation   | Correction   | Reference |
|------------------------------------|---|--|--|-----------|
| Position Deviation (without Alarm) | Noise interference occurred because of incorrect Encoder Cable specifications.  | Turn OFF the Servo System. Check the Encoder Cable to see if it satisfies specifications. Use shielded twisted-pair cables or screened twisted-pair cables with conductors of at least 0.12 mm <sup>2</sup> (stranded wire).   | Use cables that satisfy the specifications.  | -         |
|                                    | Noise interference occurred because the Encoder Cable is too long.  | Turn OFF the Servo System. Check the length of the Encoder Cable.  | <ul style="list-style-type: none"> <li>Rotary Servomotors: The Encoder Cable length must be 50 m max.</li> <li>Linear Servomotors: Make sure that the Serial Converter Unit cable is no longer than 20 m and that the Linear Encoder Cable and the Sensor Cable are no longer than 15 m each.</li> </ul> | -         |
|                                    | Noise interference occurred because the Encoder Cable is damaged.   | Turn OFF the Servo System. Check the Encoder Cable to see if it is pinched or the sheath is damaged.   | Replace the Encoder Cable and correct the cable installation environment.  | -         |
|                                    | The Encoder Cable was subjected to excessive noise interference.  | Turn OFF the Servo System. Check to see if the Encoder Cable is bundled with a high-current line or installed near a high-current line.  | Correct the cable layout so that no surge is applied by high-current lines.  | -         |
|                                    | There is variation in the FG potential because of the influence of machines on the Servomotor side, such as a welder. | Turn OFF the Servo System. Check to see if the machines are correctly grounded.  | Properly ground the machines to separate them from the FG of the encoder.  | -         |
|                                    | There is a SERVOPACK pulse counting error due to noise.   | Turn OFF the Servo System. Check to see if there is noise interference on the I/O signal line from the encoder or Serial Converter Unit.   | Implement countermeasures against noise for the encoder wiring or Serial Converter Unit wiring.  | -         |
|                                    | The encoder was subjected to excessive vibration or shock.  | Turn OFF the Servo System. Check to see if vibration from the machine occurred. Check the Servomotor installation (mounting surface precision, securing state, and alignment). Check the linear encoder installation (mounting surface precision and securing method). | Reduce machine vibration. Improve the mounting state of the Servomotor or linear encoder.  | -         |
|                                    | The coupling between the machine and Servomotor is not suitable.  | Turn OFF the Servo System. Check to see if position offset occurs at the coupling between machine and Servomotor.  | Correctly secure the coupling between the machine and Servomotor.  | -         |

Continued on next page.

Continued from previous page.

| Problem                            | Possible Cause  | Confirmation   | Correction  | Reference |
|------------------------------------|---|--|---|-----------|
| Position Deviation (without Alarm) | Noise interference occurred because of incorrect I/O Signal Cable specifications. | Turn OFF the Servo System. Check the I/O Signal Cables to see if they satisfy specifications. Use shielded twisted-pair cables or screened twisted-pair cables with conductors of at least 0.12 mm <sup>2</sup> (stranded wire). | Use cables that satisfy the specifications.   | -         |
|                                    | Noise interference occurred because an I/O Signal Cable is too long.              | Turn OFF the Servo System. Check the lengths of the I/O Signal Cables.   | The I/O Signal Cables must be no longer than 3 m.   | -         |
|                                    | An encoder fault occurred. (The pulse count does not change.)                     | -  | Turn OFF the Servo System. Replace the Servomotor or linear encoder.  | -         |
|                                    | A failure occurred in the SERVOPACK.  | -  | Turn OFF the Servo System. Replace the SERVOPACK.   | -         |
| Servomotor Overheated              | The surrounding air temperature is too high.                                      | Measure the surrounding air temperature around the Servomotor.   | Reduce the surrounding air temperature to 40°C or less.   | -         |
|                                    | The surface of the Servomotor is dirty.   | Turn OFF the Servo System. Visually check the surface for dirt.  | Clean dirt, dust, and oil from the surface.   | -         |
|                                    | There is an overload on the Servomotor.   | Check the load status with a monitor.  | If the Servomotor is overloaded, reduce the load or replace the Servo Drive with a SERVOPACK and Servomotor with larger capacities. | -         |
|                                    | Polarity detection was not performed correctly.                                   | Check to see if electrical angle 2 (electrical angle from polarity origin) at any position is between ±10°.  | Correct the settings for the polarity detection-related parameters.   | -         |



# Parameter and Object Lists

---

# 16

This chapter provides information on parameters and objects.

|             |  |              |
|-------------|--|--------------|
| <b>16.1</b> | <b>List of Servo Parameters . . . . .</b>  | <b>16-2</b>  |
| 16.1.1      | Interpreting the Parameter Lists . . . . . | 16-2         |
| 16.1.2      | List of Parameters . . . . .               | 16-3         |
| <b>16.2</b> | <b>Object List . . . . .</b>               | <b>16-39</b> |
| <b>16.3</b> | <b>SDO Abort Code List . . . . .</b>       | <b>16-53</b> |
| <b>16.4</b> | <b>Parameter Recording Table . . . . .</b> | <b>16-54</b> |

# 16.1 List of Servo Parameters

## 16.1.1 Interpreting the Parameter Lists

The types of motors to which the parameter applies.

- All: The parameter is used for both Rotary Servomotors and Linear Servomotors.
- Rotary: The parameter is used for only Rotary Servomotors.
- Linear: The parameter is used for only Linear Servomotors.

Rotary Servomotor terms are used for parameters that are applicable to all Servomotors. If you are using a Linear Servomotor, you need to interpret the terms accordingly. Refer to the following section for details.

◆ Differences in Terms for Rotary Servomotors and Linear Servomotors on page vi

“After restart” indicates parameters that will be effective after one of the following is executed.

- The power supply is turned OFF and ON again.
- A software reset is executed.

| Parameter No.                                  | Size   | Name   | Setting Range   | Setting Unit | Default Setting | Applicable Motors | When Enabled  | Classification | Reference |           |
|--|--------|--|---|--------------|-----------------|-------------------|---------------|----------------|-----------|-----------|
|  | 2      | Basic Function Selections 0  | 0000h to 10B1h  | -            | 0000h           | All               | After restart | Setup          | -         |           |
| Pn000<br>(A: 2000h,<br>B: 2800h)<br><br>Common | n.□□□X | Rotation Direction Selection   |   |              |                 |                   |               |                |           |           |
|  |        | Movement Direction Selection   |   |              |                 |                   |               |                |           |           |
|  |        | 0  | Use CCW as the forward direction.   |              |                 |                   |               |                |           | page 6-13 |
|  |        |  | Use the direction in which the linear encoder counts up as the forward direction.                           |              |                 |                   |               |                |           |           |
|  |        | 1  | Use CW as the forward direction. (Reverse Rotation Mode)  |              |                 |                   |               |                |           |           |
|  |        |  | Use the direction in which the linear encoder counts down as the forward direction. (Reverse Movement Mode) |              |                 |                   |               |                |           |           |
|  |        | n.X□□□   |   |              |                 |                   |               |                |           |           |
|  |        | Rotary/Linear Servomotor Startup Selection When Encoder Is Not Connected |   |              |                 |                   |               |                |           |           |
|  |        | 0  | When an encoder is not connected, start as SERVOPACK for Rotary Servomotor.                                 |              |                 |                   |               |                |           | page 6-12 |
|  |        | 1  | When an encoder is not connected, start as SERVOPACK for Linear Servomotor.                                 |              |                 |                   |               |                |           |           |

If there are differences in the parameters for Rotary Servomotor and Linear Servomotor, information is provided for both.

- Top row: For Rotary Servomotors
- Bottom row: For Linear Servomotors

There are the following two classifications.

- Setup
- Tuning

Refer to the following section for details.

6.1.1 Classifications of SERVOPACK Parameters on page 6-3

The numbers shown in parentheses are the index numbers of EtherCAT objects. These numbers are the index numbers assigned to each axis (axis A and axis B) or the index number common to both axes.

If **Common** is given here, the parameter applies to both axes A and B. If you change the setting, the new setting will be applied to both axes.



## 16.1.2 List of Parameters

The following table lists the parameters.

Note: Do not change the following parameters from their default settings.

- Reserved parameters
- Parameters not given in this manual
- Parameters that are not valid for the Servomotor that you are using, as given in the parameter table

| Parameter No.                    | Size   | Name  | Setting Range   | Setting Unit | Default Setting | Applicable Motors | When Enabled  | Classification | Reference |  |
|----------------------------------|--------|---|---|--------------|-----------------|-------------------|---------------|----------------|-----------|--|
| Pn000<br>(A: 2000h,<br>B: 2800h) | 2      | Basic Function Selections 0   | 0000h to 10B1h  | –            | 0000h           | All               | After restart | Setup          | –         |  |
|                                  |        | n.□□□X  | Rotation Direction Selection  |              |                 |                   |               | Reference      |           |  |
|                                  |        |   | Movement Direction Selection  |              |                 |                   |               |                |           |  |
|                                  |        | 0   | Use CCW as the forward direction.   |              |                 |                   |               | page 6-13      |           |  |
|                                  |        |   | Use the direction in which the linear encoder counts up as the forward direction.                                 |              |                 |                   |               |                |           |  |
|                                  |        | 1   | Use CW as the forward direction. (Reverse Rotation Mode)  |              |                 |                   |               |                |           |  |
|                                  |        |   | Use the direction in which the linear encoder counts down as the forward direction. (Reverse Movement Mode)       |              |                 |                   |               |                |           |  |
|                                  |        | n.□□X□  | Reserved parameter (Do not change.)   |              |                 |                   |               |                |           |  |
|                                  |        | n.□X□□  | Reserved parameter (Do not change.)   |              |                 |                   |               |                |           |  |
|                                  |        | n.X□□□  | Rotary/Linear Servomotor Startup Selection When Encoder Is Not Connected  |              |                 |                   |               | Reference      |           |  |
|                                  |        | 0   | When an encoder is not connected, start as SERVOPACK for Rotary Servomotor.                                       |              |                 |                   |               | page 6-12      |           |  |
|                                  |        | 1   | When an encoder is not connected, start as SERVOPACK for Linear Servomotor.                                       |              |                 |                   |               |                |           |  |
| Pn001<br>(A: 2001h,<br>B: 2801h) | 2      | Application Function Selections 1   | 0000h to 1142h  | –            | 0000h           | All               | After restart | Setup          | –         |  |
|                                  |        | n.□□□X  | Motor Stopping Method for Servo OFF and Group 1 Alarms  |              |                 |                   |               | Reference      |           |  |
|                                  |        | 0   | Stop the motor by applying the dynamic brake.   |              |                 |                   |               | page 6-36      |           |  |
|                                  |        | 1   | Stop the motor by the applying dynamic brake and then release the dynamic brake.                                  |              |                 |                   |               |                |           |  |
|                                  |        | 2   | Coast the motor to a stop without the dynamic brake.  |              |                 |                   |               |                |           |  |
|                                  |        | n.□□X□  | Overtravel Stopping Method  |              |                 |                   |               | Reference      |           |  |
|                                  |        | 0   | Apply the dynamic brake or coast the motor to a stop.   |              |                 |                   |               | page 6-26      |           |  |
|                                  |        | 1   | Decelerate the motor to a stop using the torque set in Pn406 as the maximum torque and then servo-lock the motor. |              |                 |                   |               |                |           |  |
|                                  |        | 2   | Decelerate the motor to a stop using the torque set in Pn406 as the maximum torque and then let the motor coast.  |              |                 |                   |               |                |           |  |
|                                  |        | 3   | Decelerate the motor to a stop using the deceleration time set in Pn30A and then servo-lock the motor.            |              |                 |                   |               |                |           |  |
|                                  |        | 4   | Decelerate the motor to a stop using the deceleration time set in Pn30A and then let the motor coast.             |              |                 |                   |               |                |           |  |
|                                  |        | n.□X□□  | Main Circuit Power Supply AC/DC Input Selection   |              |                 |                   |               | Reference      |           |  |
|                                  | 0      | Input AC power as the main circuit power supply using the L1, L2, and L3 terminals (do not use shared converter).                   |   |              |                 |                   | page 6-11     |                |           |  |
|                                  | 1      | Input DC power as the main circuit power supply using the B1 and ⊕ 2 terminals (use an external converter or the shared converter). |   |              |                 |                   |               |                |           |  |
|                                  | n.X□□□ | Reserved parameter (Do not change.)   |   |              |                 |                   |               |                |           |  |

Continued on next page.

16.1 List of Servo Parameters

16.1.2 List of Parameters

Continued from previous page.

| Parameter No.                    | Size   | Name                              | Setting Range  | Setting Unit  | Default Setting | Applicable Motors | When Enabled      | Classification | Reference |  |
|----------------------------------|--------|-----------------------------------|--|---|-----------------|-------------------|-------------------|----------------|-----------|--|
| Pn002<br>(A: 2002h,<br>B: 2802h) | 2      | Application Function Selections 2 | 0000h to 4213h   | -   | 0001h           | -                 | After restart     | Setup          | -         |  |
|                                  | n.□□□X |                                   | EtherCAT (CoE) Module Torque Limit Command Usage Selection |   |                 |                   | Applicable Motors | Reference      |           |  |
|                                  |        |                                   | 0  | Reserved parameter (Do not change.)   |                 |                   | All               | -              |           |  |
|                                  |        |                                   | 1  | Enable torque limit commands from EtherCAT (CoE). (Automatically set by the EtherCAT (CoE) Module.) |                 |                   |                   |                |           |  |
|                                  |        |                                   | 2  | Reserved parameter (Do not change.)   |                 |                   |                   |                |           |  |
|                                  |        |                                   | 3  | Reserved parameter (Do not change.)   |                 |                   |                   |                |           |  |
|                                  | n.□□X□ |                                   | EtherCAT (CoE) Module Speed Limit Command Usage Selection  |   |                 |                   | Applicable Motors | Reference      |           |  |
|                                  |        |                                   | 0  | Disable speed limit commands from EtherCAT (CoE) during torque control.                             |                 |                   | All               | -              |           |  |
|                                  |        |                                   | 1  | Reserved parameter (Do not change.)   |                 |                   |                   |                |           |  |
|                                  | n.□X□□ |                                   | Encoder Usage  |   |                 |                   | Applicable Motors | Reference      |           |  |
|                                  |        |                                   | 0  | Use the encoder as an absolute encoder.   |                 |                   | All               | page 7-28      |           |  |
|                                  |        |                                   | 1  | Use the encoder as an incremental encoder.  |                 |                   |                   |                |           |  |
|                                  |        |                                   | 2  | Use the encoder as a single-turn absolute encoder.  |                 |                   | Rotary            |                |           |  |
|                                  | n.X□□□ |                                   | Reserved parameter (Do not change.)                        |   |                 |                   |                   |                |           |  |

Continued on next page.

Continued from previous page.

| Parameter No.              | Size                                | Name   | Setting Range  | Setting Unit | Default Setting | Applicable Motors | When Enabled | Classification | Reference |                                   |  |    |  |                              |    |  |                                  |    |  |  |    |  |    |  |   |    |   |   |    |                                     |    |   |    |   |    |  |                                    |    |  |  |    |  |    |  |    |                                     |    |                                     |    |                                     |    |                         |          |                                      |        |                                     |  |        |                       |  |   |                     |   |                     |
|----------------------------|-------------------------------------|--|----------------|--------------|-----------------|-------------------|--------------|----------------|-----------|-----------------------------------|--|----|--|------------------------------|----|--|----------------------------------|----|--|--|----|--|----|--|---|----|---|---|----|-------------------------------------|----|---|----|---|----|--|------------------------------------|----|--|--|----|--|----|--|----|-------------------------------------|----|-------------------------------------|----|-------------------------------------|----|-------------------------|----------|--------------------------------------|--------|-------------------------------------|--|--------|-----------------------|--|---|---------------------|---|---------------------|
| Pn006<br>(2006h)<br>Common | 2                                   | Application Function Selections 6  | 0000h to 105Fh | –            | 0002h           | All               | Immediately  | Setup          | page 10-9 |                                   |  |    |  |                              |    |  |                                  |    |  |  |    |  |    |  |   |    |   |   |    |                                     |    |   |    |   |    |  |                                    |    |  |  |    |  |    |  |    |                                     |    |                                     |    |                                     |    |                         |          |                                      |        |                                     |  |        |                       |  |   |                     |   |                     |
|                            |                                     | <table border="1"> <thead> <tr> <th colspan="2">Analog Monitor 1 Signal Selection</th> </tr> </thead> <tbody> <tr> <td rowspan="2">00</td> <td>Motor speed (1 V/1,000 min<sup>-1</sup>)</td> </tr> <tr> <td>Motor speed (1 V/1,000 mm/s)</td> </tr> <tr> <td rowspan="2">01</td> <td>Speed reference (1 V/1,000 min<sup>-1</sup>)</td> </tr> <tr> <td>Speed reference (1 V/1,000 mm/s)</td> </tr> <tr> <td rowspan="2">02</td> <td>Torque reference (1 V/100% rated torque)</td> </tr> <tr> <td>Force reference (1 V/100% rated force)</td> </tr> <tr> <td>03</td> <td>Position deviation (0.05 V/reference unit)</td> </tr> <tr> <td rowspan="2">04</td> <td>Position amplifier deviation (after electronic gear) (0.05 V/encoder pulse unit)</td> </tr> <tr> <td>Position amplifier deviation (after electronic gear) (0.05 V/linear encoder pulse unit)</td> </tr> <tr> <td rowspan="2">05</td> <td>Position reference speed (1 V/1,000 min<sup>-1</sup>)</td> </tr> <tr> <td>Position reference speed (1 V/1,000 mm/s)</td> </tr> <tr> <td>06</td> <td>Reserved parameter (Do not change.)</td> </tr> <tr> <td>07</td> <td>Load-motor position deviation (0.01 V/reference unit)</td> </tr> <tr> <td>08</td> <td>Positioning completion (positioning completed: 5 V, positioning not completed: 0 V)</td> </tr> <tr> <td rowspan="2">09</td> <td>Speed feedforward (1 V/1,000 min<sup>-1</sup>)</td> </tr> <tr> <td>Speed feedforward (1 V/1,000 mm/s)</td> </tr> <tr> <td rowspan="2">0A</td> <td>Torque feedforward (1 V/100% rated torque)</td> </tr> <tr> <td>Force feedforward (1 V/100% rated force)</td> </tr> <tr> <td>0B</td> <td>Active gain (1st gain: 1 V, 2nd gain: 2 V)</td> </tr> <tr> <td>0C</td> <td>Completion of position reference distribution (completed: 5 V, not completed: 0 V)</td> </tr> <tr> <td>0D</td> <td>Reserved parameter (Do not change.)</td> </tr> <tr> <td>0E</td> <td>Reserved parameter (Do not change.)</td> </tr> <tr> <td>0F</td> <td>Reserved parameter (Do not change.)</td> </tr> <tr> <td>10</td> <td>Main circuit DC voltage</td> </tr> <tr> <td>11 to 5F</td> <td>Reserved parameters (Do not change.)</td> </tr> <tr> <td>n.□□□□</td> <td colspan="2">Reserved parameter (Do not change.)</td> </tr> <tr> <td rowspan="3">n.X□□□</td> <th colspan="2">Output Axis Selection</th> </tr> <tr> <td>0</td> <td>Output axis A data.</td> </tr> <tr> <td>1</td> <td>Output axis B data.</td> </tr> </tbody> </table> |                |              |                 |                   |              |                |           | Analog Monitor 1 Signal Selection |  | 00 | Motor speed (1 V/1,000 min <sup>-1</sup> ) | Motor speed (1 V/1,000 mm/s) | 01 | Speed reference (1 V/1,000 min <sup>-1</sup> ) | Speed reference (1 V/1,000 mm/s) | 02 | Torque reference (1 V/100% rated torque) | Force reference (1 V/100% rated force) | 03 | Position deviation (0.05 V/reference unit) | 04 | Position amplifier deviation (after electronic gear) (0.05 V/encoder pulse unit) | Position amplifier deviation (after electronic gear) (0.05 V/linear encoder pulse unit) | 05 | Position reference speed (1 V/1,000 min <sup>-1</sup> ) | Position reference speed (1 V/1,000 mm/s) | 06 | Reserved parameter (Do not change.) | 07 | Load-motor position deviation (0.01 V/reference unit) | 08 | Positioning completion (positioning completed: 5 V, positioning not completed: 0 V) | 09 | Speed feedforward (1 V/1,000 min <sup>-1</sup> ) | Speed feedforward (1 V/1,000 mm/s) | 0A | Torque feedforward (1 V/100% rated torque) | Force feedforward (1 V/100% rated force) | 0B | Active gain (1st gain: 1 V, 2nd gain: 2 V) | 0C | Completion of position reference distribution (completed: 5 V, not completed: 0 V) | 0D | Reserved parameter (Do not change.) | 0E | Reserved parameter (Do not change.) | 0F | Reserved parameter (Do not change.) | 10 | Main circuit DC voltage | 11 to 5F | Reserved parameters (Do not change.) | n.□□□□ | Reserved parameter (Do not change.) |  | n.X□□□ | Output Axis Selection |  | 0 | Output axis A data. | 1 | Output axis B data. |
|                            | Analog Monitor 1 Signal Selection   |  |                |              |                 |                   |              |                |           |                                   |  |    |  |                              |    |  |                                  |    |  |  |    |  |    |  |   |    |   |   |    |                                     |    |   |    |   |    |  |                                    |    |  |  |    |  |    |  |    |                                     |    |                                     |    |                                     |    |                         |          |                                      |        |                                     |  |        |                       |  |   |                     |   |                     |
|                            | 00                                  | Motor speed (1 V/1,000 min <sup>-1</sup> )   |                |              |                 |                   |              |                |           |                                   |  |    |  |                              |    |  |                                  |    |  |  |    |  |    |  |   |    |   |   |    |                                     |    |   |    |   |    |  |                                    |    |  |  |    |  |    |  |    |                                     |    |                                     |    |                                     |    |                         |          |                                      |        |                                     |  |        |                       |  |   |                     |   |                     |
|                            |                                     | Motor speed (1 V/1,000 mm/s)   |                |              |                 |                   |              |                |           |                                   |  |    |  |                              |    |  |                                  |    |  |  |    |  |    |  |   |    |   |   |    |                                     |    |   |    |   |    |  |                                    |    |  |  |    |  |    |  |    |                                     |    |                                     |    |                                     |    |                         |          |                                      |        |                                     |  |        |                       |  |   |                     |   |                     |
|                            | 01                                  | Speed reference (1 V/1,000 min <sup>-1</sup> )   |                |              |                 |                   |              |                |           |                                   |  |    |  |                              |    |  |                                  |    |  |  |    |  |    |  |   |    |   |   |    |                                     |    |   |    |   |    |  |                                    |    |  |  |    |  |    |  |    |                                     |    |                                     |    |                                     |    |                         |          |                                      |        |                                     |  |        |                       |  |   |                     |   |                     |
|                            |                                     | Speed reference (1 V/1,000 mm/s)   |                |              |                 |                   |              |                |           |                                   |  |    |  |                              |    |  |                                  |    |  |  |    |  |    |  |   |    |   |   |    |                                     |    |   |    |   |    |  |                                    |    |  |  |    |  |    |  |    |                                     |    |                                     |    |                                     |    |                         |          |                                      |        |                                     |  |        |                       |  |   |                     |   |                     |
|                            | 02                                  | Torque reference (1 V/100% rated torque)   |                |              |                 |                   |              |                |           |                                   |  |    |  |                              |    |  |                                  |    |  |  |    |  |    |  |   |    |   |   |    |                                     |    |   |    |   |    |  |                                    |    |  |  |    |  |    |  |    |                                     |    |                                     |    |                                     |    |                         |          |                                      |        |                                     |  |        |                       |  |   |                     |   |                     |
|                            |                                     | Force reference (1 V/100% rated force)   |                |              |                 |                   |              |                |           |                                   |  |    |  |                              |    |  |                                  |    |  |  |    |  |    |  |   |    |   |   |    |                                     |    |   |    |   |    |  |                                    |    |  |  |    |  |    |  |    |                                     |    |                                     |    |                                     |    |                         |          |                                      |        |                                     |  |        |                       |  |   |                     |   |                     |
|                            | 03                                  | Position deviation (0.05 V/reference unit)   |                |              |                 |                   |              |                |           |                                   |  |    |  |                              |    |  |                                  |    |  |  |    |  |    |  |   |    |   |   |    |                                     |    |   |    |   |    |  |                                    |    |  |  |    |  |    |  |    |                                     |    |                                     |    |                                     |    |                         |          |                                      |        |                                     |  |        |                       |  |   |                     |   |                     |
|                            | 04                                  | Position amplifier deviation (after electronic gear) (0.05 V/encoder pulse unit)   |                |              |                 |                   |              |                |           |                                   |  |    |  |                              |    |  |                                  |    |  |  |    |  |    |  |   |    |   |   |    |                                     |    |   |    |   |    |  |                                    |    |  |  |    |  |    |  |    |                                     |    |                                     |    |                                     |    |                         |          |                                      |        |                                     |  |        |                       |  |   |                     |   |                     |
|                            |                                     | Position amplifier deviation (after electronic gear) (0.05 V/linear encoder pulse unit)  |                |              |                 |                   |              |                |           |                                   |  |    |  |                              |    |  |                                  |    |  |  |    |  |    |  |   |    |   |   |    |                                     |    |   |    |   |    |  |                                    |    |  |  |    |  |    |  |    |                                     |    |                                     |    |                                     |    |                         |          |                                      |        |                                     |  |        |                       |  |   |                     |   |                     |
|                            | 05                                  | Position reference speed (1 V/1,000 min <sup>-1</sup> )  |                |              |                 |                   |              |                |           |                                   |  |    |  |                              |    |  |                                  |    |  |  |    |  |    |  |   |    |   |   |    |                                     |    |   |    |   |    |  |                                    |    |  |  |    |  |    |  |    |                                     |    |                                     |    |                                     |    |                         |          |                                      |        |                                     |  |        |                       |  |   |                     |   |                     |
|                            |                                     | Position reference speed (1 V/1,000 mm/s)  |                |              |                 |                   |              |                |           |                                   |  |    |  |                              |    |  |                                  |    |  |  |    |  |    |  |   |    |   |   |    |                                     |    |   |    |   |    |  |                                    |    |  |  |    |  |    |  |    |                                     |    |                                     |    |                                     |    |                         |          |                                      |        |                                     |  |        |                       |  |   |                     |   |                     |
|                            | 06                                  | Reserved parameter (Do not change.)  |                |              |                 |                   |              |                |           |                                   |  |    |  |                              |    |  |                                  |    |  |  |    |  |    |  |   |    |   |   |    |                                     |    |   |    |   |    |  |                                    |    |  |  |    |  |    |  |    |                                     |    |                                     |    |                                     |    |                         |          |                                      |        |                                     |  |        |                       |  |   |                     |   |                     |
|                            | 07                                  | Load-motor position deviation (0.01 V/reference unit)  |                |              |                 |                   |              |                |           |                                   |  |    |  |                              |    |  |                                  |    |  |  |    |  |    |  |   |    |   |   |    |                                     |    |   |    |   |    |  |                                    |    |  |  |    |  |    |  |    |                                     |    |                                     |    |                                     |    |                         |          |                                      |        |                                     |  |        |                       |  |   |                     |   |                     |
|                            | 08                                  | Positioning completion (positioning completed: 5 V, positioning not completed: 0 V)  |                |              |                 |                   |              |                |           |                                   |  |    |  |                              |    |  |                                  |    |  |  |    |  |    |  |   |    |   |   |    |                                     |    |   |    |   |    |  |                                    |    |  |  |    |  |    |  |    |                                     |    |                                     |    |                                     |    |                         |          |                                      |        |                                     |  |        |                       |  |   |                     |   |                     |
|                            | 09                                  | Speed feedforward (1 V/1,000 min <sup>-1</sup> )   |                |              |                 |                   |              |                |           |                                   |  |    |  |                              |    |  |                                  |    |  |  |    |  |    |  |   |    |   |   |    |                                     |    |   |    |   |    |  |                                    |    |  |  |    |  |    |  |    |                                     |    |                                     |    |                                     |    |                         |          |                                      |        |                                     |  |        |                       |  |   |                     |   |                     |
|                            |                                     | Speed feedforward (1 V/1,000 mm/s)   |                |              |                 |                   |              |                |           |                                   |  |    |  |                              |    |  |                                  |    |  |  |    |  |    |  |   |    |   |   |    |                                     |    |   |    |   |    |  |                                    |    |  |  |    |  |    |  |    |                                     |    |                                     |    |                                     |    |                         |          |                                      |        |                                     |  |        |                       |  |   |                     |   |                     |
|                            | 0A                                  | Torque feedforward (1 V/100% rated torque)   |                |              |                 |                   |              |                |           |                                   |  |    |  |                              |    |  |                                  |    |  |  |    |  |    |  |   |    |   |   |    |                                     |    |   |    |   |    |  |                                    |    |  |  |    |  |    |  |    |                                     |    |                                     |    |                                     |    |                         |          |                                      |        |                                     |  |        |                       |  |   |                     |   |                     |
|                            |                                     | Force feedforward (1 V/100% rated force)   |                |              |                 |                   |              |                |           |                                   |  |    |  |                              |    |  |                                  |    |  |  |    |  |    |  |   |    |   |   |    |                                     |    |   |    |   |    |  |                                    |    |  |  |    |  |    |  |    |                                     |    |                                     |    |                                     |    |                         |          |                                      |        |                                     |  |        |                       |  |   |                     |   |                     |
|                            | 0B                                  | Active gain (1st gain: 1 V, 2nd gain: 2 V)   |                |              |                 |                   |              |                |           |                                   |  |    |  |                              |    |  |                                  |    |  |  |    |  |    |  |   |    |   |   |    |                                     |    |   |    |   |    |  |                                    |    |  |  |    |  |    |  |    |                                     |    |                                     |    |                                     |    |                         |          |                                      |        |                                     |  |        |                       |  |   |                     |   |                     |
|                            | 0C                                  | Completion of position reference distribution (completed: 5 V, not completed: 0 V)   |                |              |                 |                   |              |                |           |                                   |  |    |  |                              |    |  |                                  |    |  |  |    |  |    |  |   |    |   |   |    |                                     |    |   |    |   |    |  |                                    |    |  |  |    |  |    |  |    |                                     |    |                                     |    |                                     |    |                         |          |                                      |        |                                     |  |        |                       |  |   |                     |   |                     |
|                            | 0D                                  | Reserved parameter (Do not change.)  |                |              |                 |                   |              |                |           |                                   |  |    |  |                              |    |  |                                  |    |  |  |    |  |    |  |   |    |   |   |    |                                     |    |   |    |   |    |  |                                    |    |  |  |    |  |    |  |    |                                     |    |                                     |    |                                     |    |                         |          |                                      |        |                                     |  |        |                       |  |   |                     |   |                     |
|                            | 0E                                  | Reserved parameter (Do not change.)  |                |              |                 |                   |              |                |           |                                   |  |    |  |                              |    |  |                                  |    |  |  |    |  |    |  |   |    |   |   |    |                                     |    |   |    |   |    |  |                                    |    |  |  |    |  |    |  |    |                                     |    |                                     |    |                                     |    |                         |          |                                      |        |                                     |  |        |                       |  |   |                     |   |                     |
|                            | 0F                                  | Reserved parameter (Do not change.)  |                |              |                 |                   |              |                |           |                                   |  |    |  |                              |    |  |                                  |    |  |  |    |  |    |  |   |    |   |   |    |                                     |    |   |    |   |    |  |                                    |    |  |  |    |  |    |  |    |                                     |    |                                     |    |                                     |    |                         |          |                                      |        |                                     |  |        |                       |  |   |                     |   |                     |
|                            | 10                                  | Main circuit DC voltage  |                |              |                 |                   |              |                |           |                                   |  |    |  |                              |    |  |                                  |    |  |  |    |  |    |  |   |    |   |   |    |                                     |    |   |    |   |    |  |                                    |    |  |  |    |  |    |  |    |                                     |    |                                     |    |                                     |    |                         |          |                                      |        |                                     |  |        |                       |  |   |                     |   |                     |
|                            | 11 to 5F                            | Reserved parameters (Do not change.)   |                |              |                 |                   |              |                |           |                                   |  |    |  |                              |    |  |                                  |    |  |  |    |  |    |  |   |    |   |   |    |                                     |    |   |    |   |    |  |                                    |    |  |  |    |  |    |  |    |                                     |    |                                     |    |                                     |    |                         |          |                                      |        |                                     |  |        |                       |  |   |                     |   |                     |
| n.□□□□                     | Reserved parameter (Do not change.) |  |                |              |                 |                   |              |                |           |                                   |  |    |  |                              |    |  |                                  |    |  |  |    |  |    |  |   |    |   |   |    |                                     |    |   |    |   |    |  |                                    |    |  |  |    |  |    |  |    |                                     |    |                                     |    |                                     |    |                         |          |                                      |        |                                     |  |        |                       |  |   |                     |   |                     |
| n.X□□□                     | Output Axis Selection               |  |                |              |                 |                   |              |                |           |                                   |  |    |  |                              |    |  |                                  |    |  |  |    |  |    |  |   |    |   |   |    |                                     |    |   |    |   |    |  |                                    |    |  |  |    |  |    |  |    |                                     |    |                                     |    |                                     |    |                         |          |                                      |        |                                     |  |        |                       |  |   |                     |   |                     |
|                            | 0                                   | Output axis A data.  |                |              |                 |                   |              |                |           |                                   |  |    |  |                              |    |  |                                  |    |  |  |    |  |    |  |   |    |   |   |    |                                     |    |   |    |   |    |  |                                    |    |  |  |    |  |    |  |    |                                     |    |                                     |    |                                     |    |                         |          |                                      |        |                                     |  |        |                       |  |   |                     |   |                     |
|                            | 1                                   | Output axis B data.  |                |              |                 |                   |              |                |           |                                   |  |    |  |                              |    |  |                                  |    |  |  |    |  |    |  |   |    |   |   |    |                                     |    |   |    |   |    |  |                                    |    |  |  |    |  |    |  |    |                                     |    |                                     |    |                                     |    |                         |          |                                      |        |                                     |  |        |                       |  |   |                     |   |                     |

Continued on next page.

Continued from previous page.

| Parameter No.              | Size  | Name  | Setting Range  | Setting Unit | Default Setting | Applicable Motors | When Enabled | Classification | Reference |  |        |  |  |  |  |  |  |  |  |  |    |  |  |  |  |  |  |  |  |  |    |  |  |  |  |  |  |  |  |  |    |  |  |  |  |  |  |  |  |  |    |  |  |  |  |  |  |  |  |  |    |   |  |  |  |  |  |  |  |  |    |  |  |  |  |  |  |  |  |  |    |                                     |  |  |  |  |  |  |  |  |    |   |  |  |  |  |  |  |  |  |    |   |  |  |  |  |  |  |  |  |    |  |  |  |  |  |  |  |  |  |    |  |  |  |  |  |  |  |  |  |    |  |  |  |  |  |  |  |  |  |    |  |  |  |  |  |  |  |  |  |    |                                     |  |  |  |  |  |  |  |  |    |                                     |  |  |  |  |  |  |  |  |    |                                     |  |  |  |  |  |  |  |  |    |                         |  |  |  |  |  |  |  |  |          |                                      |  |  |  |  |  |  |  |  |        |  |  |  |  |  |  |  |  |  |        |                              |  |  |  |  |  |  |  |  |   |                     |  |  |  |  |  |  |  |  |   |                     |  |  |  |  |  |  |  |  |
|----------------------------|---|---|----------------|--------------|-----------------|-------------------|--------------|----------------|-----------|--|--------|--|--|--|--|--|--|--|--|--|----|--|--|--|--|--|--|--|--|--|----|--|--|--|--|--|--|--|--|--|----|--|--|--|--|--|--|--|--|--|----|--|--|--|--|--|--|--|--|--|----|---|--|--|--|--|--|--|--|--|----|--|--|--|--|--|--|--|--|--|----|-------------------------------------|--|--|--|--|--|--|--|--|----|---|--|--|--|--|--|--|--|--|----|---|--|--|--|--|--|--|--|--|----|--|--|--|--|--|--|--|--|--|----|--|--|--|--|--|--|--|--|--|----|--|--|--|--|--|--|--|--|--|----|--|--|--|--|--|--|--|--|--|----|-------------------------------------|--|--|--|--|--|--|--|--|----|-------------------------------------|--|--|--|--|--|--|--|--|----|-------------------------------------|--|--|--|--|--|--|--|--|----|-------------------------|--|--|--|--|--|--|--|--|----------|--------------------------------------|--|--|--|--|--|--|--|--|--------|--|--|--|--|--|--|--|--|--|--------|------------------------------|--|--|--|--|--|--|--|--|---|---------------------|--|--|--|--|--|--|--|--|---|---------------------|--|--|--|--|--|--|--|--|
| Pn007<br>(2007h)<br>Common | 2   | Application Function Selections 7   | 0000h to 105Fh | -            | 0000h           | All               | Immediately  | Setup          | page 10-9 |  |        |  |  |  |  |  |  |  |  |  |    |  |  |  |  |  |  |  |  |  |    |  |  |  |  |  |  |  |  |  |    |  |  |  |  |  |  |  |  |  |    |  |  |  |  |  |  |  |  |  |    |   |  |  |  |  |  |  |  |  |    |  |  |  |  |  |  |  |  |  |    |                                     |  |  |  |  |  |  |  |  |    |   |  |  |  |  |  |  |  |  |    |   |  |  |  |  |  |  |  |  |    |  |  |  |  |  |  |  |  |  |    |  |  |  |  |  |  |  |  |  |    |  |  |  |  |  |  |  |  |  |    |  |  |  |  |  |  |  |  |  |    |                                     |  |  |  |  |  |  |  |  |    |                                     |  |  |  |  |  |  |  |  |    |                                     |  |  |  |  |  |  |  |  |    |                         |  |  |  |  |  |  |  |  |          |                                      |  |  |  |  |  |  |  |  |        |  |  |  |  |  |  |  |  |  |        |                              |  |  |  |  |  |  |  |  |   |                     |  |  |  |  |  |  |  |  |   |                     |  |  |  |  |  |  |  |  |
|                            | <table border="1"> <tr> <td>n.□□XX</td> <td colspan="9"><b>Analog Monitor 2 Signal Selection</b></td> </tr> <tr> <td>00</td> <td colspan="9">Motor speed (1 V/1,000 min<sup>-1</sup>)<br/>Motor speed (1 V/1,000 mm/s)</td> </tr> <tr> <td>01</td> <td colspan="9">Speed reference (1 V/1,000 min<sup>-1</sup>)<br/>Speed reference (1 V/1,000 mm/s)</td> </tr> <tr> <td>02</td> <td colspan="9">Torque reference (1 V/100% rated torque)<br/>Force reference (1 V/100% rated force)</td> </tr> <tr> <td>03</td> <td colspan="9">Position deviation (0.05 V/reference unit)</td> </tr> <tr> <td>04</td> <td colspan="9">Position amplifier deviation (after electronic gear) (0.05 V/encoder pulse unit)<br/>Position amplifier deviation (after electronic gear) (0.05 V/linear encoder pulse unit)</td> </tr> <tr> <td>05</td> <td colspan="9">Position reference speed (1 V/1,000 min<sup>-1</sup>)<br/>Position reference speed (1 V/1,000 mm/s)</td> </tr> <tr> <td>06</td> <td colspan="9">Reserved parameter (Do not change.)</td> </tr> <tr> <td>07</td> <td colspan="9">Load-motor position deviation (0.01 V/reference unit)</td> </tr> <tr> <td>08</td> <td colspan="9">Positioning completion (positioning completed: 5 V, positioning not completed: 0 V)</td> </tr> <tr> <td>09</td> <td colspan="9">Speed feedforward (1 V/1,000 min<sup>-1</sup>)<br/>Speed feedforward (1 V/1,000 mm/s)</td> </tr> <tr> <td>0A</td> <td colspan="9">Torque feedforward (1 V/100% rated torque)<br/>Force feedforward (1 V/100% rated force)</td> </tr> <tr> <td>0B</td> <td colspan="9">Active gain (1st gain: 1 V, 2nd gain: 2 V)</td> </tr> <tr> <td>0C</td> <td colspan="9">Completion of position reference distribution (completed: 5 V, not completed: 0 V)</td> </tr> <tr> <td>0D</td> <td colspan="9">Reserved parameter (Do not change.)</td> </tr> <tr> <td>0E</td> <td colspan="9">Reserved parameter (Do not change.)</td> </tr> <tr> <td>0F</td> <td colspan="9">Reserved parameter (Do not change.)</td> </tr> <tr> <td>10</td> <td colspan="9">Main circuit DC voltage</td> </tr> <tr> <td>11 to 5F</td> <td colspan="9">Reserved parameters (Do not change.)</td> </tr> <tr> <td>n.□X□□</td> <td colspan="9"><b>Reserved parameter (Do not change.)</b></td> </tr> <tr> <td>n.X□□□</td> <td colspan="9"><b>Output Axis Selection</b></td> </tr> <tr> <td>0</td> <td colspan="9">Output axis A data.</td> </tr> <tr> <td>1</td> <td colspan="9">Output axis B data.</td> </tr> </table> |   |                |              |                 |                   |              |                |           |  | n.□□XX | <b>Analog Monitor 2 Signal Selection</b> |  |  |  |  |  |  |  |  | 00 | Motor speed (1 V/1,000 min <sup>-1</sup> )<br>Motor speed (1 V/1,000 mm/s) |  |  |  |  |  |  |  |  | 01 | Speed reference (1 V/1,000 min <sup>-1</sup> )<br>Speed reference (1 V/1,000 mm/s) |  |  |  |  |  |  |  |  | 02 | Torque reference (1 V/100% rated torque)<br>Force reference (1 V/100% rated force) |  |  |  |  |  |  |  |  | 03 | Position deviation (0.05 V/reference unit) |  |  |  |  |  |  |  |  | 04 | Position amplifier deviation (after electronic gear) (0.05 V/encoder pulse unit)<br>Position amplifier deviation (after electronic gear) (0.05 V/linear encoder pulse unit) |  |  |  |  |  |  |  |  | 05 | Position reference speed (1 V/1,000 min <sup>-1</sup> )<br>Position reference speed (1 V/1,000 mm/s) |  |  |  |  |  |  |  |  | 06 | Reserved parameter (Do not change.) |  |  |  |  |  |  |  |  | 07 | Load-motor position deviation (0.01 V/reference unit) |  |  |  |  |  |  |  |  | 08 | Positioning completion (positioning completed: 5 V, positioning not completed: 0 V) |  |  |  |  |  |  |  |  | 09 | Speed feedforward (1 V/1,000 min <sup>-1</sup> )<br>Speed feedforward (1 V/1,000 mm/s) |  |  |  |  |  |  |  |  | 0A | Torque feedforward (1 V/100% rated torque)<br>Force feedforward (1 V/100% rated force) |  |  |  |  |  |  |  |  | 0B | Active gain (1st gain: 1 V, 2nd gain: 2 V) |  |  |  |  |  |  |  |  | 0C | Completion of position reference distribution (completed: 5 V, not completed: 0 V) |  |  |  |  |  |  |  |  | 0D | Reserved parameter (Do not change.) |  |  |  |  |  |  |  |  | 0E | Reserved parameter (Do not change.) |  |  |  |  |  |  |  |  | 0F | Reserved parameter (Do not change.) |  |  |  |  |  |  |  |  | 10 | Main circuit DC voltage |  |  |  |  |  |  |  |  | 11 to 5F | Reserved parameters (Do not change.) |  |  |  |  |  |  |  |  | n.□X□□ | <b>Reserved parameter (Do not change.)</b> |  |  |  |  |  |  |  |  | n.X□□□ | <b>Output Axis Selection</b> |  |  |  |  |  |  |  |  | 0 | Output axis A data. |  |  |  |  |  |  |  |  | 1 | Output axis B data. |  |  |  |  |  |  |  |  |
|                            | n.□□XX  | <b>Analog Monitor 2 Signal Selection</b>  |                |              |                 |                   |              |                |           |  |        |  |  |  |  |  |  |  |  |  |    |  |  |  |  |  |  |  |  |  |    |  |  |  |  |  |  |  |  |  |    |  |  |  |  |  |  |  |  |  |    |  |  |  |  |  |  |  |  |  |    |   |  |  |  |  |  |  |  |  |    |  |  |  |  |  |  |  |  |  |    |                                     |  |  |  |  |  |  |  |  |    |   |  |  |  |  |  |  |  |  |    |   |  |  |  |  |  |  |  |  |    |  |  |  |  |  |  |  |  |  |    |  |  |  |  |  |  |  |  |  |    |  |  |  |  |  |  |  |  |  |    |  |  |  |  |  |  |  |  |  |    |                                     |  |  |  |  |  |  |  |  |    |                                     |  |  |  |  |  |  |  |  |    |                                     |  |  |  |  |  |  |  |  |    |                         |  |  |  |  |  |  |  |  |          |                                      |  |  |  |  |  |  |  |  |        |  |  |  |  |  |  |  |  |  |        |                              |  |  |  |  |  |  |  |  |   |                     |  |  |  |  |  |  |  |  |   |                     |  |  |  |  |  |  |  |  |
|                            | 00  | Motor speed (1 V/1,000 min <sup>-1</sup> )<br>Motor speed (1 V/1,000 mm/s)  |                |              |                 |                   |              |                |           |  |        |  |  |  |  |  |  |  |  |  |    |  |  |  |  |  |  |  |  |  |    |  |  |  |  |  |  |  |  |  |    |  |  |  |  |  |  |  |  |  |    |  |  |  |  |  |  |  |  |  |    |   |  |  |  |  |  |  |  |  |    |  |  |  |  |  |  |  |  |  |    |                                     |  |  |  |  |  |  |  |  |    |   |  |  |  |  |  |  |  |  |    |   |  |  |  |  |  |  |  |  |    |  |  |  |  |  |  |  |  |  |    |  |  |  |  |  |  |  |  |  |    |  |  |  |  |  |  |  |  |  |    |  |  |  |  |  |  |  |  |  |    |                                     |  |  |  |  |  |  |  |  |    |                                     |  |  |  |  |  |  |  |  |    |                                     |  |  |  |  |  |  |  |  |    |                         |  |  |  |  |  |  |  |  |          |                                      |  |  |  |  |  |  |  |  |        |  |  |  |  |  |  |  |  |  |        |                              |  |  |  |  |  |  |  |  |   |                     |  |  |  |  |  |  |  |  |   |                     |  |  |  |  |  |  |  |  |
|                            | 01  | Speed reference (1 V/1,000 min <sup>-1</sup> )<br>Speed reference (1 V/1,000 mm/s)  |                |              |                 |                   |              |                |           |  |        |  |  |  |  |  |  |  |  |  |    |  |  |  |  |  |  |  |  |  |    |  |  |  |  |  |  |  |  |  |    |  |  |  |  |  |  |  |  |  |    |  |  |  |  |  |  |  |  |  |    |   |  |  |  |  |  |  |  |  |    |  |  |  |  |  |  |  |  |  |    |                                     |  |  |  |  |  |  |  |  |    |   |  |  |  |  |  |  |  |  |    |   |  |  |  |  |  |  |  |  |    |  |  |  |  |  |  |  |  |  |    |  |  |  |  |  |  |  |  |  |    |  |  |  |  |  |  |  |  |  |    |  |  |  |  |  |  |  |  |  |    |                                     |  |  |  |  |  |  |  |  |    |                                     |  |  |  |  |  |  |  |  |    |                                     |  |  |  |  |  |  |  |  |    |                         |  |  |  |  |  |  |  |  |          |                                      |  |  |  |  |  |  |  |  |        |  |  |  |  |  |  |  |  |  |        |                              |  |  |  |  |  |  |  |  |   |                     |  |  |  |  |  |  |  |  |   |                     |  |  |  |  |  |  |  |  |
|                            | 02  | Torque reference (1 V/100% rated torque)<br>Force reference (1 V/100% rated force)  |                |              |                 |                   |              |                |           |  |        |  |  |  |  |  |  |  |  |  |    |  |  |  |  |  |  |  |  |  |    |  |  |  |  |  |  |  |  |  |    |  |  |  |  |  |  |  |  |  |    |  |  |  |  |  |  |  |  |  |    |   |  |  |  |  |  |  |  |  |    |  |  |  |  |  |  |  |  |  |    |                                     |  |  |  |  |  |  |  |  |    |   |  |  |  |  |  |  |  |  |    |   |  |  |  |  |  |  |  |  |    |  |  |  |  |  |  |  |  |  |    |  |  |  |  |  |  |  |  |  |    |  |  |  |  |  |  |  |  |  |    |  |  |  |  |  |  |  |  |  |    |                                     |  |  |  |  |  |  |  |  |    |                                     |  |  |  |  |  |  |  |  |    |                                     |  |  |  |  |  |  |  |  |    |                         |  |  |  |  |  |  |  |  |          |                                      |  |  |  |  |  |  |  |  |        |  |  |  |  |  |  |  |  |  |        |                              |  |  |  |  |  |  |  |  |   |                     |  |  |  |  |  |  |  |  |   |                     |  |  |  |  |  |  |  |  |
|                            | 03  | Position deviation (0.05 V/reference unit)  |                |              |                 |                   |              |                |           |  |        |  |  |  |  |  |  |  |  |  |    |  |  |  |  |  |  |  |  |  |    |  |  |  |  |  |  |  |  |  |    |  |  |  |  |  |  |  |  |  |    |  |  |  |  |  |  |  |  |  |    |   |  |  |  |  |  |  |  |  |    |  |  |  |  |  |  |  |  |  |    |                                     |  |  |  |  |  |  |  |  |    |   |  |  |  |  |  |  |  |  |    |   |  |  |  |  |  |  |  |  |    |  |  |  |  |  |  |  |  |  |    |  |  |  |  |  |  |  |  |  |    |  |  |  |  |  |  |  |  |  |    |  |  |  |  |  |  |  |  |  |    |                                     |  |  |  |  |  |  |  |  |    |                                     |  |  |  |  |  |  |  |  |    |                                     |  |  |  |  |  |  |  |  |    |                         |  |  |  |  |  |  |  |  |          |                                      |  |  |  |  |  |  |  |  |        |  |  |  |  |  |  |  |  |  |        |                              |  |  |  |  |  |  |  |  |   |                     |  |  |  |  |  |  |  |  |   |                     |  |  |  |  |  |  |  |  |
|                            | 04  | Position amplifier deviation (after electronic gear) (0.05 V/encoder pulse unit)<br>Position amplifier deviation (after electronic gear) (0.05 V/linear encoder pulse unit) |                |              |                 |                   |              |                |           |  |        |  |  |  |  |  |  |  |  |  |    |  |  |  |  |  |  |  |  |  |    |  |  |  |  |  |  |  |  |  |    |  |  |  |  |  |  |  |  |  |    |  |  |  |  |  |  |  |  |  |    |   |  |  |  |  |  |  |  |  |    |  |  |  |  |  |  |  |  |  |    |                                     |  |  |  |  |  |  |  |  |    |   |  |  |  |  |  |  |  |  |    |   |  |  |  |  |  |  |  |  |    |  |  |  |  |  |  |  |  |  |    |  |  |  |  |  |  |  |  |  |    |  |  |  |  |  |  |  |  |  |    |  |  |  |  |  |  |  |  |  |    |                                     |  |  |  |  |  |  |  |  |    |                                     |  |  |  |  |  |  |  |  |    |                                     |  |  |  |  |  |  |  |  |    |                         |  |  |  |  |  |  |  |  |          |                                      |  |  |  |  |  |  |  |  |        |  |  |  |  |  |  |  |  |  |        |                              |  |  |  |  |  |  |  |  |   |                     |  |  |  |  |  |  |  |  |   |                     |  |  |  |  |  |  |  |  |
|                            | 05  | Position reference speed (1 V/1,000 min <sup>-1</sup> )<br>Position reference speed (1 V/1,000 mm/s)  |                |              |                 |                   |              |                |           |  |        |  |  |  |  |  |  |  |  |  |    |  |  |  |  |  |  |  |  |  |    |  |  |  |  |  |  |  |  |  |    |  |  |  |  |  |  |  |  |  |    |  |  |  |  |  |  |  |  |  |    |   |  |  |  |  |  |  |  |  |    |  |  |  |  |  |  |  |  |  |    |                                     |  |  |  |  |  |  |  |  |    |   |  |  |  |  |  |  |  |  |    |   |  |  |  |  |  |  |  |  |    |  |  |  |  |  |  |  |  |  |    |  |  |  |  |  |  |  |  |  |    |  |  |  |  |  |  |  |  |  |    |  |  |  |  |  |  |  |  |  |    |                                     |  |  |  |  |  |  |  |  |    |                                     |  |  |  |  |  |  |  |  |    |                                     |  |  |  |  |  |  |  |  |    |                         |  |  |  |  |  |  |  |  |          |                                      |  |  |  |  |  |  |  |  |        |  |  |  |  |  |  |  |  |  |        |                              |  |  |  |  |  |  |  |  |   |                     |  |  |  |  |  |  |  |  |   |                     |  |  |  |  |  |  |  |  |
|                            | 06  | Reserved parameter (Do not change.)   |                |              |                 |                   |              |                |           |  |        |  |  |  |  |  |  |  |  |  |    |  |  |  |  |  |  |  |  |  |    |  |  |  |  |  |  |  |  |  |    |  |  |  |  |  |  |  |  |  |    |  |  |  |  |  |  |  |  |  |    |   |  |  |  |  |  |  |  |  |    |  |  |  |  |  |  |  |  |  |    |                                     |  |  |  |  |  |  |  |  |    |   |  |  |  |  |  |  |  |  |    |   |  |  |  |  |  |  |  |  |    |  |  |  |  |  |  |  |  |  |    |  |  |  |  |  |  |  |  |  |    |  |  |  |  |  |  |  |  |  |    |  |  |  |  |  |  |  |  |  |    |                                     |  |  |  |  |  |  |  |  |    |                                     |  |  |  |  |  |  |  |  |    |                                     |  |  |  |  |  |  |  |  |    |                         |  |  |  |  |  |  |  |  |          |                                      |  |  |  |  |  |  |  |  |        |  |  |  |  |  |  |  |  |  |        |                              |  |  |  |  |  |  |  |  |   |                     |  |  |  |  |  |  |  |  |   |                     |  |  |  |  |  |  |  |  |
|                            | 07  | Load-motor position deviation (0.01 V/reference unit)   |                |              |                 |                   |              |                |           |  |        |  |  |  |  |  |  |  |  |  |    |  |  |  |  |  |  |  |  |  |    |  |  |  |  |  |  |  |  |  |    |  |  |  |  |  |  |  |  |  |    |  |  |  |  |  |  |  |  |  |    |   |  |  |  |  |  |  |  |  |    |  |  |  |  |  |  |  |  |  |    |                                     |  |  |  |  |  |  |  |  |    |   |  |  |  |  |  |  |  |  |    |   |  |  |  |  |  |  |  |  |    |  |  |  |  |  |  |  |  |  |    |  |  |  |  |  |  |  |  |  |    |  |  |  |  |  |  |  |  |  |    |  |  |  |  |  |  |  |  |  |    |                                     |  |  |  |  |  |  |  |  |    |                                     |  |  |  |  |  |  |  |  |    |                                     |  |  |  |  |  |  |  |  |    |                         |  |  |  |  |  |  |  |  |          |                                      |  |  |  |  |  |  |  |  |        |  |  |  |  |  |  |  |  |  |        |                              |  |  |  |  |  |  |  |  |   |                     |  |  |  |  |  |  |  |  |   |                     |  |  |  |  |  |  |  |  |
|                            | 08  | Positioning completion (positioning completed: 5 V, positioning not completed: 0 V)   |                |              |                 |                   |              |                |           |  |        |  |  |  |  |  |  |  |  |  |    |  |  |  |  |  |  |  |  |  |    |  |  |  |  |  |  |  |  |  |    |  |  |  |  |  |  |  |  |  |    |  |  |  |  |  |  |  |  |  |    |   |  |  |  |  |  |  |  |  |    |  |  |  |  |  |  |  |  |  |    |                                     |  |  |  |  |  |  |  |  |    |   |  |  |  |  |  |  |  |  |    |   |  |  |  |  |  |  |  |  |    |  |  |  |  |  |  |  |  |  |    |  |  |  |  |  |  |  |  |  |    |  |  |  |  |  |  |  |  |  |    |  |  |  |  |  |  |  |  |  |    |                                     |  |  |  |  |  |  |  |  |    |                                     |  |  |  |  |  |  |  |  |    |                                     |  |  |  |  |  |  |  |  |    |                         |  |  |  |  |  |  |  |  |          |                                      |  |  |  |  |  |  |  |  |        |  |  |  |  |  |  |  |  |  |        |                              |  |  |  |  |  |  |  |  |   |                     |  |  |  |  |  |  |  |  |   |                     |  |  |  |  |  |  |  |  |
|                            | 09  | Speed feedforward (1 V/1,000 min <sup>-1</sup> )<br>Speed feedforward (1 V/1,000 mm/s)  |                |              |                 |                   |              |                |           |  |        |  |  |  |  |  |  |  |  |  |    |  |  |  |  |  |  |  |  |  |    |  |  |  |  |  |  |  |  |  |    |  |  |  |  |  |  |  |  |  |    |  |  |  |  |  |  |  |  |  |    |   |  |  |  |  |  |  |  |  |    |  |  |  |  |  |  |  |  |  |    |                                     |  |  |  |  |  |  |  |  |    |   |  |  |  |  |  |  |  |  |    |   |  |  |  |  |  |  |  |  |    |  |  |  |  |  |  |  |  |  |    |  |  |  |  |  |  |  |  |  |    |  |  |  |  |  |  |  |  |  |    |  |  |  |  |  |  |  |  |  |    |                                     |  |  |  |  |  |  |  |  |    |                                     |  |  |  |  |  |  |  |  |    |                                     |  |  |  |  |  |  |  |  |    |                         |  |  |  |  |  |  |  |  |          |                                      |  |  |  |  |  |  |  |  |        |  |  |  |  |  |  |  |  |  |        |                              |  |  |  |  |  |  |  |  |   |                     |  |  |  |  |  |  |  |  |   |                     |  |  |  |  |  |  |  |  |
|                            | 0A  | Torque feedforward (1 V/100% rated torque)<br>Force feedforward (1 V/100% rated force)  |                |              |                 |                   |              |                |           |  |        |  |  |  |  |  |  |  |  |  |    |  |  |  |  |  |  |  |  |  |    |  |  |  |  |  |  |  |  |  |    |  |  |  |  |  |  |  |  |  |    |  |  |  |  |  |  |  |  |  |    |   |  |  |  |  |  |  |  |  |    |  |  |  |  |  |  |  |  |  |    |                                     |  |  |  |  |  |  |  |  |    |   |  |  |  |  |  |  |  |  |    |   |  |  |  |  |  |  |  |  |    |  |  |  |  |  |  |  |  |  |    |  |  |  |  |  |  |  |  |  |    |  |  |  |  |  |  |  |  |  |    |  |  |  |  |  |  |  |  |  |    |                                     |  |  |  |  |  |  |  |  |    |                                     |  |  |  |  |  |  |  |  |    |                                     |  |  |  |  |  |  |  |  |    |                         |  |  |  |  |  |  |  |  |          |                                      |  |  |  |  |  |  |  |  |        |  |  |  |  |  |  |  |  |  |        |                              |  |  |  |  |  |  |  |  |   |                     |  |  |  |  |  |  |  |  |   |                     |  |  |  |  |  |  |  |  |
|                            | 0B  | Active gain (1st gain: 1 V, 2nd gain: 2 V)  |                |              |                 |                   |              |                |           |  |        |  |  |  |  |  |  |  |  |  |    |  |  |  |  |  |  |  |  |  |    |  |  |  |  |  |  |  |  |  |    |  |  |  |  |  |  |  |  |  |    |  |  |  |  |  |  |  |  |  |    |   |  |  |  |  |  |  |  |  |    |  |  |  |  |  |  |  |  |  |    |                                     |  |  |  |  |  |  |  |  |    |   |  |  |  |  |  |  |  |  |    |   |  |  |  |  |  |  |  |  |    |  |  |  |  |  |  |  |  |  |    |  |  |  |  |  |  |  |  |  |    |  |  |  |  |  |  |  |  |  |    |  |  |  |  |  |  |  |  |  |    |                                     |  |  |  |  |  |  |  |  |    |                                     |  |  |  |  |  |  |  |  |    |                                     |  |  |  |  |  |  |  |  |    |                         |  |  |  |  |  |  |  |  |          |                                      |  |  |  |  |  |  |  |  |        |  |  |  |  |  |  |  |  |  |        |                              |  |  |  |  |  |  |  |  |   |                     |  |  |  |  |  |  |  |  |   |                     |  |  |  |  |  |  |  |  |
|                            | 0C  | Completion of position reference distribution (completed: 5 V, not completed: 0 V)  |                |              |                 |                   |              |                |           |  |        |  |  |  |  |  |  |  |  |  |    |  |  |  |  |  |  |  |  |  |    |  |  |  |  |  |  |  |  |  |    |  |  |  |  |  |  |  |  |  |    |  |  |  |  |  |  |  |  |  |    |   |  |  |  |  |  |  |  |  |    |  |  |  |  |  |  |  |  |  |    |                                     |  |  |  |  |  |  |  |  |    |   |  |  |  |  |  |  |  |  |    |   |  |  |  |  |  |  |  |  |    |  |  |  |  |  |  |  |  |  |    |  |  |  |  |  |  |  |  |  |    |  |  |  |  |  |  |  |  |  |    |  |  |  |  |  |  |  |  |  |    |                                     |  |  |  |  |  |  |  |  |    |                                     |  |  |  |  |  |  |  |  |    |                                     |  |  |  |  |  |  |  |  |    |                         |  |  |  |  |  |  |  |  |          |                                      |  |  |  |  |  |  |  |  |        |  |  |  |  |  |  |  |  |  |        |                              |  |  |  |  |  |  |  |  |   |                     |  |  |  |  |  |  |  |  |   |                     |  |  |  |  |  |  |  |  |
|                            | 0D  | Reserved parameter (Do not change.)   |                |              |                 |                   |              |                |           |  |        |  |  |  |  |  |  |  |  |  |    |  |  |  |  |  |  |  |  |  |    |  |  |  |  |  |  |  |  |  |    |  |  |  |  |  |  |  |  |  |    |  |  |  |  |  |  |  |  |  |    |   |  |  |  |  |  |  |  |  |    |  |  |  |  |  |  |  |  |  |    |                                     |  |  |  |  |  |  |  |  |    |   |  |  |  |  |  |  |  |  |    |   |  |  |  |  |  |  |  |  |    |  |  |  |  |  |  |  |  |  |    |  |  |  |  |  |  |  |  |  |    |  |  |  |  |  |  |  |  |  |    |  |  |  |  |  |  |  |  |  |    |                                     |  |  |  |  |  |  |  |  |    |                                     |  |  |  |  |  |  |  |  |    |                                     |  |  |  |  |  |  |  |  |    |                         |  |  |  |  |  |  |  |  |          |                                      |  |  |  |  |  |  |  |  |        |  |  |  |  |  |  |  |  |  |        |                              |  |  |  |  |  |  |  |  |   |                     |  |  |  |  |  |  |  |  |   |                     |  |  |  |  |  |  |  |  |
|                            | 0E  | Reserved parameter (Do not change.)   |                |              |                 |                   |              |                |           |  |        |  |  |  |  |  |  |  |  |  |    |  |  |  |  |  |  |  |  |  |    |  |  |  |  |  |  |  |  |  |    |  |  |  |  |  |  |  |  |  |    |  |  |  |  |  |  |  |  |  |    |   |  |  |  |  |  |  |  |  |    |  |  |  |  |  |  |  |  |  |    |                                     |  |  |  |  |  |  |  |  |    |   |  |  |  |  |  |  |  |  |    |   |  |  |  |  |  |  |  |  |    |  |  |  |  |  |  |  |  |  |    |  |  |  |  |  |  |  |  |  |    |  |  |  |  |  |  |  |  |  |    |  |  |  |  |  |  |  |  |  |    |                                     |  |  |  |  |  |  |  |  |    |                                     |  |  |  |  |  |  |  |  |    |                                     |  |  |  |  |  |  |  |  |    |                         |  |  |  |  |  |  |  |  |          |                                      |  |  |  |  |  |  |  |  |        |  |  |  |  |  |  |  |  |  |        |                              |  |  |  |  |  |  |  |  |   |                     |  |  |  |  |  |  |  |  |   |                     |  |  |  |  |  |  |  |  |
|                            | 0F  | Reserved parameter (Do not change.)   |                |              |                 |                   |              |                |           |  |        |  |  |  |  |  |  |  |  |  |    |  |  |  |  |  |  |  |  |  |    |  |  |  |  |  |  |  |  |  |    |  |  |  |  |  |  |  |  |  |    |  |  |  |  |  |  |  |  |  |    |   |  |  |  |  |  |  |  |  |    |  |  |  |  |  |  |  |  |  |    |                                     |  |  |  |  |  |  |  |  |    |   |  |  |  |  |  |  |  |  |    |   |  |  |  |  |  |  |  |  |    |  |  |  |  |  |  |  |  |  |    |  |  |  |  |  |  |  |  |  |    |  |  |  |  |  |  |  |  |  |    |  |  |  |  |  |  |  |  |  |    |                                     |  |  |  |  |  |  |  |  |    |                                     |  |  |  |  |  |  |  |  |    |                                     |  |  |  |  |  |  |  |  |    |                         |  |  |  |  |  |  |  |  |          |                                      |  |  |  |  |  |  |  |  |        |  |  |  |  |  |  |  |  |  |        |                              |  |  |  |  |  |  |  |  |   |                     |  |  |  |  |  |  |  |  |   |                     |  |  |  |  |  |  |  |  |
|                            | 10  | Main circuit DC voltage   |                |              |                 |                   |              |                |           |  |        |  |  |  |  |  |  |  |  |  |    |  |  |  |  |  |  |  |  |  |    |  |  |  |  |  |  |  |  |  |    |  |  |  |  |  |  |  |  |  |    |  |  |  |  |  |  |  |  |  |    |   |  |  |  |  |  |  |  |  |    |  |  |  |  |  |  |  |  |  |    |                                     |  |  |  |  |  |  |  |  |    |   |  |  |  |  |  |  |  |  |    |   |  |  |  |  |  |  |  |  |    |  |  |  |  |  |  |  |  |  |    |  |  |  |  |  |  |  |  |  |    |  |  |  |  |  |  |  |  |  |    |  |  |  |  |  |  |  |  |  |    |                                     |  |  |  |  |  |  |  |  |    |                                     |  |  |  |  |  |  |  |  |    |                                     |  |  |  |  |  |  |  |  |    |                         |  |  |  |  |  |  |  |  |          |                                      |  |  |  |  |  |  |  |  |        |  |  |  |  |  |  |  |  |  |        |                              |  |  |  |  |  |  |  |  |   |                     |  |  |  |  |  |  |  |  |   |                     |  |  |  |  |  |  |  |  |
|                            | 11 to 5F  | Reserved parameters (Do not change.)  |                |              |                 |                   |              |                |           |  |        |  |  |  |  |  |  |  |  |  |    |  |  |  |  |  |  |  |  |  |    |  |  |  |  |  |  |  |  |  |    |  |  |  |  |  |  |  |  |  |    |  |  |  |  |  |  |  |  |  |    |   |  |  |  |  |  |  |  |  |    |  |  |  |  |  |  |  |  |  |    |                                     |  |  |  |  |  |  |  |  |    |   |  |  |  |  |  |  |  |  |    |   |  |  |  |  |  |  |  |  |    |  |  |  |  |  |  |  |  |  |    |  |  |  |  |  |  |  |  |  |    |  |  |  |  |  |  |  |  |  |    |  |  |  |  |  |  |  |  |  |    |                                     |  |  |  |  |  |  |  |  |    |                                     |  |  |  |  |  |  |  |  |    |                                     |  |  |  |  |  |  |  |  |    |                         |  |  |  |  |  |  |  |  |          |                                      |  |  |  |  |  |  |  |  |        |  |  |  |  |  |  |  |  |  |        |                              |  |  |  |  |  |  |  |  |   |                     |  |  |  |  |  |  |  |  |   |                     |  |  |  |  |  |  |  |  |
|                            | n.□X□□  | <b>Reserved parameter (Do not change.)</b>  |                |              |                 |                   |              |                |           |  |        |  |  |  |  |  |  |  |  |  |    |  |  |  |  |  |  |  |  |  |    |  |  |  |  |  |  |  |  |  |    |  |  |  |  |  |  |  |  |  |    |  |  |  |  |  |  |  |  |  |    |   |  |  |  |  |  |  |  |  |    |  |  |  |  |  |  |  |  |  |    |                                     |  |  |  |  |  |  |  |  |    |   |  |  |  |  |  |  |  |  |    |   |  |  |  |  |  |  |  |  |    |  |  |  |  |  |  |  |  |  |    |  |  |  |  |  |  |  |  |  |    |  |  |  |  |  |  |  |  |  |    |  |  |  |  |  |  |  |  |  |    |                                     |  |  |  |  |  |  |  |  |    |                                     |  |  |  |  |  |  |  |  |    |                                     |  |  |  |  |  |  |  |  |    |                         |  |  |  |  |  |  |  |  |          |                                      |  |  |  |  |  |  |  |  |        |  |  |  |  |  |  |  |  |  |        |                              |  |  |  |  |  |  |  |  |   |                     |  |  |  |  |  |  |  |  |   |                     |  |  |  |  |  |  |  |  |
|                            | n.X□□□  | <b>Output Axis Selection</b>  |                |              |                 |                   |              |                |           |  |        |  |  |  |  |  |  |  |  |  |    |  |  |  |  |  |  |  |  |  |    |  |  |  |  |  |  |  |  |  |    |  |  |  |  |  |  |  |  |  |    |  |  |  |  |  |  |  |  |  |    |   |  |  |  |  |  |  |  |  |    |  |  |  |  |  |  |  |  |  |    |                                     |  |  |  |  |  |  |  |  |    |   |  |  |  |  |  |  |  |  |    |   |  |  |  |  |  |  |  |  |    |  |  |  |  |  |  |  |  |  |    |  |  |  |  |  |  |  |  |  |    |  |  |  |  |  |  |  |  |  |    |  |  |  |  |  |  |  |  |  |    |                                     |  |  |  |  |  |  |  |  |    |                                     |  |  |  |  |  |  |  |  |    |                                     |  |  |  |  |  |  |  |  |    |                         |  |  |  |  |  |  |  |  |          |                                      |  |  |  |  |  |  |  |  |        |  |  |  |  |  |  |  |  |  |        |                              |  |  |  |  |  |  |  |  |   |                     |  |  |  |  |  |  |  |  |   |                     |  |  |  |  |  |  |  |  |
|                            | 0   | Output axis A data.   |                |              |                 |                   |              |                |           |  |        |  |  |  |  |  |  |  |  |  |    |  |  |  |  |  |  |  |  |  |    |  |  |  |  |  |  |  |  |  |    |  |  |  |  |  |  |  |  |  |    |  |  |  |  |  |  |  |  |  |    |   |  |  |  |  |  |  |  |  |    |  |  |  |  |  |  |  |  |  |    |                                     |  |  |  |  |  |  |  |  |    |   |  |  |  |  |  |  |  |  |    |   |  |  |  |  |  |  |  |  |    |  |  |  |  |  |  |  |  |  |    |  |  |  |  |  |  |  |  |  |    |  |  |  |  |  |  |  |  |  |    |  |  |  |  |  |  |  |  |  |    |                                     |  |  |  |  |  |  |  |  |    |                                     |  |  |  |  |  |  |  |  |    |                                     |  |  |  |  |  |  |  |  |    |                         |  |  |  |  |  |  |  |  |          |                                      |  |  |  |  |  |  |  |  |        |  |  |  |  |  |  |  |  |  |        |                              |  |  |  |  |  |  |  |  |   |                     |  |  |  |  |  |  |  |  |   |                     |  |  |  |  |  |  |  |  |
|                            | 1   | Output axis B data.   |                |              |                 |                   |              |                |           |  |        |  |  |  |  |  |  |  |  |  |    |  |  |  |  |  |  |  |  |  |    |  |  |  |  |  |  |  |  |  |    |  |  |  |  |  |  |  |  |  |    |  |  |  |  |  |  |  |  |  |    |   |  |  |  |  |  |  |  |  |    |  |  |  |  |  |  |  |  |  |    |                                     |  |  |  |  |  |  |  |  |    |   |  |  |  |  |  |  |  |  |    |   |  |  |  |  |  |  |  |  |    |  |  |  |  |  |  |  |  |  |    |  |  |  |  |  |  |  |  |  |    |  |  |  |  |  |  |  |  |  |    |  |  |  |  |  |  |  |  |  |    |                                     |  |  |  |  |  |  |  |  |    |                                     |  |  |  |  |  |  |  |  |    |                                     |  |  |  |  |  |  |  |  |    |                         |  |  |  |  |  |  |  |  |          |                                      |  |  |  |  |  |  |  |  |        |  |  |  |  |  |  |  |  |  |        |                              |  |  |  |  |  |  |  |  |   |                     |  |  |  |  |  |  |  |  |   |                     |  |  |  |  |  |  |  |  |

Continued on next page.

Continued from previous page.

| Parameter No.                    | Size                                | Name  | Setting Range  | Setting Unit | Default Setting | Applicable Motors | When Enabled  | Classification | Reference |            |
|----------------------------------|-------------------------------------|---|--|--------------|-----------------|-------------------|---------------|----------------|-----------|------------|
| Pn008<br>(A: 2008h,<br>B: 2808h) | 2                                   | Application Function Selections 8           | 0000h to 7121h   | –            | 4000h           | Rotary            | After restart | Setup          | –         |            |
|                                  | n.□□□X                              | Low Battery Voltage Alarm/Warning Selection |  |              |                 |                   |               |                | Reference |            |
|                                  |                                     | 0   | Output alarm (A.830) for low battery voltage.  |              |                 |                   |               |                |           | page 15-3  |
|                                  |                                     | 1   | Output warning (A.930) for low battery voltage.  |              |                 |                   |               |                |           |            |
|                                  | n.□□X□                              | Function Selection for Undervoltage         |  |              |                 |                   |               |                | Reference |            |
|                                  |                                     | 0   | Do not detect undervoltage.  |              |                 |                   |               |                |           | page 7-19  |
|                                  |                                     | 1   | Detect undervoltage warning and limit torque at host controller.   |              |                 |                   |               |                |           |            |
|                                  |                                     | 2   | Detect undervoltage warning and limit torque with Pn424 (2424h) and Pn425 (2425h) (i.e., only in the SERVOPACK). |              |                 |                   |               |                |           |            |
|                                  | n.□X□□                              | Warning Detection Selection                 |  |              |                 |                   |               |                | Reference |            |
|                                  |                                     | 0   | Detect warnings.   |              |                 |                   |               |                |           | page 15-46 |
|                                  | 1                                   | Do not detect warnings except for A.971.    |  |              |                 |                   |               |                |           |            |
| n.X□□□                           | Reserved parameter (Do not change.) |   |  |              |                 |                   |               |                |           |            |
| Pn009<br>(A: 2009h,<br>B: 2809h) | 2                                   | Application Function Selections 9           | 0000h to 0121h   | –            | 0010h           | All               | After restart | Tuning         | –         |            |
|                                  | n.□□□X                              | Reserved parameter (Do not change.)         |  |              |                 |                   |               |                |           |            |
|                                  | n.□□X□                              | Current Control Mode Selection              |  |              |                 |                   |               |                | Reference |            |
|                                  |                                     | 0   | Use current control mode 1.  |              |                 |                   |               |                |           | page 9-70  |
|                                  |                                     | 1   | Use current control mode 2.  |              |                 |                   |               |                |           |            |
|                                  |                                     | 2   | Reserved parameter (Do not change.)  |              |                 |                   |               |                |           |            |
|                                  | n.□X□□                              | Speed Detection Method Selection            |  |              |                 |                   |               |                | Reference |            |
|                                  |                                     | 0   | Use speed detection 1.   |              |                 |                   |               |                |           | page 9-71  |
|                                  |                                     | 1   | Use speed detection 2.   |              |                 |                   |               |                |           |            |
|                                  | n.X□□□                              | Reserved parameter (Do not change.)         |  |              |                 |                   |               |                |           |            |

Continued on next page.

16.1 List of Servo Parameters

16.1.2 List of Parameters

Continued from previous page.

| Parameter No.                    | Size   | Name  | Setting Range  | Setting Unit | Default Setting | Applicable Motors | When Enabled  | Classification | Reference |           |
|----------------------------------|--------|---|--|--------------|-----------------|-------------------|---------------|----------------|-----------|-----------|
| Pn00A<br>(A: 200Ah,<br>B: 280Ah) | 2      | Application Function Selections A   | 0000h to 1244h   | -            | 0001h           | All               | After restart | Setup          | -         |           |
|                                  | n.□□□X |   | <b>Motor Stopping Method for Group 2 Alarms</b>  |              |                 |                   |               |                |           | Reference |
|                                  | 0      |   | Apply the dynamic brake or coast the motor to a stop (use the stopping method set in Pn001 (2001h) = n.□□□X).  |              |                 |                   |               |                |           | page 6-36 |
|                                  | 1      |   | Decelerate the motor to a stop using the torque set in Pn406 (2406h) as the maximum torque. Use the setting of Pn001 (2001h) = n.□□□X for the status after stopping. |              |                 |                   |               |                |           |           |
|                                  | 2      |   | Decelerate the motor to a stop using the torque set in Pn406 (2406h) as the maximum torque and then let the motor coast.   |              |                 |                   |               |                |           |           |
|                                  | 3      |   | Decelerate the motor to a stop using the deceleration time set in Pn30A (230Ah). Use the setting of Pn001 (2001h) = n.□□□X for the status after stopping.            |              |                 |                   |               |                |           |           |
|                                  | 4      |   | Decelerate the motor to a stop using the deceleration time set in Pn30A (230Ah) and then let the motor coast.  |              |                 |                   |               |                |           |           |
|                                  | n.□□X□ |   | <b>Stopping Method for Forced Stops</b>  |              |                 |                   |               |                |           | Reference |
|                                  | 0      |   | Apply the dynamic brake or coast the motor to a stop (use the stopping method set in Pn001 (2001h) = n.□□□X).  |              |                 |                   |               |                |           | page 7-45 |
|                                  | 1      |   | Decelerate the motor to a stop using the torque set in Pn406 (2406h) as the maximum torque. Use the setting of Pn001 (2001h) = n.□□□X for the status after stopping. |              |                 |                   |               |                |           |           |
|                                  | 2      |   | Decelerate the motor to a stop using the torque set in Pn406 (2406h) as the maximum torque and then let the motor coast.   |              |                 |                   |               |                |           |           |
|                                  | 3      |   | Decelerate the motor to a stop using the deceleration time set in Pn30A (230Ah). Use the setting of Pn001 (2001h) = n.□□□X for the status after stopping.            |              |                 |                   |               |                |           |           |
| 4                                |        | Decelerate the motor to a stop using the deceleration time set in Pn30A (230Ah) and then let the motor coast. |  |              |                 |                   |               |                |           |           |
| n.□X□□                           |        | Reserved parameter (Do not change.)   |  |              |                 |                   |               |                |           |           |
| n.X□□□                           |        | Reserved parameter (Do not change.)   |  |              |                 |                   |               |                |           |           |
| Pn00B<br>(A: 200Bh,<br>B: 280Bh) | 2      | Application Function Selections B   | 0000h to 1121h   | -            | 0000h           | All               | After restart | Setup          | -         |           |
|                                  | n.□□□X |   | <b>Operator Parameter Display Selection</b>  |              |                 |                   |               |                |           | Reference |
|                                  | 0      |   | Display only setup parameters.   |              |                 |                   |               |                |           | page 6-3  |
|                                  | 1      |   | Display all parameters.  |              |                 |                   |               |                |           |           |
|                                  | n.□□X□ |   | <b>Motor Stopping Method for Group 2 Alarms</b>  |              |                 |                   |               |                |           | Reference |
|                                  | 0      |   | Stop the motor by setting the speed reference to 0.  |              |                 |                   |               |                |           | page 6-36 |
|                                  | 1      |   | Apply the dynamic brake or coast the motor to a stop (use the stopping method set in Pn001 (2001h) = n.□□□X).  |              |                 |                   |               |                |           |           |
|                                  | 2      |   | Set the stopping method with Pn00A (200Ah) = n.□□□X.   |              |                 |                   |               |                |           |           |
|                                  | n.□X□□ |   | Reserved parameter (Do not change.)  |              |                 |                   |               |                |           |           |
|                                  | n.X□□□ |   | Reserved parameter (Do not change.)  |              |                 |                   |               |                |           |           |

Continued on next page.

Continued from previous page.

| Parameter No.                    | Size   | Name                                | Setting Range                                    | Setting Unit                                     | Default Setting | Applicable Motors | When Enabled  | Classification | Reference         |            |  |
|----------------------------------|--------|-------------------------------------|--|--|-----------------|-------------------|---------------|----------------|-------------------|------------|--|
| Pn00C<br>(A: 200Ch,<br>B: 280Ch) | 2      | Application Function Selections C   | 0000h to 0131h                                   | -  | 0000h           | -                 | After restart | Setup          | page 8-21         |            |  |
|                                  | n.□□□X |                                     | Function Selection for Test without a Motor      |  |                 |                   |               |                | Applicable Motors |            |  |
|                                  |        |                                     | 0  | Disable tests without a motor.                   |                 |                   |               |                |                   | All        |  |
|                                  |        |                                     | 1  | Enable tests without a motor.                    |                 |                   |               |                |                   |            |  |
|                                  | n.□□□□ |                                     | Encoder Resolution for Tests without a Motor     |  |                 |                   |               |                | Applicable Motors |            |  |
|                                  |        |                                     | 0  | Use 13 bits.                                     |                 |                   |               |                |                   | Rotary     |  |
|                                  |        |                                     | 1  | Use 20 bits.                                     |                 |                   |               |                |                   |            |  |
|                                  |        |                                     | 2  | Use 22 bits.                                     |                 |                   |               |                |                   |            |  |
|                                  |        |                                     | 3  | Use 24 bits.                                     |                 |                   |               |                |                   |            |  |
|                                  | n.□X□□ |                                     | Encoder Type Selection for Tests without a Motor |  |                 |                   |               |                | Applicable Motors |            |  |
|                                  |        | 0                                   | Use an incremental encoder.                      |  |                 |                   |               |                | All               |            |  |
|                                  |        | 1                                   | Use an absolute encoder.                         |  |                 |                   |               |                |                   |            |  |
| n.X□□□                           |        | Reserved parameter (Do not change.) |  |  |                 |                   |               |                |                   |            |  |
| Pn00D<br>(A: 200Dh,<br>B: 280Dh) | 2      | Application Function Selections D   | 0000h to 2001h                                   | -  | 0000h           | All               | Immediately   | Setup          | page 6-28         |            |  |
|                                  | n.□□□X |                                     | Reserved parameter (Do not change.)              |  |                 |                   |               |                |                   |            |  |
|                                  | n.□□X□ |                                     | Reserved parameter (Do not change.)              |  |                 |                   |               |                |                   |            |  |
|                                  | n.□X□□ |                                     | Reserved parameter (Do not change.)              |  |                 |                   |               |                |                   |            |  |
|                                  | n.X□□□ |                                     | Overtravel Warning Detection Selection           |  |                 |                   |               |                |                   |            |  |
|                                  |        |                                     | 0  | Do not detect overtravel warnings.               |                 |                   |               |                |                   |            |  |
|                                  |        |                                     | 1  | Detect overtravel warnings.                      |                 |                   |               |                |                   |            |  |
|                                  |        | 2                                   | Reserved parameter (Do not change.)              |  |                 |                   |               |                |                   |            |  |
| Pn00F<br>(200Fh)<br>Common       | 2      | Application Function Selections F   | 0000h to 2011h                                   | -  | 0000h           | All               | After restart | Setup          | -                 |            |  |
|                                  | n.□□□X |                                     | Preventative Maintenance Warning Selection       |  |                 |                   |               |                | Reference         |            |  |
|                                  |        |                                     | 0  | Do not detect preventative maintenance warnings. |                 |                   |               |                |                   | page 10-15 |  |
|                                  |        |                                     | 1  | Detect preventative maintenance warnings.        |                 |                   |               |                |                   |            |  |
|                                  | n.□□X□ |                                     | Reserved parameter (Do not change.)              |  |                 |                   |               |                |                   |            |  |
|                                  | n.□X□□ |                                     | Reserved parameter (Do not change.)              |  |                 |                   |               |                |                   |            |  |
| n.X□□□                           |        | Reserved parameter (Do not change.) |  |  |                 |                   |               |                |                   |            |  |

Continued on next page.

16.1 List of Servo Parameters

16.1.2 List of Parameters

Continued from previous page.

| Parameter No.                    | Size   | Name   | Setting Range                                    | Setting Unit | Default Setting | Applicable Motors | When Enabled  | Classification | Reference |            |
|----------------------------------|--|--|--|--------------|-----------------|-------------------|---------------|----------------|-----------|------------|
| Pn022<br>(A: 2022h,<br>B: 2822h) | 2  | Application Function Selections 22   | 0000h to 0011h                                   | -            | 0000h           | All               | After restart | Setup          | -         |            |
|                                  | n.□□□X   |  | Overtravel Release Method Selection              |              |                 |                   |               |                | Reference | page 6-29  |
|                                  | 0  | Overtravel exists while the P-OT or N-OT signal is being input.  |  |              |                 |                   |               |                |           |            |
|                                  | 1  | Overtravel exists while the P-OT or N-OT signal is input and the current position of the workpiece is separated from the P-OT signal or N-OT signal. |  |              |                 |                   |               |                |           |            |
|                                  | n.□□X□   |  | Reserved parameter (Do not change.)              |              |                 |                   |               |                |           |            |
|                                  | n.□X□□   |  | Reserved parameter (Do not change.)              |              |                 |                   |               |                |           |            |
| n.X□□□                           |  | Reserved parameter (Do not change.)  |  |              |                 |                   |               |                |           |            |
| Pn023<br>(2023h)<br>Common       | 2  | Application Function Selections 23   | 0000h to 0011h                                   | -            | 0000h           | All               | After restart | Setup          | -         |            |
|                                  | n.□□□X   |  | Built-in Brake Relay Usage Selection             |              |                 |                   |               |                | Reference | page 6-35  |
|                                  | 0  | Use the built-in brake relay.  |  |              |                 |                   |               |                |           |            |
|                                  | 1  | Do not use the built-in brake relay.   |  |              |                 |                   |               |                |           |            |
|                                  | n.□□X□   |  | Built-in Brake Relay Life Alarm Enable Selection |              |                 |                   |               |                | Reference | page 10-15 |
|                                  | 0  | Detect built-in brake relay life alarm.  |  |              |                 |                   |               |                |           |            |
| 1                                | Do not detect built-in brake relay life alarm.         |  |  |              |                 |                   |               |                |           |            |
| n.□X□□                           |  | Reserved parameter (Do not change.)  |  |              |                 |                   |               |                |           |            |
| n.X□□□                           |  | Reserved parameter (Do not change.)  |  |              |                 |                   |               |                |           |            |
| Pn07F<br>(A: 207Fh,<br>B: 287Fh) | 2  | Reserved parameter (Do not change.)  | 0000h to 0002h                                   | -            | 0000h           | -                 | -             | -              | -         |            |
| Pn080<br>(A: 2080h,<br>B: 2880h) | 2  | Application Function Selections 80   | 0000h to 1111h                                   | -            | 0000h           | Linear            | After restart | Setup          | -         |            |
|                                  | n.□□□X   |  | Polarity Sensor Selection                        |              |                 |                   |               |                | Reference | page 6-21  |
|                                  | 0  | Use polarity sensor.   |  |              |                 |                   |               |                |           |            |
|                                  | 1  | Do not use polarity sensor.  |  |              |                 |                   |               |                |           |            |
|                                  | n.□□X□   |  | Motor Phase Sequence Selection                   |              |                 |                   |               |                | Reference | page 6-19  |
|                                  | 0  | Set a phase-A lead as a phase sequence of U, V, and W.   |  |              |                 |                   |               |                |           |            |
| 1                                | Set a phase-B lead as a phase sequence of U, V, and W. |  |  |              |                 |                   |               |                |           |            |
| n.□X□□                           |  | Reserved parameter (Do not change.)  |  |              |                 |                   |               |                |           |            |
| n.X□□□                           |  | Reserved parameter (Do not change.)  |  |              |                 |                   |               |                |           |            |
| Pn100<br>(A: 2100h,<br>B: 2900h) | 2  | Speed Loop Gain  | 10 to 20,000                                     | 0.1 Hz       | 400             | All               | Immediately   | Tuning         | page 9-77 |            |
| Pn101<br>(A: 2101h,<br>B: 2901h) | 2  | Speed Loop Integral Time Constant  | 15 to 51,200                                     | 0.01 ms      | 2000            | All               | Immediately   | Tuning         | page 9-77 |            |
| Pn102<br>(A: 2102h,<br>B: 2902h) | 2  | Position Loop Gain   | 10 to 20,000                                     | 0.1/s        | 400             | All               | Immediately   | Tuning         | page 9-77 |            |
| Pn103<br>(A: 2103h,<br>B: 2903h) | 2  | Moment of Inertia Ratio  | 0 to 20,000                                      | 1%           | 100             | All               | Immediately   | Tuning         | page 9-77 |            |

Continued on next page.



Continued from previous page.

| Parameter No.                    | Size                                | Name  | Setting Range  | Setting Unit           | Default Setting | Applicable Motors | When Enabled  | Classification | Reference            |           |
|----------------------------------|-------------------------------------|---|--|------------------------|-----------------|-------------------|---------------|----------------|----------------------|-----------|
| Pn104<br>(A: 2104h,<br>B: 2904h) | 2                                   | Second Speed Loop Gain  | 10 to 20,000   | 0.1 Hz                 | 400             | All               | Immediately   | Tuning         | page 9-65            |           |
| Pn105<br>(A: 2105h,<br>B: 2905h) | 2                                   | Second Speed Loop Integral Time Constant                                    | 15 to 51,200   | 0.01 ms                | 2000            | All               | Immediately   | Tuning         | page 9-65            |           |
| Pn106<br>(A: 2106h,<br>B: 2906h) | 2                                   | Second Position Loop Gain   | 10 to 20,000   | 0.1/s                  | 400             | All               | Immediately   | Tuning         | page 9-65            |           |
| Pn109<br>(A: 2109h,<br>B: 2909h) | 2                                   | Feedforward   | 0 to 100   | 1%                     | 0               | All               | Immediately   | Tuning         | page 9-87            |           |
| Pn10A<br>(A: 210Ah,<br>B: 290Ah) | 2                                   | Feedforward Filter Time Constant  | 0 to 6,400   | 0.01 ms                | 0               | All               | Immediately   | Tuning         | page 9-87            |           |
| Pn10B<br>(A: 210Bh,<br>B: 290Bh) | 2                                   | Gain Application Selections   | 0000h to 5334h   | -                      | 0000h           | All               | -             | Setup          | -                    |           |
|                                  | n.□□□X                              | Mode Switching Selection  |  |                        |                 |                   |               | When Enabled   | Reference            | page 9-88 |
|                                  |                                     | 0   | Use the internal torque reference as the condition (level setting: Pn10C (210Ch)). |                        |                 |                   |               | Immediately    |                      |           |
|                                  |                                     | 1   | Use the speed reference as the condition (level setting: Pn10D (210Dh)).           |                        |                 |                   |               |                |                      |           |
|                                  |                                     |   | Use the speed reference as the condition (level setting: Pn181 (2181h)).           |                        |                 |                   |               |                |                      |           |
|                                  |                                     | 2   | Use the acceleration reference as the condition (level setting: Pn10E (210Eh)).    |                        |                 |                   |               |                |                      |           |
|                                  |                                     |   | Use the acceleration reference as the condition (level setting: Pn182 (2182h)).    |                        |                 |                   |               |                |                      |           |
|                                  | 3                                   | Use the position deviation as the condition (level setting: Pn10F (210Fh)). |  |                        |                 |                   |               |                |                      |           |
|                                  | 4                                   | Do not use mode switching.  |  |                        |                 |                   |               |                |                      |           |
|                                  | n.□□X□                              | Speed Loop Control Method   |  |                        |                 |                   |               | When Enabled   | Reference            |           |
| 0                                |                                     | PI control  |  |                        |                 |                   | After restart | page 9-77      |                      |           |
| 1                                |                                     | I-P control   |  |                        |                 |                   |               |                |                      |           |
| 2 and 3                          |                                     | Reserved parameters (Do not change.)  |  |                        |                 |                   |               |                |                      |           |
| n.□X□□                           | Reserved parameter (Do not change.) |   |  |                        |                 |                   |               |                |                      |           |
| n.X□□□                           | Reserved parameter (Do not change.) |   |  |                        |                 |                   |               |                |                      |           |
| Pn10C<br>(A: 210Ch,<br>B: 290Ch) | 2                                   | Mode Switching Level for Torque Reference                                   | 0 to 800   | 1%                     | 200             | All               | Immediately   | Tuning         | page 9-88            |           |
| Pn10D<br>(A: 210Dh,<br>B: 290Dh) | 2                                   | Mode Switching Level for Speed Reference                                    | 0 to 10,000  | 1 min <sup>-1</sup>    | 0               | Rotary            | Immediately   | Tuning         | page 9-88            |           |
| Pn10E<br>(A: 210Eh,<br>B: 290Eh) | 2                                   | Mode Switching Level for Acceleration                                       | 0 to 30,000  | 1 min <sup>-1</sup> /s | 0               | Rotary            | Immediately   | Tuning         | page 9-88            |           |
| Pn10F<br>(A: 210Fh,<br>B: 290Fh) | 2                                   | Mode Switching Level for Position Deviation                                 | 0 to 10,000  | 1 reference unit       | 0               | All               | Immediately   | Tuning         | page 9-88            |           |
| Pn11F<br>(A: 211Fh,<br>B: 291Fh) | 2                                   | Position Integral Time Constant   | 0 to 50,000  | 0.1 ms                 | 0               | All               | Immediately   | Tuning         | page 9-90            |           |
| Pn121<br>(A: 2121h,<br>B: 2921h) | 2                                   | Friction Compensation Gain  | 10 to 1,000  | 1%                     | 100             | All               | Immediately   | Tuning         | page 9-65, page 9-68 |           |

Continued on next page.

16.1 List of Servo Parameters

16.1.2 List of Parameters

Continued from previous page.

| Parameter No.                    | Size   | Name                                       | Setting Range  | Setting Unit  | Default Setting | Applicable Motors | When Enabled | Classification | Reference               |  |
|----------------------------------|--------|--|--|---|-----------------|-------------------|--------------|----------------|-------------------------|--|
| Pn122<br>(A: 2122h,<br>B: 2922h) | 2      | Second Friction Compensation Gain          | 10 to 1,000  | 1%  | 100             | All               | Immediately  | Tuning         | page 9-65,<br>page 9-68 |  |
| Pn123<br>(A: 2123h,<br>B: 2923h) | 2      | Friction Compensation Coefficient          | 0 to 100   | 1%  | 0               | All               | Immediately  | Tuning         | page 9-68               |  |
| Pn124<br>(A: 2124h,<br>B: 2924h) | 2      | Friction Compensation Frequency Correction | -10,000 to 10,000  | 0.1 Hz  | 0               | All               | Immediately  | Tuning         | page 9-68               |  |
| Pn125<br>(A: 2125h,<br>B: 2925h) | 2      | Friction Compensation Gain Correction      | 1 to 1,000   | 1%  | 100             | All               | Immediately  | Tuning         | page 9-68               |  |
| Pn131<br>(A: 2131h,<br>B: 2931h) | 2      | Gain Switching Time 1                      | 0 to 65,535  | 1 ms  | 0               | All               | Immediately  | Tuning         | page 9-65               |  |
| Pn132<br>(A: 2132h,<br>B: 2932h) | 2      | Gain Switching Time 2                      | 0 to 65,535  | 1 ms  | 0               | All               | Immediately  | Tuning         | page 9-65               |  |
| Pn135<br>(A: 2135h,<br>B: 2935h) | 2      | Gain Switching Waiting Time 1              | 0 to 65,535  | 1 ms  | 0               | All               | Immediately  | Tuning         | page 9-65               |  |
| Pn136<br>(A: 2136h,<br>B: 2936h) | 2      | Gain Switching Waiting Time 2              | 0 to 65,535  | 1 ms  | 0               | All               | Immediately  | Tuning         | page 9-65               |  |
| Pn139<br>(A: 2139h,<br>B: 2939h) | 2      | Automatic Gain Switching Selections 1      | 0000h to 0052h   | -   | 0000h           | All               | Immediately  | Tuning         | page 9-65               |  |
|                                  | n.□□□X |  | <b>Gain Switching Selection</b>  |   |                 |                   |              |                |                         |  |
|                                  |        |  | 0  | Disable automatic gain switching.   |                 |                   |              |                |                         |  |
|                                  |        |  | 1  | Reserved parameter (Do not change.)   |                 |                   |              |                |                         |  |
|                                  |        |  | 2  | Use automatic gain switching pattern 1. The gain settings 1 switch automatically to 2 when switching condition A is satisfied. The gain settings 2 switch automatically to 1 when switching condition A is not satisfied. |                 |                   |              |                |                         |  |
|                                  | n.□□□□ |  | <b>Gain Switching Condition A</b>  |   |                 |                   |              |                |                         |  |
|                                  |        |  | 0  | /COIN (Positioning Completion Output) signal turns ON.  |                 |                   |              |                |                         |  |
|                                  |        |  | 1  | /COIN (Positioning Completion Output) signal turns OFF.   |                 |                   |              |                |                         |  |
|                                  |        |  | 2  | /NEAR (Near Output) signal turns ON.  |                 |                   |              |                |                         |  |
|                                  |        |  | 3  | /NEAR (Near Output) signal turns OFF.   |                 |                   |              |                |                         |  |
|                                  |        | 4  | Position reference filter output is 0 and position reference input is OFF. |   |                 |                   |              |                |                         |  |
|                                  |        | 5  | Position reference input is ON.  |   |                 |                   |              |                |                         |  |
| n.□□□□                           |        | Reserved parameter (Do not change.)        |  |   |                 |                   |              |                |                         |  |
| n.X□□□                           |        | Reserved parameter (Do not change.)        |  |   |                 |                   |              |                |                         |  |
| Pn13D<br>(A: 213Dh,<br>B: 293Dh) | 2      | Current Gain Level                         | 100 to 2,000   | 1%  | 2000            | All               | Immediately  | Tuning         | page 9-71               |  |

Continued on next page.

Continued from previous page.

| Parameter No.                    | Size                             | Name   | Setting Range  | Setting Unit  | Default Setting | Applicable Motors | When Enabled | Classification | Reference |           |  |
|----------------------------------|----------------------------------|--|--|---|-----------------|-------------------|--------------|----------------|-----------|-----------|--|
| Pn140<br>(A: 2140h,<br>B: 2940h) | 2                                | Model Following Control-Related Selections             | 0000h to 1121h   | –   | 0100h           | All               | Immediately  | Tuning         | –         |           |  |
|                                  | n.□□□X                           |  | Model Following Control Selection                          |   |                 |                   |              |                | Reference |           |  |
|                                  |                                  |  | 0  | Do not use model following control.   |                 |                   |              |                |           | page 9-77 |  |
|                                  |                                  |  | 1  | Use model following control.  |                 |                   |              |                |           |           |  |
|                                  | n.□□X□                           |  | Vibration Suppression Selection                            |   |                 |                   |              |                | Reference |           |  |
|                                  |                                  |  | 0  | Do not perform vibration suppression.   |                 |                   |              |                |           | page 9-77 |  |
|                                  |                                  |  | 1  | Perform vibration suppression for a specific frequency.   |                 |                   |              |                |           |           |  |
|                                  |                                  |  | 2  | Perform vibration suppression for two specific frequencies.   |                 |                   |              |                |           |           |  |
|                                  | n.□X□□                           |  | Vibration Suppression Adjustment Selection                 |   |                 |                   |              |                | Reference |           |  |
|                                  |                                  |  | 0  | Do not adjust vibration suppression automatically during execution of autotuning without a host reference, autotuning with a host reference, and custom tuning. |                 |                   |              |                |           | page 9-31 |  |
|                                  |                                  |  | 1  | Adjust vibration suppression automatically during execution of autotuning without a host reference, autotuning with a host reference, and custom tuning.        |                 |                   |              |                |           |           |  |
|                                  | n.X□□□                           |  | Speed Feedforward (VFF)/Torque Feedforward (TFF) Selection |   |                 |                   |              |                | Reference |           |  |
|                                  |                                  |  | 0  | Do not use model following control and speed/torque feedforward together.   |                 |                   |              |                |           | page 9-31 |  |
|                                  |                                  |  | 1  | Use model following control and speed/torque feedforward together.  |                 |                   |              |                |           |           |  |
|                                  | Pn141<br>(A: 2141h,<br>B: 2941h) | 2  | Model Following Control Gain                               | 10 to 20,000  | 0.1/s           | 500               | All          | Immediately    | Tuning    | page 9-77 |  |
|                                  | Pn142<br>(A: 2142h,<br>B: 2942h) | 2  | Model Following Control Gain Correction                    | 500 to 2,000  | 0.1%            | 1000              | All          | Immediately    | Tuning    | page 9-65 |  |
| Pn143<br>(A: 2143h,<br>B: 2943h) | 2                                | Model Following Control Bias in the Forward Direction  | 0 to 10,000  | 0.1%  | 1000            | All               | Immediately  | Tuning         | page 9-77 |           |  |
| Pn144<br>(A: 2144h,<br>B: 2944h) | 2                                | Model Following Control Bias in the Reverse Direction  | 0 to 10,000  | 0.1%  | 1000            | All               | Immediately  | Tuning         | page 9-77 |           |  |
| Pn145<br>(A: 2145h,<br>B: 2945h) | 2                                | Vibration Suppression 1 Frequency A                    | 10 to 2,500  | 0.1 Hz  | 500             | All               | Immediately  | Tuning         | page 9-55 |           |  |
| Pn146<br>(A: 2146h,<br>B: 2946h) | 2                                | Vibration Suppression 1 Frequency B                    | 10 to 2,500  | 0.1 Hz  | 700             | All               | Immediately  | Tuning         | page 9-55 |           |  |
| Pn147<br>(A: 2147h,<br>B: 2947h) | 2                                | Model Following Control Speed Feedforward Compensation | 0 to 10,000  | 0.1%  | 1000            | All               | Immediately  | Tuning         | page 9-77 |           |  |
| Pn148<br>(A: 2148h,<br>B: 2948h) | 2                                | Second Model Following Control Gain                    | 10 to 20,000   | 0.1/s   | 500             | All               | Immediately  | Tuning         | page 9-65 |           |  |
| Pn149<br>(A: 2149h,<br>B: 2949h) | 2                                | Second Model Following Control Gain Correction         | 500 to 2,000   | 0.1%  | 1000            | All               | Immediately  | Tuning         | page 9-65 |           |  |
| Pn14A<br>(A: 214Ah,<br>B: 294Ah) | 2                                | Vibration Suppression 2 Frequency                      | 10 to 2,000  | 0.1 Hz  | 800             | All               | Immediately  | Tuning         | page 9-55 |           |  |
| Pn14B<br>(A: 214Bh,<br>B: 294Bh) | 2                                | Vibration Suppression 2 Correction                     | 10 to 1,000  | 1%  | 100             | All               | Immediately  | Tuning         | page 9-55 |           |  |

Continued on next page.

16.1 List of Servo Parameters

16.1.2 List of Parameters

Continued from previous page.

| Parameter No.                    | Size                             | Name   | Setting Range                               | Setting Unit   | Default Setting | Applicable Motors | When Enabled  | Classification | Reference |           |  |
|----------------------------------|----------------------------------|--|---|--|-----------------|-------------------|---------------|----------------|-----------|-----------|--|
| Pn14F<br>(A: 214Fh,<br>B: 294Fh) | 2                                | Control-Related Selections                       | 0000h to 0021h                              | -  | 0021h           | All               | After restart | Tuning         | -         |           |  |
|                                  | n.□□□X                           |  | Model Following Control Type Selection      |  |                 |                   |               |                | Reference |           |  |
|                                  |                                  |  | 0   | Use model following control type 1.  |                 |                   |               |                |           | page 9-87 |  |
|                                  |                                  |  | 1   | Use model following control type 2.  |                 |                   |               |                |           |           |  |
|                                  | n.□□□□                           |  | Tuning-less Type Selection                  |  |                 |                   |               |                | Reference |           |  |
|                                  |                                  |  | 0   | Use tuning-less type 1.  |                 |                   |               |                |           | page 9-13 |  |
|                                  |                                  |  | 1   | Use tuning-less type 2.  |                 |                   |               |                |           |           |  |
|                                  |                                  |  | 2   | Use tuning-less type 3.  |                 |                   |               |                |           |           |  |
|                                  | n.□X□□                           |  | Reserved parameter (Do not change.)         |  |                 |                   |               |                |           |           |  |
|                                  | n.X□□□                           |  | Reserved parameter (Do not change.)         |  |                 |                   |               |                |           |           |  |
| Pn160<br>(A: 2160h,<br>B: 2960h) | 2                                | Anti-Resonance Control-Related Selections        | 0000h to 0011h                              | -  | 0010h           | All               | Immediately   | Tuning         | -         |           |  |
|                                  | n.□□□X                           |  | Anti-Resonance Control Selection            |  |                 |                   |               |                | Reference |           |  |
|                                  |                                  |  | 0   | Do not use anti-resonance control.   |                 |                   |               |                |           | page 9-50 |  |
|                                  |                                  |  | 1   | Use anti-resonance control.  |                 |                   |               |                |           |           |  |
|                                  | n.□□□□                           |  | Anti-Resonance Control Adjustment Selection |  |                 |                   |               |                | Reference |           |  |
|                                  |                                  |  | 0   | Do not adjust anti-resonance control automatically during execution of autotuning without a host reference, autotuning with a host reference, and custom tuning. |                 |                   |               |                |           | page 9-31 |  |
|                                  |                                  |  | 1   | Adjust anti-resonance control automatically during execution of autotuning without a host reference, autotuning with a host reference, and custom tuning.        |                 |                   |               |                |           |           |  |
|                                  | n.□X□□                           |  | Reserved parameter (Do not change.)         |  |                 |                   |               |                |           |           |  |
|                                  | n.X□□□                           |  | Reserved parameter (Do not change.)         |  |                 |                   |               |                |           |           |  |
|                                  | Pn161<br>(A: 2161h,<br>B: 2961h) | 2  | Anti-Resonance Frequency                    | 10 to 20,000   | 0.1 Hz          | 1000              | All           | Immediately    | Tuning    | page 9-50 |  |
| Pn162<br>(A: 2162h,<br>B: 2962h) | 2                                | Anti-Resonance Gain Correction                   | 1 to 1,000                                  | 1%   | 100             | All               | Immediately   | Tuning         | page 9-50 |           |  |
| Pn163<br>(A: 2163h,<br>B: 2963h) | 2                                | Anti-Resonance Damping Gain                      | 0 to 300                                    | 1%   | 0               | All               | Immediately   | Tuning         | page 9-50 |           |  |
| Pn164<br>(A: 2164h,<br>B: 2964h) | 2                                | Anti-Resonance Filter Time Constant 1 Correction | -1,000 to 1,000                             | 0.01 ms  | 0               | All               | Immediately   | Tuning         | page 9-50 |           |  |
| Pn165<br>(A: 2165h,<br>B: 2965h) | 2                                | Anti-Resonance Filter Time Constant 2 Correction | -1,000 to 1,000                             | 0.01 ms  | 0               | All               | Immediately   | Tuning         | page 9-50 |           |  |
| Pn166<br>(A: 2166h,<br>B: 2966h) | 2                                | Anti-Resonance Damping Gain 2                    | 0 to 1,000                                  | 1%   | 0               | All               | Immediately   | Tuning         | page 9-50 |           |  |

Continued on next page.

Continued from previous page.

| Parameter No.                    | Size   | Name  | Setting Range  | Setting Unit   | Default Setting     | Applicable Motors | When Enabled  | Classification | Reference     |           |
|----------------------------------|--|---|--|----------------|---------------------|-------------------|---------------|----------------|---------------|-----------|
| Pn170<br>(A: 2170h,<br>B: 2970h) | 2  | Tuning-less Function-Related Selections                             | 0000h to 2711h   | –              | 1401h               | All               | –             | Setup          | page 9-12     |           |
|                                  | n.□□□X   | Tuning-less Selection   |  |                |                     |                   |               |                | When Enabled  |           |
|                                  |  | 0   | Disable tuning-less function.  |                |                     |                   |               |                | After restart |           |
|                                  | 1  | Enable tuning-less function.  |  |                |                     |                   |               |                |               |           |
|                                  | n.□□□□   | Speed Control Method  |  |                |                     |                   |               |                | When Enabled  |           |
|                                  |  | 0   | Use for speed control.   |                |                     |                   |               |                | After restart |           |
|                                  | 1  | Use for speed control and use host controller for position control. |  |                |                     |                   |               |                |               |           |
|                                  | n.□X□□   | Rigidity Level  |  |                |                     |                   |               |                | When Enabled  |           |
|                                  |  | 0 to 7  | Set the rigidity level.  |                |                     |                   |               |                | Immediately   |           |
|                                  | n.X□□□   | Tuning-less Load Level  |  |                |                     |                   |               |                | When Enabled  |           |
|                                  |  | 0 to 2  | Set the load level for the tuning-less function.   |                |                     |                   |               |                | Immediately   |           |
|                                  | Pn181<br>(A: 2181h,<br>B: 2981h)   | 2   | Mode Switching Level for Speed Reference   | 0 to 10,000    | 1 mm/s              | 0                 | Linear        | Immediately    | Tuning        | page 9-88 |
|                                  | Pn182<br>(A: 2182h,<br>B: 2982h)   | 2   | Mode Switching Level for Acceleration  | 0 to 30,000    | 1 mm/s <sup>2</sup> | 0                 | Linear        | Immediately    | Tuning        | page 9-88 |
|                                  | Pn205<br>(A: 2205h,<br>B: 2A05h)   | 2   | Multiturn Limit  | 0 to 65,535    | 1 rev               | 65535             | Rotary        | After restart  | Setup         | page 7-28 |
|                                  | Pn207<br>(A: 2207h,<br>B: 2A07h)   | 2   | Position Control Function Selections   | 0000h to 2210h | –                   | 0010h             | All           | After restart  | Setup         | –         |
|                                  |  | n.□□□X  | Reserved parameter (Do not change.)  |                |                     |                   |               |                |               |           |
| n.□□□□                           |  | Reserved parameter (Do not change.)                                 |  |                |                     |                   |               |                |               |           |
| n.□X□□                           |  | Reserved parameter (Do not change.)                                 |  |                |                     |                   |               |                |               |           |
| n.X□□□                           |  | /COIN (Positioning Completion Output) Signal Output Timing          |  |                |                     |                   |               |                | Reference     |           |
|                                  |  | 0   | Output when the absolute value of the position deviation is the same or less than the setting of Pn522 (2522h) (Positioning Completed Width).  |                |                     |                   |               |                | page 7-14     |           |
|                                  |  | 1   | Output when the absolute value of the position error is the same or less than the setting of Pn522 (2522h) (Positioning Completed Width) and the reference after the position reference filter is 0. |                |                     |                   |               |                |               |           |
| 2                                | Output when the absolute value of the position error is the same or less than the setting of Pn522 (2522h) (Positioning Completed Width) and the reference input is 0. |   |  |                |                     |                   |               |                |               |           |
| Pn20E<br>(A: 220Eh,<br>B: 2A0Eh) | 4  | Electronic Gear Ratio (Numerator) <sup>*4</sup>                     | 1 to 1,073,741,824   | 1              | 16                  | All               | After restart | Setup          | page 6-41     |           |
| Pn210<br>(A: 2210h,<br>B: 2A10h) | 4  | Electronic Gear Ratio (Denominator) <sup>*4</sup>                   | 1 to 1,073,741,824   | 1              | 1                   | All               | After restart | Setup          | page 6-41     |           |

Continued on next page.

16.1 List of Servo Parameters

16.1.2 List of Parameters

Continued from previous page.

| Parameter No.                    | Size   | Name   | Setting Range                          | Setting Unit                                       | Default Setting | Applicable Motors | When Enabled  | Classification | Reference |  |
|----------------------------------|--------|--|--|--|-----------------|-------------------|---------------|----------------|-----------|--|
| Pn230<br>(A: 2230h,<br>B: 2A30h) | 2      | Position Control Expansion Function Selections   | 0000h to 0001h                         | -  | 0000h           | All               | After restart | Setup          | page 9-72 |  |
|                                  | n.□□□X |  | <b>Backlash Compensation Direction</b> |  |                 |                   |               |                |           |  |
|                                  |        |  | 0                                      | Compensate forward references.                     |                 |                   |               |                |           |  |
|                                  |        |  | 1                                      | Compensate reverse references.                     |                 |                   |               |                |           |  |
|                                  | n.□□X□ |  | Reserved parameter (Do not change.)    |  |                 |                   |               |                |           |  |
|                                  | n.□X□□ |  | Reserved parameter (Do not change.)    |  |                 |                   |               |                |           |  |
| n.X□□□                           |        | Reserved parameter (Do not change.)              |  |  |                 |                   |               |                |           |  |
| Pn231<br>(A: 2231h,<br>B: 2A31h) | 4      | Backlash Compensation                            | -500,000 to 500,000                    | 0.1 reference units                                | 0               | All               | Immediately   | Setup          | page 9-72 |  |
| Pn233<br>(A: 2233h,<br>B: 2A33h) | 2      | Backlash Compensation Time Constant              | 0 to 65,535                            | 0.01 ms  | 0               | All               | Immediately   | Setup          | page 9-72 |  |
| Pn282<br>(A: 2282h,<br>B: 2A82h) | 4      | Linear Encoder Scale Pitch                       | 0 to 6,553,600                         | 0.01 μm  | 0               | Linear            | After restart | Setup          | page 6-14 |  |
| Pn304<br>(A: 2304h,<br>B: 2B04h) | 2      | Jogging Speed                                    | 0 to 10,000                            | 1 min <sup>-1</sup>                                | 500             | Rotary            | Immediately   | Setup          | page 8-7  |  |
| Pn305<br>(A: 2305h,<br>B: 2B05h) | 2      | Soft Start Acceleration Time                     | 0 to 10,000                            | 1 ms   | 0               | All               | Immediately   | Setup          | *1        |  |
| Pn306<br>(A: 2306h,<br>B: 2B06h) | 2      | Soft Start Deceleration Time                     | 0 to 10,000                            | 1 ms   | 0               | All               | Immediately   | Setup          | *1        |  |
| Pn308<br>(A: 2308h,<br>B: 2B08h) | 2      | Speed Feedback Filter Time Constant              | 0 to 65,535                            | 0.01 ms  | 0               | All               | Immediately   | Setup          | page 9-77 |  |
| Pn30A<br>(A: 230Ah,<br>B: 2B0Ah) | 2      | Deceleration Time for Servo OFF and Forced Stops | 0 to 10,000                            | 1 ms   | 0               | All               | Immediately   | Setup          | page 6-27 |  |
| Pn30C<br>(A: 230Ch,<br>B: 2B0Ch) | 2      | Speed Feedforward Average Movement Time          | 0 to 5,100                             | 0.1 ms   | 0               | All               | Immediately   | Setup          | page 9-87 |  |
| Pn310<br>(A: 2310h,<br>B: 2B10h) | 2      | Vibration Detection Selections                   | 0000h to 0002h                         | -  | 0000h           | All               | Immediately   | Setup          | page 7-37 |  |
|                                  | n.□□□X |  | <b>Vibration Detection Selection</b>   |  |                 |                   |               |                |           |  |
|                                  |        |  | 0                                      | Do not detect vibration.                           |                 |                   |               |                |           |  |
|                                  |        |  | 1                                      | Output a warning (A.911) if vibration is detected. |                 |                   |               |                |           |  |
|                                  |        |  | 2                                      | Output an alarm (A.520) if vibration is detected.  |                 |                   |               |                |           |  |
|                                  | n.□□X□ |  | Reserved parameter (Do not change.)    |  |                 |                   |               |                |           |  |
| n.□X□□                           |        | Reserved parameter (Do not change.)              |  |  |                 |                   |               |                |           |  |
| n.X□□□                           |        | Reserved parameter (Do not change.)              |  |  |                 |                   |               |                |           |  |
| Pn311<br>(A: 2311h,<br>B: 2B11h) | 2      | Vibration Detection Sensitivity                  | 50 to 500                              | 1%   | 100             | All               | Immediately   | Tuning         | page 7-37 |  |
| Pn312<br>(A: 2312h,<br>B: 2B12h) | 2      | Vibration Detection Level                        | 0 to 5,000                             | 1 min <sup>-1</sup>                                | 50              | Rotary            | Immediately   | Tuning         | page 7-37 |  |

Continued on next page.

Continued from previous page.

| Parameter No.                    | Size | Name  | Setting Range | Setting Unit        | Default Setting | Applicable Motors | When Enabled  | Classification | Reference |
|----------------------------------|------|---|---------------|---------------------|-----------------|-------------------|---------------|----------------|-----------|
| Pn316<br>(A: 2316h,<br>B: 2B16h) | 2    | Maximum Motor Speed                                     | 0 to 65,535   | 1 min <sup>-1</sup> | 10000           | Rotary            | After restart | Setup          | page 7-21 |
| Pn324<br>(A: 2324h,<br>B: 2B24h) | 2    | Moment of Inertia Calculation Starting Level            | 0 to 20,000   | 1%                  | 300             | All               | Immediately   | Setup          | page 9-31 |
| Pn383<br>(A: 2383h,<br>B: 2B83h) | 2    | Jogging Speed   | 0 to 10,000   | 1 mm/s              | 50              | Linear            | Immediately   | Setup          | page 8-7  |
| Pn384<br>(A: 2384h,<br>B: 2B84h) | 2    | Vibration Detection Level                               | 0 to 5,000    | 1 mm/s              | 10              | Linear            | Immediately   | Tuning         | page 7-37 |
| Pn385<br>(A: 2385h,<br>B: 2B85h) | 2    | Maximum Motor Speed                                     | 1 to 100      | 100 mm/s            | 50              | Linear            | After restart | Setup          | page 7-21 |
| Pn401<br>(A: 2401h,<br>B: 2C01h) | 2    | First Stage First Torque Reference Filter Time Constant | 0 to 65,535   | 0.01 ms             | 100             | All               | Immediately   | Tuning         | page 9-80 |
| Pn402<br>(A: 2402h,<br>B: 2C02h) | 2    | Forward Torque Limit                                    | 0 to 800      | 1%*1                | 800             | Rotary            | Immediately   | Setup          | page 7-23 |
| Pn403<br>(A: 2403h,<br>B: 2C03h) | 2    | Reverse Torque Limit                                    | 0 to 800      | 1%*1                | 800             | Rotary            | Immediately   | Setup          | page 7-23 |
| Pn404<br>(A: 2404h,<br>B: 2C04h) | 2    | Forward External Torque Limit                           | 0 to 800      | 1%*1                | 100             | All               | Immediately   | Setup          | page 7-24 |
| Pn405<br>(A: 2405h,<br>B: 2C05h) | 2    | Reverse External Torque Limit                           | 0 to 800      | 1%*1                | 100             | All               | Immediately   | Setup          | page 7-24 |
| Pn406<br>(A: 2406h,<br>B: 2C06h) | 2    | Emergency Stop Torque                                   | 0 to 800      | 1%*1                | 800             | All               | Immediately   | Setup          | page 6-26 |
| Pn407<br>(A: 2407h,<br>B: 2C07h) | 2    | Speed Limit during Torque Control                       | 0 to 10,000   | 1 min <sup>-1</sup> | 10000           | Rotary            | Immediately   | Setup          | page 7-17 |

Continued on next page.

16.1 List of Servo Parameters

16.1.2 List of Parameters

Continued from previous page.

| Parameter No.                    | Size   | Name   | Setting Range                            | Setting Unit  | Default Setting | Applicable Motors | When Enabled  | Classification | Reference |  |
|----------------------------------|--------|--|--|---|-----------------|-------------------|---------------|----------------|-----------|--|
| Pn408<br>(A: 2408h,<br>B: 2C08h) | 2      | Torque-Related Function Selections                       | 0000h to 1111h                           | -   | 0000h           | All               | -             | Setup          | -         |  |
|                                  | n.□□□X |  | Notch Filter Selection 1                 |   |                 |                   | When Enabled  | Reference      |           |  |
|                                  |        |  | 0  | Disable first stage notch filter.   |                 |                   | Immediately   | page 9-80      |           |  |
|                                  |        |  | 1  | Enable first stage notch filter.  |                 |                   |               |                |           |  |
|                                  | n.□□□□ |  | Speed Limit Selection                    |   |                 |                   | When Enabled  | Reference      |           |  |
|                                  |        |  | 0  | Use the smaller of the maximum motor speed and the setting of Pn407 (2407h) as the speed limit.             |                 |                   | After restart | page 7-16      |           |  |
|                                  |        |  |  | Use the smaller of the maximum motor speed and the setting of Pn480 (2480h) as the speed limit.             |                 |                   |               |                |           |  |
|                                  |        |  | 1  | Use the smaller of the overspeed alarm detection speed and the setting of Pn407 (2407h) as the speed limit. |                 |                   |               |                |           |  |
|                                  |        |  |  | Use the smaller of the overspeed alarm detection speed and the setting of Pn480 (2480h) as the speed limit. |                 |                   |               |                |           |  |
|                                  | n.□X□□ |  | Notch Filter Selection 2                 |   |                 |                   | When Enabled  | Reference      |           |  |
|                                  |        |  | 0  | Disable second stage notch filter.  |                 |                   | Immediately   | page 9-80      |           |  |
|                                  |        |  | 1  | Enable second stage notch filter.   |                 |                   |               |                |           |  |
|                                  | n.X□□□ |  | Friction Compensation Function Selection |   |                 |                   | When Enabled  | Reference      |           |  |
|                                  |        |  | 0  | Disable friction compensation.  |                 |                   | Immediately   | page 9-68      |           |  |
|                                  |        |  | 1  | Enable friction compensation.   |                 |                   |               |                |           |  |
| Pn409<br>(A: 2409h,<br>B: 2C09h) | 2      | First Stage Notch Filter Frequency                       | 50 to 5,000                              | 1 Hz  | 5000            | All               | Immediately   | Tuning         | page 9-80 |  |
| Pn40A<br>(A: 240Ah,<br>B: 2C0Ah) | 2      | First Stage Notch Filter Q Value                         | 50 to 1,000                              | 0.01  | 70              | All               | Immediately   | Tuning         | page 9-80 |  |
| Pn40B<br>(A: 240Bh,<br>B: 2C0Bh) | 2      | First Stage Notch Filter Depth                           | 0 to 1,000                               | 0.001   | 0               | All               | Immediately   | Tuning         | page 9-80 |  |
| Pn40C<br>(A: 240Ch,<br>B: 2C0Ch) | 2      | Second Stage Notch Filter Frequency                      | 50 to 5,000                              | 1 Hz  | 5000            | All               | Immediately   | Tuning         | page 9-80 |  |
| Pn40D<br>(A: 240Dh,<br>B: 2C0Dh) | 2      | Second Stage Notch Filter Q Value                        | 50 to 1,000                              | 0.01  | 70              | All               | Immediately   | Tuning         | page 9-80 |  |
| Pn40E<br>(A: 240Eh,<br>B: 2C0Eh) | 2      | Second Stage Notch Filter Depth                          | 0 to 1,000                               | 0.001   | 0               | All               | Immediately   | Tuning         | page 9-80 |  |
| Pn40F<br>(A: 240Fh,<br>B: 2C0Fh) | 2      | Second Stage Second Torque Reference Filter Frequency    | 100 to 5,000                             | 1 Hz  | 5000            | All               | Immediately   | Tuning         | page 9-80 |  |
| Pn410<br>(A: 2410h,<br>B: 2C10h) | 2      | Second Stage Second Torque Reference Filter Q Value      | 50 to 100                                | 0.01  | 50              | All               | Immediately   | Tuning         | page 9-80 |  |
| Pn412<br>(A: 2412h,<br>B: 2C12h) | 2      | First Stage Second Torque Reference Filter Time Constant | 0 to 65,535                              | 0.01 ms   | 100             | All               | Immediately   | Tuning         | page 9-65 |  |

Continued on next page.



Continued from previous page.

| Parameter No.                    | Size          | Name                                 | Setting Range                              | Setting Unit                       | Default Setting | Applicable Motors | When Enabled | Classification | Reference |  |
|----------------------------------|---------------|--------------------------------------|--|------------------------------------|-----------------|-------------------|--------------|----------------|-----------|--|
| Pn416<br>(A: 2416h,<br>B: 2C16h) | 2             | Torque-Related Function Selections 2 | 0000h to 1111h                             | –                                  | 0000h           | All               | Immediately  | Setup          | page 9-82 |  |
|                                  |               | <b>n.□□□X</b>                        |  | <b>Notch Filter Selection 3</b>    |                 |                   |              |                |           |  |
|                                  |               |                                      | 0  | Disable third stage notch filter.  |                 |                   |              |                |           |  |
|                                  |               |                                      | 1  | Enable third stage notch filter.   |                 |                   |              |                |           |  |
|                                  |               | <b>n.□□X□</b>                        |  | <b>Notch Filter Selection 4</b>    |                 |                   |              |                |           |  |
|                                  |               |                                      | 0  | Disable fourth stage notch filter. |                 |                   |              |                |           |  |
|                                  |               |                                      | 1  | Enable fourth stage notch filter.  |                 |                   |              |                |           |  |
|                                  |               | <b>n.□X□□</b>                        |  | <b>Notch Filter Selection 5</b>    |                 |                   |              |                |           |  |
|                                  |               |                                      | 0  | Disable fifth stage notch filter.  |                 |                   |              |                |           |  |
|                                  |               |                                      | 1  | Enable fifth stage notch filter.   |                 |                   |              |                |           |  |
|                                  | <b>n.X□□□</b> |                                      | <b>Reserved parameter (Do not change.)</b> |                                    |                 |                   |              |                |           |  |
| Pn417<br>(A: 2417h,<br>B: 2C17h) | 2             | Third Stage Notch Filter Frequency   | 50 to 5,000                                | 1 Hz                               | 5000            | All               | Immediately  | Tuning         | page 9-82 |  |
| Pn418<br>(A: 2418h,<br>B: 2C18h) | 2             | Third Stage Notch Filter Q Value     | 50 to 1,000                                | 0.01                               | 70              | All               | Immediately  | Tuning         | page 9-82 |  |
| Pn419<br>(A: 2419h,<br>B: 2C19h) | 2             | Third Stage Notch Filter Depth       | 0 to 1,000                                 | 0.001                              | 0               | All               | Immediately  | Tuning         | page 9-82 |  |
| Pn41A<br>(A: 241Ah,<br>B: 2C1Ah) | 2             | Fourth Stage Notch Filter Frequency  | 50 to 5,000                                | 1 Hz                               | 5000            | All               | Immediately  | Tuning         | page 9-82 |  |
| Pn41B<br>(A: 241Bh,<br>B: 2C1Bh) | 2             | Fourth Stage Notch Filter Q Value    | 50 to 1,000                                | 0.01                               | 70              | All               | Immediately  | Tuning         | page 9-82 |  |
| Pn41C<br>(A: 241Ch,<br>B: 2C1Ch) | 2             | Fourth Stage Notch Filter Depth      | 0 to 1,000                                 | 0.001                              | 0               | All               | Immediately  | Tuning         | page 9-82 |  |
| Pn41D<br>(A: 241Dh,<br>B: 2C1Dh) | 2             | Fifth Stage Notch Filter Frequency   | 50 to 5,000                                | 1 Hz                               | 5000            | All               | Immediately  | Tuning         | page 9-82 |  |
| Pn41E<br>(A: 241Eh,<br>B: 2C1Eh) | 2             | Fifth Stage Notch Filter Q Value     | 50 to 1,000                                | 0.01                               | 70              | All               | Immediately  | Tuning         | page 9-82 |  |
| Pn41F<br>(A: 241Fh,<br>B: 2C1Fh) | 2             | Fifth Stage Notch Filter Depth       | 0 to 1,000                                 | 0.001                              | 0               | All               | Immediately  | Tuning         | page 9-81 |  |

Continued on next page.

16.1 List of Servo Parameters

16.1.2 List of Parameters

Continued from previous page.

| Parameter No.                    | Size   | Name   | Setting Range   | Setting Unit   | Default Setting | Applicable Motors | When Enabled | Classification | Reference                       |               |  |
|----------------------------------|--------|--|---|--|-----------------|-------------------|--------------|----------------|---------------------------------|---------------|--|
| Pn423<br>(A: 2423h,<br>B: 2C23h) | 2      | Speed Ripple Compensation Selections                       | 0000h to 1111h  | -  | 0000h           | Rotary            | -            | Setup          | page 9-59                       |               |  |
|                                  | n.□□□X |  | Speed Ripple Compensation Function Selection  |  |                 |                   |              |                | When Enabled                    |               |  |
|                                  |        |  | 0   | Disable speed ripple compensation.   |                 |                   |              |                |                                 | Immediately   |  |
|                                  |        |  | 1   | Enable speed ripple compensation.  |                 |                   |              |                |                                 |               |  |
|                                  | n.□□□□ |  | Speed Ripple Compensation Information Disagreement Warning Detection Selection  |  |                 |                   |              |                | When Enabled                    |               |  |
|                                  |        |  | 0   | Detect A.942 alarms.   |                 |                   |              |                |                                 | After restart |  |
|                                  |        | 1  | Do not detect A.942 alarms.   |  |                 |                   |              |                |                                 |               |  |
| n.□X□□                           |        | Speed Ripple Compensation Enable Condition Selection       |   |  |                 |                   |              | When Enabled   |                                 |               |  |
|                                  |        | 0  | Speed reference   |  |                 |                   |              |                | After restart                   |               |  |
|                                  |        | 1  | Motor speed   |  |                 |                   |              |                |                                 |               |  |
| n.X□□□                           |        | Reserved parameter (Do not change.)                        |   |  |                 |                   |              |                |                                 |               |  |
| Pn424<br>(A: 2424h,<br>B: 2C24h) | 2      | Torque Limit at Main Circuit Voltage Drop                  | 0 to 100  | 1%*1   | 50              | All               | Immediately  | Setup          | page 7-19                       |               |  |
| Pn425<br>(A: 2425h,<br>B: 2C25h) | 2      | Release Time for Torque Limit at Main Circuit Voltage Drop | 0 to 1,000  | 1 ms   | 100             | All               | Immediately  | Setup          | page 7-19                       |               |  |
| Pn426<br>(A: 2426h,<br>B: 2C26h) | 2      | Torque Feedforward Average Movement Time                   | 0 to 5,100  | 0.1 ms   | 0               | All               | Immediately  | Setup          | page 9-87                       |               |  |
| Pn427<br>(A: 2427h,<br>B: 2C27h) | 2      | Speed Ripple Compensation Enable Speed                     | 0 to 10,000   | 1 min <sup>-1</sup>  | 0               | Rotary            | Immediately  | Tuning         | page 9-59                       |               |  |
| Pn456<br>(A: 2456h,<br>B: 2C56h) | 2      | Sweep Torque Reference Amplitude                           | 1 to 800  | 1%   | 15              | All               | Immediately  | Tuning         | page 9-93                       |               |  |
| Pn460<br>(A: 2460h,<br>B: 2C60h) | 2      | Notch Filter Adjustment Selections 1                       | 0000h to 0101h  | -  | 0101h           | All               | Immediately  | Tuning         | page 9-12, page 9-24, page 9-42 |               |  |
|                                  | n.□□□X |  | Notch Filter Adjustment Selection 1   |  |                 |                   |              |                |                                 |               |  |
|                                  |        |  | 0   | Do not adjust the first stage notch filter automatically during execution of autotuning without a host reference, autotuning with a host reference, and custom tuning. |                 |                   |              |                |                                 |               |  |
|                                  |        |  | 1   | Adjust the first stage notch filter automatically during execution of autotuning without a host reference, autotuning with a host reference, and custom tuning.        |                 |                   |              |                |                                 |               |  |
|                                  | n.□□X□ |  | Reserved parameter (Do not change.)   |  |                 |                   |              |                |                                 |               |  |
|                                  | n.□X□□ |  | Notch Filter Adjustment Selection 2   |  |                 |                   |              |                |                                 |               |  |
|                                  |        | 0  | Do not adjust the second stage notch filter automatically when the tuning-less function is enabled or during execution of autotuning without a host reference, autotuning with a host reference, and custom tuning. |  |                 |                   |              |                |                                 |               |  |
|                                  |        | 1  | Adjust the second stage notch filter automatically when the tuning-less function is enabled or during execution of autotuning without a host reference, autotuning with a host reference, and custom tuning.        |  |                 |                   |              |                |                                 |               |  |
| n.X□□□                           |        | Reserved parameter (Do not change.)                        |   |  |                 |                   |              |                |                                 |               |  |

Continued on next page.

Continued from previous page.

| Parameter No.                    | Size   | Name  | Setting Range                       | Setting Unit                  | Default Setting | Applicable Motors | When Enabled  | Classification | Reference |  |
|----------------------------------|--------|---|-------------------------------------|-------------------------------|-----------------|-------------------|---------------|----------------|-----------|--|
| Pn475<br>(A: 2475h,<br>B: 2C75h) | 2      | Gravity Compensation-Related Selections                     | 0000h to 0001h                      | -                             | 0000h           | All               | After restart | Setup          | page 9-69 |  |
|                                  | n.□□□X |   | Gravity Compensation Selection      |                               |                 |                   |               |                |           |  |
|                                  |        |   | 0                                   | Disable gravity compensation. |                 |                   |               |                |           |  |
|                                  |        |   | 1                                   | Enable gravity compensation.  |                 |                   |               |                |           |  |
|                                  | n.□□X□ |   | Reserved parameter (Do not change.) |                               |                 |                   |               |                |           |  |
|                                  | n.□X□□ |   | Reserved parameter (Do not change.) |                               |                 |                   |               |                |           |  |
| n.X□□□                           |        | Reserved parameter (Do not change.)                         |                                     |                               |                 |                   |               |                |           |  |
| Pn476<br>(A: 2476h,<br>B: 2C76h) | 2      | Gravity Compensation Torque                                 | -1,000 to 1,000                     | 0.1%                          | 0               | All               | Immediately   | Tuning         | page 9-69 |  |
| Pn480<br>(A: 2480h,<br>B: 2C80h) | 2      | Speed Limit during Force Control                            | 0 to 10,000                         | 1 mm/s                        | 10000           | Linear            | Immediately   | Setup          | page 7-17 |  |
| Pn481<br>(A: 2481h,<br>B: 2C81h) | 2      | Polarity Detection Speed Loop Gain                          | 10 to 20,000                        | 0.1 Hz                        | 400             | Linear            | Immediately   | Tuning         | -         |  |
| Pn482<br>(A: 2482h,<br>B: 2C82h) | 2      | Polarity Detection Speed Loop Integral Time Constant        | 15 to 51,200                        | 0.01 ms                       | 3000            | Linear            | Immediately   | Tuning         | -         |  |
| Pn483<br>(A: 2483h,<br>B: 2C83h) | 2      | Forward Force Limit   | 0 to 800                            | 1%*1                          | 30              | Linear            | Immediately   | Setup          | page 7-23 |  |
| Pn484<br>(A: 2484h,<br>B: 2C84h) | 2      | Reverse Force Limit   | 0 to 800                            | 1%*1                          | 30              | Linear            | Immediately   | Setup          | page 7-23 |  |
| Pn485<br>(A: 2485h,<br>B: 2C85h) | 2      | Polarity Detection Reference Speed                          | 0 to 100                            | 1 mm/s                        | 20              | Linear            | Immediately   | Tuning         | -         |  |
| Pn486<br>(A: 2486h,<br>B: 2C86h) | 2      | Polarity Detection Reference Acceleration/Deceleration Time | 0 to 100                            | 1 ms                          | 25              | Linear            | Immediately   | Tuning         | -         |  |
| Pn487<br>(A: 2487h,<br>B: 2C87h) | 2      | Polarity Detection Constant Speed Time                      | 0 to 300                            | 1 ms                          | 0               | Linear            | Immediately   | Tuning         | -         |  |
| Pn488<br>(A: 2488h,<br>B: 2C88h) | 2      | Polarity Detection Reference Waiting Time                   | 50 to 500                           | 1 ms                          | 100             | Linear            | Immediately   | Tuning         | -         |  |
| Pn48E<br>(A: 248Eh,<br>B: 2C8Eh) | 2      | Polarity Detection Range                                    | 1 to 65,535                         | 1 mm                          | 10              | Linear            | Immediately   | Tuning         | -         |  |
| Pn490<br>(A: 2490h,<br>B: 2C90h) | 2      | Polarity Detection Load Level                               | 0 to 20,000                         | 1%                            | 100             | Linear            | Immediately   | Tuning         | -         |  |
| Pn495<br>(A: 2495h,<br>B: 2C95h) | 2      | Polarity Detection Confirmation Force Reference             | 0 to 200                            | 1%                            | 100             | Linear            | Immediately   | Tuning         | -         |  |
| Pn498<br>(A: 2498h,<br>B: 2C98h) | 2      | Polarity Detection Allowable Error Range                    | 0 to 30                             | 1 deg                         | 10              | Linear            | Immediately   | Tuning         | -         |  |
| Pn49F<br>(A: 249Fh,<br>B: 2C9Fh) | 2      | Speed Ripple Compensation Enable Speed                      | 0 to 10,000                         | 1 mm/s                        | 0               | Linear            | Immediately   | Tuning         | page 9-59 |  |
| Pn502<br>(A: 2502h,<br>B: 2D02h) | 2      | Rotation Detection Level                                    | 1 to 10,000                         | 1 min <sup>-1</sup>           | 20              | Rotary            | Immediately   | Setup          | page 7-10 |  |

Continued on next page.

16.1 List of Servo Parameters

16.1.2 List of Parameters

Continued from previous page.

| Parameter No.                    | Size   | Name   | Setting Range  | Setting Unit        | Default Setting | Applicable Motors | When Enabled  | Classification | Reference |
|----------------------------------|--------|--|--|---------------------|-----------------|-------------------|---------------|----------------|-----------|
| Pn503<br>(A: 2503h,<br>B: 2D03h) | 2      | Speed Coincidence Detection Signal Output Width  | 0 to 100   | 1 min <sup>-1</sup> | 10              | Rotary            | Immediately   | Setup          | page 7-12 |
| Pn506<br>(A: 2506h,<br>B: 2D06h) | 2      | Brake Reference-Servo OFF Delay Time   | 0 to 50  | 10 ms               | 0*5             | All               | Immediately   | Setup          | page 6-31 |
| Pn507<br>(A: 2507h,<br>B: 2D07h) | 2      | Brake Reference Output Speed Level   | 0 to 10,000  | 1 min <sup>-1</sup> | 100             | Rotary            | Immediately   | Setup          | page 6-31 |
| Pn508<br>(A: 2508h,<br>B: 2D08h) | 2      | Servo OFF-Brake Command Waiting Time   | 10 to 100  | 10 ms               | 50              | All               | Immediately   | Setup          | page 6-31 |
| Pn509<br>(2509h)<br>Common       | 2      | Momentary Power Interruption Hold Time   | 20 to 50,000   | 1 ms                | 20              | All               | Immediately   | Setup          | page 7-18 |
| Pn50A<br>(A: 250Ah,<br>B: 2D0Ah) | 2      | Input Signal Selections 1  | 0000h to FFF2h   | -                   | 1881h           | All               | After restart | Setup          | -         |
|                                  | n.□□□X | I/O Signal Allocation Mode   |  |                     |                 |                   |               |                | Reference |
|                                  |        | 0  | Reserved parameter (Do not change.)  |                     |                 |                   |               |                | page 7-3  |
|                                  |        | 1  | Use Σ-7S-compatible I/O signal allocations (Pn50A to Pn517).   |                     |                 |                   |               |                |           |
|                                  |        | 2  | Use multi-axis I/O signal allocations (Pn590 to Pn5BC).  |                     |                 |                   |               |                |           |
|                                  | n.□□X□ | Reserved parameter (Do not change.)  |  |                     |                 |                   |               |                |           |
|                                  | n.□X□□ | Reserved parameter (Do not change.)  |  |                     |                 |                   |               |                |           |
|                                  | n.X□□□ | P-OT (Forward Drive Prohibit) Signal Allocation  |  |                     |                 |                   |               |                | Reference |
|                                  |        | 0  | Reserved parameter (Do not change.)  |                     |                 |                   |               |                | page 6-25 |
|                                  |        | 1  | Axis A: Enable forward drive when CN1-7 input signal is ON (closed).<br>Axis B: Enable forward drive when CN1-12 input signal is ON (closed).  |                     |                 |                   |               |                |           |
|                                  |        | 2  | Axis A: Enable forward drive when CN1-8 input signal is ON (closed).<br>Axis B: Enable forward drive when CN1-13 input signal is ON (closed).  |                     |                 |                   |               |                |           |
|                                  |        | 3  | Axis A: Enable forward drive when CN1-9 input signal is ON (closed).<br>Axis B: Enable forward drive when CN1-18 input signal is ON (closed).  |                     |                 |                   |               |                |           |
|                                  |        | 4  | Axis A: Enable forward drive when CN1-10 input signal is ON (closed).<br>Axis B: Enable forward drive when CN1-19 input signal is ON (closed). |                     |                 |                   |               |                |           |
|                                  |        | 5  | Axis A: Enable forward drive when CN1-11 input signal is ON (closed).<br>Axis B: Enable forward drive when CN1-20 input signal is ON (closed). |                     |                 |                   |               |                |           |
|                                  |        | 6  | Reserved parameter (Do not change.)  |                     |                 |                   |               |                |           |
|                                  | 7      | Set the signal to always prohibit forward drive.   |  |                     |                 |                   |               |                |           |
|                                  | 8      | Set the signal to always enable forward drive.   |  |                     |                 |                   |               |                |           |
|                                  | 9      | Reserved parameter (Do not change.)  |  |                     |                 |                   |               |                |           |
|                                  | A      | Axis A: Enable forward drive when CN1-7 input signal is OFF (open).<br>Axis B: Enable forward drive when CN1-12 input signal is OFF (open).  |  |                     |                 |                   |               |                |           |
|                                  | B      | Axis A: Enable forward drive when CN1-8 input signal is OFF (open).<br>Axis B: Enable forward drive when CN1-13 input signal is OFF (open).  |  |                     |                 |                   |               |                |           |
|                                  | C      | Axis A: Enable forward drive when CN1-9 input signal is OFF (open).<br>Axis B: Enable forward drive when CN1-18 input signal is OFF (open).  |  |                     |                 |                   |               |                |           |
|                                  | D      | Axis A: Enable forward drive when CN1-10 input signal is OFF (open).<br>Axis B: Enable forward drive when CN1-19 input signal is OFF (open). |  |                     |                 |                   |               |                |           |
|                                  | E      | Axis A: Enable forward drive when CN1-11 input signal is OFF (open).<br>Axis B: Enable forward drive when CN1-20 input signal is OFF (open). |  |                     |                 |                   |               |                |           |
|                                  | F      | Reserved parameter (Do not change.)  |  |                     |                 |                   |               |                |           |

Continued on next page.

Continued from previous page.

| Parameter No.                    | Size   | Name   | Setting Range  | Setting Unit | Default Setting | Applicable Motors | When Enabled  | Classification | Reference |
|----------------------------------|--------|--|----------------|--------------|-----------------|-------------------|---------------|----------------|-----------|
| Pn50B<br>(A: 250Bh,<br>B: 2D0Bh) | 2      | Input Signal Selections 2  | 0000h to FFFFh | -            | 8882h           | All               | After restart | Setup          | -         |
|                                  | n.□□□X | N-OT (Reverse Drive Prohibit) Signal Allocation  |                |              |                 |                   |               |                | Reference |
|                                  | 0      | Reserved parameter (Do not change.)  |                |              |                 |                   |               |                | page 6-25 |
|                                  | 1      | Axis A: Enable reverse drive when CN1-7 input signal is ON (closed).<br>Axis B: Enable reverse drive when CN1-12 input signal is ON (closed).  |                |              |                 |                   |               |                |           |
|                                  | 2      | Axis A: Enable reverse drive when CN1-8 input signal is ON (closed).<br>Axis B: Enable reverse drive when CN1-13 input signal is ON (closed).  |                |              |                 |                   |               |                |           |
|                                  | 3      | Axis A: Enable reverse drive when CN1-9 input signal is ON (closed).<br>Axis B: Enable reverse drive when CN1-18 input signal is ON (closed).  |                |              |                 |                   |               |                |           |
|                                  | 4      | Axis A: Enable reverse drive when CN1-10 input signal is ON (closed).<br>Axis B: Enable reverse drive when CN1-19 input signal is ON (closed). |                |              |                 |                   |               |                |           |
|                                  | 5      | Axis A: Enable reverse drive when CN1-11 input signal is ON (closed).<br>Axis B: Enable reverse drive when CN1-20 input signal is ON (closed). |                |              |                 |                   |               |                |           |
|                                  | 6      | Reserved parameter (Do not change.)  |                |              |                 |                   |               |                |           |
|                                  | 7      | Set the signal to always prohibit reverse drive.   |                |              |                 |                   |               |                |           |
|                                  | 8      | Set the signal to always enable reverse drive.   |                |              |                 |                   |               |                |           |
|                                  | 9      | Reserved parameter (Do not change.)  |                |              |                 |                   |               |                |           |
|                                  | A      | Axis A: Enable reverse drive when CN1-7 input signal is OFF (open).<br>Axis B: Enable reverse drive when CN1-12 input signal is OFF (open).    |                |              |                 |                   |               |                |           |
|                                  | B      | Axis A: Enable reverse drive when CN1-8 input signal is OFF (open).<br>Axis B: Enable reverse drive when CN1-13 input signal is OFF (open).    |                |              |                 |                   |               |                |           |
|                                  | C      | Axis A: Enable reverse drive when CN1-9 input signal is OFF (open).<br>Axis B: Enable reverse drive when CN1-18 input signal is OFF (open).    |                |              |                 |                   |               |                |           |
|                                  | D      | Axis A: Enable reverse drive when CN1-10 input signal is OFF (open).<br>Axis B: Enable reverse drive when CN1-19 input signal is OFF (open).   |                |              |                 |                   |               |                |           |
|                                  | E      | Axis A: Enable reverse drive when CN1-11 input signal is OFF (open).<br>Axis B: Enable reverse drive when CN1-20 input signal is OFF (open).   |                |              |                 |                   |               |                |           |
|                                  | F      | Reserved parameter (Do not change.)  |                |              |                 |                   |               |                |           |
|                                  | n.□□X□ | Reserved parameter (Do not change.)  |                |              |                 |                   |               |                |           |

Continued on next page.

16.1 List of Servo Parameters

16.1.2 List of Parameters

Continued from previous page.

| Parameter No.                    | Size   | Name   | Setting Range  | Setting Unit | Default Setting | Applicable Motors | When Enabled     | Classification | Reference |           |
|----------------------------------|--|--|--|--------------|-----------------|-------------------|------------------|----------------|-----------|-----------|
| Pn50B<br>(A: 250Bh,<br>B: 2D0Bh) | n.X□□□   | <b>/P-CL (Forward External Torque Limit Input) Signal Allocation</b>                   |  |              |                 |                   |                  |                | Reference |           |
|                                  |  | 0  | Reserved parameter (Do not change.)  |              |                 |                   |                  |                |           | page 7-23 |
|                                  |  | 1  | Axis A: Active when CN1-7 input signal is ON (closed).<br>Axis B: Active when CN1-12 input signal is ON (closed).                                |              |                 |                   |                  |                |           |           |
|                                  |  | 2  | Axis A: Active when CN1-8 input signal is ON (closed).<br>Axis B: Active when CN1-13 input signal is ON (closed).                                |              |                 |                   |                  |                |           |           |
|                                  |  | 3  | Axis A: Active when CN1-9 input signal is ON (closed).<br>Axis B: Active when CN1-18 input signal is ON (closed).                                |              |                 |                   |                  |                |           |           |
|                                  |  | 4  | Axis A: Active when CN1-10 input signal is ON (closed).<br>Axis B: Active when CN1-19 input signal is ON (closed).                               |              |                 |                   |                  |                |           |           |
|                                  |  | 5  | Axis A: Active when CN1-11 input signal is ON (closed).<br>Axis B: Active when CN1-20 input signal is ON (closed).                               |              |                 |                   |                  |                |           |           |
|                                  |  | 6  | Reserved parameter (Do not change.)  |              |                 |                   |                  |                |           |           |
|                                  |  | 7  | The signal is always active.   |              |                 |                   |                  |                |           |           |
|                                  |  | 8  | The signal is always inactive.   |              |                 |                   |                  |                |           |           |
|                                  |  | 9  | Reserved parameter (Do not change.)  |              |                 |                   |                  |                |           |           |
|                                  |  | A  | Axis A: Active when CN1-7 input signal is OFF (open).<br>Axis B: Active when CN1-12 input signal is OFF (open).                                  |              |                 |                   |                  |                |           |           |
|                                  |  | B  | Axis A: Active when CN1-8 input signal is OFF (open).<br>Axis B: Active when CN1-13 input signal is OFF (open).                                  |              |                 |                   |                  |                |           |           |
|                                  |  | C  | Axis A: Active when CN1-9 input signal is OFF (open).<br>Axis B: Active when CN1-18 input signal is OFF (open).                                  |              |                 |                   |                  |                |           |           |
|                                  |  | D  | Axis A: Active when CN1-10 input signal is OFF (open).<br>Axis B: Active when CN1-19 input signal is OFF (open).                                 |              |                 |                   |                  |                |           |           |
| E                                | Axis A: Active when CN1-11 input signal is OFF (open).<br>Axis B: Active when CN1-20 input signal is OFF (open). |  |  |              |                 |                   |                  |                |           |           |
| F                                | Reserved parameter (Do not change.)  |  |  |              |                 |                   |                  |                |           |           |
| n.X□□□                           |  | <b>/N-CL (Reverse External Torque Limit Input) Signal Allocation</b>                   |  |              |                 |                   |                  |                | Reference |           |
|                                  |  | 0 to F   | The allocations are the same as the /P-CL (Forward External Torque Limit Input) signal allocations.  |              |                 |                   |                  |                |           | page 7-24 |
| 2                                | Output Signal Selections<br>1  |  | 0000h to<br>6666h  | -            | 0000h           | All               | After<br>restart | Setup          | -         |           |
| Pn50E<br>(A: 250Eh,<br>B: 2D0Eh) | n.□□□X   | <b>/COIN (Positioning Completion Output) Signal Allocation</b>                         |  |              |                 |                   |                  |                | Reference |           |
|                                  |  | 0  | Disabled (the above signal output is not used).  |              |                 |                   |                  |                |           | page 7-14 |
|                                  |  | 1  | Axis A: Output the signal from the CN1-1 and CN1-2 output terminals.<br>Axis B: Output the signal from the CN1-23 and CN1-24 output terminals.   |              |                 |                   |                  |                |           |           |
|                                  |  | 2  | Axis A: Output the signal from the CN1-25 and CN1-26 output terminals.<br>Axis B: Output the signal from the CN1-27 and CN1-28 output terminals. |              |                 |                   |                  |                |           |           |
|                                  |  | 3 to 6   | Reserved parameters (Do not change.)   |              |                 |                   |                  |                |           |           |
|                                  | n.□□□X   | <b>/V-CMP (Speed Coincidence Detection Output) Signal Allocation</b>                   |  |              |                 |                   |                  |                | Reference |           |
|                                  | 0 to 6   | The allocations are the same as the /COIN (Positioning Completion) signal allocations. |  |              |                 |                   |                  |                | page 7-12 |           |
|                                  | n.□X□□   | <b>/TGON (Rotation Detection Output) Signal Allocation</b>                             |  |              |                 |                   |                  |                | Reference |           |
|                                  | 0 to 6   | The allocations are the same as the /COIN (Positioning Completion) signal allocations. |  |              |                 |                   |                  |                | page 7-10 |           |
|                                  | n.X□□□   | <b>/S-RDY (Servo Ready) Signal Allocation</b>  |  |              |                 |                   |                  |                | Reference |           |
|                                  | 0 to 6   | The allocations are the same as the /COIN (Positioning Completion) signal allocations. |  |              |                 |                   |                  |                | page 7-12 |           |

Continued on next page.

Continued from previous page.

| Parameter No.                    | Size                                | Name   | Setting Range  | Setting Unit      | Default Setting | Applicable Motors | When Enabled     | Classification   | Reference |           |
|----------------------------------|-------------------------------------|--|--|-------------------|-----------------|-------------------|------------------|------------------|-----------|-----------|
| Pn50F<br>(A: 250Fh,<br>B: 2D0Fh) | 2                                   | Output Signal Selections<br>2                          | 0000h to<br>6666h  | –                 | 0100h           | All               | After<br>restart | Setup            | –         |           |
|                                  | n.□□□X                              | /CLT (Torque Limit Detection Output) Signal Allocation |  |                   |                 |                   |                  |                  | Reference |           |
|                                  |                                     | 0  | Disabled (the above signal output is not used).  |                   |                 |                   |                  |                  |           | page 7-27 |
|                                  |                                     | 1  | Axis A: Output the signal from the CN1-1 and CN1-2 output terminals.<br>Axis B: Output the signal from the CN1-23 and CN1-24 output terminals.   |                   |                 |                   |                  |                  |           |           |
|                                  |                                     | 2  | Axis A: Output the signal from the CN1-25 and CN1-26 output terminals.<br>Axis B: Output the signal from the CN1-27 and CN1-28 output terminals. |                   |                 |                   |                  |                  |           |           |
|                                  |                                     | 3 to 6   | Reserved parameters (Do not change.)   |                   |                 |                   |                  |                  |           |           |
|                                  | n.□□X□                              | /VLT (Speed Limit Detection) Signal Allocation         |  |                   |                 |                   |                  |                  | Reference |           |
|                                  |                                     | 0 to 6   | The allocations are the same as the /CLT (Torque Limit Detection Output) signal allocations.   |                   |                 |                   |                  |                  |           | page 7-16 |
|                                  | n.□X□□                              | /BK (Brake Output) Signal Allocation                   |  |                   |                 |                   |                  |                  | Reference |           |
|                                  |                                     | 0  | Disabled (the above signal output is not used).  |                   |                 |                   |                  |                  |           | page 7-27 |
|                                  |                                     | 1  | Axis A: Output the signal from the CN1-1 and CN1-2 output terminals.<br>Axis B: Output the signal from the CN1-23 and CN1-24 output terminals.   |                   |                 |                   |                  |                  |           |           |
|                                  |                                     | 2  | Axis A: Output the signal from the CN1-25 and CN1-26 output terminals.<br>Axis B: Output the signal from the CN1-27 and CN1-28 output terminals. |                   |                 |                   |                  |                  |           |           |
|                                  |                                     | 3 to 6   | Reserved parameters (Do not change.)   |                   |                 |                   |                  |                  |           |           |
|                                  | n.X□□□                              | /WARN (Warning Output) Signal Allocation               |  |                   |                 |                   |                  |                  | Reference |           |
|                                  |                                     | 0 to 6   | The allocations are the same as the /CLT (Torque Limit Detection Output) signal allocations.   |                   |                 |                   |                  |                  |           | page 7-10 |
|                                  | Pn510<br>(A: 2510h,<br>B: 2D10h)    | 2  | Output Signal Selections<br>3  | 0000h to<br>0666h | –               | 0000h             | All              | After<br>restart | Setup     | –         |
|                                  |                                     | n.□□□X   | /NEAR (Near Output) Signal Allocation  |                   |                 |                   |                  |                  |           | Reference |
|                                  |                                     | 0  | Disabled (the above signal output is not used).  |                   |                 |                   |                  |                  |           | page 7-15 |
|                                  |                                     | 1  | Axis A: Output the signal from the CN1-1 and CN1-2 output terminals.<br>Axis B: Output the signal from the CN1-23 and CN1-24 output terminals.   |                   |                 |                   |                  |                  |           |           |
|                                  |                                     | 2  | Axis A: Output the signal from the CN1-25 and CN1-26 output terminals.<br>Axis B: Output the signal from the CN1-27 and CN1-28 output terminals. |                   |                 |                   |                  |                  |           |           |
|                                  |                                     | 3 to 6   | Reserved parameters (Do not change.)   |                   |                 |                   |                  |                  |           |           |
| n.□□X□                           |                                     | Reserved parameter (Do not change.)                    |  |                   |                 |                   |                  |                  |           |           |
| n.□X□□                           |                                     | Reserved parameter (Do not change.)                    |  |                   |                 |                   |                  |                  |           |           |
| n.X□□□                           | Reserved parameter (Do not change.) |  |  |                   |                 |                   |                  |                  |           |           |

Continued on next page.

16.1 List of Servo Parameters

16.1.2 List of Parameters

Continued from previous page.

| Parameter No.                    | Size                             | Name   | Setting Range  | Setting Unit   | Default Setting | Applicable Motors | When Enabled  | Classification | Reference |          |
|----------------------------------|----------------------------------|--|--|----------------|-----------------|-------------------|---------------|----------------|-----------|----------|
| Pn511<br>(A: 2511h,<br>B: 2D11h) | 2                                | Input Signal Selections 5  | 0000h to FFFFh   | -              | 5432h           | All               | After restart | Setup          | page 7-3  |          |
|                                  | n.□□□X                           | Reserved parameter (Do not change.)  |  |                |                 |                   |               |                |           |          |
|                                  | n.□□□□                           | /Probe1 (Probe 1 Latch Input) Signal Allocation  |  |                |                 |                   |               |                |           |          |
|                                  |                                  | 0 to 2   | The signal is always inactive.   |                |                 |                   |               |                |           |          |
|                                  |                                  | 3  | Axis A: Active when CN1-9 input signal is ON (closed).<br>Axis B: Active when CN1-18 input signal is ON (closed).    |                |                 |                   |               |                |           |          |
|                                  |                                  | 4  | Axis A: Active when CN1-10 input signal is ON (closed).<br>Axis B: Active when CN1-19 input signal is ON (closed).   |                |                 |                   |               |                |           |          |
|                                  |                                  | 5  | Axis A: Active when CN1-11 input signal is ON (closed).<br>Axis B: Active when CN1-20 input signal is ON (closed).   |                |                 |                   |               |                |           |          |
|                                  |                                  | 6 to B   | The signal is always inactive.   |                |                 |                   |               |                |           |          |
|                                  |                                  | C  | Axis A: Active when CN1-9 input signal is OFF (open).<br>Axis B: Active when CN1-18 input signal is OFF (open).      |                |                 |                   |               |                |           |          |
|                                  |                                  | D  | Axis A: Active when CN1-10 input signal is OFF (open).<br>Axis B: Active when CN1-19 input signal is OFF (open).     |                |                 |                   |               |                |           |          |
|                                  |                                  | E  | Axis A: Active when CN1-11 input signal is OFF (open).<br>Axis B: Active when CN1-20 input signal is OFF (open).     |                |                 |                   |               |                |           |          |
|                                  |                                  | F  | The signal is always enabled.  |                |                 |                   |               |                |           |          |
|                                  | n.□X□□                           | /Probe2 (Probe 2 Latch Input) Signal Allocation  |  |                |                 |                   |               |                |           |          |
|                                  |                                  | 0 to F   | The allocations are the same as the /Probe1 (Probe 1 Latch Input) signal allocations.                                |                |                 |                   |               |                |           |          |
|                                  | n.X□□□                           | /Home (Home Switch Input) Signal Allocation  |  |                |                 |                   |               |                |           |          |
|                                  |                                  | 0 to F   | The allocations are the same as the /Probe1 (Probe 1 Latch Input) signal allocations.                                |                |                 |                   |               |                |           |          |
|                                  | Pn512<br>(A: 2512h,<br>B: 2D12h) | 2  | Output Signal Inverse Settings   | 0000h to 1111h | -               | 0000h             | All           | After restart  | Setup     | page 7-7 |
|                                  |                                  | n.□□□X   | Output Inversion for CN1-1, CN1-2, CN1-23, and CN1-24 Terminals (Axis A: CN1-1 and CN1-2, Axis B: CN1-23 and CN1-24) |                |                 |                   |               |                |           |          |
|                                  |                                  | 0  | The signal is not inverted.  |                |                 |                   |               |                |           |          |
|                                  |                                  | 1  | The signal is inverted.  |                |                 |                   |               |                |           |          |
| n.□□X□                           |                                  | Output Inversion for CN1-25, CN1-26, CN1-27, and CN1-28 Terminals (Axis A: CN1-25 and CN1-26, Axis B: CN1-27 and CN1-28) |  |                |                 |                   |               |                |           |          |
|                                  |                                  | 0  | The signal is not inverted.  |                |                 |                   |               |                |           |          |
|                                  |                                  | 1  | The signal is inverted.  |                |                 |                   |               |                |           |          |
| n.□X□□                           |                                  | Reserved parameter (Do not change.)  |  |                |                 |                   |               |                |           |          |
| n.X□□□                           |                                  | Reserved parameter (Do not change.)  |  |                |                 |                   |               |                |           |          |

Continued on next page.



Continued from previous page.

| Parameter No.                    | Size                             | Name                                | Setting Range  | Setting Unit   | Default Setting | Applicable Motors | When Enabled  | Classification | Reference |           |
|----------------------------------|----------------------------------|-------------------------------------|--|----------------|-----------------|-------------------|---------------|----------------|-----------|-----------|
| Pn514<br>(A: 2514h,<br>B: 2D14h) | 2                                | Output Signal Selections 4          | 0000h to 0666h   | –              | 0000h           | All               | After restart | Setup          | –         |           |
|                                  |                                  | n.□□□X                              | Reserved parameter (Do not change.)  |                |                 |                   |               |                |           |           |
|                                  |                                  | n.□□X□                              | Reserved parameter (Do not change.)  |                |                 |                   |               |                |           |           |
|                                  |                                  | n.□X□□                              | /PM (Preventative Maintenance Output) Signal Allocation  |                |                 |                   |               |                |           | Reference |
|                                  |                                  | 0                                   | Disabled (the above signal output is not used).  |                |                 |                   |               |                |           | page 7-15 |
|                                  |                                  | 1                                   | Axis A: Output the signal from the CN1-1 and CN1-2 output terminals.<br>Axis B: Output the signal from the CN1-23 and CN1-24 output terminals.   |                |                 |                   |               |                |           |           |
|                                  |                                  | 2                                   | Axis A: Output the signal from the CN1-25 and CN1-26 output terminals.<br>Axis B: Output the signal from the CN1-27 and CN1-28 output terminals. |                |                 |                   |               |                |           |           |
|                                  |                                  | 3 to 6                              | Reserved parameters (Do not change.)   |                |                 |                   |               |                |           |           |
|                                  |                                  | n.X□□□                              | Reserved parameter (Do not change.)  |                |                 |                   |               |                |           |           |
|                                  | Pn516<br>(A: 2516h,<br>B: 2D16h) | 2                                   | Input Signal Selections 7  | 0000h to FFFFh | –               | 8888h             | All           | After restart  | Setup     | –         |
|                                  |                                  | n.□□□X                              | FSTP (Forced Stop Input) Signal Allocation   |                |                 |                   |               |                |           | Reference |
|                                  |                                  | 0                                   | Reserved parameter (Do not change.)  |                |                 |                   |               |                |           | page 7-24 |
|                                  |                                  | 1                                   | Axis A: Active when CN1-7 input signal is ON (closed).<br>Axis B: Active when CN1-12 input signal is ON (closed).                                |                |                 |                   |               |                |           |           |
|                                  |                                  | 2                                   | Axis A: Active when CN1-8 input signal is ON (closed).<br>Axis B: Active when CN1-13 input signal is ON (closed).                                |                |                 |                   |               |                |           |           |
|                                  |                                  | 3                                   | Axis A: Active when CN1-9 input signal is ON (closed).<br>Axis B: Active when CN1-18 input signal is ON (closed).                                |                |                 |                   |               |                |           |           |
|                                  |                                  | 4                                   | Axis A: Active when CN1-10 input signal is ON (closed).<br>Axis B: Active when CN1-19 input signal is ON (closed).                               |                |                 |                   |               |                |           |           |
|                                  |                                  | 5                                   | Axis A: Active when CN1-11 input signal is ON (closed).<br>Axis B: Active when CN1-20 input signal is ON (closed).                               |                |                 |                   |               |                |           |           |
|                                  |                                  | 6                                   | Reserved parameter (Do not change.)  |                |                 |                   |               |                |           |           |
|                                  |                                  | 7                                   | The signal is always active.   |                |                 |                   |               |                |           |           |
|                                  |                                  | 8                                   | The signal is always inactive.   |                |                 |                   |               |                |           |           |
|                                  |                                  | 9                                   | Reserved parameter (Do not change.)  |                |                 |                   |               |                |           |           |
|                                  |                                  | A                                   | Axis A: Active when CN1-7 input signal is OFF (open).<br>Axis B: Active when CN1-12 input signal is OFF (open).                                  |                |                 |                   |               |                |           |           |
|                                  |                                  | B                                   | Axis A: Active when CN1-8 input signal is OFF (open).<br>Axis B: Active when CN1-13 input signal is OFF (open).                                  |                |                 |                   |               |                |           |           |
|                                  |                                  | C                                   | Axis A: Active when CN1-9 input signal is OFF (open).<br>Axis B: Active when CN1-18 input signal is OFF (open).                                  |                |                 |                   |               |                |           |           |
|                                  |                                  | D                                   | Axis A: Active when CN1-10 input signal is OFF (open).<br>Axis B: Active when CN1-19 input signal is OFF (open).                                 |                |                 |                   |               |                |           |           |
|                                  |                                  | E                                   | Axis A: Active when CN1-11 input signal is OFF (open).<br>Axis B: Active when CN1-20 input signal is OFF (open).                                 |                |                 |                   |               |                |           |           |
|                                  |                                  | F                                   | Reserved parameter (Do not change.)  |                |                 |                   |               |                |           |           |
|                                  |                                  | n.□□X□                              | Reserved parameter (Do not change.)  |                |                 |                   |               |                |           |           |
|                                  |                                  | n.□X□□                              | Reserved parameter (Do not change.)  |                |                 |                   |               |                |           |           |
|                                  | n.X□□□                           | Reserved parameter (Do not change.) |  |                |                 |                   |               |                |           |           |

Continued on next page.

16.1 List of Servo Parameters

16.1.2 List of Parameters

Continued from previous page.

| Parameter No.                                     | Size | Name  | Setting Range  | Setting Unit        | Default Setting | Applicable Motors | When Enabled  | Classification | Reference              |  |  |
|---|------|---|--|---------------------|-----------------|-------------------|---------------|----------------|------------------------|--|--|
| Pn51E<br>(A: 251Eh,<br>B: 2D1Eh)                  | 2    | Position Deviation Overflow Warning Level             | 10 to 100  | 1%                  | 100             | All               | Immediately   | Setup          | page 15-46             |  |  |
| Pn520<br>(A: 2520h,<br>B: 2D20h)                  | 4    | Position Deviation Overflow Alarm Level               | 1 to 1,073,741,823   | 1 reference unit    | 5242880         | All               | Immediately   | Setup          | page 9-8,<br>page 15-5 |  |  |
| Pn522<br>(A: 2522h,<br>B: 2D22h)                  | 4    | Positioning Completed Width                           | 0 to 1,073,741,824   | 1 reference unit    | 7               | All               | Immediately   | Setup          | page 7-14              |  |  |
| Pn524<br>(A: 2524h,<br>B: 2D24h)                  | 4    | Near Signal Width                                     | 1 to 1,073,741,824   | 1 reference unit    | 1073741824      | All               | Immediately   | Setup          | page 7-15              |  |  |
| Pn526<br>(A: 2526h,<br>B: 2D26h)                  | 4    | Position Deviation Overflow Alarm Level at Servo ON   | 1 to 1,073,741,823   | 1 reference unit    | 5242880         | All               | Immediately   | Setup          | page 9-8               |  |  |
| Pn528<br>(A: 2528h,<br>B: 2D28h)                  | 2    | Position Deviation Overflow Warning Level at Servo ON | 10 to 100  | 1%                  | 100             | All               | Immediately   | Setup          | page 9-8               |  |  |
| Pn529<br>(A: 2529h,<br>B: 2D29h)                  | 2    | Speed Limit Level at Servo ON                         | 0 to 10,000  | 1 min <sup>-1</sup> | 10000           | Rotary            | Immediately   | Setup          | page 9-8               |  |  |
| Pn52B<br>(A: 252Bh,<br>B: 2D2Bh)                  | 2    | Overload Warning Level                                | 1 to 100   | 1%                  | 20              | All               | Immediately   | Setup          | page 6-39              |  |  |
| Pn52C<br>(A: 252Ch,<br>B: 2D2Ch)                  | 2    | Base Current Derating at Motor Overload Detection     | 10 to 100  | 1%                  | 100             | All               | After restart | Setup          | page 6-39              |  |  |
| Pn530<br>(A: 2530h,<br>B: 2D30h)                  | 2    | Program Jogging-Related Selections                    | 0000h to 0005h   | –                   | 0000h           | All               | Immediately   | Setup          | page 8-13              |  |  |
|   |      | <b>n.□□□X</b> Program Jogging Operation Pattern       |  |                     |                 |                   |               |                |                        |  |  |
|   |      | 0   | (Waiting time in Pn535 → Forward by travel distance in Pn531) × Number of movements in Pn536   |                     |                 |                   |               |                |                        |  |  |
|   |      | 1   | (Waiting time in Pn535 → Reverse by travel distance in Pn531) × Number of movements in Pn536   |                     |                 |                   |               |                |                        |  |  |
|   |      | 2   | (Waiting time in Pn535 → Forward by travel distance in Pn531) × Number of movements in Pn536<br>(Waiting time in Pn535 → Reverse by travel distance in Pn531) × Number of movements in Pn536 |                     |                 |                   |               |                |                        |  |  |
|   |      | 3   | (Waiting time in Pn535 → Reverse by travel distance in Pn531) × Number of movements in Pn536<br>(Waiting time in Pn535 → Forward by travel distance in Pn531) × Number of movements in Pn536 |                     |                 |                   |               |                |                        |  |  |
|   |      | 4   | (Waiting time in Pn535 → Forward by travel distance in Pn531 → Waiting time in Pn535 → Reverse by travel distance in Pn531) × Number of movements in Pn536                                   |                     |                 |                   |               |                |                        |  |  |
|   |      | 5   | (Waiting time in Pn535 → Reverse by travel distance in Pn531 → Waiting time in Pn535 → Forward by travel distance in Pn531) × Number of movements in Pn536                                   |                     |                 |                   |               |                |                        |  |  |
| <b>n.□□□□</b> Reserved parameter (Do not change.) |      |   |  |                     |                 |                   |               |                |                        |  |  |
| <b>n.□X□□</b> Reserved parameter (Do not change.) |      |   |  |                     |                 |                   |               |                |                        |  |  |
| <b>n.X□□□</b> Reserved parameter (Do not change.) |      |   |  |                     |                 |                   |               |                |                        |  |  |
| Pn531<br>(A: 2531h,<br>B: 2D31h)                  | 4    | Program Jogging Travel Distance                       | 1 to 1,073,741,824   | 1 reference unit    | 32768           | All               | Immediately   | Setup          | page 8-13              |  |  |
| Pn533<br>(A: 2533h,<br>B: 2D33h)                  | 2    | Program Jogging Movement Speed                        | 1 to 10,000  | 1 min <sup>-1</sup> | 500             | Rotary            | Immediately   | Setup          | page 8-13              |  |  |

Continued on next page.

Continued from previous page.

| Parameter No.                    | Size | Name  | Setting Range     | Setting Unit         | Default Setting | Applicable Motors | When Enabled | Classification | Reference               |
|----------------------------------|------|---|-------------------|----------------------|-----------------|-------------------|--------------|----------------|-------------------------|
| Pn534<br>(A: 2534h,<br>B: 2D34h) | 2    | Program Jogging Acceleration/Deceleration Time  | 2 to 10,000       | 1 ms                 | 100             | All               | Immediately  | Setup          | page 8-13               |
| Pn535<br>(A: 2535h,<br>B: 2D35h) | 2    | Program Jogging Waiting Time                    | 0 to 10,000       | 1 ms                 | 100             | All               | Immediately  | Setup          | page 8-13               |
| Pn536<br>(A: 2536h,<br>B: 2D36h) | 2    | Program Jogging Number of Movements             | 0 to 1,000        | 1 time               | 1               | All               | Immediately  | Setup          | page 8-13               |
| Pn550<br>(2550h)<br>Common       | 2    | Analog Monitor 1 Offset Voltage                 | -10,000 to 10,000 | 0.1 V                | 0               | All               | Immediately  | Setup          | page 10-7               |
| Pn551<br>(2551h)<br>Common       | 2    | Analog Monitor 2 Offset Voltage                 | -10,000 to 10,000 | 0.1 V                | 0               | All               | Immediately  | Setup          | page 10-7               |
| Pn552<br>(2552h)<br>Common       | 2    | Analog Monitor 1 Magnification                  | -10,000 to 10,000 | × 0.01               | 100             | All               | Immediately  | Setup          | page 10-7               |
| Pn553<br>(2553h)<br>Common       | 2    | Analog Monitor 2 Magnification                  | -10,000 to 10,000 | × 0.01               | 100             | All               | Immediately  | Setup          | page 10-7               |
| Pn55A<br>(255Ah)<br>Common       | 2    | Power Consumption Monitor Unit Time             | 1 to 1,440        | 1 min                | 1               | All               | Immediately  | Setup          | –                       |
| Pn560<br>(A: 2560h,<br>B: 2D60h) | 2    | Residual Vibration Detection Width              | 1 to 3,000        | 0.1%                 | 400             | All               | Immediately  | Setup          | page 9-55               |
| Pn561<br>(A: 2561h,<br>B: 2D61h) | 2    | Overshoot Detection Level                       | 0 to 100          | 1%                   | 100             | All               | Immediately  | Setup          | page 9-24,<br>page 9-35 |
| Pn581<br>(A: 2581h,<br>B: 2D81h) | 2    | Zero Speed Level                                | 1 to 10,000       | 1 mm/s               | 20              | Linear            | Immediately  | Setup          | page 7-10               |
| Pn582<br>(A: 2582h,<br>B: 2D82h) | 2    | Speed Coincidence Detection Signal Output Width | 0 to 100          | 1 mm/s               | 10              | Linear            | Immediately  | Setup          | page 7-12               |
| Pn583<br>(A: 2583h,<br>B: 2D83h) | 2    | Brake Reference Output Speed Level              | 0 to 10,000       | 1 mm/s               | 10              | Linear            | Immediately  | Setup          | page 6-31               |
| Pn584<br>(A: 2584h,<br>B: 2D84h) | 2    | Speed Limit Level at Servo ON                   | 0 to 10,000       | 1 mm/s               | 10000           | Linear            | Immediately  | Setup          | page 9-8                |
| Pn585<br>(A: 2585h,<br>B: 2D85h) | 2    | Program Jogging Movement Speed                  | 1 to 10,000       | 1 mm/s               | 50              | Linear            | Immediately  | Setup          | page 8-13               |
| Pn586<br>(A: 2586h,<br>B: 2D86h) | 2    | Motor Running Cooling Ratio                     | 0 to 100          | 1%/<br>Max.<br>speed | 0               | Linear            | Immediately  | Setup          | –                       |

Continued on next page.

16.1 List of Servo Parameters

16.1.2 List of Parameters

Continued from previous page.

| Parameter No.                    | Size   | Name   | Setting Range  | Setting Unit                                   | Default Setting                 | Applicable Motors | When Enabled  | Classification | Reference              |           |           |
|----------------------------------|--------|--|--|--|---------------------------------|-------------------|---------------|----------------|------------------------|-----------|-----------|
| Pn587<br>(A: 2587h,<br>B: 2D87h) | 2      | Polarity Detection Execution Selection for Absolute Linear Encoder | 0000h to 0001h   | -  | 0000h                           | Linear            | Immediately   | Setup          | -                      |           |           |
|                                  | n.□□□X |  | Polarity Detection Selection for Absolute Linear Encoder |  |                                 |                   |               |                |                        | Reference |           |
|                                  |        |  | 0  | Do not detect polarity.                        |                                 |                   |               |                |                        |           | page 6-22 |
|                                  |        |  | 1  | Detect polarity.                               |                                 |                   |               |                |                        |           |           |
|                                  | n.□□X□ |  | Reserved parameter (Do not change.)                      |  |                                 |                   |               |                |                        |           |           |
|                                  | n.□X□□ |  | Reserved parameter (Do not change.)                      |  |                                 |                   |               |                |                        |           |           |
| n.X□□□                           |        | Reserved parameter (Do not change.)                                |  |  |                                 |                   |               |                |                        |           |           |
| Pn590<br>(A: 2590h,<br>B: 2D90h) | 2      | P-OT (Forward Drive Prohibit) Signal Allocation                    | 0000h to 3029h   | -  | Axis A: 1007h,<br>Axis B: 1012h | All               | After restart | Setup          | page 6-25,<br>page 7-3 |           |           |
|                                  | n.□XXX |  | Allocated Pin Number                                     |  |                                 |                   |               |                |                        |           |           |
|                                  |        |  | 000 to 006   | The signal is always inactive.                 |                                 |                   |               |                |                        |           |           |
|                                  |        |  | 007  | Allocate the signal to CN1-7.                  |                                 |                   |               |                |                        |           |           |
|                                  |        |  | 008  | Allocate the signal to CN1-8.                  |                                 |                   |               |                |                        |           |           |
|                                  |        |  | 009  | Allocate the signal to CN1-9.                  |                                 |                   |               |                |                        |           |           |
|                                  |        |  | 010  | Allocate the signal to CN1-10.                 |                                 |                   |               |                |                        |           |           |
|                                  |        |  | 011  | Allocate the signal to CN1-11.                 |                                 |                   |               |                |                        |           |           |
|                                  |        |  | 012  | Allocate the signal to CN1-12.                 |                                 |                   |               |                |                        |           |           |
|                                  |        |  | 013  | Allocate the signal to CN1-13.                 |                                 |                   |               |                |                        |           |           |
|                                  |        |  | 014 to 017   | The signal is always inactive.                 |                                 |                   |               |                |                        |           |           |
|                                  |        |  | 018  | Allocate the signal to CN1-18.                 |                                 |                   |               |                |                        |           |           |
|                                  |        |  | 019  | Allocate the signal to CN1-19.                 |                                 |                   |               |                |                        |           |           |
|                                  |        |  | 020  | Allocate the signal to CN1-20.                 |                                 |                   |               |                |                        |           |           |
|                                  | n.X□□□ |  | Polarity Selection                                       |  |                                 |                   |               |                |                        |           |           |
|                                  |        |  | 0  | Set the signal to always enable forward drive. |                                 |                   |               |                |                        |           |           |
|                                  |        | 1  | Active when input signal is ON (closed).                 |  |                                 |                   |               |                |                        |           |           |
|                                  |        | 2  | Active when input signal is OFF (open).                  |  |                                 |                   |               |                |                        |           |           |
|                                  |        | 3  | Set the signal to always prohibit forward drive.         |  |                                 |                   |               |                |                        |           |           |

Continued on next page.

Continued from previous page.

| Parameter No.                    | Size                             | Name  | Setting Range                                   | Setting Unit                                     | Default Setting                 | Applicable Motors               | When Enabled  | Classification | Reference              |   |
|----------------------------------|----------------------------------|---|---|--|---------------------------------|---------------------------------|---------------|----------------|------------------------|---|
| Pn591<br>(A: 2591h,<br>B: 2D91h) | 2                                | N-OT (Reverse Drive Prohibit) Signal Allocation | 0000h to 3029h                                  | -  | Axis A: 1008h,<br>Axis B: 1013h | All                             | After restart | Setup          | page 6-25,<br>page 7-3 |   |
|                                  | n.□XXX                           |   | Allocated Pin Number                            |  |                                 |                                 |               |                |                        |   |
|                                  |                                  |   | 000 to 006                                      | The signal is always inactive.                   |                                 |                                 |               |                |                        |   |
|                                  |                                  |   | 007   | Allocate the signal to CN1-7.                    |                                 |                                 |               |                |                        |   |
|                                  |                                  |   | 008   | Allocate the signal to CN1-8.                    |                                 |                                 |               |                |                        |   |
|                                  |                                  |   | 009   | Allocate the signal to CN1-9.                    |                                 |                                 |               |                |                        |   |
|                                  |                                  |   | 010   | Allocate the signal to CN1-10.                   |                                 |                                 |               |                |                        |   |
|                                  |                                  |   | 011   | Allocate the signal to CN1-11.                   |                                 |                                 |               |                |                        |   |
|                                  |                                  |   | 012   | Allocate the signal to CN1-12.                   |                                 |                                 |               |                |                        |   |
|                                  |                                  |   | 013   | Allocate the signal to CN1-13.                   |                                 |                                 |               |                |                        |   |
|                                  |                                  |   | 014 to 017                                      | The signal is always inactive.                   |                                 |                                 |               |                |                        |   |
|                                  |                                  |   | 018   | Allocate the signal to CN1-18.                   |                                 |                                 |               |                |                        |   |
|                                  |                                  |   | 019   | Allocate the signal to CN1-19.                   |                                 |                                 |               |                |                        |   |
|                                  |                                  |   | 020   | Allocate the signal to CN1-20.                   |                                 |                                 |               |                |                        |   |
|                                  | n.X□□□                           |   | Polarity Selection                              |  |                                 |                                 |               |                |                        |   |
|                                  |                                  |   | 0   | Set the signal to always enable reverse drive.   |                                 |                                 |               |                |                        |   |
|                                  |                                  |   | 1   | Active when input signal is ON (closed).         |                                 |                                 |               |                |                        |   |
|                                  |                                  |   | 2   | Active when input signal is OFF (open).          |                                 |                                 |               |                |                        |   |
|                                  |                                  |   | 3   | Set the signal to always prohibit reverse drive. |                                 |                                 |               |                |                        |   |
|                                  | Pn593<br>(A: 2593h,<br>B: 2D93h) | 2   | /Probe1 (Probe 1 Latch Input) Signal Allocation | 0000h to 2029h                                   | -                               | Axis A: 1009h,<br>Axis B: 1018h | All           | After restart  | Setup                  | - |
|                                  |                                  | n.□XXX  |   | Allocated Pin Number                             |                                 |                                 |               |                |                        |   |
|                                  |                                  | 000 to 008                                      | The signal is always inactive.                  |  |                                 |                                 |               |                |                        |   |
|                                  |                                  | 009   | Allocate the signal to CN1-9.                   |  |                                 |                                 |               |                |                        |   |
|                                  |                                  | 010   | Allocate the signal to CN1-10.                  |  |                                 |                                 |               |                |                        |   |
|                                  |                                  | 011   | Allocate the signal to CN1-11.                  |  |                                 |                                 |               |                |                        |   |
|                                  |                                  | 012 to 017                                      | The signal is always inactive.                  |  |                                 |                                 |               |                |                        |   |
|                                  |                                  | 018   | Allocate the signal to CN1-18.                  |  |                                 |                                 |               |                |                        |   |
|                                  |                                  | 019   | Allocate the signal to CN1-19.                  |  |                                 |                                 |               |                |                        |   |
|                                  |                                  | 020   | Allocate the signal to CN1-20.                  |  |                                 |                                 |               |                |                        |   |
| n.X□□□                           |                                  | Polarity Selection                              |   |  |                                 |                                 |               |                |                        |   |
|                                  |                                  | 0   | The signal is always inactive.                  |  |                                 |                                 |               |                |                        |   |
|                                  |                                  | 1   | Active when input signal is ON (closed).        |  |                                 |                                 |               |                |                        |   |
|                                  |                                  | 2   | Active when input signal is OFF (open).         |  |                                 |                                 |               |                |                        |   |

Continued on next page.

16.1 List of Servo Parameters

16.1.2 List of Parameters

Continued from previous page.

| Parameter No.                    | Size          | Name  | Setting Range               | Setting Unit                             | Default Setting                 | Applicable Motors | When Enabled  | Classification | Reference |  |
|----------------------------------|---------------|---|-----------------------------|--|---------------------------------|-------------------|---------------|----------------|-----------|--|
| Pn594<br>(A: 2594h,<br>B: 2D94h) | 2             | /Probe2 (Probe 2 Latch Input) Signal Allocation | 0000h to 2029h              | -  | Axis A: 1010h,<br>Axis B: 1019h | All               | After restart | Setup          | -         |  |
|                                  | <b>n.□XXX</b> |   | <b>Allocated Pin Number</b> |  |                                 |                   |               |                |           |  |
|                                  |               |   | 000 to 008                  | The signal is always inactive.           |                                 |                   |               |                |           |  |
|                                  |               |   | 009                         | Allocate the signal to CN1-9.            |                                 |                   |               |                |           |  |
|                                  |               |   | 010                         | Allocate the signal to CN1-10.           |                                 |                   |               |                |           |  |
|                                  |               |   | 011                         | Allocate the signal to CN1-11.           |                                 |                   |               |                |           |  |
|                                  |               |   | 012 to 017                  | The signal is always inactive.           |                                 |                   |               |                |           |  |
|                                  |               |   | 018                         | Allocate the signal to CN1-18.           |                                 |                   |               |                |           |  |
|                                  |               |   | 019                         | Allocate the signal to CN1-19.           |                                 |                   |               |                |           |  |
|                                  |               |   | 020                         | Allocate the signal to CN1-20.           |                                 |                   |               |                |           |  |
|                                  | <b>n.X□□□</b> |   | <b>Polarity Selection</b>   |  |                                 |                   |               |                |           |  |
|                                  |               |   | 0                           | The signal is always inactive.           |                                 |                   |               |                |           |  |
|                                  |               |   | 1                           | Active when input signal is ON (closed). |                                 |                   |               |                |           |  |
|                                  |               |   | 2                           | Active when input signal is OFF (open).  |                                 |                   |               |                |           |  |
| Pn595<br>(A: 2595h,<br>B: 2D95h) | 2             | /Home (Home Switch Input) Signal Allocation     | 0000h to 2029h              | -  | Axis A: 1011h,<br>Axis B: 1020h | All               | After restart | Setup          | -         |  |
|                                  | <b>n.□XXX</b> |   | <b>Allocated Pin Number</b> |  |                                 |                   |               |                |           |  |
|                                  |               |   | 000 to 008                  | The signal is always inactive.           |                                 |                   |               |                |           |  |
|                                  |               |   | 009                         | Allocate the signal to CN1-9.            |                                 |                   |               |                |           |  |
|                                  |               |   | 010                         | Allocate the signal to CN1-10.           |                                 |                   |               |                |           |  |
|                                  |               |   | 011                         | Allocate the signal to CN1-11.           |                                 |                   |               |                |           |  |
|                                  |               |   | 012 to 017                  | The signal is always inactive.           |                                 |                   |               |                |           |  |
|                                  |               |   | 018                         | Allocate the signal to CN1-18.           |                                 |                   |               |                |           |  |
|                                  |               |   | 019                         | Allocate the signal to CN1-19.           |                                 |                   |               |                |           |  |
|                                  |               |   | 020                         | Allocate the signal to CN1-20.           |                                 |                   |               |                |           |  |
|                                  | <b>n.X□□□</b> |   | <b>Polarity Selection</b>   |  |                                 |                   |               |                |           |  |
|                                  |               |   | 0                           | The signal is always inactive.           |                                 |                   |               |                |           |  |
|                                  |               |   | 1                           | Active when input signal is ON (closed). |                                 |                   |               |                |           |  |
|                                  |               |   | 2                           | Active when input signal is OFF (open).  |                                 |                   |               |                |           |  |

Continued on next page.

Continued from previous page.

| Parameter No.  | Size                                     | Name  | Setting Range   | Setting Unit  | Default Setting | Applicable Motors | When Enabled  | Classification | Reference     |                      |                     |                      |                                |            |                                |                               |     |                               |                               |     |                               |                               |     |                               |                                |     |                                |                                |     |                                |                                |     |                                |                                |     |                                |                                |            |                                |                                |     |                                |                                |     |                                |                                |     |                                |                    |        |                    |                                |   |   |  |   |  |   |   |   |                               |   |   |  |
|--|--|---|---|---|-----------------|-------------------|---------------|----------------|---------------|----------------------|---------------------|----------------------|--------------------------------|------------|--------------------------------|-------------------------------|-----|-------------------------------|-------------------------------|-----|-------------------------------|-------------------------------|-----|-------------------------------|--------------------------------|-----|--------------------------------|--------------------------------|-----|--------------------------------|--------------------------------|-----|--------------------------------|--------------------------------|-----|--------------------------------|--------------------------------|------------|--------------------------------|--------------------------------|-----|--------------------------------|--------------------------------|-----|--------------------------------|--------------------------------|-----|--------------------------------|--------------------|--------|--------------------|--------------------------------|---|---|--|---|--|---|---|---|-------------------------------|---|---|--|
| Pn597<br>(A: 2597h,<br>B: 2D97h)   | 2  | FSTP (Forced Stop Input) Signal Allocation  | 0000h to 3029h  | -   | 0000h           | All               | After restart | Setup          | page 7-45     |                      |                     |                      |                                |            |                                |                               |     |                               |                               |     |                               |                               |     |                               |                                |     |                                |                                |     |                                |                                |     |                                |                                |     |                                |                                |            |                                |                                |     |                                |                                |     |                                |                                |     |                                |                    |        |                    |                                |   |   |  |   |  |   |   |   |                               |   |   |  |
|  |  | <table border="1"> <thead> <tr> <th>n.□XXX</th> <th colspan="2">Allocated Pin Number</th> </tr> </thead> <tbody> <tr> <td>000 to 006</td> <td colspan="2">The signal is always inactive.</td> </tr> <tr> <td>007</td> <td colspan="2">Allocate the signal to CN1-7.</td> </tr> <tr> <td>008</td> <td colspan="2">Allocate the signal to CN1-8.</td> </tr> <tr> <td>009</td> <td colspan="2">Allocate the signal to CN1-9.</td> </tr> <tr> <td>010</td> <td colspan="2">Allocate the signal to CN1-10.</td> </tr> <tr> <td>011</td> <td colspan="2">Allocate the signal to CN1-11.</td> </tr> <tr> <td>012</td> <td colspan="2">Allocate the signal to CN1-12.</td> </tr> <tr> <td>013</td> <td colspan="2">Allocate the signal to CN1-13.</td> </tr> <tr> <td>014 to 017</td> <td colspan="2">The signal is always inactive.</td> </tr> <tr> <td>018</td> <td colspan="2">Allocate the signal to CN1-18.</td> </tr> <tr> <td>019</td> <td colspan="2">Allocate the signal to CN1-19.</td> </tr> <tr> <td>020</td> <td colspan="2">Allocate the signal to CN1-20.</td> </tr> <tr> <th>n.X□□□</th> <th colspan="2">Polarity Selection</th> </tr> <tr> <td>0</td> <td colspan="2">Set the signal to always enable drive (always disable forcing the motor to stop).</td> </tr> <tr> <td>1</td> <td colspan="2">Enable drive when the input signal is ON (closed).</td> </tr> <tr> <td>2</td> <td colspan="2">Enable drive when the input signal is OFF (open).</td> </tr> <tr> <td>3</td> <td colspan="2">Set the signal to always prohibit drive (always force the motor to stop).</td> </tr> </tbody> </table> |   |   |                 |                   |               |                |               |                      | n.□XXX              | Allocated Pin Number |                                | 000 to 006 | The signal is always inactive. |                               | 007 | Allocate the signal to CN1-7. |                               | 008 | Allocate the signal to CN1-8. |                               | 009 | Allocate the signal to CN1-9. |                                | 010 | Allocate the signal to CN1-10. |                                | 011 | Allocate the signal to CN1-11. |                                | 012 | Allocate the signal to CN1-12. |                                | 013 | Allocate the signal to CN1-13. |                                | 014 to 017 | The signal is always inactive. |                                | 018 | Allocate the signal to CN1-18. |                                | 019 | Allocate the signal to CN1-19. |                                | 020 | Allocate the signal to CN1-20. |                    | n.X□□□ | Polarity Selection |                                | 0 | Set the signal to always enable drive (always disable forcing the motor to stop). |  | 1 | Enable drive when the input signal is ON (closed). |   | 2 | Enable drive when the input signal is OFF (open). |                               | 3 | Set the signal to always prohibit drive (always force the motor to stop). |  |
|  |  | n.□XXX  | Allocated Pin Number  |   |                 |                   |               |                |               |                      |                     |                      |                                |            |                                |                               |     |                               |                               |     |                               |                               |     |                               |                                |     |                                |                                |     |                                |                                |     |                                |                                |     |                                |                                |            |                                |                                |     |                                |                                |     |                                |                                |     |                                |                    |        |                    |                                |   |   |  |   |  |   |   |   |                               |   |   |  |
|  |  | 000 to 006  | The signal is always inactive.  |   |                 |                   |               |                |               |                      |                     |                      |                                |            |                                |                               |     |                               |                               |     |                               |                               |     |                               |                                |     |                                |                                |     |                                |                                |     |                                |                                |     |                                |                                |            |                                |                                |     |                                |                                |     |                                |                                |     |                                |                    |        |                    |                                |   |   |  |   |  |   |   |   |                               |   |   |  |
|  |  | 007   | Allocate the signal to CN1-7.   |   |                 |                   |               |                |               |                      |                     |                      |                                |            |                                |                               |     |                               |                               |     |                               |                               |     |                               |                                |     |                                |                                |     |                                |                                |     |                                |                                |     |                                |                                |            |                                |                                |     |                                |                                |     |                                |                                |     |                                |                    |        |                    |                                |   |   |  |   |  |   |   |   |                               |   |   |  |
|  |  | 008   | Allocate the signal to CN1-8.   |   |                 |                   |               |                |               |                      |                     |                      |                                |            |                                |                               |     |                               |                               |     |                               |                               |     |                               |                                |     |                                |                                |     |                                |                                |     |                                |                                |     |                                |                                |            |                                |                                |     |                                |                                |     |                                |                                |     |                                |                    |        |                    |                                |   |   |  |   |  |   |   |   |                               |   |   |  |
|  |  | 009   | Allocate the signal to CN1-9.   |   |                 |                   |               |                |               |                      |                     |                      |                                |            |                                |                               |     |                               |                               |     |                               |                               |     |                               |                                |     |                                |                                |     |                                |                                |     |                                |                                |     |                                |                                |            |                                |                                |     |                                |                                |     |                                |                                |     |                                |                    |        |                    |                                |   |   |  |   |  |   |   |   |                               |   |   |  |
|  |  | 010   | Allocate the signal to CN1-10.  |   |                 |                   |               |                |               |                      |                     |                      |                                |            |                                |                               |     |                               |                               |     |                               |                               |     |                               |                                |     |                                |                                |     |                                |                                |     |                                |                                |     |                                |                                |            |                                |                                |     |                                |                                |     |                                |                                |     |                                |                    |        |                    |                                |   |   |  |   |  |   |   |   |                               |   |   |  |
|  |  | 011   | Allocate the signal to CN1-11.  |   |                 |                   |               |                |               |                      |                     |                      |                                |            |                                |                               |     |                               |                               |     |                               |                               |     |                               |                                |     |                                |                                |     |                                |                                |     |                                |                                |     |                                |                                |            |                                |                                |     |                                |                                |     |                                |                                |     |                                |                    |        |                    |                                |   |   |  |   |  |   |   |   |                               |   |   |  |
|  |  | 012   | Allocate the signal to CN1-12.  |   |                 |                   |               |                |               |                      |                     |                      |                                |            |                                |                               |     |                               |                               |     |                               |                               |     |                               |                                |     |                                |                                |     |                                |                                |     |                                |                                |     |                                |                                |            |                                |                                |     |                                |                                |     |                                |                                |     |                                |                    |        |                    |                                |   |   |  |   |  |   |   |   |                               |   |   |  |
|  |  | 013   | Allocate the signal to CN1-13.  |   |                 |                   |               |                |               |                      |                     |                      |                                |            |                                |                               |     |                               |                               |     |                               |                               |     |                               |                                |     |                                |                                |     |                                |                                |     |                                |                                |     |                                |                                |            |                                |                                |     |                                |                                |     |                                |                                |     |                                |                    |        |                    |                                |   |   |  |   |  |   |   |   |                               |   |   |  |
|  |  | 014 to 017  | The signal is always inactive.  |   |                 |                   |               |                |               |                      |                     |                      |                                |            |                                |                               |     |                               |                               |     |                               |                               |     |                               |                                |     |                                |                                |     |                                |                                |     |                                |                                |     |                                |                                |            |                                |                                |     |                                |                                |     |                                |                                |     |                                |                    |        |                    |                                |   |   |  |   |  |   |   |   |                               |   |   |  |
|  |  | 018   | Allocate the signal to CN1-18.  |   |                 |                   |               |                |               |                      |                     |                      |                                |            |                                |                               |     |                               |                               |     |                               |                               |     |                               |                                |     |                                |                                |     |                                |                                |     |                                |                                |     |                                |                                |            |                                |                                |     |                                |                                |     |                                |                                |     |                                |                    |        |                    |                                |   |   |  |   |  |   |   |   |                               |   |   |  |
|  |  | 019   | Allocate the signal to CN1-19.  |   |                 |                   |               |                |               |                      |                     |                      |                                |            |                                |                               |     |                               |                               |     |                               |                               |     |                               |                                |     |                                |                                |     |                                |                                |     |                                |                                |     |                                |                                |            |                                |                                |     |                                |                                |     |                                |                                |     |                                |                    |        |                    |                                |   |   |  |   |  |   |   |   |                               |   |   |  |
|  |  | 020   | Allocate the signal to CN1-20.  |   |                 |                   |               |                |               |                      |                     |                      |                                |            |                                |                               |     |                               |                               |     |                               |                               |     |                               |                                |     |                                |                                |     |                                |                                |     |                                |                                |     |                                |                                |            |                                |                                |     |                                |                                |     |                                |                                |     |                                |                    |        |                    |                                |   |   |  |   |  |   |   |   |                               |   |   |  |
|  |  | n.X□□□  | Polarity Selection  |   |                 |                   |               |                |               |                      |                     |                      |                                |            |                                |                               |     |                               |                               |     |                               |                               |     |                               |                                |     |                                |                                |     |                                |                                |     |                                |                                |     |                                |                                |            |                                |                                |     |                                |                                |     |                                |                                |     |                                |                    |        |                    |                                |   |   |  |   |  |   |   |   |                               |   |   |  |
|  |  | 0   | Set the signal to always enable drive (always disable forcing the motor to stop). |   |                 |                   |               |                |               |                      |                     |                      |                                |            |                                |                               |     |                               |                               |     |                               |                               |     |                               |                                |     |                                |                                |     |                                |                                |     |                                |                                |     |                                |                                |            |                                |                                |     |                                |                                |     |                                |                                |     |                                |                    |        |                    |                                |   |   |  |   |  |   |   |   |                               |   |   |  |
|  |  | 1   | Enable drive when the input signal is ON (closed).                                |   |                 |                   |               |                |               |                      |                     |                      |                                |            |                                |                               |     |                               |                               |     |                               |                               |     |                               |                                |     |                                |                                |     |                                |                                |     |                                |                                |     |                                |                                |            |                                |                                |     |                                |                                |     |                                |                                |     |                                |                    |        |                    |                                |   |   |  |   |  |   |   |   |                               |   |   |  |
|  |  | 2   | Enable drive when the input signal is OFF (open).                                 |   |                 |                   |               |                |               |                      |                     |                      |                                |            |                                |                               |     |                               |                               |     |                               |                               |     |                               |                                |     |                                |                                |     |                                |                                |     |                                |                                |     |                                |                                |            |                                |                                |     |                                |                                |     |                                |                                |     |                                |                    |        |                    |                                |   |   |  |   |  |   |   |   |                               |   |   |  |
|  |  | 3   | Set the signal to always prohibit drive (always force the motor to stop).         |   |                 |                   |               |                |               |                      |                     |                      |                                |            |                                |                               |     |                               |                               |     |                               |                               |     |                               |                                |     |                                |                                |     |                                |                                |     |                                |                                |     |                                |                                |            |                                |                                |     |                                |                                |     |                                |                                |     |                                |                    |        |                    |                                |   |   |  |   |  |   |   |   |                               |   |   |  |
|  |  | Pn598<br>(A: 2598h,<br>B: 2D98h)  | 2   | /P-CL (Forward External Torque Limit Input) Signal Allocation | 0000h to 3029h  | -                 | 0000h         | All            | After restart | Setup                | page 7-3, page 7-24 |                      |                                |            |                                |                               |     |                               |                               |     |                               |                               |     |                               |                                |     |                                |                                |     |                                |                                |     |                                |                                |     |                                |                                |            |                                |                                |     |                                |                                |     |                                |                                |     |                                |                    |        |                    |                                |   |   |  |   |  |   |   |   |                               |   |   |  |
| <table border="1"> <thead> <tr> <th>n.□XXX</th> <th colspan="2">Allocated Pin Number</th> </tr> </thead> <tbody> <tr> <td>000 to 006</td> <td colspan="2">The signal is always inactive.</td> </tr> <tr> <td>007</td> <td colspan="2">Allocate the signal to CN1-7.</td> </tr> <tr> <td>008</td> <td colspan="2">Allocate the signal to CN1-8.</td> </tr> <tr> <td>009</td> <td colspan="2">Allocate the signal to CN1-9.</td> </tr> <tr> <td>010</td> <td colspan="2">Allocate the signal to CN1-10.</td> </tr> <tr> <td>011</td> <td colspan="2">Allocate the signal to CN1-11.</td> </tr> <tr> <td>012</td> <td colspan="2">Allocate the signal to CN1-12.</td> </tr> <tr> <td>013</td> <td colspan="2">Allocate the signal to CN1-13.</td> </tr> <tr> <td>014 to 017</td> <td colspan="2">The signal is always inactive.</td> </tr> <tr> <td>018</td> <td colspan="2">Allocate the signal to CN1-18.</td> </tr> <tr> <td>019</td> <td colspan="2">Allocate the signal to CN1-19.</td> </tr> <tr> <td>020</td> <td colspan="2">Allocate the signal to CN1-20.</td> </tr> <tr> <th>n.X□□□</th> <th colspan="2">Polarity Selection</th> </tr> <tr> <td>0</td> <td colspan="2">The signal is always inactive.</td> </tr> <tr> <td>1</td> <td colspan="2">Active when input signal is ON (closed).</td> </tr> <tr> <td>2</td> <td colspan="2">Active when input signal is OFF (open).</td> </tr> <tr> <td>3</td> <td colspan="2">The signal is always enabled.</td> </tr> </tbody> </table> |  |   |   |   |                 |                   |               |                | n.□XXX        | Allocated Pin Number |                     | 000 to 006           | The signal is always inactive. |            | 007                            | Allocate the signal to CN1-7. |     | 008                           | Allocate the signal to CN1-8. |     | 009                           | Allocate the signal to CN1-9. |     | 010                           | Allocate the signal to CN1-10. |     | 011                            | Allocate the signal to CN1-11. |     | 012                            | Allocate the signal to CN1-12. |     | 013                            | Allocate the signal to CN1-13. |     | 014 to 017                     | The signal is always inactive. |            | 018                            | Allocate the signal to CN1-18. |     | 019                            | Allocate the signal to CN1-19. |     | 020                            | Allocate the signal to CN1-20. |     | n.X□□□                         | Polarity Selection |        | 0                  | The signal is always inactive. |   | 1   | Active when input signal is ON (closed). |   | 2  | Active when input signal is OFF (open). |   | 3   | The signal is always enabled. |   |   |  |
| n.□XXX   | Allocated Pin Number                     |   |   |   |                 |                   |               |                |               |                      |                     |                      |                                |            |                                |                               |     |                               |                               |     |                               |                               |     |                               |                                |     |                                |                                |     |                                |                                |     |                                |                                |     |                                |                                |            |                                |                                |     |                                |                                |     |                                |                                |     |                                |                    |        |                    |                                |   |   |  |   |  |   |   |   |                               |   |   |  |
| 000 to 006   | The signal is always inactive.           |   |   |   |                 |                   |               |                |               |                      |                     |                      |                                |            |                                |                               |     |                               |                               |     |                               |                               |     |                               |                                |     |                                |                                |     |                                |                                |     |                                |                                |     |                                |                                |            |                                |                                |     |                                |                                |     |                                |                                |     |                                |                    |        |                    |                                |   |   |  |   |  |   |   |   |                               |   |   |  |
| 007  | Allocate the signal to CN1-7.            |   |   |   |                 |                   |               |                |               |                      |                     |                      |                                |            |                                |                               |     |                               |                               |     |                               |                               |     |                               |                                |     |                                |                                |     |                                |                                |     |                                |                                |     |                                |                                |            |                                |                                |     |                                |                                |     |                                |                                |     |                                |                    |        |                    |                                |   |   |  |   |  |   |   |   |                               |   |   |  |
| 008  | Allocate the signal to CN1-8.            |   |   |   |                 |                   |               |                |               |                      |                     |                      |                                |            |                                |                               |     |                               |                               |     |                               |                               |     |                               |                                |     |                                |                                |     |                                |                                |     |                                |                                |     |                                |                                |            |                                |                                |     |                                |                                |     |                                |                                |     |                                |                    |        |                    |                                |   |   |  |   |  |   |   |   |                               |   |   |  |
| 009  | Allocate the signal to CN1-9.            |   |   |   |                 |                   |               |                |               |                      |                     |                      |                                |            |                                |                               |     |                               |                               |     |                               |                               |     |                               |                                |     |                                |                                |     |                                |                                |     |                                |                                |     |                                |                                |            |                                |                                |     |                                |                                |     |                                |                                |     |                                |                    |        |                    |                                |   |   |  |   |  |   |   |   |                               |   |   |  |
| 010  | Allocate the signal to CN1-10.           |   |   |   |                 |                   |               |                |               |                      |                     |                      |                                |            |                                |                               |     |                               |                               |     |                               |                               |     |                               |                                |     |                                |                                |     |                                |                                |     |                                |                                |     |                                |                                |            |                                |                                |     |                                |                                |     |                                |                                |     |                                |                    |        |                    |                                |   |   |  |   |  |   |   |   |                               |   |   |  |
| 011  | Allocate the signal to CN1-11.           |   |   |   |                 |                   |               |                |               |                      |                     |                      |                                |            |                                |                               |     |                               |                               |     |                               |                               |     |                               |                                |     |                                |                                |     |                                |                                |     |                                |                                |     |                                |                                |            |                                |                                |     |                                |                                |     |                                |                                |     |                                |                    |        |                    |                                |   |   |  |   |  |   |   |   |                               |   |   |  |
| 012  | Allocate the signal to CN1-12.           |   |   |   |                 |                   |               |                |               |                      |                     |                      |                                |            |                                |                               |     |                               |                               |     |                               |                               |     |                               |                                |     |                                |                                |     |                                |                                |     |                                |                                |     |                                |                                |            |                                |                                |     |                                |                                |     |                                |                                |     |                                |                    |        |                    |                                |   |   |  |   |  |   |   |   |                               |   |   |  |
| 013  | Allocate the signal to CN1-13.           |   |   |   |                 |                   |               |                |               |                      |                     |                      |                                |            |                                |                               |     |                               |                               |     |                               |                               |     |                               |                                |     |                                |                                |     |                                |                                |     |                                |                                |     |                                |                                |            |                                |                                |     |                                |                                |     |                                |                                |     |                                |                    |        |                    |                                |   |   |  |   |  |   |   |   |                               |   |   |  |
| 014 to 017   | The signal is always inactive.           |   |   |   |                 |                   |               |                |               |                      |                     |                      |                                |            |                                |                               |     |                               |                               |     |                               |                               |     |                               |                                |     |                                |                                |     |                                |                                |     |                                |                                |     |                                |                                |            |                                |                                |     |                                |                                |     |                                |                                |     |                                |                    |        |                    |                                |   |   |  |   |  |   |   |   |                               |   |   |  |
| 018  | Allocate the signal to CN1-18.           |   |   |   |                 |                   |               |                |               |                      |                     |                      |                                |            |                                |                               |     |                               |                               |     |                               |                               |     |                               |                                |     |                                |                                |     |                                |                                |     |                                |                                |     |                                |                                |            |                                |                                |     |                                |                                |     |                                |                                |     |                                |                    |        |                    |                                |   |   |  |   |  |   |   |   |                               |   |   |  |
| 019  | Allocate the signal to CN1-19.           |   |   |   |                 |                   |               |                |               |                      |                     |                      |                                |            |                                |                               |     |                               |                               |     |                               |                               |     |                               |                                |     |                                |                                |     |                                |                                |     |                                |                                |     |                                |                                |            |                                |                                |     |                                |                                |     |                                |                                |     |                                |                    |        |                    |                                |   |   |  |   |  |   |   |   |                               |   |   |  |
| 020  | Allocate the signal to CN1-20.           |   |   |   |                 |                   |               |                |               |                      |                     |                      |                                |            |                                |                               |     |                               |                               |     |                               |                               |     |                               |                                |     |                                |                                |     |                                |                                |     |                                |                                |     |                                |                                |            |                                |                                |     |                                |                                |     |                                |                                |     |                                |                    |        |                    |                                |   |   |  |   |  |   |   |   |                               |   |   |  |
| n.X□□□   | Polarity Selection                       |   |   |   |                 |                   |               |                |               |                      |                     |                      |                                |            |                                |                               |     |                               |                               |     |                               |                               |     |                               |                                |     |                                |                                |     |                                |                                |     |                                |                                |     |                                |                                |            |                                |                                |     |                                |                                |     |                                |                                |     |                                |                    |        |                    |                                |   |   |  |   |  |   |   |   |                               |   |   |  |
| 0  | The signal is always inactive.           |   |   |   |                 |                   |               |                |               |                      |                     |                      |                                |            |                                |                               |     |                               |                               |     |                               |                               |     |                               |                                |     |                                |                                |     |                                |                                |     |                                |                                |     |                                |                                |            |                                |                                |     |                                |                                |     |                                |                                |     |                                |                    |        |                    |                                |   |   |  |   |  |   |   |   |                               |   |   |  |
| 1  | Active when input signal is ON (closed). |   |   |   |                 |                   |               |                |               |                      |                     |                      |                                |            |                                |                               |     |                               |                               |     |                               |                               |     |                               |                                |     |                                |                                |     |                                |                                |     |                                |                                |     |                                |                                |            |                                |                                |     |                                |                                |     |                                |                                |     |                                |                    |        |                    |                                |   |   |  |   |  |   |   |   |                               |   |   |  |
| 2  | Active when input signal is OFF (open).  |   |   |   |                 |                   |               |                |               |                      |                     |                      |                                |            |                                |                               |     |                               |                               |     |                               |                               |     |                               |                                |     |                                |                                |     |                                |                                |     |                                |                                |     |                                |                                |            |                                |                                |     |                                |                                |     |                                |                                |     |                                |                    |        |                    |                                |   |   |  |   |  |   |   |   |                               |   |   |  |
| 3  | The signal is always enabled.            |   |   |   |                 |                   |               |                |               |                      |                     |                      |                                |            |                                |                               |     |                               |                               |     |                               |                               |     |                               |                                |     |                                |                                |     |                                |                                |     |                                |                                |     |                                |                                |            |                                |                                |     |                                |                                |     |                                |                                |     |                                |                    |        |                    |                                |   |   |  |   |  |   |   |   |                               |   |   |  |

Continued on next page.

16.1 List of Servo Parameters

16.1.2 List of Parameters

Continued from previous page.

| Parameter No.                    | Size   | Name  | Setting Range  | Setting Unit | Default Setting | Applicable Motors | When Enabled  | Classification | Reference           |        |                      |  |            |                                |  |     |                                |  |     |                                |  |     |                                |  |     |                                |  |        |                                |  |     |   |  |     |                                |  |            |  |  |     |                                |  |     |                                |  |     |                                |  |        |                    |  |   |                                |  |   |  |  |   |   |  |   |                              |  |
|----------------------------------|--|---|----------------|--------------|-----------------|-------------------|---------------|----------------|---------------------|--------|----------------------|--|------------|--------------------------------|--|-----|--------------------------------|--|-----|--------------------------------|--|-----|--------------------------------|--|-----|--------------------------------|--|--------|--------------------------------|--|-----|---|--|-----|--------------------------------|--|------------|--|--|-----|--------------------------------|--|-----|--------------------------------|--|-----|--------------------------------|--|--------|--------------------|--|---|--------------------------------|--|---|--|--|---|---|--|---|------------------------------|--|
| Pn599<br>(A: 2599h,<br>B: 2D99h) | 2  | /N-CL (Reverse External Torque Limit Input) Signal Allocation | 0000h to 3029h | -            | 0000h           | All               | After restart | Setup          | page 7-3, page 7-24 |        |                      |  |            |                                |  |     |                                |  |     |                                |  |     |                                |  |     |                                |  |        |                                |  |     |   |  |     |                                |  |            |  |  |     |                                |  |     |                                |  |     |                                |  |        |                    |  |   |                                |  |   |  |  |   |   |  |   |                              |  |
|                                  | <table border="1"> <thead> <tr> <th>n.□XXX</th> <th colspan="2">Allocated Pin Number</th> </tr> </thead> <tbody> <tr> <td>000 to 006</td> <td colspan="2">The signal is always inactive.</td> </tr> <tr> <td>007</td> <td colspan="2">Allocate the signal to CN1-7.</td> </tr> <tr> <td>008</td> <td colspan="2">Allocate the signal to CN1-8.</td> </tr> <tr> <td>009</td> <td colspan="2">Allocate the signal to CN1-9.</td> </tr> <tr> <td>010</td> <td colspan="2">Allocate the signal to CN1-10.</td> </tr> <tr> <td>011</td> <td colspan="2">Allocate the signal to CN1-11.</td> </tr> <tr> <td>012</td> <td colspan="2">Allocate the signal to CN1-12.</td> </tr> <tr> <td>013</td> <td colspan="2">Allocate the signal to CN1-13.</td> </tr> <tr> <td>014 to 017</td> <td colspan="2">The signal is always inactive.</td> </tr> <tr> <td>018</td> <td colspan="2">Allocate the signal to CN1-18.</td> </tr> <tr> <td>019</td> <td colspan="2">Allocate the signal to CN1-19.</td> </tr> <tr> <td>020</td> <td colspan="2">Allocate the signal to CN1-20.</td> </tr> </tbody> </table><br><table border="1"> <thead> <tr> <th>n.X□□□</th> <th colspan="2">Polarity Selection</th> </tr> </thead> <tbody> <tr> <td>0</td> <td colspan="2">The signal is always inactive.</td> </tr> <tr> <td>1</td> <td colspan="2">Active when input signal is ON (closed).</td> </tr> <tr> <td>2</td> <td colspan="2">Active when input signal is OFF (open).</td> </tr> <tr> <td>3</td> <td colspan="2">The signal is always active.</td> </tr> </tbody> </table> |   |                |              |                 |                   |               |                |                     | n.□XXX | Allocated Pin Number |  | 000 to 006 | The signal is always inactive. |  | 007 | Allocate the signal to CN1-7.  |  | 008 | Allocate the signal to CN1-8.  |  | 009 | Allocate the signal to CN1-9.  |  | 010 | Allocate the signal to CN1-10. |  | 011    | Allocate the signal to CN1-11. |  | 012 | Allocate the signal to CN1-12.                  |  | 013 | Allocate the signal to CN1-13. |  | 014 to 017 | The signal is always inactive.         |  | 018 | Allocate the signal to CN1-18. |  | 019 | Allocate the signal to CN1-19. |  | 020 | Allocate the signal to CN1-20. |  | n.X□□□ | Polarity Selection |  | 0 | The signal is always inactive. |  | 1 | Active when input signal is ON (closed). |  | 2 | Active when input signal is OFF (open). |  | 3 | The signal is always active. |  |
|                                  | n.□XXX   | Allocated Pin Number  |                |              |                 |                   |               |                |                     |        |                      |  |            |                                |  |     |                                |  |     |                                |  |     |                                |  |     |                                |  |        |                                |  |     |   |  |     |                                |  |            |  |  |     |                                |  |     |                                |  |     |                                |  |        |                    |  |   |                                |  |   |  |  |   |   |  |   |                              |  |
|                                  | 000 to 006   | The signal is always inactive.                                |                |              |                 |                   |               |                |                     |        |                      |  |            |                                |  |     |                                |  |     |                                |  |     |                                |  |     |                                |  |        |                                |  |     |   |  |     |                                |  |            |  |  |     |                                |  |     |                                |  |     |                                |  |        |                    |  |   |                                |  |   |  |  |   |   |  |   |                              |  |
|                                  | 007  | Allocate the signal to CN1-7.                                 |                |              |                 |                   |               |                |                     |        |                      |  |            |                                |  |     |                                |  |     |                                |  |     |                                |  |     |                                |  |        |                                |  |     |   |  |     |                                |  |            |  |  |     |                                |  |     |                                |  |     |                                |  |        |                    |  |   |                                |  |   |  |  |   |   |  |   |                              |  |
|                                  | 008  | Allocate the signal to CN1-8.                                 |                |              |                 |                   |               |                |                     |        |                      |  |            |                                |  |     |                                |  |     |                                |  |     |                                |  |     |                                |  |        |                                |  |     |   |  |     |                                |  |            |  |  |     |                                |  |     |                                |  |     |                                |  |        |                    |  |   |                                |  |   |  |  |   |   |  |   |                              |  |
|                                  | 009  | Allocate the signal to CN1-9.                                 |                |              |                 |                   |               |                |                     |        |                      |  |            |                                |  |     |                                |  |     |                                |  |     |                                |  |     |                                |  |        |                                |  |     |   |  |     |                                |  |            |  |  |     |                                |  |     |                                |  |     |                                |  |        |                    |  |   |                                |  |   |  |  |   |   |  |   |                              |  |
|                                  | 010  | Allocate the signal to CN1-10.                                |                |              |                 |                   |               |                |                     |        |                      |  |            |                                |  |     |                                |  |     |                                |  |     |                                |  |     |                                |  |        |                                |  |     |   |  |     |                                |  |            |  |  |     |                                |  |     |                                |  |     |                                |  |        |                    |  |   |                                |  |   |  |  |   |   |  |   |                              |  |
|                                  | 011  | Allocate the signal to CN1-11.                                |                |              |                 |                   |               |                |                     |        |                      |  |            |                                |  |     |                                |  |     |                                |  |     |                                |  |     |                                |  |        |                                |  |     |   |  |     |                                |  |            |  |  |     |                                |  |     |                                |  |     |                                |  |        |                    |  |   |                                |  |   |  |  |   |   |  |   |                              |  |
|                                  | 012  | Allocate the signal to CN1-12.                                |                |              |                 |                   |               |                |                     |        |                      |  |            |                                |  |     |                                |  |     |                                |  |     |                                |  |     |                                |  |        |                                |  |     |   |  |     |                                |  |            |  |  |     |                                |  |     |                                |  |     |                                |  |        |                    |  |   |                                |  |   |  |  |   |   |  |   |                              |  |
|                                  | 013  | Allocate the signal to CN1-13.                                |                |              |                 |                   |               |                |                     |        |                      |  |            |                                |  |     |                                |  |     |                                |  |     |                                |  |     |                                |  |        |                                |  |     |   |  |     |                                |  |            |  |  |     |                                |  |     |                                |  |     |                                |  |        |                    |  |   |                                |  |   |  |  |   |   |  |   |                              |  |
|                                  | 014 to 017   | The signal is always inactive.                                |                |              |                 |                   |               |                |                     |        |                      |  |            |                                |  |     |                                |  |     |                                |  |     |                                |  |     |                                |  |        |                                |  |     |   |  |     |                                |  |            |  |  |     |                                |  |     |                                |  |     |                                |  |        |                    |  |   |                                |  |   |  |  |   |   |  |   |                              |  |
|                                  | 018  | Allocate the signal to CN1-18.                                |                |              |                 |                   |               |                |                     |        |                      |  |            |                                |  |     |                                |  |     |                                |  |     |                                |  |     |                                |  |        |                                |  |     |   |  |     |                                |  |            |  |  |     |                                |  |     |                                |  |     |                                |  |        |                    |  |   |                                |  |   |  |  |   |   |  |   |                              |  |
|                                  | 019  | Allocate the signal to CN1-19.                                |                |              |                 |                   |               |                |                     |        |                      |  |            |                                |  |     |                                |  |     |                                |  |     |                                |  |     |                                |  |        |                                |  |     |   |  |     |                                |  |            |  |  |     |                                |  |     |                                |  |     |                                |  |        |                    |  |   |                                |  |   |  |  |   |   |  |   |                              |  |
|                                  | 020  | Allocate the signal to CN1-20.                                |                |              |                 |                   |               |                |                     |        |                      |  |            |                                |  |     |                                |  |     |                                |  |     |                                |  |     |                                |  |        |                                |  |     |   |  |     |                                |  |            |  |  |     |                                |  |     |                                |  |     |                                |  |        |                    |  |   |                                |  |   |  |  |   |   |  |   |                              |  |
|                                  | n.X□□□   | Polarity Selection  |                |              |                 |                   |               |                |                     |        |                      |  |            |                                |  |     |                                |  |     |                                |  |     |                                |  |     |                                |  |        |                                |  |     |   |  |     |                                |  |            |  |  |     |                                |  |     |                                |  |     |                                |  |        |                    |  |   |                                |  |   |  |  |   |   |  |   |                              |  |
|                                  | 0  | The signal is always inactive.                                |                |              |                 |                   |               |                |                     |        |                      |  |            |                                |  |     |                                |  |     |                                |  |     |                                |  |     |                                |  |        |                                |  |     |   |  |     |                                |  |            |  |  |     |                                |  |     |                                |  |     |                                |  |        |                    |  |   |                                |  |   |  |  |   |   |  |   |                              |  |
|                                  | 1  | Active when input signal is ON (closed).                      |                |              |                 |                   |               |                |                     |        |                      |  |            |                                |  |     |                                |  |     |                                |  |     |                                |  |     |                                |  |        |                                |  |     |   |  |     |                                |  |            |  |  |     |                                |  |     |                                |  |     |                                |  |        |                    |  |   |                                |  |   |  |  |   |   |  |   |                              |  |
|                                  | 2  | Active when input signal is OFF (open).                       |                |              |                 |                   |               |                |                     |        |                      |  |            |                                |  |     |                                |  |     |                                |  |     |                                |  |     |                                |  |        |                                |  |     |   |  |     |                                |  |            |  |  |     |                                |  |     |                                |  |     |                                |  |        |                    |  |   |                                |  |   |  |  |   |   |  |   |                              |  |
|                                  | 3  | The signal is always active.                                  |                |              |                 |                   |               |                |                     |        |                      |  |            |                                |  |     |                                |  |     |                                |  |     |                                |  |     |                                |  |        |                                |  |     |   |  |     |                                |  |            |  |  |     |                                |  |     |                                |  |     |                                |  |        |                    |  |   |                                |  |   |  |  |   |   |  |   |                              |  |
| Pn5B0<br>(A: 25B0h,<br>B: 2DB0h) | 2  | /COIN (Positioning Completion Output) Signal Allocation       | 0000h to 2039h | -            | 0000h           | All               | After restart | Setup          | page 7-3, page 7-14 |        |                      |  |            |                                |  |     |                                |  |     |                                |  |     |                                |  |     |                                |  |        |                                |  |     |   |  |     |                                |  |            |  |  |     |                                |  |     |                                |  |     |                                |  |        |                    |  |   |                                |  |   |  |  |   |   |  |   |                              |  |
|                                  | <table border="1"> <thead> <tr> <th>n.□XXX</th> <th colspan="2">Allocated Pin Number</th> </tr> </thead> <tbody> <tr> <td>001</td> <td colspan="2">Allocate the signal to CN1-1.</td> </tr> <tr> <td>023</td> <td colspan="2">Allocate the signal to CN1-23.</td> </tr> <tr> <td>025</td> <td colspan="2">Allocate the signal to CN1-25.</td> </tr> <tr> <td>027</td> <td colspan="2">Allocate the signal to CN1-27.</td> </tr> <tr> <td>029</td> <td colspan="2">Allocate the signal to CN1-29.</td> </tr> </tbody> </table><br><table border="1"> <thead> <tr> <th>n.X□□□</th> <th colspan="2">Polarity Selection</th> </tr> </thead> <tbody> <tr> <td>0</td> <td colspan="2">Disabled (the above signal output is not used).</td> </tr> <tr> <td>1</td> <td colspan="2">Output the above signal.</td> </tr> <tr> <td>2</td> <td colspan="2">Invert the above signal and output it.</td> </tr> </tbody> </table>   |   |                |              |                 |                   |               |                |                     | n.□XXX | Allocated Pin Number |  | 001        | Allocate the signal to CN1-1.  |  | 023 | Allocate the signal to CN1-23. |  | 025 | Allocate the signal to CN1-25. |  | 027 | Allocate the signal to CN1-27. |  | 029 | Allocate the signal to CN1-29. |  | n.X□□□ | Polarity Selection             |  | 0   | Disabled (the above signal output is not used). |  | 1   | Output the above signal.       |  | 2          | Invert the above signal and output it. |  |     |                                |  |     |                                |  |     |                                |  |        |                    |  |   |                                |  |   |  |  |   |   |  |   |                              |  |
|                                  | n.□XXX   | Allocated Pin Number  |                |              |                 |                   |               |                |                     |        |                      |  |            |                                |  |     |                                |  |     |                                |  |     |                                |  |     |                                |  |        |                                |  |     |   |  |     |                                |  |            |  |  |     |                                |  |     |                                |  |     |                                |  |        |                    |  |   |                                |  |   |  |  |   |   |  |   |                              |  |
|                                  | 001  | Allocate the signal to CN1-1.                                 |                |              |                 |                   |               |                |                     |        |                      |  |            |                                |  |     |                                |  |     |                                |  |     |                                |  |     |                                |  |        |                                |  |     |   |  |     |                                |  |            |  |  |     |                                |  |     |                                |  |     |                                |  |        |                    |  |   |                                |  |   |  |  |   |   |  |   |                              |  |
|                                  | 023  | Allocate the signal to CN1-23.                                |                |              |                 |                   |               |                |                     |        |                      |  |            |                                |  |     |                                |  |     |                                |  |     |                                |  |     |                                |  |        |                                |  |     |   |  |     |                                |  |            |  |  |     |                                |  |     |                                |  |     |                                |  |        |                    |  |   |                                |  |   |  |  |   |   |  |   |                              |  |
|                                  | 025  | Allocate the signal to CN1-25.                                |                |              |                 |                   |               |                |                     |        |                      |  |            |                                |  |     |                                |  |     |                                |  |     |                                |  |     |                                |  |        |                                |  |     |   |  |     |                                |  |            |  |  |     |                                |  |     |                                |  |     |                                |  |        |                    |  |   |                                |  |   |  |  |   |   |  |   |                              |  |
|                                  | 027  | Allocate the signal to CN1-27.                                |                |              |                 |                   |               |                |                     |        |                      |  |            |                                |  |     |                                |  |     |                                |  |     |                                |  |     |                                |  |        |                                |  |     |   |  |     |                                |  |            |  |  |     |                                |  |     |                                |  |     |                                |  |        |                    |  |   |                                |  |   |  |  |   |   |  |   |                              |  |
|                                  | 029  | Allocate the signal to CN1-29.                                |                |              |                 |                   |               |                |                     |        |                      |  |            |                                |  |     |                                |  |     |                                |  |     |                                |  |     |                                |  |        |                                |  |     |   |  |     |                                |  |            |  |  |     |                                |  |     |                                |  |     |                                |  |        |                    |  |   |                                |  |   |  |  |   |   |  |   |                              |  |
|                                  | n.X□□□   | Polarity Selection  |                |              |                 |                   |               |                |                     |        |                      |  |            |                                |  |     |                                |  |     |                                |  |     |                                |  |     |                                |  |        |                                |  |     |   |  |     |                                |  |            |  |  |     |                                |  |     |                                |  |     |                                |  |        |                    |  |   |                                |  |   |  |  |   |   |  |   |                              |  |
|                                  | 0  | Disabled (the above signal output is not used).               |                |              |                 |                   |               |                |                     |        |                      |  |            |                                |  |     |                                |  |     |                                |  |     |                                |  |     |                                |  |        |                                |  |     |   |  |     |                                |  |            |  |  |     |                                |  |     |                                |  |     |                                |  |        |                    |  |   |                                |  |   |  |  |   |   |  |   |                              |  |
| 1                                | Output the above signal.   |   |                |              |                 |                   |               |                |                     |        |                      |  |            |                                |  |     |                                |  |     |                                |  |     |                                |  |     |                                |  |        |                                |  |     |   |  |     |                                |  |            |  |  |     |                                |  |     |                                |  |     |                                |  |        |                    |  |   |                                |  |   |  |  |   |   |  |   |                              |  |
| 2                                | Invert the above signal and output it.   |   |                |              |                 |                   |               |                |                     |        |                      |  |            |                                |  |     |                                |  |     |                                |  |     |                                |  |     |                                |  |        |                                |  |     |   |  |     |                                |  |            |  |  |     |                                |  |     |                                |  |     |                                |  |        |                    |  |   |                                |  |   |  |  |   |   |  |   |                              |  |

Continued on next page.



Continued from previous page.

| Parameter No.                    | Size          | Name  | Setting Range               | Setting Unit                                    | Default Setting | Applicable Motors | When Enabled  | Classification | Reference           |  |
|----------------------------------|---------------|---|-----------------------------|---|-----------------|-------------------|---------------|----------------|---------------------|--|
| Pn5B1<br>(A: 25B1h,<br>B: 2DB1h) | 2             | /V-CMP (Speed Coincidence Detection Output) Signal Allocation | 0000h to 2039h              | –   | 0000h           | All               | After restart | Setup          | page 7-3, page 7-12 |  |
|                                  | <b>n.□XXX</b> |   | <b>Allocated Pin Number</b> |   |                 |                   |               |                |                     |  |
|                                  |               |   | 001                         | Allocate the signal to CN1-1.                   |                 |                   |               |                |                     |  |
|                                  |               |   | 023                         | Allocate the signal to CN1-23.                  |                 |                   |               |                |                     |  |
|                                  |               |   | 025                         | Allocate the signal to CN1-25.                  |                 |                   |               |                |                     |  |
|                                  |               |   | 027                         | Allocate the signal to CN1-27.                  |                 |                   |               |                |                     |  |
|                                  |               |   | 029                         | Allocate the signal to CN1-29.                  |                 |                   |               |                |                     |  |
|                                  | <b>n.X□□□</b> |   | <b>Polarity Selection</b>   |   |                 |                   |               |                |                     |  |
|                                  |               |   | 0                           | Disabled (the above signal output is not used). |                 |                   |               |                |                     |  |
|                                  |               |   | 1                           | Output the above signal.                        |                 |                   |               |                |                     |  |
|                                  |               |   | 2                           | Invert the above signal and output it.          |                 |                   |               |                |                     |  |
| Pn5B2<br>(A: 25B2h,<br>B: 2DB2h) | 2             | /TGON (Rotation Detection Output) Signal Allocation           | 0000h to 2039h              | –   | 0000h           | All               | After restart | Setup          | page 7-3, page 7-11 |  |
|                                  | <b>n.□XXX</b> |   | <b>Allocated Pin Number</b> |   |                 |                   |               |                |                     |  |
|                                  |               |   | 001                         | Allocate the signal to CN1-1.                   |                 |                   |               |                |                     |  |
|                                  |               |   | 023                         | Allocate the signal to CN1-23.                  |                 |                   |               |                |                     |  |
|                                  |               |   | 025                         | Allocate the signal to CN1-25.                  |                 |                   |               |                |                     |  |
|                                  |               |   | 027                         | Allocate the signal to CN1-27.                  |                 |                   |               |                |                     |  |
|                                  |               |   | 029                         | Allocate the signal to CN1-29.                  |                 |                   |               |                |                     |  |
|                                  | <b>n.X□□□</b> |   | <b>Polarity Selection</b>   |   |                 |                   |               |                |                     |  |
|                                  |               |   | 0                           | Disabled (the above signal output is not used). |                 |                   |               |                |                     |  |
|                                  |               |   | 1                           | Output the above signal.                        |                 |                   |               |                |                     |  |
|                                  |               |   | 2                           | Invert the above signal and output it.          |                 |                   |               |                |                     |  |
| Pn5B3<br>(A: 25B3h,<br>B: 2DB3h) | 2             | /S-RDY (Servo Ready) Signal Allocation                        | 0000h to 2039h              | –   | 0000h           | All               | After restart | Setup          | page 7-3, page 7-12 |  |
|                                  | <b>n.□XXX</b> |   | <b>Allocated Pin Number</b> |   |                 |                   |               |                |                     |  |
|                                  |               |   | 001                         | Allocate the signal to CN1-1.                   |                 |                   |               |                |                     |  |
|                                  |               |   | 023                         | Allocate the signal to CN1-23.                  |                 |                   |               |                |                     |  |
|                                  |               |   | 025                         | Allocate the signal to CN1-25.                  |                 |                   |               |                |                     |  |
|                                  |               |   | 027                         | Allocate the signal to CN1-27.                  |                 |                   |               |                |                     |  |
|                                  |               |   | 029                         | Allocate the signal to CN1-29.                  |                 |                   |               |                |                     |  |
|                                  | <b>n.X□□□</b> |   | <b>Polarity Selection</b>   |   |                 |                   |               |                |                     |  |
|                                  |               |   | 0                           | Disabled (the above signal output is not used). |                 |                   |               |                |                     |  |
|                                  |               |   | 1                           | Output the above signal.                        |                 |                   |               |                |                     |  |
|                                  |               |   | 2                           | Invert the above signal and output it.          |                 |                   |               |                |                     |  |

Continued on next page.

16.1 List of Servo Parameters

16.1.2 List of Parameters

Continued from previous page.

| Parameter No.                    | Size   | Name   | Setting Range                                   | Setting Unit | Default Setting              | Applicable Motors | When Enabled  | Classification | Reference           |  |
|----------------------------------|--------|--|---|--------------|------------------------------|-------------------|---------------|----------------|---------------------|--|
| Pn5B4<br>(A: 25B4h,<br>B: 2DB4h) | 2      | /CLT (Torque Limit Detection Output) Signal Allocation | 0000h to 2039h                                  | -            | 0000h                        | All               | After restart | Setup          | page 7-3, page 7-27 |  |
|                                  | n.□XXX |  | Allocated Pin Number                            |              |                              |                   |               |                |                     |  |
|                                  | 001    |  | Allocate the signal to CN1-1.                   |              |                              |                   |               |                |                     |  |
|                                  | 023    |  | Allocate the signal to CN1-23.                  |              |                              |                   |               |                |                     |  |
|                                  | 025    |  | Allocate the signal to CN1-25.                  |              |                              |                   |               |                |                     |  |
|                                  | 027    |  | Allocate the signal to CN1-27.                  |              |                              |                   |               |                |                     |  |
|                                  | 029    |  | Allocate the signal to CN1-29.                  |              |                              |                   |               |                |                     |  |
|                                  | n.X□□□ |  | Polarity Selection                              |              |                              |                   |               |                |                     |  |
|                                  | 0      |  | Disabled (the above signal output is not used). |              |                              |                   |               |                |                     |  |
|                                  | 1      |  | Output the above signal.                        |              |                              |                   |               |                |                     |  |
| 2                                |        | Invert the above signal and output it.                 |   |              |                              |                   |               |                |                     |  |
| Pn5B5<br>(A: 25B5h,<br>B: 2DB5h) | 2      | /MLT (Speed Limit Detection) Signal Allocation         | 0000h to 2039h                                  | -            | 0000h                        | All               | After restart | Setup          | page 7-3, page 7-16 |  |
|                                  | n.□XXX |  | Allocated Pin Number                            |              |                              |                   |               |                |                     |  |
|                                  | 001    |  | Allocate the signal to CN1-1.                   |              |                              |                   |               |                |                     |  |
|                                  | 023    |  | Allocate the signal to CN1-23.                  |              |                              |                   |               |                |                     |  |
|                                  | 025    |  | Allocate the signal to CN1-25.                  |              |                              |                   |               |                |                     |  |
|                                  | 027    |  | Allocate the signal to CN1-27.                  |              |                              |                   |               |                |                     |  |
|                                  | 029    |  | Allocate the signal to CN1-29.                  |              |                              |                   |               |                |                     |  |
|                                  | n.X□□□ |  | Polarity Selection                              |              |                              |                   |               |                |                     |  |
|                                  | 0      |  | Disabled (the above signal output is not used). |              |                              |                   |               |                |                     |  |
|                                  | 1      |  | Output the above signal.                        |              |                              |                   |               |                |                     |  |
| 2                                |        | Invert the above signal and output it.                 |   |              |                              |                   |               |                |                     |  |
| Pn5B6<br>(A: 25B6h,<br>B: 2DB6h) | 2      | /BK (Brake Output) Signal Allocation                   | 0000h to 2039h                                  | -            | Axis A: 1001h, Axis B: 1023h | All               | After restart | Setup          | page 6-31, page 7-3 |  |
|                                  | n.□XXX |  | Allocated Pin Number                            |              |                              |                   |               |                |                     |  |
|                                  | 001    |  | Allocate the signal to CN1-1.                   |              |                              |                   |               |                |                     |  |
|                                  | 023    |  | Allocate the signal to CN1-23.                  |              |                              |                   |               |                |                     |  |
|                                  | 025    |  | Allocate the signal to CN1-25.                  |              |                              |                   |               |                |                     |  |
|                                  | 027    |  | Allocate the signal to CN1-27.                  |              |                              |                   |               |                |                     |  |
|                                  | 029    |  | Allocate the signal to CN1-29.                  |              |                              |                   |               |                |                     |  |
|                                  | n.X□□□ |  | Polarity Selection                              |              |                              |                   |               |                |                     |  |
|                                  | 0      |  | Disabled (the above signal output is not used). |              |                              |                   |               |                |                     |  |
|                                  | 1      |  | Output the above signal.                        |              |                              |                   |               |                |                     |  |
| 2                                |        | Invert the above signal and output it.                 |   |              |                              |                   |               |                |                     |  |

Continued on next page.

Continued from previous page.

| Parameter No.                      | Size   | Name  | Setting Range                                   | Setting Unit | Default Setting | Applicable Motors | When Enabled  | Classification | Reference           |  |
|------------------------------------|--------|---|---|--------------|-----------------|-------------------|---------------|----------------|---------------------|--|
| Pn5B7<br>(A: 25B7h,<br>B: 2DB7h)   | 2      | /WARN (Warning Output) Signal Allocation                | 0000h to 2039h                                  | –            | 0000h           | All               | After restart | Setup          | page 7-3, page 7-10 |  |
|                                    | n.□XXX |   | Allocated Pin Number                            |              |                 |                   |               |                |                     |  |
|                                    | 001    |   | Allocate the signal to CN1-1.                   |              |                 |                   |               |                |                     |  |
|                                    | 023    |   | Allocate the signal to CN1-23.                  |              |                 |                   |               |                |                     |  |
|                                    | 025    |   | Allocate the signal to CN1-25.                  |              |                 |                   |               |                |                     |  |
|                                    | 027    |   | Allocate the signal to CN1-27.                  |              |                 |                   |               |                |                     |  |
|                                    | 029    |   | Allocate the signal to CN1-29.                  |              |                 |                   |               |                |                     |  |
|                                    | n.X□□□ |   | Polarity Selection                              |              |                 |                   |               |                |                     |  |
|                                    | 0      |   | Disabled (the above signal output is not used). |              |                 |                   |               |                |                     |  |
|                                    | 1      |   | Output the above signal.                        |              |                 |                   |               |                |                     |  |
|                                    | 2      |   | Invert the above signal and output it.          |              |                 |                   |               |                |                     |  |
| Pn5B8<br>(A: 25B8h,<br>B: 2DB8h)   | 2      | /NEAR (Near Output) Signal Allocation                   | 0000h to 2039h                                  | –            | 0000h           | All               | After restart | Setup          | page 7-3, page 7-15 |  |
|                                    | n.□XXX |   | Allocated Pin Number                            |              |                 |                   |               |                |                     |  |
|                                    | 001    |   | Allocate the signal to CN1-1.                   |              |                 |                   |               |                |                     |  |
|                                    | 023    |   | Allocate the signal to CN1-23.                  |              |                 |                   |               |                |                     |  |
|                                    | 025    |   | Allocate the signal to CN1-25.                  |              |                 |                   |               |                |                     |  |
|                                    | 027    |   | Allocate the signal to CN1-27.                  |              |                 |                   |               |                |                     |  |
|                                    | 029    |   | Allocate the signal to CN1-29.                  |              |                 |                   |               |                |                     |  |
|                                    | n.X□□□ |   | Polarity Selection                              |              |                 |                   |               |                |                     |  |
|                                    | 0      |   | Disabled (the above signal output is not used). |              |                 |                   |               |                |                     |  |
|                                    | 1      |   | Output the above signal.                        |              |                 |                   |               |                |                     |  |
|                                    | 2      |   | Invert the above signal and output it.          |              |                 |                   |               |                |                     |  |
| Pn5BC<br>(A: 25BCCh,<br>B: 2DBCCh) | 2      | /PM (Preventative Maintenance Output) Signal Allocation | 0000h to 2039h                                  | –            | 0000h           | All               | After restart | Setup          | page 10-15          |  |
|                                    | n.□XXX |   | Allocated Pin Number                            |              |                 |                   |               |                |                     |  |
|                                    | 001    |   | Allocate the signal to CN1-1.                   |              |                 |                   |               |                |                     |  |
|                                    | 023    |   | Allocate the signal to CN1-23.                  |              |                 |                   |               |                |                     |  |
|                                    | 025    |   | Allocate the signal to CN1-25.                  |              |                 |                   |               |                |                     |  |
|                                    | 027    |   | Allocate the signal to CN1-27.                  |              |                 |                   |               |                |                     |  |
|                                    | 029    |   | Allocate the signal to CN1-29.                  |              |                 |                   |               |                |                     |  |
|                                    | n.X□□□ |   | Polarity Selection                              |              |                 |                   |               |                |                     |  |
|                                    | 0      |   | Disabled (the above signal output is not used). |              |                 |                   |               |                |                     |  |
|                                    | 1      |   | Output the above signal.                        |              |                 |                   |               |                |                     |  |
|                                    | 2      |   | Invert the above signal and output it.          |              |                 |                   |               |                |                     |  |
| Pn600<br>(2600h)<br>Common         | 2      | Regenerative Resistor Capacity*2                        | Depends on model.*3                             | 10 W         | 0               | All               | Immediately   | Setup          | page 6-54           |  |
| Pn601<br>(A: 2601h,<br>B: 2E01h)   | 2      | Dynamic Brake Resistor Allowable Energy Consumption     | 0 to 65,535                                     | 10 J         | 0               | All               | After restart | Setup          | page 5-9            |  |

Continued on next page.

16.1 List of Servo Parameters

16.1.2 List of Parameters

Continued from previous page.

| Parameter No.                    | Size   | Name                                | Setting Range                  | Setting Unit  | Default Setting | Applicable Motors | When Enabled  | Classification | Reference |  |
|----------------------------------|--------|-------------------------------------|--------------------------------|---|-----------------|-------------------|---------------|----------------|-----------|--|
| Pn603<br>(2603h)<br>Common       | 2      | Regenerative Resistance             | 0 to 65,535                    | 10 mΩ   | 0               | All               | Immediately   | Setup          | page 6-54 |  |
| Pn604<br>(A: 2604h,<br>B: 2E04h) | 2      | Dynamic Brake Resistance            | 0 to 65,535                    | 10 mΩ   | 0               | All               | After restart | Setup          | page 5-9  |  |
| Pn61A<br>(A: 261Ah,<br>B: 2E1Ah) | 2      | Overheat Protection Selections      | 0000h to 0003h                 | -   | 0000h           | Linear            | After restart | Setup          | page 7-48 |  |
|                                  | n.□□□X |                                     | Overheat Protection Selections |   |                 |                   |               |                |           |  |
|                                  |        |                                     | 0                              | Disable overheat protection.  |                 |                   |               |                |           |  |
|                                  |        |                                     | 1                              | Use overheat protection in the Yaskawa Linear Servomotor.*6   |                 |                   |               |                |           |  |
|                                  |        |                                     | 2                              | Monitor a negative voltage input from a sensor attached to the machine and use overheat protection. |                 |                   |               |                |           |  |
|                                  |        |                                     | 3                              | Monitor a positive voltage input from a sensor attached to the machine and use overheat protection. |                 |                   |               |                |           |  |
| n.□□X□                           |        | Reserved parameter (Do not change.) |                                |   |                 |                   |               |                |           |  |
| n.□X□□                           |        | Reserved parameter (Do not change.) |                                |   |                 |                   |               |                |           |  |
| n.X□□□                           |        | Reserved parameter (Do not change.) |                                |   |                 |                   |               |                |           |  |
| Pn61B<br>*7<br>(261Bh)<br>Common | 2      | Overheat Alarm Level                | 0 to 500                       | 0.01 V  | 250             | All               | Immediately   | Setup          | page 7-50 |  |
| Pn61C<br>*7<br>(261Ch)<br>Common | 2      | Overheat Warning Level              | 0 to 100                       | 1%  | 100             | All               | Immediately   | Setup          | page 7-50 |  |
| Pn61D<br>*7<br>(261Dh)<br>Common | 2      | Overheat Alarm Filter Time          | 0 to 65,535                    | 1 s   | 0               | All               | Immediately   | Setup          | page 7-50 |  |

- \*1. Set a percentage of the motor rated torque.
- \*2. Normally set this parameter to 0. If you use an External Regenerative Resistor, set the capacity (W) of the External Regenerative Resistor.
- \*3. The upper limit is the maximum output capacity (W) of the SERVOPACK.
- \*4. With EtherCAT (CoE), this is automatically set when the power supply is turned ON.
- \*5. The default setting for axis A is 32 for a SERVOPACK with built-in Servomotor brake control.
- \*6. The SGLFW2 is the only Yaskawa Linear Servomotor that supports this function.
- \*7. Enabled only when Pn61A is set to n.□□□2 or n.□□□3.

# 16.2 Object List

| Index             | Subindex  | Name                                     | Data Type | Access | PDO Mapping | Saving to EEPROM*1 | Default Value | Lower Limit | Upper Limit | Unit      | Parameter No.*2 |
|-------------------|---|--|-----------|--------|-------------|--------------------|---------------|-------------|-------------|-----------|-----------------|
| 1000h<br>Common   | 0   | Device type                              | UDINT     | RO     | No          | No                 | 0x00020192    | -           | -           | -         | -               |
| 1001h<br>Common   | 0   | Error register                           | USINT     | RO     | No          | No                 | -             | -           | -           | -         | -               |
| 1008h<br>Common   | 0   | Manufacturer device name                 | STRING    | RO     | No          | No                 | -             | -           | -           | -         | -               |
| 100Ah<br>Common   | 0   | Manufacturer software version            | STRING    | RO     | No          | No                 | -             | -           | -           | -         | -               |
| 1010h<br>Common   | Store parameters                                |  |           |        |             |                    |               |             |             |           |                 |
|                   | 0   | Largest subindex supported               | USINT     | RO     | No          | No                 | 4             | -           | -           | -         | -               |
|                   | 1   | Save all parameters                      | UDINT     | RW     | No          | No                 | 0x00000001    | 0x00000000  | 0xFFFFFFFF  | -         | PnC00*3,4       |
|                   | 2   | Save communication parameters            | UDINT     | RW     | No          | No                 | 0x00000001    | 0x00000000  | 0xFFFFFFFF  | -         | PnC02*3,4       |
|                   | 3   | Save application parameters              | UDINT     | RW     | No          | No                 | 0x00000001    | 0x00000000  | 0xFFFFFFFF  | -         | PnC04*3,4       |
| 4                 | Save manufacturer defined parameters            | UDINT                                    | RW        | No     | No          | 0x00000001         | 0x00000000    | 0xFFFFFFFF  | -           | PnC06*3,4 |                 |
| 1011h<br>Common   | Restore default parameters                      |  |           |        |             |                    |               |             |             |           |                 |
|                   | 0   | Largest subindex supported               | USINT     | RO     | No          | No                 | 4             | -           | -           | -         | -               |
|                   | 1   | Restore all default parameters           | UDINT     | RW     | No          | No                 | 0x00000001    | 0x00000000  | 0xFFFFFFFF  | -         | PnC08*3,4       |
|                   | 2   | Restore communication default parameters | UDINT     | RW     | No          | No                 | 0x00000001    | 0x00000000  | 0xFFFFFFFF  | -         | PnC0A*3,4       |
|                   | 3   | Restore application default parameters   | UDINT     | RW     | No          | No                 | 0x00000001    | 0x00000000  | 0xFFFFFFFF  | -         | PnC0C*3,4       |
| 4                 | Restore manufacturer defined default parameters | UDINT                                    | RW        | No     | No          | 0x00000001         | 0x00000000    | 0xFFFFFFFF  | -           | PnC0E*3,4 |                 |
| 1018h<br>Common   | Identity object                                 |  |           |        |             |                    |               |             |             |           |                 |
|                   | 0   | Number of entries                        | USINT     | RO     | No          | No                 | 4             | -           | -           | -         | -               |
|                   | 1   | Vendor ID                                | UDINT     | RO     | No          | No                 | 0x539         | -           | -           | -         | -               |
|                   | 2   | Product code                             | UDINT     | RO     | No          | No                 | 0x02200402*5  | -           | -           | -         | -               |
|                   | 3   | Revision number                          | UDINT     | RO     | No          | No                 | -             | -           | -           | -         | -               |
| 4                 | Serial number                                   | UDINT                                    | RO        | No     | No          | 0                  | -             | -           | -           | -         |                 |
| 10F1h*6<br>Common | Sync error settings                             |  |           |        |             |                    |               |             |             |           |                 |
|                   | 0   | Number of entries                        | USINT     | RO     | No          | No                 | 2             | -           | -           | -         | -               |
|                   | 1   | Reserved                                 | UDINT     | RO     | No          | No                 | 0             | -           | -           | -         | -               |
| 2                 | Sync error counter limit                        | UINT                                     | RW        | No     | No          | 9                  | 0             | 15          | -           | PnCCC     |                 |
| 1600h<br>Axis A   | 1st receive PDO mapping                         |  |           |        |             |                    |               |             |             |           |                 |
|                   | 0   | Number of objects in this PDO            | USINT     | RW     | No          | Yes                | 8             | 0           | 8           | -         | PnCA0           |
|                   | 1   | Mapping entry 1                          | UDINT     | RW     | No          | Yes                | 0x60400010    | 0           | 0xFFFFFFFF  | -         | Pn800           |
|                   | 2   | Mapping entry 2                          | UDINT     | RW     | No          | Yes                | 0x607A0020    | 0           | 0xFFFFFFFF  | -         | Pn802           |
|                   | 3   | Mapping entry 3                          | UDINT     | RW     | No          | Yes                | 0x60FF0020    | 0           | 0xFFFFFFFF  | -         | Pn804           |
|                   | 4   | Mapping entry 4                          | UDINT     | RW     | No          | Yes                | 0x60710010    | 0           | 0xFFFFFFFF  | -         | Pn806           |
|                   | 5   | Mapping entry 5                          | UDINT     | RW     | No          | Yes                | 0x60720010    | 0           | 0xFFFFFFFF  | -         | Pn808           |
|                   | 6   | Mapping entry 6                          | UDINT     | RW     | No          | Yes                | 0x60600008    | 0           | 0xFFFFFFFF  | -         | Pn80A           |
|                   | 7   | Mapping entry 7                          | UDINT     | RW     | No          | Yes                | 0x00000008    | 0           | 0xFFFFFFFF  | -         | Pn80C           |
| 8                 | Mapping entry 8                                 | UDINT                                    | RW        | No     | Yes         | 0x60B80010         | 0             | 0xFFFFFFFF  | -           | Pn80E     |                 |

Continued on next page.

Continued from previous page.

| Index           | Sub-index               | Name                          | Data Type | Access | PDO Mapping | Saving to EEPROM <sup>*1</sup> | Default Value | Lower Limit | Upper Limit | Unit  | Parameter No. <sup>*2</sup> |
|-----------------|-------------------------|-------------------------------|-----------|--------|-------------|--------------------------------|---------------|-------------|-------------|-------|-----------------------------|
| 1601h<br>Axis A | 2nd receive PDO mapping |                               |           |        |             |                                |               |             |             |       |                             |
|                 | 0                       | Number of objects in this PDO | USINT     | RW     | No          | Yes                            | 2             | 0           | 8           | -     | PnCA1                       |
|                 | 1                       | Mapping entry 1               | UDINT     | RW     | No          | Yes                            | 0x60400010    | 0           | 0xFFFFFFFF  | -     | Pn810                       |
|                 | 2                       | Mapping entry 2               | UDINT     | RW     | No          | Yes                            | 0x607A0020    | 0           | 0xFFFFFFFF  | -     | Pn812                       |
|                 | 3                       | Mapping entry 3               | UDINT     | RW     | No          | Yes                            | 0             | 0           | 0xFFFFFFFF  | -     | Pn814                       |
|                 | 4                       | Mapping entry 4               | UDINT     | RW     | No          | Yes                            | 0             | 0           | 0xFFFFFFFF  | -     | Pn816                       |
|                 | 5                       | Mapping entry 5               | UDINT     | RW     | No          | Yes                            | 0             | 0           | 0xFFFFFFFF  | -     | Pn818                       |
|                 | 6                       | Mapping entry 6               | UDINT     | RW     | No          | Yes                            | 0             | 0           | 0xFFFFFFFF  | -     | Pn81A                       |
|                 | 7                       | Mapping entry 7               | UDINT     | RW     | No          | Yes                            | 0             | 0           | 0xFFFFFFFF  | -     | Pn81C                       |
| 8               | Mapping entry 8         | UDINT                         | RW        | No     | Yes         | 0                              | 0             | 0xFFFFFFFF  | -           | Pn81E |                             |
| 1602h<br>Axis A | 3rd receive PDO mapping |                               |           |        |             |                                |               |             |             |       |                             |
|                 | 0                       | Number of objects in this PDO | USINT     | RW     | No          | Yes                            | 2             | 0           | 8           | -     | PnCA2                       |
|                 | 1                       | Mapping entry 1               | UDINT     | RW     | No          | Yes                            | 0x60400010    | 0           | 0xFFFFFFFF  | -     | Pn820                       |
|                 | 2                       | Mapping entry 2               | UDINT     | RW     | No          | Yes                            | 0x60FF0020    | 0           | 0xFFFFFFFF  | -     | Pn822                       |
|                 | 3                       | Mapping entry 3               | UDINT     | RW     | No          | Yes                            | 0             | 0           | 0xFFFFFFFF  | -     | Pn824                       |
|                 | 4                       | Mapping entry 4               | UDINT     | RW     | No          | Yes                            | 0             | 0           | 0xFFFFFFFF  | -     | Pn826                       |
|                 | 5                       | Mapping entry 5               | UDINT     | RW     | No          | Yes                            | 0             | 0           | 0xFFFFFFFF  | -     | Pn828                       |
|                 | 6                       | Mapping entry 6               | UDINT     | RW     | No          | Yes                            | 0             | 0           | 0xFFFFFFFF  | -     | Pn82A                       |
|                 | 7                       | Mapping entry 7               | UDINT     | RW     | No          | Yes                            | 0             | 0           | 0xFFFFFFFF  | -     | Pn82C                       |
| 8               | Mapping entry 8         | UDINT                         | RW        | No     | Yes         | 0                              | 0             | 0xFFFFFFFF  | -           | Pn82E |                             |
| 1603h<br>Axis A | 4th receive PDO mapping |                               |           |        |             |                                |               |             |             |       |                             |
|                 | 0                       | Number of objects in this PDO | USINT     | RW     | No          | Yes                            | 2             | 0           | 8           | -     | PnCA3                       |
|                 | 1                       | Mapping entry 1               | UDINT     | RW     | No          | Yes                            | 0x60400010    | 0           | 0xFFFFFFFF  | -     | Pn830                       |
|                 | 2                       | Mapping entry 2               | UDINT     | RW     | No          | Yes                            | 0x60710010    | 0           | 0xFFFFFFFF  | -     | Pn832                       |
|                 | 3                       | Mapping entry 3               | UDINT     | RW     | No          | Yes                            | 0             | 0           | 0xFFFFFFFF  | -     | Pn834                       |
|                 | 4                       | Mapping entry 4               | UDINT     | RW     | No          | Yes                            | 0             | 0           | 0xFFFFFFFF  | -     | Pn836                       |
|                 | 5                       | Mapping entry 5               | UDINT     | RW     | No          | Yes                            | 0             | 0           | 0xFFFFFFFF  | -     | Pn838                       |
|                 | 6                       | Mapping entry 6               | UDINT     | RW     | No          | Yes                            | 0             | 0           | 0xFFFFFFFF  | -     | Pn83A                       |
|                 | 7                       | Mapping entry 7               | UDINT     | RW     | No          | Yes                            | 0             | 0           | 0xFFFFFFFF  | -     | Pn83C                       |
| 8               | Mapping entry 8         | UDINT                         | RW        | No     | Yes         | 0                              | 0             | 0xFFFFFFFF  | -           | Pn83E |                             |
| 1610h<br>Axis B | 1st receive PDO mapping |                               |           |        |             |                                |               |             |             |       |                             |
|                 | 0                       | Number of objects in this PDO | USINT     | RW     | No          | Yes                            | 8             | 0           | 8           | -     | PnCA8                       |
|                 | 1                       | Mapping entry 1               | UDINT     | RW     | No          | Yes                            | 0x68400010    | 0           | 0xFFFFFFFF  | -     | Pn840                       |
|                 | 2                       | Mapping entry 2               | UDINT     | RW     | No          | Yes                            | 0x687A0020    | 0           | 0xFFFFFFFF  | -     | Pn842                       |
|                 | 3                       | Mapping entry 3               | UDINT     | RW     | No          | Yes                            | 0x68FF0020    | 0           | 0xFFFFFFFF  | -     | Pn844                       |
|                 | 4                       | Mapping entry 4               | UDINT     | RW     | No          | Yes                            | 0x68710010    | 0           | 0xFFFFFFFF  | -     | Pn846                       |
|                 | 5                       | Mapping entry 5               | UDINT     | RW     | No          | Yes                            | 0x68720010    | 0           | 0xFFFFFFFF  | -     | Pn848                       |
|                 | 6                       | Mapping entry 6               | UDINT     | RW     | No          | Yes                            | 0x68600008    | 0           | 0xFFFFFFFF  | -     | Pn84A                       |
|                 | 7                       | Mapping entry 7               | UDINT     | RW     | No          | Yes                            | 0x00000008    | 0           | 0xFFFFFFFF  | -     | Pn84C                       |
| 8               | Mapping entry 8         | UDINT                         | RW        | No     | Yes         | 0x68B80010                     | 0             | 0xFFFFFFFF  | -           | Pn84E |                             |

Continued on next page.

Continued from previous page.

| Index           | Subindex                 | Name                          | Data Type | Access | PDO Mapping | Saving to EEPROM <sup>*1</sup> | Default Value | Lower Limit | Upper Limit | Unit  | Parameter No. <sup>*2</sup> |
|-----------------|--------------------------|-------------------------------|-----------|--------|-------------|--------------------------------|---------------|-------------|-------------|-------|-----------------------------|
| 1611h<br>Axis B | 2nd receive PDO mapping  |                               |           |        |             |                                |               |             |             |       |                             |
|                 | 0                        | Number of objects in this PDO | USINT     | RW     | No          | Yes                            | 2             | 0           | 8           | –     | PnCA9                       |
|                 | 1                        | Mapping entry 1               | UDINT     | RW     | No          | Yes                            | 0x68400010    | 0           | 0xFFFFFFFF  | –     | Pn850                       |
|                 | 2                        | Mapping entry 2               | UDINT     | RW     | No          | Yes                            | 0x687A0020    | 0           | 0xFFFFFFFF  | –     | Pn852                       |
|                 | 3                        | Mapping entry 3               | UDINT     | RW     | No          | Yes                            | 0             | 0           | 0xFFFFFFFF  | –     | Pn854                       |
|                 | 4                        | Mapping entry 4               | UDINT     | RW     | No          | Yes                            | 0             | 0           | 0xFFFFFFFF  | –     | Pn856                       |
|                 | 5                        | Mapping entry 5               | UDINT     | RW     | No          | Yes                            | 0             | 0           | 0xFFFFFFFF  | –     | Pn858                       |
|                 | 6                        | Mapping entry 6               | UDINT     | RW     | No          | Yes                            | 0             | 0           | 0xFFFFFFFF  | –     | Pn85A                       |
|                 | 7                        | Mapping entry 7               | UDINT     | RW     | No          | Yes                            | 0             | 0           | 0xFFFFFFFF  | –     | Pn85C                       |
| 8               | Mapping entry 8          | UDINT                         | RW        | No     | Yes         | 0                              | 0             | 0xFFFFFFFF  | –           | Pn85E |                             |
| 1612h<br>Axis B | 3rd receive PDO mapping  |                               |           |        |             |                                |               |             |             |       |                             |
|                 | 0                        | Number of objects in this PDO | USINT     | RW     | No          | Yes                            | 2             | 0           | 8           | –     | PnCAA                       |
|                 | 1                        | Mapping entry 1               | UDINT     | RW     | No          | Yes                            | 0x68400010    | 0           | 0xFFFFFFFF  | –     | Pn860                       |
|                 | 2                        | Mapping entry 2               | UDINT     | RW     | No          | Yes                            | 0x68FF0020    | 0           | 0xFFFFFFFF  | –     | Pn862                       |
|                 | 3                        | Mapping entry 3               | UDINT     | RW     | No          | Yes                            | 0             | 0           | 0xFFFFFFFF  | –     | Pn864                       |
|                 | 4                        | Mapping entry 4               | UDINT     | RW     | No          | Yes                            | 0             | 0           | 0xFFFFFFFF  | –     | Pn866                       |
|                 | 5                        | Mapping entry 5               | UDINT     | RW     | No          | Yes                            | 0             | 0           | 0xFFFFFFFF  | –     | Pn868                       |
|                 | 6                        | Mapping entry 6               | UDINT     | RW     | No          | Yes                            | 0             | 0           | 0xFFFFFFFF  | –     | Pn86A                       |
|                 | 7                        | Mapping entry 7               | UDINT     | RW     | No          | Yes                            | 0             | 0           | 0xFFFFFFFF  | –     | Pn86C                       |
| 8               | Mapping entry 8          | UDINT                         | RW        | No     | Yes         | 0                              | 0             | 0xFFFFFFFF  | –           | Pn86E |                             |
| 1613h<br>Axis B | 4th receive PDO mapping  |                               |           |        |             |                                |               |             |             |       |                             |
|                 | 0                        | Number of objects in this PDO | USINT     | RW     | No          | Yes                            | 2             | 0           | 8           | –     | PnCAB                       |
|                 | 1                        | Mapping entry 1               | UDINT     | RW     | No          | Yes                            | 0x68400010    | 0           | 0xFFFFFFFF  | –     | Pn870                       |
|                 | 2                        | Mapping entry 2               | UDINT     | RW     | No          | Yes                            | 0x68710010    | 0           | 0xFFFFFFFF  | –     | Pn872                       |
|                 | 3                        | Mapping entry 3               | UDINT     | RW     | No          | Yes                            | 0             | 0           | 0xFFFFFFFF  | –     | Pn874                       |
|                 | 4                        | Mapping entry 4               | UDINT     | RW     | No          | Yes                            | 0             | 0           | 0xFFFFFFFF  | –     | Pn876                       |
|                 | 5                        | Mapping entry 5               | UDINT     | RW     | No          | Yes                            | 0             | 0           | 0xFFFFFFFF  | –     | Pn878                       |
|                 | 6                        | Mapping entry 6               | UDINT     | RW     | No          | Yes                            | 0             | 0           | 0xFFFFFFFF  | –     | Pn87A                       |
|                 | 7                        | Mapping entry 7               | UDINT     | RW     | No          | Yes                            | 0             | 0           | 0xFFFFFFFF  | –     | Pn87C                       |
| 8               | Mapping entry 8          | UDINT                         | RW        | No     | Yes         | 0                              | 0             | 0xFFFFFFFF  | –           | Pn87E |                             |
| 1A00h<br>Axis A | 1st transmit PDO mapping |                               |           |        |             |                                |               |             |             |       |                             |
|                 | 0                        | Number of objects in this PDO | USINT     | RW     | No          | Yes                            | 8             | 0           | 8           | –     | PnCA4                       |
|                 | 1                        | Mapping entry 1               | UDINT     | RW     | No          | Yes                            | 0x60410010    | 0           | 0xFFFFFFFF  | –     | Pn900                       |
|                 | 2                        | Mapping entry 2               | UDINT     | RW     | No          | Yes                            | 0x60640020    | 0           | 0xFFFFFFFF  | –     | Pn902                       |
|                 | 3                        | Mapping entry 3               | UDINT     | RW     | No          | Yes                            | 0x60770010    | 0           | 0xFFFFFFFF  | –     | Pn904                       |
|                 | 4                        | Mapping entry 4               | UDINT     | RW     | No          | Yes                            | 0x60F40020    | 0           | 0xFFFFFFFF  | –     | Pn906                       |
|                 | 5                        | Mapping entry 5               | UDINT     | RW     | No          | Yes                            | 0x60610008    | 0           | 0xFFFFFFFF  | –     | Pn908                       |
|                 | 6                        | Mapping entry 6               | UDINT     | RW     | No          | Yes                            | 0x00000008    | 0           | 0xFFFFFFFF  | –     | Pn90A                       |
|                 | 7                        | Mapping entry 7               | UDINT     | RW     | No          | Yes                            | 0x60B90010    | 0           | 0xFFFFFFFF  | –     | Pn90C                       |
| 8               | Mapping entry 8          | UDINT                         | RW        | No     | Yes         | 0x60BA0020                     | 0             | 0xFFFFFFFF  | –           | Pn90E |                             |

Continued on next page.

Continued from previous page.

| Index           | Sub-index                | Name                          | Data Type | Access | PDO Mapping | Saving to EEPROM <sup>*1</sup> | Default Value | Lower Limit | Upper Limit | Unit  | Parameter No. <sup>*2</sup> |
|-----------------|--------------------------|-------------------------------|-----------|--------|-------------|--------------------------------|---------------|-------------|-------------|-------|-----------------------------|
| 1A01h<br>Axis A | 2nd transmit PDO mapping |                               |           |        |             |                                |               |             |             |       |                             |
|                 | 0                        | Number of objects in this PDO | USINT     | RW     | No          | Yes                            | 2             | 0           | 8           | -     | PnCA5                       |
|                 | 1                        | Mapping entry 1               | UDINT     | RW     | No          | Yes                            | 0x60410010    | 0           | 0xFFFFFFFF  | -     | Pn910                       |
|                 | 2                        | Mapping entry 2               | UDINT     | RW     | No          | Yes                            | 0x60640020    | 0           | 0xFFFFFFFF  | -     | Pn912                       |
|                 | 3                        | Mapping entry 3               | UDINT     | RW     | No          | Yes                            | 0             | 0           | 0xFFFFFFFF  | -     | Pn914                       |
|                 | 4                        | Mapping entry 4               | UDINT     | RW     | No          | Yes                            | 0             | 0           | 0xFFFFFFFF  | -     | Pn916                       |
|                 | 5                        | Mapping entry 5               | UDINT     | RW     | No          | Yes                            | 0             | 0           | 0xFFFFFFFF  | -     | Pn918                       |
|                 | 6                        | Mapping entry 6               | UDINT     | RW     | No          | Yes                            | 0             | 0           | 0xFFFFFFFF  | -     | Pn91A                       |
|                 | 7                        | Mapping entry 7               | UDINT     | RW     | No          | Yes                            | 0             | 0           | 0xFFFFFFFF  | -     | Pn91C                       |
| 8               | Mapping entry 8          | UDINT                         | RW        | No     | Yes         | 0                              | 0             | 0xFFFFFFFF  | -           | Pn91E |                             |
| 1A02h<br>Axis A | 3rd transmit PDO mapping |                               |           |        |             |                                |               |             |             |       |                             |
|                 | 0                        | Number of objects in this PDO | USINT     | RW     | No          | Yes                            | 2             | 0           | 8           | -     | PnCA6                       |
|                 | 1                        | Mapping entry 1               | UDINT     | RW     | No          | Yes                            | 0x60410010    | 0           | 0xFFFFFFFF  | -     | Pn920                       |
|                 | 2                        | Mapping entry 2               | UDINT     | RW     | No          | Yes                            | 0x60640020    | 0           | 0xFFFFFFFF  | -     | Pn922                       |
|                 | 3                        | Mapping entry 3               | UDINT     | RW     | No          | Yes                            | 0             | 0           | 0xFFFFFFFF  | -     | Pn924                       |
|                 | 4                        | Mapping entry 4               | UDINT     | RW     | No          | Yes                            | 0             | 0           | 0xFFFFFFFF  | -     | Pn926                       |
|                 | 5                        | Mapping entry 5               | UDINT     | RW     | No          | Yes                            | 0             | 0           | 0xFFFFFFFF  | -     | Pn928                       |
|                 | 6                        | Mapping entry 6               | UDINT     | RW     | No          | Yes                            | 0             | 0           | 0xFFFFFFFF  | -     | Pn92A                       |
|                 | 7                        | Mapping entry 7               | UDINT     | RW     | No          | Yes                            | 0             | 0           | 0xFFFFFFFF  | -     | Pn92C                       |
| 8               | Mapping entry 8          | UDINT                         | RW        | No     | Yes         | 0                              | 0             | 0xFFFFFFFF  | -           | Pn92E |                             |
| 1A03h<br>Axis A | 4th transmit PDO mapping |                               |           |        |             |                                |               |             |             |       |                             |
|                 | 0                        | Number of objects in this PDO | USINT     | RW     | No          | Yes                            | 3             | 0           | 8           | -     | PnCA7                       |
|                 | 1                        | Mapping entry 1               | UDINT     | RW     | No          | Yes                            | 0x60410010    | 0           | 0xFFFFFFFF  | -     | Pn930                       |
|                 | 2                        | Mapping entry 2               | UDINT     | RW     | No          | Yes                            | 0x60640020    | 0           | 0xFFFFFFFF  | -     | Pn932                       |
|                 | 3                        | Mapping entry 3               | UDINT     | RW     | No          | Yes                            | 0x60770010    | 0           | 0xFFFFFFFF  | -     | Pn934                       |
|                 | 4                        | Mapping entry 4               | UDINT     | RW     | No          | Yes                            | 0             | 0           | 0xFFFFFFFF  | -     | Pn936                       |
|                 | 5                        | Mapping entry 5               | UDINT     | RW     | No          | Yes                            | 0             | 0           | 0xFFFFFFFF  | -     | Pn938                       |
|                 | 6                        | Mapping entry 6               | UDINT     | RW     | No          | Yes                            | 0             | 0           | 0xFFFFFFFF  | -     | Pn93A                       |
|                 | 7                        | Mapping entry 7               | UDINT     | RW     | No          | Yes                            | 0             | 0           | 0xFFFFFFFF  | -     | Pn93C                       |
| 8               | Mapping entry 8          | UDINT                         | RW        | No     | Yes         | 0                              | 0             | 0xFFFFFFFF  | -           | Pn93E |                             |
| 1A10h<br>Axis B | 1st transmit PDO mapping |                               |           |        |             |                                |               |             |             |       |                             |
|                 | 0                        | Number of objects in this PDO | USINT     | RW     | No          | Yes                            | 8             | 0           | 8           | -     | PnCAC                       |
|                 | 1                        | Mapping entry 1               | UDINT     | RW     | No          | Yes                            | 0x68410010    | 0           | 0xFFFFFFFF  | -     | Pn940                       |
|                 | 2                        | Mapping entry 2               | UDINT     | RW     | No          | Yes                            | 0x68640020    | 0           | 0xFFFFFFFF  | -     | Pn942                       |
|                 | 3                        | Mapping entry 3               | UDINT     | RW     | No          | Yes                            | 0x68770010    | 0           | 0xFFFFFFFF  | -     | Pn944                       |
|                 | 4                        | Mapping entry 4               | UDINT     | RW     | No          | Yes                            | 0x68F40020    | 0           | 0xFFFFFFFF  | -     | Pn946                       |
|                 | 5                        | Mapping entry 5               | UDINT     | RW     | No          | Yes                            | 0x68610008    | 0           | 0xFFFFFFFF  | -     | Pn948                       |
|                 | 6                        | Mapping entry 6               | UDINT     | RW     | No          | Yes                            | 0x00000008    | 0           | 0xFFFFFFFF  | -     | Pn94A                       |
|                 | 7                        | Mapping entry 7               | UDINT     | RW     | No          | Yes                            | 0x68B90010    | 0           | 0xFFFFFFFF  | -     | Pn94C                       |
| 8               | Mapping entry 8          | UDINT                         | RW        | No     | Yes         | 0x68BA0020                     | 0             | 0xFFFFFFFF  | -           | Pn94E |                             |

Continued on next page.



Continued from previous page.

| Index           | Subindex                        | Name                                 | Data Type                     | Access | PDO Mapping | Saving to EEPROM <sup>*1</sup> | Default Value | Lower Limit | Upper Limit | Unit  | Parameter No. <sup>*2</sup> |
|-----------------|---------------------------------|--------------------------------------|-------------------------------|--------|-------------|--------------------------------|---------------|-------------|-------------|-------|-----------------------------|
| 1A11h<br>Axis B | 2nd transmit PDO mapping        |                                      |                               |        |             |                                |               |             |             |       |                             |
|                 | 0                               | Number of objects in this PDO        | USINT                         | RW     | No          | Yes                            | 2             | 0           | 8           | –     | PnCAD                       |
|                 | 1                               | Mapping entry 1                      | UDINT                         | RW     | No          | Yes                            | 0x68410010    | 0           | 0xFFFFFFFF  | –     | Pn950                       |
|                 | 2                               | Mapping entry 2                      | UDINT                         | RW     | No          | Yes                            | 0x68640020    | 0           | 0xFFFFFFFF  | –     | Pn952                       |
|                 | 3                               | Mapping entry 3                      | UDINT                         | RW     | No          | Yes                            | 0             | 0           | 0xFFFFFFFF  | –     | Pn954                       |
|                 | 4                               | Mapping entry 4                      | UDINT                         | RW     | No          | Yes                            | 0             | 0           | 0xFFFFFFFF  | –     | Pn956                       |
|                 | 5                               | Mapping entry 5                      | UDINT                         | RW     | No          | Yes                            | 0             | 0           | 0xFFFFFFFF  | –     | Pn958                       |
|                 | 6                               | Mapping entry 6                      | UDINT                         | RW     | No          | Yes                            | 0             | 0           | 0xFFFFFFFF  | –     | Pn95A                       |
|                 | 7                               | Mapping entry 7                      | UDINT                         | RW     | No          | Yes                            | 0             | 0           | 0xFFFFFFFF  | –     | Pn95C                       |
| 8               | Mapping entry 8                 | UDINT                                | RW                            | No     | Yes         | 0                              | 0             | 0xFFFFFFFF  | –           | Pn95E |                             |
| 1A12h<br>Axis B | 3rd transmit PDO mapping        |                                      |                               |        |             |                                |               |             |             |       |                             |
|                 | 0                               | Number of objects in this PDO        | USINT                         | RW     | No          | Yes                            | 2             | 0           | 8           | –     | PnCAE                       |
|                 | 1                               | Mapping entry 1                      | UDINT                         | RW     | No          | Yes                            | 0x68410010    | 0           | 0xFFFFFFFF  | –     | Pn960                       |
|                 | 2                               | Mapping entry 2                      | UDINT                         | RW     | No          | Yes                            | 0x68640020    | 0           | 0xFFFFFFFF  | –     | Pn962                       |
|                 | 3                               | Mapping entry 3                      | UDINT                         | RW     | No          | Yes                            | 0             | 0           | 0xFFFFFFFF  | –     | Pn964                       |
|                 | 4                               | Mapping entry 4                      | UDINT                         | RW     | No          | Yes                            | 0             | 0           | 0xFFFFFFFF  | –     | Pn966                       |
|                 | 5                               | Mapping entry 5                      | UDINT                         | RW     | No          | Yes                            | 0             | 0           | 0xFFFFFFFF  | –     | Pn968                       |
|                 | 6                               | Mapping entry 6                      | UDINT                         | RW     | No          | Yes                            | 0             | 0           | 0xFFFFFFFF  | –     | Pn96A                       |
|                 | 7                               | Mapping entry 7                      | UDINT                         | RW     | No          | Yes                            | 0             | 0           | 0xFFFFFFFF  | –     | Pn96C                       |
| 8               | Mapping entry 8                 | UDINT                                | RW                            | No     | Yes         | 0                              | 0             | 0xFFFFFFFF  | –           | Pn96E |                             |
| 1A13h<br>Axis B | 4th transmit PDO mapping        |                                      |                               |        |             |                                |               |             |             |       |                             |
|                 | 0                               | Number of objects in this PDO        | USINT                         | RW     | No          | Yes                            | 3             | 0           | 8           | –     | PnCAF                       |
|                 | 1                               | Mapping entry 1                      | UDINT                         | RW     | No          | Yes                            | 0x68410010    | 0           | 0xFFFFFFFF  | –     | Pn970                       |
|                 | 2                               | Mapping entry 2                      | UDINT                         | RW     | No          | Yes                            | 0x68640020    | 0           | 0xFFFFFFFF  | –     | Pn972                       |
|                 | 3                               | Mapping entry 3                      | UDINT                         | RW     | No          | Yes                            | 0x68770010    | 0           | 0xFFFFFFFF  | –     | Pn974                       |
|                 | 4                               | Mapping entry 4                      | UDINT                         | RW     | No          | Yes                            | 0             | 0           | 0xFFFFFFFF  | –     | Pn976                       |
|                 | 5                               | Mapping entry 5                      | UDINT                         | RW     | No          | Yes                            | 0             | 0           | 0xFFFFFFFF  | –     | Pn978                       |
|                 | 6                               | Mapping entry 6                      | UDINT                         | RW     | No          | Yes                            | 0             | 0           | 0xFFFFFFFF  | –     | Pn97A                       |
|                 | 7                               | Mapping entry 7                      | UDINT                         | RW     | No          | Yes                            | 0             | 0           | 0xFFFFFFFF  | –     | Pn97C                       |
| 8               | Mapping entry 8                 | UDINT                                | RW                            | No     | Yes         | 0                              | 0             | 0xFFFFFFFF  | –           | Pn97E |                             |
| 1C00h<br>Common | Sync Manager communication type |                                      |                               |        |             |                                |               |             |             |       |                             |
|                 | 0                               | Number of used Sync Manager channels | USINT                         | RO     | No          | No                             | 4             | –           | –           | –     | –                           |
|                 | 1                               | Communication type sync manager 0    | USINT                         | RO     | No          | No                             | 1             | –           | –           | –     | PnCB0 <sup>*4</sup>         |
|                 | 2                               | Communication type sync manager 1    | USINT                         | RO     | No          | No                             | 2             | –           | –           | –     | PnCB1 <sup>*4</sup>         |
|                 | 3                               | Communication type sync manager 2    | USINT                         | RO     | No          | No                             | 3             | –           | –           | –     | PnCB2 <sup>*4</sup>         |
| 1C10h<br>Common | 0                               | Sync Manager PDO assignment 0        | USINT                         | RO     | No          | No                             | 0             | –           | –           | –     | –                           |
|                 | 1C11h<br>Common                 | 0                                    | Sync Manager PDO assignment 1 | USINT  | RO          | No                             | No            | 0           | –           | –     | –                           |

Continued on next page.

Continued from previous page.

| Index           | Sub-index  | Name                                 | Data Type | Access | PDO Mapping | Saving to EEPROM <sup>*1</sup> | Default Value | Lower Limit | Upper Limit | Unit  | Parameter No. <sup>*2</sup> |
|-----------------|--|--------------------------------------|-----------|--------|-------------|--------------------------------|---------------|-------------|-------------|-------|-----------------------------|
| 1C12h<br>Common | Sync Manager PDO assignment 2                        |                                      |           |        |             |                                |               |             |             |       |                             |
|                 | 0  | Number of assigned PDOs              | USINT     | RW     | No          | Yes                            | 2             | 0           | 4           | -     | PnCBB                       |
|                 | 1  | Index of assigned RxPDO 1            | UINT      | RW     | No          | Yes                            | 0x1601        | 0x1600      | 0x1613      | -     | PnCB6                       |
|                 | 2  | Index of assigned RxPDO 2            | UINT      | RW     | No          | Yes                            | 0x1611        | 0x1600      | 0x1613      | -     | PnCB7                       |
|                 | 3  | Index of assigned RxPDO 3            | UINT      | RW     | No          | Yes                            | 0x1600        | 0x1600      | 0x1613      | -     | PnCB8                       |
| 4               | Index of assigned RxPDO 4                            | UINT                                 | RW        | No     | Yes         | 0x1610                         | 0x1600        | 0x1613      | -           | PnCB9 |                             |
| 1C13h<br>Common | Sync Manager PDO assignment 3                        |                                      |           |        |             |                                |               |             |             |       |                             |
|                 | 0  | Number of assigned PDOs              | USINT     | RW     | No          | Yes                            | 2             | 0           | 4           | -     | PnCBB                       |
|                 | 1  | Index of assigned TxPDO 1            | UINT      | RW     | No          | Yes                            | 0x1A01        | 0x1A00      | 0x1A13      | -     | PnCBC                       |
|                 | 2  | Index of assigned TxPDO 2            | UINT      | RW     | No          | Yes                            | 0x1A11        | 0x1A00      | 0x1A13      | -     | PnCBD                       |
|                 | 3  | Index of assigned TxPDO 3            | UINT      | RW     | No          | Yes                            | 0x1A00        | 0x1A00      | 0x1A13      | -     | PnCBE                       |
| 4               | Index of assigned TxPDO 4                            | UINT                                 | RW        | No     | Yes         | 0x1A10                         | 0x1A00        | 0x1A13      | -           | PnCBF |                             |
| 1C32h<br>Common | Sync Manager 2 (process data output) synchronization |                                      |           |        |             |                                |               |             |             |       |                             |
|                 | 0  | Number of synchronization parameters | USINT     | RO     | No          | No                             | 12            | -           | -           | -     | -                           |
|                 | 1  | Synchronization type                 | UINT      | RO     | No          | No                             | -             | -           | -           | -     | PnCC0 <sup>*4</sup>         |
|                 | 2  | Cycle time                           | UDINT     | RO     | No          | No                             | -             | -           | -           | -     | PnCC2 <sup>*4</sup>         |
|                 | 3  | Shift time                           | UDINT     | RO     | No          | No                             | 250000        | -           | -           | -     | PnCC4 <sup>*4</sup>         |
|                 | 4  | Synchronization types supported      | UINT      | RO     | No          | No                             | 0x0005        | -           | -           | -     | -                           |
|                 | 5  | Minimum cycle time                   | UDINT     | RO     | No          | No                             | 62500         | -           | -           | -     | -                           |
|                 | 6  | Calc and copy time                   | UDINT     | RO     | No          | No                             | 250000        | -           | -           | -     | -                           |
|                 | 7  | Reserved                             | UDINT     | RO     | No          | No                             | -             | -           | -           | -     | -                           |
|                 | 8  | Reserved                             | UINT      | RO     | No          | No                             | -             | -           | -           | -     | -                           |
|                 | 9  | Delay time                           | UDINT     | RO     | No          | No                             | 0             | -           | -           | -     | -                           |
|                 | 10   | Sync0 cycle time                     | UDINT     | RO     | No          | No                             | -             | -           | -           | -     | PnCC6 <sup>*4</sup>         |
|                 | 11   | SM event missed counter              | UINT      | RO     | No          | No                             | -             | -           | -           | -     | PnCC8 <sup>*4</sup>         |
| 12              | Reserved   | UINT                                 | RO        | No     | No          | -                              | -             | -           | -           | -     |                             |
| 1C33h<br>Common | Sync Manager 3 (process data input) synchronization  |                                      |           |        |             |                                |               |             |             |       |                             |
|                 | 0  | Number of synchronization parameters | USINT     | RO     | No          | No                             | 10            | -           | -           | -     | -                           |
|                 | 1  | Synchronization type                 | UINT      | RO     | No          | No                             | -             | -           | -           | -     | -                           |
|                 | 2  | Cycle time                           | UDINT     | RO     | No          | No                             | -             | -           | -           | -     | -                           |
|                 | 3  | Shift time                           | UDINT     | RW     | No          | Yes                            | 0             | 0           | 0xFFFFFFFF  | -     | PnCCA                       |
|                 | 4  | Synchronization types supported      | UINT      | RO     | No          | No                             | 0x0025        | -           | -           | -     | -                           |
|                 | 5  | Minimum cycle time                   | UDINT     | RO     | No          | No                             | 250000        | -           | -           | -     | -                           |
|                 | 6  | Calc and copy time                   | UDINT     | RO     | No          | No                             | 62500         | -           | -           | -     | -                           |
|                 | 7  | Reserved                             | UDINT     | RO     | No          | No                             | -             | -           | -           | -     | -                           |
|                 | 8  | Reserved                             | UINT      | RO     | No          | No                             | -             | -           | -           | -     | -                           |
|                 | 9  | Delay time                           | UDINT     | RO     | No          | No                             | 0             | -           | -           | -     | -                           |
|                 | 10   | Sync0 cycle time                     | UDINT     | RO     | No          | No                             | -             | -           | -           | -     | -                           |
|                 | 11   | SM event missed counter              | UINT      | RO     | No          | No                             | -             | -           | -           | -     | -                           |
| 12              | Reserved   | UINT                                 | RO        | No     | No          | -                              | -             | -           | -           | -     |                             |

Continued on next page.

Continued from previous page.

| Index                    | Sub-index  | Name                                | Data Type | Access | PDO Mapping | Saving to EEPROM <sup>*1</sup> | Default Value | Lower Limit | Upper Limit | Unit  | Parameter No. <sup>*2</sup>               |
|--------------------------|--|-------------------------------------|-----------|--------|-------------|--------------------------------|---------------|-------------|-------------|-------|---|
| 2000h to 26FFh<br>Axis A | 0  | SERVOPACK Parameter (Pn000 - Pn6FF) | -         | -      | -           | -                              | -             | -           | -           | -     | Pn000 <sup>*7</sup> - Pn6FF <sup>*7</sup> |
| 2700h<br>Axis A          | 0  | User parameter Configuration        | UDINT     | RW     | No          | No                             | 0             | 0           | 0xFFFFFFFF  | -     | PnB00                                     |
| 2701h<br>Axis A          | Position user unit                               |                                     |           |        |             |                                |               |             |             |       |   |
|                          | 0  | Number of entries                   | USINT     | RO     | No          | No                             | 2             | -           | -           | -     | -   |
|                          | 1  | Numerator                           | UDINT     | RW     | No          | Yes                            | 1             | 1           | 1073741823  | -     | PnB02                                     |
| 2702h<br>Axis A          | Velocity user unit                               |                                     |           |        |             |                                |               |             |             |       |   |
|                          | 0  | Number of entries                   | USINT     | RO     | No          | No                             | 2             | -           | -           | -     | -   |
|                          | 1  | Numerator                           | UDINT     | RW     | No          | Yes                            | 1             | 1           | 1073741823  | -     | PnB06                                     |
| 2703h<br>Axis A          | Acceleration user unit                           |                                     |           |        |             |                                |               |             |             |       |   |
|                          | 0  | Number of entries                   | USINT     | RO     | No          | No                             | 2             | -           | -           | -     | -   |
|                          | 1  | Numerator                           | UDINT     | RW     | No          | Yes                            | 1             | 1           | 1073741823  | -     | PnB0A                                     |
| 2704h<br>Axis A          | Torque user unit                                 |                                     |           |        |             |                                |               |             |             |       |   |
|                          | 0  | Number of entries                   | USINT     | RO     | No          | No                             | 2             | -           | -           | -     | -   |
|                          | 1  | Numerator                           | UDINT     | RW     | No          | Yes                            | 1             | 1           | 1073741823  | -     | PnB94                                     |
| 2705h<br>Axis A          | 0  | Encoder Selection                   | UINT      | RW     | No          | Yes                            | 0x0000        | 0x0000      | 0x0001      | -     | PnB9C                                     |
| 2710h<br>Axis A          | SERVOPACK adjusting command                      |                                     |           |        |             |                                |               |             |             |       |   |
|                          | 0  | Number of entries                   | USINT     | RO     | No          | No                             | 3             | -           | -           | -     | -   |
|                          | 1  | Command                             | STRING    | RW     | No          | No                             | 0             | 0           | 0xFF        | -     | -   |
|                          | 2  | Status                              | USINT     | RO     | No          | No                             | -             | -           | -           | -     | -   |
| 2730h<br>Axis A          | Interpolation data configuration for 1st profile |                                     |           |        |             |                                |               |             |             |       |   |
|                          | 0  | Number of entries                   | USINT     | RO     | No          | No                             | 9             | -           | -           | -     | -   |
|                          | 1  | Maximum buffer size                 | UDINT     | RO     | No          | No                             | 254           | -           | -           | -     | -   |
|                          | 2  | Actual buffer size                  | UDINT     | RW     | No          | No                             | 254           | -           | -           | -     | -   |
|                          | 3  | Buffer organization                 | USINT     | RW     | No          | No                             | 0             | 0           | 1           | -     | PnCEC                                     |
|                          | 4  | Buffer position                     | UINT      | RW     | Yes         | No                             | 1             | 1           | 254         | -     | PnCED                                     |
|                          | 5  | Size of data record                 | USINT     | WO     | No          | No                             | 1             | 1           | 1           | -     | -   |
|                          | 6  | Buffer clear                        | USINT     | WO     | No          | No                             | 0             | 0           | 1           | -     | -   |
|                          | 7  | Position data definition            | USINT     | RW     | Yes         | No                             | 1             | 0           | 1           | -     | PnCEE                                     |
|                          | 8  | Position data polarity              | USINT     | RW     | Yes         | No                             | 0             | 0           | 1           | -     | PnCEF                                     |
| 2731h<br>Axis A          | Interpolation data configuration for 2nd profile |                                     |           |        |             |                                |               |             |             |       |   |
|                          | 0  | Number of entries                   | USINT     | RO     | No          | No                             | 9             | -           | -           | -     | -   |
|                          | 1  | Maximum buffer size                 | UDINT     | RO     | No          | No                             | 254           | -           | -           | -     | -   |
|                          | 2  | Actual buffer size                  | UDINT     | RW     | No          | No                             | 254           | -           | -           | -     | -   |
|                          | 3  | Buffer organization                 | USINT     | RW     | No          | No                             | 0             | 0           | 1           | -     | PnCF1                                     |
|                          | 4  | Buffer position                     | UINT      | RW     | Yes         | No                             | 1             | 1           | 254         | -     | PnCF2                                     |
|                          | 5  | Size of data record                 | USINT     | WO     | No          | No                             | 1             | 1           | 1           | -     | -   |
|                          | 6  | Buffer clear                        | USINT     | WO     | No          | No                             | 0             | 0           | 1           | -     | -   |
|                          | 7  | Position data definition            | USINT     | RW     | Yes         | No                             | 1             | 0           | 1           | -     | PnCF3                                     |
|                          | 8  | Position data polarity              | USINT     | RW     | Yes         | No                             | 0             | 0           | 1           | -     | PnCF4                                     |
| 9                        | Behavior after reaching buffer position          | USINT                               | RW        | Yes    | No          | 0                              | 0             | 1           | -           | PnCF5 |   |

Continued on next page.

Continued from previous page.

| Index  | Sub-index | Name                                      | Data Type | Access | PDO Mapping | Saving to EEPROM <sup>*1</sup> | Default Value | Lower Limit | Upper Limit | Unit | Parameter No. <sup>*2</sup> |
|--|-----------|---|-----------|--------|-------------|--------------------------------|---------------|-------------|-------------|------|-----------------------------|
| 2732h<br>Axis A  | 0         | Interpolation profile select              | USINT     | RW     | Yes         | No                             | 0             | 0           | 1           | -    | PnCF6                       |
| Interpolation data read/write pointer position monitor |           |   |           |        |             |                                |               |             |             |      |                             |
| 2741h<br>Axis A  | 0         | Number of entries                         | USINT     | RO     | No          | No                             | 2             | -           | -           | -    | -                           |
|  | 1         | Interpolation data read pointer position  | UINT      | RO     | Yes         | No                             | -             | 1           | 254         | -    | PnCF7 <sup>*4</sup>         |
|  | 2         | Interpolation data write pointer position | UINT      | RO     | Yes         | No                             | -             | 1           | 254         | -    | PnCF8 <sup>*4</sup>         |
| Interpolation data record for 1st profile              |           |   |           |        |             |                                |               |             |             |      |                             |
| 27C0h<br>Axis A  | 0         | Number of entries                         | USINT     | RO     | No          | No                             | 254           | -           | -           | -    | -                           |
|  | 1 to 254  | 1st set-point to 254 set-point            | DINT      | RW     | No          | No                             | 0             | -2147483648 | 2147483647  | -    | -                           |
| Interpolation data record for 2nd profile              |           |   |           |        |             |                                |               |             |             |      |                             |
| 27C1h<br>Axis A  | 0         | Number of entries                         | USINT     | RO     | No          | No                             | 254           | -           | -           | -    | -                           |
|  | 1 to 254  | 1st set-point to 254 set-point            | DINT      | RW     | No          | No                             | 0             | -2147483648 | 2147483647  | -    | -                           |
| 27E0h<br>Axis A  | -         | Diag. mode                                | UINT      | RW     | No          | No                             | 0             | 0           | 0xFFFF      | -    | PnCFE                       |
| 2800h to 2EFFh<br>Axis B                               | 0         | SERVOPACK Parameter (Pn000 - Pn6FF)       | -         | -      | -           | -                              | -             | -           | -           | -    | Pn000 - Pn6FF               |
| 2F00h<br>Axis B  | 0         | User parameter Configuration              | UDINT     | RW     | No          | No                             | 0             | 0           | 0xFFFFFFFF  | -    | PnB00                       |
| Position user unit                                     |           |   |           |        |             |                                |               |             |             |      |                             |
| 2F01h<br>Axis B  | 0         | Number of entries                         | USINT     | RO     | No          | No                             | 2             | -           | -           | -    | -                           |
|  | 1         | Numerator                                 | UDINT     | RW     | No          | Yes                            | 1             | 1           | 1073741823  | -    | PnB02                       |
|  | 2         | Denominator                               | UDINT     | RW     | No          | Yes                            | 1             | 1           | 1073741823  | -    | PnB04                       |
| Velocity user unit                                     |           |   |           |        |             |                                |               |             |             |      |                             |
| 2F02h<br>Axis B  | 0         | Number of entries                         | USINT     | RO     | No          | No                             | 2             | -           | -           | -    | -                           |
|  | 1         | Numerator                                 | UDINT     | RW     | No          | Yes                            | 1             | 1           | 1073741823  | -    | PnB06                       |
|  | 2         | Denominator                               | UDINT     | RW     | No          | Yes                            | 1             | 1           | 1073741823  | -    | PnB08                       |
| Acceleration user unit                                 |           |   |           |        |             |                                |               |             |             |      |                             |
| 2F03h<br>Axis B  | 0         | Number of entries                         | USINT     | RO     | No          | No                             | 2             | -           | -           | -    | -                           |
|  | 1         | Numerator                                 | UDINT     | RW     | No          | Yes                            | 1             | 1           | 1073741823  | -    | PnB0A                       |
|  | 2         | Denominator                               | UDINT     | RW     | No          | Yes                            | 1             | 1           | 1073741823  | -    | PnB0C                       |
| Torque user unit                                       |           |   |           |        |             |                                |               |             |             |      |                             |
| 2F04h<br>Axis B  | 0         | Number of entries                         | USINT     | RO     | No          | No                             | 2             | -           | -           | -    | -                           |
|  | 1         | Numerator                                 | UDINT     | RW     | No          | Yes                            | 1             | 1           | 1073741823  | -    | PnB94                       |
|  | 2         | Denominator                               | UDINT     | RW     | No          | Yes                            | 10            | 1           | 1073741823  | -    | PnB96                       |
| 2F05h<br>Axis B  | 0         | Encoder Selection                         | UINT      | RW     | No          | Yes                            | 0x0000        | 0x0000      | 0x0001      | -    | PnB9C                       |
| SERVOPACK adjusting command                            |           |   |           |        |             |                                |               |             |             |      |                             |
| 2F10h<br>Axis B  | 0         | Number of entries                         | USINT     | RO     | No          | No                             | 3             | -           | -           | -    | -                           |
|  | 1         | Command                                   | STRING    | RW     | No          | No                             | 0             | 0           | 0xFF        | -    | -                           |
|  | 2         | Status                                    | USINT     | RO     | No          | No                             | -             | -           | -           | -    | -                           |
|  | 3         | Reply                                     | STRING    | RO     | No          | No                             | -             | -           | -           | -    | -                           |

Continued on next page.

Continued from previous page.

| Index           | Sub-index  | Name                                     | Data Type | Access | PDO Mapping | Saving to EEPROM <sup>*1</sup> | Default Value | Lower Limit | Upper Limit | Unit  | Parameter No. <sup>*2</sup> |
|-----------------|--|--|-----------|--------|-------------|--------------------------------|---------------|-------------|-------------|-------|-----------------------------|
| 2F30h<br>Axis B | Interpolation data configuration for 1st profile       |  |           |        |             |                                |               |             |             |       |                             |
|                 | 0  | Number of entries                        | USINT     | RO     | No          | No                             | 9             | –           | –           | –     | –                           |
|                 | 1  | Maximum buffer size                      | UDINT     | RO     | No          | No                             | 254           | –           | –           | –     | –                           |
|                 | 2  | Actual buffer size                       | UDINT     | RW     | No          | No                             | 254           | –           | –           | –     | –                           |
|                 | 3  | Buffer organization                      | USINT     | RW     | No          | No                             | 0             | 0           | 1           | –     | PnCEC                       |
|                 | 4  | Buffer position                          | UINT      | RW     | Yes         | No                             | 1             | 1           | 254         | –     | PnCED                       |
|                 | 5  | Size of data record                      | USINT     | WO     | No          | No                             | 1             | 1           | 1           | –     | –                           |
|                 | 6  | Buffer clear                             | USINT     | WO     | No          | No                             | 0             | 0           | 1           | –     | –                           |
|                 | 7  | Position data definition                 | USINT     | RW     | Yes         | No                             | 1             | 0           | 1           | –     | PnCEE                       |
| 8               | Position data polarity                                 | USINT                                    | RW        | Yes    | No          | 0                              | 0             | 1           | –           | PnCEF |                             |
| 9               | Behavior after reaching buffer position                | USINT                                    | RW        | Yes    | No          | 0                              | 0             | 1           | –           | PnCF0 |                             |
| 2F31h<br>Axis B | Interpolation data configuration for 2nd profile       |  |           |        |             |                                |               |             |             |       |                             |
|                 | 0  | Number of entries                        | USINT     | RO     | No          | No                             | 9             | –           | –           | –     | –                           |
|                 | 1  | Maximum buffer size                      | UDINT     | RO     | No          | No                             | 254           | –           | –           | –     | –                           |
|                 | 2  | Actual buffer size                       | UDINT     | RW     | No          | No                             | 254           | –           | –           | –     | –                           |
|                 | 3  | Buffer organization                      | USINT     | RW     | No          | No                             | 0             | 0           | 1           | –     | PnCF1                       |
|                 | 4  | Buffer position                          | UINT      | RW     | Yes         | No                             | 1             | 1           | 254         | –     | PnCF2                       |
|                 | 5  | Size of data record                      | USINT     | WO     | No          | No                             | 1             | 1           | 1           | –     | –                           |
|                 | 6  | Buffer clear                             | USINT     | WO     | No          | No                             | 0             | 0           | 1           | –     | –                           |
|                 | 7  | Position data definition                 | USINT     | RW     | Yes         | No                             | 1             | 0           | 1           | –     | PnCF3                       |
| 8               | Position data polarity                                 | USINT                                    | RW        | Yes    | No          | 0                              | 0             | 1           | –           | PnCF4 |                             |
| 9               | Behavior after reaching buffer position                | USINT                                    | RW        | Yes    | No          | 0                              | 0             | 1           | –           | PnCF5 |                             |
| 2F32h<br>Axis B | 0  | Interpolation profile select             | USINT     | RW     | Yes         | No                             | 0             | 0           | 1           | –     | PnCF6                       |
| 2F41h<br>Axis B | Interpolation data read/write pointer position monitor |  |           |        |             |                                |               |             |             |       |                             |
|                 | 0  | Number of entries                        | UINT      | RO     | No          | No                             | 2             | –           | –           | –     | –                           |
|                 | 1  | Interpolation data read pointer position | UINT      | RO     | Yes         | No                             | –             | 1           | 254         | –     | PnCF7                       |
| 2               | Interpolation data write pointer position              | UINT                                     | RO        | Yes    | No          | –                              | 1             | 254         | –           | PnCF8 |                             |
| 2FC0h<br>Axis B | Interpolation data record for 1st profile              |  |           |        |             |                                |               |             |             |       |                             |
|                 | 0  | Number of entries                        | USINT     | RO     | No          | No                             | 9             | –           | –           | –     | –                           |
| 1 to 254        | 1st set-point to 254 set-point                         | DINT                                     | RW        | No     | No          | 254                            | -2147483648   | 2147483647  | –           | –     |                             |
| 2FC1h<br>Axis B | Interpolation data record for 2nd profile              |  |           |        |             |                                |               |             |             |       |                             |
|                 | 0  | Number of entries                        | USINT     | RO     | No          | No                             | 9             | –           | –           | –     | –                           |
| 1 to 254        | 1st set-point to 254 set-point                         | DINT                                     | RW        | No     | No          | 254                            | -2147483648   | 2147483647  | –           | –     |                             |
| 2FE0h<br>Axis B | –  | Diag. mode                               | UINT      | RW     | No          | No                             | 0             | 0           | 0xFFFF      | –     | PnCFE                       |
| 603Fh<br>Axis A | 0  | Error code                               | UINT      | RO     | Yes         | No                             | –             | –           | –           | –     | PnB10 <sup>*4</sup>         |
| 6040h<br>Axis A | 0  | Control word                             | UINT      | RW     | Yes         | No                             | 0             | 0           | 0xFFFF      | –     | PnB11                       |
| 6041h<br>Axis A | 0  | Status word                              | UINT      | RO     | Yes         | No                             | –             | –           | –           | –     | PnB12 <sup>*4</sup>         |
| 605Ah<br>Axis A | 0  | Quick stop option code                   | INT       | RW     | No          | Yes                            | 2             | 0           | 4           | –     | PnB13                       |
| 605Bh<br>Axis A | 0  | Shutdown option code                     | INT       | RW     | No          | Yes                            | 0             | 0           | 1           | –     | PnB14                       |
| 605Ch<br>Axis A | 0  | Disable operation option code            | INT       | RW     | No          | Yes                            | 1             | 0           | 1           | –     | PnB15                       |

Continued on next page.

Continued from previous page.

| Index           | Sub-index               | Name                           | Data Type | Access | PDO Mapping | Saving to EEPROM <sup>1</sup> | Default Value    | Lower Limit | Upper Limit | Unit      | Parameter No. <sup>2</sup> |
|-----------------|-------------------------|--------------------------------|-----------|--------|-------------|-------------------------------|------------------|-------------|-------------|-----------|----------------------------|
| 605Dh<br>Axis A | 0                       | Halt option code               | INT       | RW     | No          | Yes                           | 1                | 0           | 4           | –         | PnB16                      |
| 605Eh<br>Axis A | 0                       | Fault reaction option code     | INT       | RW     | No          | Yes                           | 0                | 0           | 0           | –         | PnB17                      |
| 6060h<br>Axis A | 0                       | Modes of operation             | SINT      | RW     | Yes         | Yes                           | 0                | 0           | 10          | –         | PnB18                      |
| 6061h<br>Axis A | 0                       | Modes of operation display     | SINT      | RO     | Yes         | No                            | 0                | –           | –           | –         | PnB19 <sup>4</sup>         |
| 6062h<br>Axis A | 0                       | Position demand value          | DINT      | RO     | Yes         | No                            | –                | –           | –           | Pos. unit | PnB20 <sup>4</sup>         |
| 6063h<br>Axis A | 0                       | Position actual internal value | DINT      | RO     | Yes         | No                            | –                | –           | –           | Inc       | PnB22 <sup>4</sup>         |
| 6064h<br>Axis A | 0                       | Position actual value          | DINT      | RO     | Yes         | No                            | –                | –           | –           | Pos. unit | PnB24 <sup>4</sup>         |
| 6065h<br>Axis A | 0                       | Following error window         | UDINT     | RW     | No          | Yes                           | 5242880          | 0           | 1073741823  | Pos. unit | PnB26                      |
| 6066h<br>Axis A | 0                       | Following error time out       | UINT      | RW     | No          | Yes                           | 0                | 0           | 65535       | ms        | PnB28                      |
| 6067h<br>Axis A | 0                       | Position window                | UDINT     | RW     | No          | Yes                           | 30               | 0           | 1073741823  | Pos. unit | PnB2A                      |
| 6068h<br>Axis A | 0                       | Position window time           | UINT      | RW     | No          | Yes                           | 0                | 0           | 65535       | ms        | PnB2C                      |
| 606Bh<br>Axis A | 0                       | Velocity demand value          | DINT      | RO     | Yes         | No                            | –                | –           | –           | Vel. Unit | PnB2E <sup>4</sup>         |
| 606Ch<br>Axis A | 0                       | Velocity actual value          | DINT      | RO     | Yes         | No                            | –                | –           | –           | Vel. Unit | PnB30 <sup>4</sup>         |
| 606Dh<br>Axis A | 0                       | Velocity window                | UINT      | RW     | No          | Yes                           | 20000            | 0           | 65535       | Vel. Unit | PnB32                      |
| 606Eh<br>Axis A | 0                       | Velocity window time           | UINT      | RW     | No          | Yes                           | 0                | 0           | 65535       | ms        | PnB34                      |
| 6071h<br>Axis A | 0                       | Target torque                  | INT       | RW     | Yes         | No                            | 0                | –32768      | 32767       | 0.1 %     | PnB36                      |
| 6072h<br>Axis A | 0                       | Max torque                     | UINT      | RW     | Yes         | No                            | Motor max torque | 0           | 65535       | 0.1 %     | PnB38                      |
| 6074h<br>Axis A | 0                       | Max current                    | INT       | RO     | Yes         | No                            | –                | –           | –           | 0.1 %     | PnB3A <sup>4</sup>         |
| 6076h<br>Axis A | 0                       | Motor rated torque             | UDINT     | RO     | No          | No                            | –                | –           | –           | mNm, mN   | PnB3C <sup>4</sup>         |
| 6077h<br>Axis A | 0                       | Torque actual value            | INT       | RO     | Yes         | No                            | –                | –           | –           | 0.1 %     | PnB3E <sup>4</sup>         |
| 607Ah<br>Axis A | 0                       | Target position                | DINT      | RW     | Yes         | No                            | 0                | –2147483648 | 2147483647  | Pos. unit | PnB40                      |
| 607Ch<br>Axis A | –                       | Home offset                    | DINT      | RW     | No          | Yes                           | 0                | –536870912  | 536870911   | Pos. unit | PnB46                      |
| 607Dh<br>Axis A | Software position limit |                                |           |        |             |                               |                  |             |             |           |                            |
|                 | 0                       | Number of entries              | USINT     | RO     | No          | No                            | 2                | –           | –           | –         | –                          |
|                 | 1                       | Min position limit             | DINT      | RW     | No          | Yes                           | 0                | –536870912  | 536870911   | Pos. unit | PnB48                      |
|                 | 2                       | Max position limit             | DINT      | RW     | No          | Yes                           | 0                | –536870912  | 536870911   | Pos. unit | PnB4A                      |
| 607Fh<br>Axis A | 0                       | Max profile velocity           | UDINT     | RW     | Yes         | Yes                           | 2147483647       | 0           | 4294967295  | Vel. Unit | PnB4C                      |
| 6081h<br>Axis A | 0                       | Profile velocity               | UDINT     | RW     | Yes         | Yes                           | 0                | 0           | 4294967295  | Vel. Unit | PnB4E                      |
| 6083h<br>Axis A | 0                       | Profile acceleration           | UDINT     | RW     | Yes         | Yes                           | 1000             | 0           | 4294967295  | Acc. Unit | PnB50                      |
| 6084h<br>Axis A | 0                       | Profile deceleration           | UDINT     | RW     | Yes         | Yes                           | 1000             | 0           | 4294967295  | Acc. Unit | PnB52                      |

Continued on next page.

Continued from previous page.

| Index           | Sub-index                        | Name                             | Data Type | Access | PDO Mapping | Saving to EEPROM <sup>*1</sup> | Default Value | Lower Limit | Upper Limit | Unit      | Parameter No. <sup>*2</sup> |
|-----------------|----------------------------------|----------------------------------|-----------|--------|-------------|--------------------------------|---------------|-------------|-------------|-----------|-----------------------------|
| 6085h<br>Axis A | 0                                | Quick stop deceleration          | UDINT     | RW     | Yes         | Yes                            | 1000          | 0           | 4294967295  | Acc. Unit | PnB54                       |
| 6086h<br>Axis A | 0                                | Motion profile type              | INT       | RW     | Yes         | Yes                            | 0             | -32768      | 32767       | -         | PnB98                       |
| 6087h<br>Axis A | 0                                | Torque slope                     | UDINT     | RW     | Yes         | Yes                            | 1000          | 0           | 4294967295  | 0.1 %/s   | PnB56                       |
| 6098h<br>Axis A | 0                                | Homing method                    | SINT      | RW     | Yes         | No                             | 35            | 0           | 35          | -         | PnB58                       |
| 6099h<br>Axis A | Homing speeds                    |                                  |           |        |             |                                |               |             |             |           |                             |
|                 | 0                                | Number of entries                | USINT     | RO     | No          | No                             | 2             | -           | -           | -         | -                           |
|                 | 1                                | Speed during search for switch   | UDINT     | RW     | Yes         | Yes                            | 500000        | 0           | 4294967295  | Vel. Unit | PnB5A                       |
|                 | 2                                | Speed during search for zero     | UDINT     | RW     | Yes         | Yes                            | 100000        | 0           | 4294967295  | Vel. Unit | PnB5C                       |
| 609Ah<br>Axis A | 0                                | Homing acceleration              | UDINT     | RW     | Yes         | Yes                            | 1000          | 0           | 4294967295  | Acc. Unit | PnB5E                       |
| 60A4h<br>Axis A | Profile jerk                     |                                  |           |        |             |                                |               |             |             |           |                             |
|                 | 0                                | Number of entries                | USINT     | RO     | No          | No                             | 1             | -           | -           | -         | -                           |
|                 | 1                                | Profile jerk1                    | UDINT     | RW     | No          | Yes                            | 25            | 0           | 50          | %         | PnB9A                       |
| 60B1h<br>Axis A | 0                                | Velocity offset                  | DINT      | RW     | Yes         | No                             | 0             | -2147483648 | 2147483647  | Vel. Unit | PnB60                       |
| 60B2h<br>Axis A | 0                                | Torque offset                    | INT       | RW     | Yes         | No                             | 0             | -32768      | 32767       | 0.1 %     | PnB62                       |
| 60B8h<br>Axis A | 0                                | Touch probe function             | UINT      | RW     | Yes         | No                             | 0             | 0           | 0xFFFF      | -         | PnB64                       |
| 60B9h<br>Axis A | 0                                | Touch probe status               | UINT      | RO     | Yes         | No                             | -             | -           | -           | -         | PnB66                       |
| 60BAh<br>Axis A | 0                                | Touch probe pos1 pos value       | DINT      | RO     | Yes         | No                             | -             | -           | -           | Pos. unit | PnB68                       |
| 60BCh<br>Axis A | 0                                | Touch probe pos2 pos value       | DINT      | RO     | Yes         | No                             | -             | -           | -           | Pos. unit | PnB6A                       |
| 60C0h<br>Axis A | 0                                | Interpolation sub mode select    | INT       | RW     | No          | No                             | 0             | -3          | 0           | -         | PnB92                       |
| 60C1h<br>Axis A | Interpolation data record        |                                  |           |        |             |                                |               |             |             |           |                             |
|                 | 0                                | Number of entries                | USINT     | RO     | No          | No                             | 1             | -           | -           | -         | -                           |
|                 | 1                                | Interpolation data record        | DINT      | RW     | Yes         | No                             | 0             | -2147483648 | 2147483647  | Pos. unit | PnB70                       |
| 60C2h<br>Axis A | Interpolation time period        |                                  |           |        |             |                                |               |             |             |           |                             |
|                 | 0                                | Number of entries                | USINT     | RO     | No          | No                             | 2             | -           | -           | -         | -                           |
|                 | 1                                | Interpolation time period value  | USINT     | RW     | No          | No                             | 125           | 1           | 250         | -         | PnB6E                       |
|                 | 2                                | Interpolation time index         | SINT      | RW     | No          | No                             | -6            | -6          | -3          | -         | PnB6F                       |
| 60E0h<br>Axis A | 0                                | Positive torque limit value      | UINT      | RW     | Yes         | Yes                            | 8000          | 0           | 65535       | 0.1 %     | PnB80                       |
| 60E1h<br>Axis A | 0                                | Negative torque limit value      | UINT      | RW     | Yes         | Yes                            | 8000          | 0           | 65535       | 0.1 %     | PnB82                       |
| 60E4h<br>Axis A | Additional position actual value |                                  |           |        |             |                                |               |             |             |           |                             |
|                 | 0                                | Number of entries                | UINT      | RO     | No          | No                             | 1             | -           | -           | -         | -                           |
|                 | 1                                | Additional Position Actual Value | UINT      | RO     | Yes         | No                             | 0             | -           | -           | -         | -                           |
| 60F4h<br>Axis A | 0                                | Following error actual value     | DINT      | RO     | Yes         | No                             | -             | -           | -           | Pos. unit | PnB84                       |
| 60FCh<br>Axis A | 0                                | Position demand internal value   | DINT      | RO     | Yes         | No                             | -             | -           | -           | Inc       | PnB86                       |
| 60FDh<br>Axis A | 0                                | Digital inputs                   | UDINT     | RO     | Yes         | No                             | -             | -           | -           | -         | PnB88                       |

Continued on next page.

Continued from previous page.

| Index           | Sub-index       | Name                           | Data Type | Access | PDO Mapping | Saving to EEPROM <sup>*1</sup> | Default Value    | Lower Limit | Upper Limit | Unit      | Parameter No. <sup>*2</sup> |
|-----------------|-----------------|--------------------------------|-----------|--------|-------------|--------------------------------|------------------|-------------|-------------|-----------|-----------------------------|
| 60FEh<br>Axis A | Digital outputs |                                |           |        |             |                                |                  |             |             |           |                             |
|                 | 0               | Number of entries              | USINT     | RO     | No          | No                             | 2                | -           | -           | -         | -                           |
|                 | 1               | Physical outputs               | UDINT     | RW     | Yes         | No                             | 0                | 0           | 0xFFFFFFFF  | -         | PnB8A                       |
|                 | 2               | Bit mask                       | UDINT     | RW     | No          | Yes                            | 0x000C0000       | 0           | 0xFFFFFFFF  | -         | PnB8C                       |
| 60FFh<br>Axis A | 0               | Target velocity                | DINT      | RW     | Yes         | No                             | 0                | -2147483648 | 2147483647  | Vel. Unit | PnB8E                       |
| 6502h<br>Axis A | 0               | Supported drive modes          | UDINT     | RO     | No          | No                             | 0x03ED           | -           | -           | -         | PnB90                       |
| 683Fh<br>Axis B | 0               | Error code                     | UINT      | RO     | Yes         | No                             | -                | -           | -           | -         | PnB10                       |
| 6840h<br>Axis B | 0               | Control word                   | UINT      | RW     | Yes         | No                             | 0                | 0           | 0xFFFF      | -         | PnB11                       |
| 6841h<br>Axis B | 0               | Status word                    | UINT      | RO     | Yes         | No                             | -                | -           | -           | -         | PnB12                       |
| 685Ah<br>Axis B | 0               | Quick stop option code         | INT       | RW     | No          | Yes                            | 2                | 0           | 4           | -         | PnB13                       |
| 685Bh<br>Axis B | 0               | Shutdown option code           | INT       | RW     | No          | Yes                            | 0                | 0           | 1           | -         | PnB14                       |
| 685Ch<br>Axis B | 0               | Disable operation option code  | INT       | RW     | No          | Yes                            | 1                | 0           | 1           | -         | PnB15                       |
| 685Dh<br>Axis B | 0               | Halt option code               | INT       | RW     | No          | Yes                            | 1                | 0           | 4           | -         | PnB16                       |
| 685Eh<br>Axis B | 0               | Fault reaction option code     | INT       | RW     | No          | Yes                            | 0                | 0           | 0           | -         | PnB17                       |
| 6860h<br>Axis B | 0               | Modes of operation             | SINT      | RW     | Yes         | Yes                            | 0                | 0           | 10          | -         | PnB18                       |
| 6861h<br>Axis B | 0               | Modes of operation display     | SINT      | RO     | Yes         | No                             | 0                | -           | -           | -         | PnB19                       |
| 6862h<br>Axis B | 0               | Position demand value          | DINT      | RO     | Yes         | No                             | -                | -           | -           | Pos. unit | PnB20                       |
| 6863h<br>Axis B | 0               | Position actual internal value | DINT      | RO     | Yes         | No                             | -                | -           | -           | Inc       | PnB22                       |
| 6864h<br>Axis B | 0               | Position actual value          | DINT      | RO     | Yes         | No                             | -                | -           | -           | Pos. unit | PnB24                       |
| 6865h<br>Axis B | 0               | Following error window         | UDINT     | RW     | No          | Yes                            | 5242880          | 0           | 1073741823  | Pos. unit | PnB26                       |
| 6866h<br>Axis B | 0               | Following error time out       | UINT      | RW     | No          | Yes                            | 0                | 0           | 65535       | ms        | PnB28                       |
| 6867h<br>Axis B | 0               | Position window                | UDINT     | RW     | No          | Yes                            | 30               | 0           | 1073741823  | Pos. unit | PnB2A                       |
| 6868h<br>Axis B | 0               | Position window time           | UINT      | RW     | No          | Yes                            | 0                | 0           | 65535       | ms        | PnB2C                       |
| 686Bh<br>Axis B | 0               | Velocity demand value          | DINT      | RO     | Yes         | No                             | -                | -           | -           | Vel. Unit | PnB2E                       |
| 686Ch<br>Axis B | 0               | Velocity actual value          | DINT      | RO     | Yes         | No                             | -                | -           | -           | Vel. Unit | PnB30                       |
| 686Dh<br>Axis B | 0               | Velocity window                | UINT      | RW     | No          | Yes                            | 20000            | 0           | 65535       | Vel. Unit | PnB32                       |
| 686Eh<br>Axis B | 0               | Velocity window time           | UINT      | RW     | No          | Yes                            | 0                | 0           | 65535       | ms        | PnB34                       |
| 6871h<br>Axis B | 0               | Target torque                  | INT       | RW     | Yes         | No                             | 0                | -32768      | 32767       | 0.1 %     | PnB36                       |
| 6872h<br>Axis B | 0               | Max torque                     | UINT      | RW     | Yes         | No                             | Motor max torque | 0           | 65535       | 0.1 %     | PnB38                       |
| 6874h<br>Axis B | 0               | Max current                    | INT       | RO     | Yes         | No                             | -                | -           | -           | 0.1 %     | PnB3A                       |

Continued on next page.



Continued from previous page.

| Index                   | Sub-index | Name                           | Data Type | Access | PDO Mapping | Saving to EEPROM <sup>1</sup> | Default Value | Lower Limit | Upper Limit | Unit      | Parameter No. <sup>2</sup> |
|-------------------------|-----------|--------------------------------|-----------|--------|-------------|-------------------------------|---------------|-------------|-------------|-----------|----------------------------|
| 6876h<br>Axis B         | 0         | Motor rated torque             | UDINT     | RO     | No          | No                            | -             | -           | -           | mNm, mN   | PnB3C                      |
| 6877h<br>Axis B         | 0         | Torque actual value            | INT       | RO     | Yes         | No                            | -             | -           | -           | 0.1 %     | PnB3E                      |
| 687Ah<br>Axis B         | 0         | Target position                | DINT      | RW     | Yes         | No                            | 0             | -2147483648 | 2147483647  | Pos. unit | PnB40                      |
| 687Ch<br>Axis B         | -         | Home offset                    | DINT      | RW     | No          | Yes                           | 0             | -536870912  | 536870911   | Pos. unit | PnB46                      |
| Software position limit |           |                                |           |        |             |                               |               |             |             |           |                            |
| 687Dh<br>Axis B         | 0         | Number of entries              | USINT     | RO     | No          | No                            | 2             | -           | -           | -         | -                          |
|                         | 1         | Min position limit             | DINT      | RW     | No          | Yes                           | 0             | -536870912  | 536870911   | Pos. unit | PnB48                      |
|                         | 2         | Max position limit             | DINT      | RW     | No          | Yes                           | 0             | -536870912  | 536870911   | Pos. unit | PnB4A                      |
| 687Fh<br>Axis B         | 0         | Max profile velocity           | UDINT     | RW     | Yes         | Yes                           | 2147483647    | 0           | 4294967295  | Vel. Unit | PnB4C                      |
| 6881h<br>Axis B         | 0         | Profile velocity               | UDINT     | RW     | Yes         | Yes                           | 0             | 0           | 4294967295  | Vel. Unit | PnB4E                      |
| 6883h<br>Axis B         | 0         | Profile acceleration           | UDINT     | RW     | Yes         | Yes                           | 1000          | 0           | 4294967295  | Acc. Unit | PnB50                      |
| 6884h<br>Axis B         | 0         | Profile deceleration           | UDINT     | RW     | Yes         | Yes                           | 1000          | 0           | 4294967295  | Acc. Unit | PnB52                      |
| 6885h<br>Axis B         | 0         | Quick stop deceleration        | UDINT     | RW     | Yes         | Yes                           | 1000          | 0           | 4294967295  | Acc. Unit | PnB54                      |
| 6886h<br>Axis B         | 0         | Motion profile type            | INT       | RW     | Yes         | Yes                           | 0             | 32768       | 32767       | -         | PnB98 <sup>*4</sup>        |
| 6887h<br>Axis B         | 0         | Torque slope                   | UDINT     | RW     | Yes         | Yes                           | 1000          | 0           | 4294967295  | 0.1 %/s   | PnB56                      |
| 6898h<br>Axis B         | 0         | Homing method                  | SINT      | RW     | Yes         | No                            | 35            | 0           | 35          | -         | PnB58                      |
| Homing speeds           |           |                                |           |        |             |                               |               |             |             |           |                            |
| 6899h<br>Axis B         | 0         | Number of entries              | USINT     | RO     | No          | No                            | 2             | -           | -           | -         | -                          |
|                         | 1         | Speed during search for switch | UDINT     | RW     | Yes         | Yes                           | 500000        | 0           | 4294967295  | Vel. Unit | PnB5A                      |
|                         | 2         | Speed during search for zero   | UDINT     | RW     | Yes         | Yes                           | 100000        | 0           | 4294967295  | Vel. Unit | PnB5C                      |
| 689Ah<br>Axis B         | 0         | Homing acceleration            | UDINT     | RW     | Yes         | Yes                           | 1000          | 0           | 4294967295  | Acc. Unit | PnB5E                      |
| Profile jerk            |           |                                |           |        |             |                               |               |             |             |           |                            |
| 68A4h<br>Axis B         | 0         | Number of entries              | USINT     | RO     | No          | No                            | 1             | -           | -           | -         | -                          |
|                         | 1         | Profile jerk1                  | UDINT     | RW     | Yes         | No                            | 25            | 0           | 50          | %         | PnB9A <sup>*4</sup>        |
| 68B1h<br>Axis B         | 0         | Velocity offset                | DINT      | RW     | Yes         | No                            | 0             | -2147483648 | 2147483647  | Vel. Unit | PnB60                      |
| 68B2h<br>Axis B         | 0         | Torque offset                  | INT       | RW     | Yes         | No                            | 0             | -32768      | 32767       | 0.1 %     | PnB62                      |
| 68B8h<br>Axis B         | 0         | Touch probe function           | UINT      | RW     | Yes         | No                            | 0             | 0           | 0xFFFF      | -         | PnB64                      |
| 68B9h<br>Axis B         | 0         | Touch probe status             | UINT      | RO     | Yes         | No                            | -             | -           | -           | -         | PnB66 <sup>*4</sup>        |
| 68BAh<br>Axis B         | 0         | Touch probe pos1 pos value     | DINT      | RO     | Yes         | No                            | -             | -           | -           | Pos. unit | PnB68 <sup>*4</sup>        |
| 68BCh<br>Axis B         | 0         | Touch probe pos2 pos value     | DINT      | RO     | Yes         | No                            | -             | -           | -           | Pos. unit | PnB6A <sup>*4</sup>        |
| 68C0h<br>Axis B         | 0         | Interpolation sub mode select  | INT       | RW     | No          | No                            | 0             | -3          | 0           | -         | PnB92                      |

Continued on next page.

Continued from previous page.

| Index           | Sub-index                        | Name                            | Data Type | Access | PDO Mapping | Saving to EEPROM*1 | Default Value | Lower Limit | Upper Limit | Unit      | Parameter No.*2 |
|-----------------|----------------------------------|---------------------------------|-----------|--------|-------------|--------------------|---------------|-------------|-------------|-----------|-----------------|
| 68C1h<br>Axis B | Interpolation data record        |                                 |           |        |             |                    |               |             |             |           |                 |
|                 | 0                                | Number of entries               | USINT     | RO     | No          | No                 | 1             | -           | -           | -         | -               |
|                 | 1                                | Interpolation data record       | DINT      | RW     | Yes         | No                 | 0             | -2147483648 | 2147483647  | Pos. unit | PnB70           |
| 68C2h<br>Axis B | Interpolation time period        |                                 |           |        |             |                    |               |             |             |           |                 |
|                 | 0                                | Number of entries               | USINT     | RO     | No          | No                 | 2             | -           | -           | -         | -               |
|                 | 1                                | Interpolation time period value | USINT     | RW     | No          | No                 | 125           | 1           | 250         | -         | PnB6E           |
|                 | 2                                | Interpolation time index        | SINT      | RW     | No          | No                 | -6            | -6          | -3          | -         | PnB6F           |
| 68E0h<br>Axis B | 0                                | Positive torque limit value     | UINT      | RW     | Yes         | Yes                | 8000          | 0           | 65535       | 0.1 %     | PnB80           |
| 68E1h<br>Axis B | 0                                | Negative torque limit value     | UINT      | RW     | Yes         | Yes                | 8000          | 0           | 65535       | 0.1 %     | PnB82           |
| 68E4h<br>Axis B | Additional position actual value |                                 |           |        |             |                    |               |             |             |           |                 |
|                 | 0                                | Number of entries               | UINT      | RO     | No          | No                 | 1             | -           | -           | -         | -               |
|                 | 1                                | External encoder position       | UINT      | RO     | Yes         | Yes                | 0             | -           | -           | -         | -               |
| 68F4h<br>Axis B | 0                                | Following error actual value    | DINT      | RO     | Yes         | No                 | -             | -           | -           | Pos. unit | PnB84*4         |
| 68FCh<br>Axis B | 0                                | Position demand internal value  | DINT      | RO     | Yes         | No                 | -             | -           | -           | Inc       | PnB86*4         |
| 68FDh<br>Axis B | 0                                | Digital inputs                  | UDINT     | RO     | Yes         | No                 | -             | -           | -           | -         | PnB88*4         |
| 68FEh<br>Axis B | Digital outputs                  |                                 |           |        |             |                    |               |             |             |           |                 |
|                 | 0                                | Number of entries               | USINT     | RO     | No          | No                 | 2             | -           | -           | -         | -               |
|                 | 1                                | Physical outputs                | UDINT     | RW     | Yes         | No                 | 0             | 0           | 0xFFFFFFFF  | -         | PnB8A           |
|                 | 2                                | Bit mask                        | UDINT     | RW     | No          | Yes                | 0x000C0000    | 0           | 0xFFFFFFFF  | -         | PnB8C           |
| 68FFh<br>Axis B | 0                                | Target velocity                 | DINT      | RW     | Yes         | No                 | 0             | -2147483648 | 2147483647  | Vel. Unit | PnB8E           |
| 6D02h<br>Axis B | 0                                | Supported drive modes           | UDINT     | RO     | No          | No                 | 0x03ED        | -           | -           | -         | PnB90*4         |

- \*1. Write "Save" to object 1010h to save all of the current parameter data to EEPROM.  
If the objects are modified by the Digital Operator or SigmaWin+, the data will be directly saved in EEPROM.
- \*2. The parameter numbers given in the table are the parameter numbers that are used with the Digital Operator and SigmaWin+.
- \*3. These parameters cannot be written by the Digital Operator.
- \*4. These parameters are not displayed on the SigmaWin+.
- \*5. For SGD7W-□□□□DA0: 0x02200402.
- \*6. Both 10F1h and 1F01h have the same function. You can set either object.
- \*7. Refer to the following sections for details.  
 **16.1.2 List of Parameters on page 16-3**  
 Only the parameters listed in this section are displayed in the SigmaWin+ and Digital Operator.

## 16.3 SDO Abort Code List

The following table gives the SDO abort codes for SDO communications errors.

| Value         | Meaning  |
|---------------|--|
| 0x05 03 00 00 | Toggle bit did not change.   |
| 0x05 04 00 00 | SDO protocol timeout   |
| 0x05 04 00 01 | Client/server command specifier is not valid or is unknown.                                  |
| 0x05 04 00 05 | Out of memory  |
| 0x06 01 00 00 | Unsupported access to an object  |
| 0x06 01 00 01 | Attempt to read to a write-only object   |
| 0x06 01 00 02 | Attempt to write to a read-only object   |
| 0x06 02 00 00 | The object does not exist in the object directory.   |
| 0x06 04 00 41 | The object cannot be mapped to the PDO.  |
| 0x06 04 00 42 | The number and length of the objects to be mapped would exceed the PDO length.               |
| 0x06 04 00 43 | General parameter incompatibility  |
| 0x06 04 00 47 | General internal incompatibility in the device   |
| 0x06 06 00 00 | Access failed due to a hardware error.   |
| 0x06 07 00 10 | Data type does not match: length of service parameter does not match.                        |
| 0x06 07 00 12 | Data type does not match: service parameter too long.  |
| 0x06 07 00 13 | Data type does not match: service parameter too short.                                       |
| 0x06 09 00 11 | Subindex does not exist.   |
| 0x06 09 00 30 | Value range of parameter was exceeded (only for write access).                               |
| 0x06 09 00 31 | Value of parameter that was written is too high.   |
| 0x06 09 00 32 | Value of parameter that was written is too low.  |
| 0x06 09 00 36 | The maximum value is less than the minimum value.  |
| 0x08 00 00 00 | General error  |
| 0x08 00 00 20 | Data cannot be transferred or stored to the application.                                     |
| 0x08 00 00 21 | Data cannot be transferred or stored to the application because of local control.            |
| 0x08 00 00 22 | Data cannot be transferred or stored to the application because of the present device state. |

## 16.4 Parameter Recording Table

Use the following table to record the settings of the parameters.

| Parameter No. | Default Setting |  |  |  |  | Name                                     | When Enabled  |
|---------------|-----------------|--|--|--|--|--|---------------|
| Pn000 (2000h) | 0000h           |  |  |  |  | Basic Function Selections 0              | After restart |
| Pn001 (2001h) | 0000h           |  |  |  |  | Application Function Selections 1        | After restart |
| Pn002 (2002h) | 0001h           |  |  |  |  | Application Function Selections 2        | After restart |
| Pn006 (2006h) | 0002h           |  |  |  |  | Application Function Selections 6        | Immediately   |
| Pn007 (2007h) | 0000h           |  |  |  |  | Application Function Selections 7        | Immediately   |
| Pn008 (2008h) | 4000h           |  |  |  |  | Application Function Selections 8        | After restart |
| Pn009 (2009h) | 0010h           |  |  |  |  | Application Function Selections 9        | After restart |
| Pn00A (200Ah) | 0001h           |  |  |  |  | Application Function Selections A        | After restart |
| Pn00B (200Bh) | 0000h           |  |  |  |  | Application Function Selections B        | After restart |
| Pn00C (200Ch) | 0000h           |  |  |  |  | Application Function Selections C        | After restart |
| Pn00D (200Dh) | 0000h           |  |  |  |  | Application Function Selections D        | Immediately   |
| Pn00F (200Fh) | 0000h           |  |  |  |  | Application Function Selections F        | After restart |
| Pn022 (2022h) | 0000h           |  |  |  |  | Application Function Selections 22       | After restart |
| Pn023 (2023h) | 0000h           |  |  |  |  | Application Function Selections 23       | After restart |
| Pn080 (2080h) | 0000h           |  |  |  |  | Application Function Selections 80       | After restart |
| Pn100 (2100h) | 400             |  |  |  |  | Speed Loop Gain                          | Immediately   |
| Pn101 (2101h) | 2000            |  |  |  |  | Speed Loop Integral Time Constant        | Immediately   |
| Pn102 (2102h) | 400             |  |  |  |  | Position Loop Gain                       | Immediately   |
| Pn103 (2103h) | 100             |  |  |  |  | Moment of Inertia Ratio                  | Immediately   |
| Pn104 (2104h) | 400             |  |  |  |  | Second Speed Loop Gain                   | Immediately   |
| Pn105 (2105h) | 2000            |  |  |  |  | Second Speed Loop Integral Time Constant | Immediately   |
| Pn106 (2106h) | 400             |  |  |  |  | Second Position Loop Gain                | Immediately   |
| Pn109 (2109h) | 0               |  |  |  |  | Feedforward                              | Immediately   |
| Pn10A (210Ah) | 0               |  |  |  |  | Feedforward Filter Time Constant         | Immediately   |
| Pn10B (210Bh) | 0000h           |  |  |  |  | Gain Application Selections              | *             |

Continued on next page.

Continued from previous page.

| Parameter No.    | Default Setting |  |  |  |  |  | Name   | When Enabled |
|------------------|-----------------|--|--|--|--|--|--|--------------|
| Pn10C<br>(210Ch) | 200             |  |  |  |  |  | Mode Switching Level for Torque Reference              | Immediately  |
| Pn10D<br>(210Dh) | 0               |  |  |  |  |  | Mode Switching Level for Speed Reference               | Immediately  |
| Pn10E<br>(210Eh) | 0               |  |  |  |  |  | Mode Switching Level for Acceleration                  | Immediately  |
| Pn10F<br>(210Fh) | 0               |  |  |  |  |  | Mode Switching Level for Position Deviation            | Immediately  |
| Pn11F<br>(211Fh) | 0               |  |  |  |  |  | Position Integral Time Constant                        | Immediately  |
| Pn121<br>(2121h) | 100             |  |  |  |  |  | Friction Compensation Gain                             | Immediately  |
| Pn122<br>(2122h) | 100             |  |  |  |  |  | Second Friction Compensation Gain                      | Immediately  |
| Pn123<br>(2123h) | 0               |  |  |  |  |  | Friction Compensation Coefficient                      | Immediately  |
| Pn124<br>(2124h) | 0               |  |  |  |  |  | Friction Compensation Frequency Correction             | Immediately  |
| Pn125<br>(2125h) | 100             |  |  |  |  |  | Friction Compensation Gain Correction                  | Immediately  |
| Pn131<br>(2131h) | 0               |  |  |  |  |  | Gain Switching Time 1                                  | Immediately  |
| Pn132<br>(2132h) | 0               |  |  |  |  |  | Gain Switching Time 2                                  | Immediately  |
| Pn135<br>(2135h) | 0               |  |  |  |  |  | Gain Switching Waiting Time 1                          | Immediately  |
| Pn136<br>(2136h) | 0               |  |  |  |  |  | Gain Switching Waiting Time 2                          | Immediately  |
| Pn139<br>(2139h) | 0000h           |  |  |  |  |  | Automatic Gain Switching Selections 1                  | Immediately  |
| Pn13D<br>(213Dh) | 2000            |  |  |  |  |  | Current Gain Level                                     | Immediately  |
| Pn140<br>(2140h) | 0100h           |  |  |  |  |  | Model Following Control-Related Selections             | Immediately  |
| Pn141<br>(2141h) | 500             |  |  |  |  |  | Model Following Control Gain                           | Immediately  |
| Pn142<br>(2142h) | 1000            |  |  |  |  |  | Model Following Control Gain Correction                | Immediately  |
| Pn143<br>(2143h) | 1000            |  |  |  |  |  | Model Following Control Bias in the Forward Direction  | Immediately  |
| Pn144<br>(2144h) | 1000            |  |  |  |  |  | Model Following Control Bias in the Reverse Direction  | Immediately  |
| Pn145<br>(2145h) | 500             |  |  |  |  |  | Vibration Suppression 1 Frequency A                    | Immediately  |
| Pn146<br>(2146h) | 700             |  |  |  |  |  | Vibration Suppression 1 Frequency B                    | Immediately  |
| Pn147<br>(2147h) | 1000            |  |  |  |  |  | Model Following Control Speed Feedforward Compensation | Immediately  |
| Pn148<br>(2148h) | 500             |  |  |  |  |  | Second Model Following Control Gain                    | Immediately  |
| Pn149<br>(2149h) | 1000            |  |  |  |  |  | Second Model Following Gain Control Correction         | Immediately  |

Continued on next page.

Continued from previous page.

| Parameter No. | Default Setting |  |  |  |  |  | Name   | When Enabled  |
|---------------|-----------------|--|--|--|--|--|--|---------------|
| Pn14A (214Ah) | 800             |  |  |  |  |  | Vibration Suppression 2 Frequency                | Immediately   |
| Pn14B (214Bh) | 100             |  |  |  |  |  | Vibration Suppression 2 Correction               | Immediately   |
| Pn14F (214Fh) | 0021h           |  |  |  |  |  | Control-Related Selections                       | After restart |
| Pn160 (2160h) | 0010h           |  |  |  |  |  | Anti-Resonance Control-Related Selections        | Immediately   |
| Pn161 (2161h) | 1000            |  |  |  |  |  | Anti-Resonance Frequency                         | Immediately   |
| Pn162 (2162h) | 100             |  |  |  |  |  | Anti-Resonance Gain Correction                   | Immediately   |
| Pn163 (2163h) | 0               |  |  |  |  |  | Anti-Resonance Damping Gain                      | Immediately   |
| Pn164 (2164h) | 0               |  |  |  |  |  | Anti-Resonance Filter Time Constant 1 Correction | Immediately   |
| Pn165 (2165h) | 0               |  |  |  |  |  | Anti-Resonance Filter Time Constant 2 Correction | Immediately   |
| Pn166 (2166h) | 0               |  |  |  |  |  | Anti-Resonance Damping Gain 2                    | Immediately   |
| Pn170 (2170h) | 1401h           |  |  |  |  |  | Tuning-less Function-Related Selections          | *             |
| Pn181 (2181h) | 0               |  |  |  |  |  | Mode Switching Level for Speed Reference         | Immediately   |
| Pn182 (2182h) | 0               |  |  |  |  |  | Mode Switching Level for Acceleration            | Immediately   |
| Pn205 (2205h) | 65535           |  |  |  |  |  | Multiturn Limit                                  | After restart |
| Pn207 (2207h) | 0010h           |  |  |  |  |  | Position Control Function Selections             | After restart |
| Pn20E (220Eh) | 1               |  |  |  |  |  | Electronic Gear Ratio (Numerator)                | After restart |
| Pn210 (2210h) | 1               |  |  |  |  |  | Electronic Gear Ratio (Denominator)              | After restart |
| Pn230 (2230h) | 0000h           |  |  |  |  |  | Position Control Expansion Function Selections   | After restart |
| Pn231 (2231h) | 0               |  |  |  |  |  | Backlash Compensation                            | Immediately   |
| Pn233 (2233h) | 0               |  |  |  |  |  | Backlash Compensation Time Constant              | Immediately   |
| Pn282 (2282h) | 0               |  |  |  |  |  | Linear Encoder Pitch                             | After restart |
| Pn304 (2304h) | 500             |  |  |  |  |  | Jogging Speed                                    | Immediately   |
| Pn305 (2305h) | 0               |  |  |  |  |  | Soft Start Acceleration Time                     | Immediately   |
| Pn306 (2306h) | 0               |  |  |  |  |  | Soft Start Deceleration Time                     | Immediately   |
| Pn308 (2308h) | 0               |  |  |  |  |  | Speed Feedback Filter Time Constant              | Immediately   |
| Pn30A (230Ah) | 0               |  |  |  |  |  | Deceleration Time for Servo OFF and Forced Stops | Immediately   |
| Pn30C (230Ch) | 0               |  |  |  |  |  | Speed Feedforward Average Movement Time          | Immediately   |

Continued on next page.

Continued from previous page.

| Parameter No.    | Default Setting |  |  |  |  | Name   | When Enabled  |
|------------------|-----------------|--|--|--|--|--|---------------|
| Pn310<br>(2310h) | 0000h           |  |  |  |  | Vibration Detection Selections                           | Immediately   |
| Pn311<br>(2311h) | 100             |  |  |  |  | Vibration Detection Sensitivity                          | Immediately   |
| Pn312<br>(2312h) | 50              |  |  |  |  | Vibration Detection Level                                | Immediately   |
| Pn316<br>(2316h) | 10000           |  |  |  |  | Maximum Motor Speed                                      | After restart |
| Pn324<br>(2324h) | 300             |  |  |  |  | Moment of Inertia Calculation Starting Level             | Immediately   |
| Pn383<br>(2383h) | 50              |  |  |  |  | Jogging Speed  | Immediately   |
| Pn384<br>(2384h) | 10              |  |  |  |  | Vibration Detection Level                                | Immediately   |
| Pn385<br>(2385h) | 50              |  |  |  |  | Maximum Motor Speed                                      | After restart |
| Pn401<br>(2401h) | 100             |  |  |  |  | First Stage First Torque Reference Filter Time Constant  | Immediately   |
| Pn402<br>(2402h) | 800             |  |  |  |  | Forward Torque Limit                                     | Immediately   |
| Pn403<br>(2403h) | 800             |  |  |  |  | Reverse Torque Limit                                     | Immediately   |
| Pn404<br>(2404h) | 100             |  |  |  |  | Forward External Torque Limit                            | Immediately   |
| Pn405<br>(2405h) | 100             |  |  |  |  | Reverse External Torque Limit                            | Immediately   |
| Pn406<br>(2406h) | 800             |  |  |  |  | Emergency Stop Torque                                    | Immediately   |
| Pn407<br>(2407h) | 10000           |  |  |  |  | Speed Limit during Torque Control                        | Immediately   |
| Pn408<br>(2408h) | 0000h           |  |  |  |  | Torque-Related Function Selections                       | *             |
| Pn409<br>(2409h) | 5000            |  |  |  |  | First Stage Notch Filter Frequency                       | Immediately   |
| Pn40A<br>(240Ah) | 70              |  |  |  |  | First Stage Notch Filter Q Value                         | Immediately   |
| Pn40B<br>(240Bh) | 0               |  |  |  |  | First Stage Notch Filter Depth                           | Immediately   |
| Pn40C<br>(240Ch) | 5000            |  |  |  |  | Second Stage Notch Filter Frequency                      | Immediately   |
| Pn40D<br>(240Dh) | 70              |  |  |  |  | Second Stage Notch Filter Q Value                        | Immediately   |
| Pn40E<br>(240Eh) | 0               |  |  |  |  | Second Stage Notch Filter Depth                          | Immediately   |
| Pn40F<br>(240Fh) | 5000            |  |  |  |  | Second Stage Second Torque Reference Filter Frequency    | Immediately   |
| Pn410<br>(2410h) | 50              |  |  |  |  | Second Stage Second Torque Reference Filter Q Value      | Immediately   |
| Pn412<br>(2412h) | 100             |  |  |  |  | First Stage Second Torque Reference Filter Time Constant | Immediately   |

Continued on next page.

Continued from previous page.

| Parameter No.    | Default Setting |  |  |  |  |  | Name  | When Enabled  |
|------------------|-----------------|--|--|--|--|--|---|---------------|
| Pn416<br>(2416h) | 0000h           |  |  |  |  |  | Torque-Related Function Selections 2                        | Immediately   |
| Pn417<br>(2417h) | 5000            |  |  |  |  |  | Third Stage Notch Filter Frequency                          | Immediately   |
| Pn418<br>(2418h) | 70              |  |  |  |  |  | Third Stage Notch Filter Q Value                            | Immediately   |
| Pn419<br>(2419h) | 0               |  |  |  |  |  | Third Stage Notch Filter Depth                              | Immediately   |
| Pn41A<br>(241Ah) | 5000            |  |  |  |  |  | Fourth Stage Notch Filter Frequency                         | Immediately   |
| Pn41B<br>(241Bh) | 70              |  |  |  |  |  | Fourth Stage Notch Filter Q Value                           | Immediately   |
| Pn41C<br>(241Ch) | 0               |  |  |  |  |  | Fourth Stage Notch Filter Depth                             | Immediately   |
| Pn41D<br>(241Dh) | 5000            |  |  |  |  |  | Fifth Stage Notch Filter Frequency                          | Immediately   |
| Pn41E<br>(241Eh) | 70              |  |  |  |  |  | Fifth Stage Notch Filter Q Value                            | Immediately   |
| Pn41F<br>(241Fh) | 0               |  |  |  |  |  | Fifth Stage Notch Filter Depth                              | Immediately   |
| Pn423<br>(2423h) | 0000h           |  |  |  |  |  | Speed Ripple Compensation Selections                        | *             |
| Pn424<br>(2424h) | 50              |  |  |  |  |  | Torque Limit at Main Circuit Voltage Drop                   | Immediately   |
| Pn425<br>(2425h) | 100             |  |  |  |  |  | Release Time for Torque Limit at Main Circuit Voltage Drop  | Immediately   |
| Pn426<br>(2426h) | 0               |  |  |  |  |  | Torque Feedforward Average Movement Time                    | Immediately   |
| Pn427<br>(2427h) | 0               |  |  |  |  |  | Speed Ripple Compensation Enable Speed                      | Immediately   |
| Pn456<br>(2456h) | 15              |  |  |  |  |  | Sweep Torque Reference Amplitude                            | Immediately   |
| Pn460<br>(2460h) | 0101h           |  |  |  |  |  | Notch Filter Adjustment Selections 1                        | Immediately   |
| Pn475<br>(2475h) | 0000h           |  |  |  |  |  | Gravity Compensation-Related Selections                     | After restart |
| Pn476<br>(2476h) | 0               |  |  |  |  |  | Gravity Compensation Torque                                 | Immediately   |
| Pn480<br>(2480h) | 10000           |  |  |  |  |  | Speed Limit during Force Control                            | Immediately   |
| Pn481<br>(2481h) | 400             |  |  |  |  |  | Polarity Detection Speed Loop Gain                          | Immediately   |
| Pn482<br>(2482h) | 3000            |  |  |  |  |  | Polarity Detection Speed Loop Integral Time Constant        | Immediately   |
| Pn483<br>(2483h) | 30              |  |  |  |  |  | Forward Force Limit   | Immediately   |
| Pn484<br>(2484h) | 30              |  |  |  |  |  | Reverse Force Limit   | Immediately   |
| Pn485<br>(2485h) | 20              |  |  |  |  |  | Polarity Detection Reference Speed                          | Immediately   |
| Pn486<br>(2486h) | 25              |  |  |  |  |  | Polarity Detection Reference Acceleration/Deceleration Time | Immediately   |

Continued on next page.



Continued from previous page.

| Parameter No.    | Default Setting |  |  |  |  |  | Name  | When Enabled  |
|------------------|-----------------|--|--|--|--|--|---|---------------|
| Pn487<br>(2487h) | 0               |  |  |  |  |  | Polarity Detection Constant Speed Time          | Immediately   |
| Pn488<br>(2488h) | 100             |  |  |  |  |  | Polarity Detection Reference Waiting Time       | Immediately   |
| Pn48E<br>(248Eh) | 10              |  |  |  |  |  | Polarity Detection Range                        | Immediately   |
| Pn490<br>(2490h) | 100             |  |  |  |  |  | Polarity Detection Load Level                   | Immediately   |
| Pn495<br>(2495h) | 100             |  |  |  |  |  | Polarity Detection Confirmation Force Reference | Immediately   |
| Pn498<br>(2498h) | 10              |  |  |  |  |  | Polarity Detection Allowable Error Range        | Immediately   |
| Pn49F<br>(249Fh) | 0               |  |  |  |  |  | Speed Ripple Compensation Enable Speed          | Immediately   |
| Pn502<br>(2502h) | 20              |  |  |  |  |  | Rotation Detection Level                        | Immediately   |
| Pn503<br>(2503h) | 10              |  |  |  |  |  | Speed Coincidence Detection Signal Output Width | Immediately   |
| Pn506<br>(2506h) | 0               |  |  |  |  |  | Brake Reference-Servo OFF Delay Time            | Immediately   |
| Pn507<br>(2507h) | 100             |  |  |  |  |  | Brake Reference Output Speed Level              | Immediately   |
| Pn508<br>(2508h) | 50              |  |  |  |  |  | Servo OFF-Brake Command Waiting Time            | Immediately   |
| Pn509<br>(2509h) | 20              |  |  |  |  |  | Momentary Power Interruption Hold Time          | Immediately   |
| Pn50A<br>(250Ah) | 1881h           |  |  |  |  |  | Input Signal Selections 1                       | After restart |
| Pn50B<br>(250Bh) | 8882h           |  |  |  |  |  | Input Signal Selections 2                       | After restart |
| Pn50E<br>(250Eh) | 0000h           |  |  |  |  |  | Output Signal Selections 1                      | After restart |
| Pn50F<br>(250Fh) | 0100h           |  |  |  |  |  | Output Signal Selections 2                      | After restart |
| Pn510<br>(2510h) | 0000h           |  |  |  |  |  | Output Signal Selections 3                      | After restart |
| Pn511<br>(2511h) | 5432h           |  |  |  |  |  | Input Signal Selections 5                       | After restart |
| Pn512<br>(2512h) | 0000h           |  |  |  |  |  | Output Signal Inverse Settings 1                | After restart |
| Pn514<br>(2514h) | 0000h           |  |  |  |  |  | Output Signal Selections 4                      | After restart |
| Pn516<br>(2516h) | 8888h           |  |  |  |  |  | Input Signal Selections 7                       | After restart |
| Pn51E<br>(251Eh) | 100             |  |  |  |  |  | Position Deviation Overflow Warning Level       | Immediately   |
| Pn520<br>(2520h) | 5242880         |  |  |  |  |  | Position Deviation Overflow Alarm Level         | Immediately   |
| Pn522<br>(2522h) | 7               |  |  |  |  |  | Positioning Completed Width                     | Immediately   |
| Pn524<br>(2524h) | 1073741824      |  |  |  |  |  | Near Signal Width                               | Immediately   |

Continued on next page.

Continued from previous page.

| Parameter No. | Default Setting |  |  |  |  |  | Name   | When Enabled  |
|---------------|-----------------|--|--|--|--|--|--|---------------|
| Pn526 (2526h) | 5242880         |  |  |  |  |  | Position Deviation Overflow Alarm Level at Servo ON                | Immediately   |
| Pn528 (2528h) | 100             |  |  |  |  |  | Position Deviation Overflow Warning Level at Servo ON              | Immediately   |
| Pn529 (2529h) | 10000           |  |  |  |  |  | Speed Limit Level at Servo ON                                      | Immediately   |
| Pn52B (252Bh) | 20              |  |  |  |  |  | Overload Warning Level   | Immediately   |
| Pn52C (252Ch) | 100             |  |  |  |  |  | Base Current Derating at Motor Overload Detection                  | After restart |
| Pn530 (2530h) | 0000h           |  |  |  |  |  | Program Jogging-Related Selections                                 | Immediately   |
| Pn531 (2531h) | 32768           |  |  |  |  |  | Program Jogging Travel Distance                                    | Immediately   |
| Pn533 (2533h) | 500             |  |  |  |  |  | Program Jogging Movement Speed                                     | Immediately   |
| Pn534 (2534h) | 100             |  |  |  |  |  | Program Jogging Acceleration/Deceleration Time                     | Immediately   |
| Pn535 (2535h) | 100             |  |  |  |  |  | Program Jogging Waiting Time                                       | Immediately   |
| Pn536 (2536h) | 1               |  |  |  |  |  | Program Jogging Number of Movements                                | Immediately   |
| Pn550 (2550h) | 0               |  |  |  |  |  | Analog Monitor 1 Offset Voltage                                    | Immediately   |
| Pn551 (2551h) | 0               |  |  |  |  |  | Analog Monitor 2 Offset Voltage                                    | Immediately   |
| Pn552 (2552h) | 100             |  |  |  |  |  | Analog Monitor 1 Magnification                                     | Immediately   |
| Pn553 (2553h) | 100             |  |  |  |  |  | Analog Monitor 2 Magnification                                     | Immediately   |
| Pn55A (255Ah) | 1               |  |  |  |  |  | Power Consumption Monitor Unit Time                                | Immediately   |
| Pn560 (2560h) | 400             |  |  |  |  |  | Residual Vibration Detection Width                                 | Immediately   |
| Pn561 (2561h) | 100             |  |  |  |  |  | Overshoot Detection Level  | Immediately   |
| Pn581 (2581h) | 20              |  |  |  |  |  | Zero Speed Level   | Immediately   |
| Pn582 (2582h) | 10              |  |  |  |  |  | Speed Coincidence Detection Signal Output Width                    | Immediately   |
| Pn583 (2583h) | 10              |  |  |  |  |  | Brake Reference Output Speed Level                                 | Immediately   |
| Pn584 (2584h) | 10000           |  |  |  |  |  | Speed Limit Level at Servo ON                                      | Immediately   |
| Pn585 (2585h) | 50              |  |  |  |  |  | Program Jogging Movement Speed                                     | Immediately   |
| Pn586 (2586h) | 0               |  |  |  |  |  | Motor Running Cooling Ratio  | Immediately   |
| Pn587 (2587h) | 0000h           |  |  |  |  |  | Polarity Detection Execution Selection for Absolute Linear Encoder | Immediately   |

Continued on next page.

Continued from previous page.

| Parameter No.    | Default Setting                       |  |  |  |  |  | Name  | When Enabled  |
|------------------|---------------------------------------|--|--|--|--|--|---|---------------|
| Pn590<br>(2590h) | Axis A:<br>1007h,<br>Axis B:<br>1012h |  |  |  |  |  | P-OT (Forward Drive Prohibit) Signal Allocation               | After restart |
| Pn591<br>(2591h) | Axis A:<br>1008h,<br>Axis B:<br>1013h |  |  |  |  |  | N-OT (Reverse Drive Prohibit) Signal Allocation               | After restart |
| Pn593<br>(2593h) | Axis A:<br>1009h,<br>Axis B:<br>1018h |  |  |  |  |  | /Probe1 (Probe 1 Latch Input) Signal Allocation               | After restart |
| Pn594<br>(2594h) | Axis A:<br>1010,<br>Axis B:<br>1019   |  |  |  |  |  | /Probe2 (Probe 2 Latch Input) Signal Allocation               | After restart |
| Pn595<br>(2595h) | Axis A:<br>1011,<br>Axis B:<br>1020   |  |  |  |  |  | /Home (Home Switch Input) Signal Allocation                   | After restart |
| Pn597<br>(2597h) | 0000h                                 |  |  |  |  |  | FSTP (Forced Stop Input) Signal Allocation                    | After restart |
| Pn598<br>(2598h) | 0000h                                 |  |  |  |  |  | /P-CL (Forward External Torque Limit Input) Signal Allocation | After restart |
| Pn599<br>(2599h) | 0000h                                 |  |  |  |  |  | /N-CL (Reverse External Torque Limit Input) Signal Allocation | After restart |
| Pn5B0<br>(25B0h) | 0000h                                 |  |  |  |  |  | /COIN (Positioning Completion Output) Signal Allocation       | After restart |
| Pn5B1<br>(25B1h) | 0000h                                 |  |  |  |  |  | /V-CMP (Speed Coincidence Detection Output) Signal Allocation | After restart |
| Pn5B2<br>(25B2h) | 0000h                                 |  |  |  |  |  | /TGON (Rotation Detection Output) Signal Allocation           | After restart |
| Pn5B3<br>(25B3h) | 0000h                                 |  |  |  |  |  | /S-RDY (Servo Ready) Signal Allocation                        | After restart |
| Pn5B4<br>(25B4h) | 0000h                                 |  |  |  |  |  | /CLT (Torque Limit Detection Output) Signal Allocation        | After restart |
| Pn5B5<br>(25B5h) | 0000h                                 |  |  |  |  |  | /VLT (Speed Limit Detection) Signal Allocation                | After restart |
| Pn5B6<br>(25B6h) | Axis A:<br>1001h,<br>Axis B:<br>1023h |  |  |  |  |  | /BK (Brake Output) Signal Allocation                          | After restart |
| Pn5B7<br>(25B7h) | 0000h                                 |  |  |  |  |  | /WARN (Warning Output) Signal Allocation                      | After restart |
| Pn5B8<br>(25B8h) | 0000h                                 |  |  |  |  |  | /NEAR (Near Output) Signal Allocation                         | After restart |
| Pn5BC<br>(25B9C) | 0000h                                 |  |  |  |  |  | /PM (Preventative Maintenance Output) Signal Allocation       | After restart |
| Pn600<br>(2600h) | 0                                     |  |  |  |  |  | Regenerative Resistor Capacity                                | Immediately   |

Continued on next page.

Continued from previous page.

| Parameter No.    | Default Setting |  |  |  |  |  | Name  | When Enabled  |
|------------------|-----------------|--|--|--|--|--|---|---------------|
| Pn601<br>(2601h) | 0               |  |  |  |  |  | Dynamic Brake Resistor Allowable Energy Consumption | After restart |
| Pn603<br>(2603h) | 0               |  |  |  |  |  | Regenerative Resistance                             | Immediately   |
| Pn604<br>(2604h) | 0               |  |  |  |  |  | Dynamic Brake Resistance                            | After restart |
| Pn61A<br>(261Ah) | 0000h           |  |  |  |  |  | Overheat Protection Selections                      | After restart |
| Pn61B<br>(261Bh) | 250             |  |  |  |  |  | Overheat Alarm Level                                | Immediately   |
| Pn61C<br>(261Ch) | 100             |  |  |  |  |  | Overheat Warning Level                              | Immediately   |
| Pn61D<br>(261Dh) | 0               |  |  |  |  |  | Overheat Alarm Filter Time                          | Immediately   |

\* The enable timing depends on the digit that is changed. Refer to the following sections for details.

 16.1 List of Servo Parameters on page 16-2

# Appendices

---

# 17

The appendix provides information on interpreting panel displays, and tables of corresponding SERVOPACK and SigmaWin+ function names.

## **17.1** Interpreting Panel Displays .....17-2

- 17.1.1 Interpreting Status Displays ..... 17-2
- 17.1.2 Alarm and Warning Displays ..... 17-2
- 17.1.3 Overtravel Display ..... 17-2
- 17.1.4 Forced Stop Display ..... 17-2

## **17.2** Corresponding SERVOPACK and SigmaWin+ Function Names ... 17-3

- 17.2.1 Corresponding SERVOPACK Utility Function Names ..... 17-3
- 17.2.2 Corresponding SERVOPACK Monitor Display Function Names ..... 17-5

# 17.1 Interpreting Panel Displays

You can check the Servo Drive status on the panel display of the SERVOPACK.  
 Also, if an alarm or warning occurs, the alarm or warning number will be displayed.

## 17.1.1 Interpreting Status Displays

The status is displayed as described below.

| Display | Meaning   | Display | Meaning   |
|---------|---|---------|---|
|         | /TGON (Rotation Detection) Signal Display<br>Lit if the Servomotor speed is higher than the setting of Pn502 or Pn581 and not lit if the speed is lower than the setting. (The default setting is 20 min <sup>-1</sup> or 20 mm/s.) |         | Reference Input Display<br>Lit while a reference is being input.                  |
|         | Base Block Display<br>Lit during the base block state (servo OFF). Not lit while the servo is ON.   |         | Control Power Supply ON Display<br>Lit while the control power is being supplied. |

**Information** The locations for the axes on the panel display are as follows:

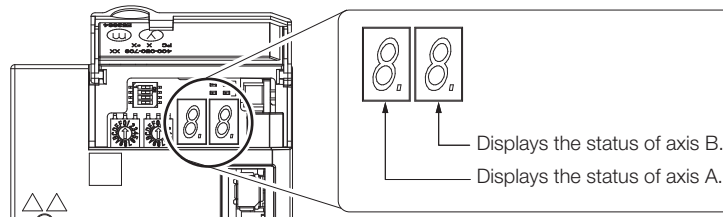

## 17.1.2 Alarm and Warning Displays

If there is an alarm or warning, the display will change in the following order.

Example: Alarm A.E60

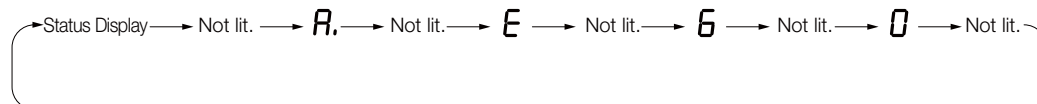

## 17.1.3 Overtravel Display

If overtravel has occurred, the display will change in the following order.

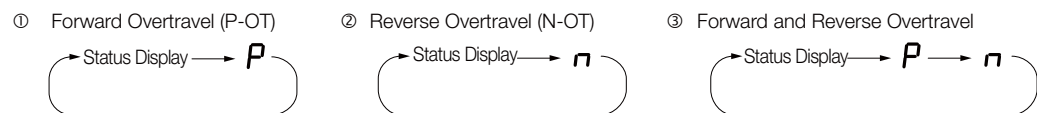

## 17.1.4 Forced Stop Display

During a forced stop, the following display will appear.

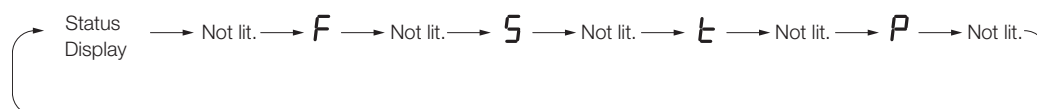

## 17.2 Corresponding SERVOPACK and SigmaWin+ Function Names

This section gives the names and numbers of the utility functions and monitor display functions used by the SERVOPACKs and the names used by the SigmaWin+.

### 17.2.1 Corresponding SERVOPACK Utility Function Names

| SigmaWin+                 |  | SERVOPACK              |  |
|---------------------------|--|------------------------|--|
| Button in Menu Dialog Box | Function Name  | Fn No.                 | Function Name  |
| Basic Functions           | Initialize   | Fn005                  | Initializing Parameters  |
|                           | Software Reset   | Fn030                  | Software Reset   |
|                           | Setup Wizard   | –                      | –  |
|                           | I/O Signal Allocation                                  | –                      | –  |
|                           | Product Information                                    |                        | Fn011  |
| Fn012                     |  |                        | Display Software Version   |
| Fn01E                     |  |                        | Display SERVOPACK and Servomotor IDs                             |
| Fn01F                     |  |                        | Display Servomotor ID from Feedback Option Module                |
| Encoder Setting           | Reset Absolute Encoder                                 | Fn008                  | Reset Absolute Encoder   |
|                           | Multi-turn Limit Setup                                 | Fn013                  | Multiturn Limit Setting after Multiturn Limit Disagreement Alarm |
|                           | Search Origin  | Fn003                  | Origin Search  |
|                           | Zero Point Position Setting                            | Fn020                  | Set Absolute Linear Encoder Origin                               |
|                           | Polarity Detection                                     | Fn080                  | Polarity Detection   |
|                           | Motor Parameter Scale Write                            | –                      | –  |
| Trouble-shooting          | Display Alarm  | Fn000                  | Display Alarm History  |
|                           |  | Fn006                  | Clear Alarm History  |
|                           |  | Fn014                  | Reset Option Module Configuration Error                          |
|                           | Alarm Trace  | –                      | –  |
| Reset Motor Type Alarm    | Fn021  | Reset Motor Type Alarm |  |
| Operation                 | Jog  | Fn002                  | Jog  |
|                           | Program JOG Operation                                  | Fn004                  | Jog Program  |
| Monitor                   | Trace  | –                      | –  |
|                           | Real Time Trace  | –                      | –  |
|                           | Monitor  | –                      | –  |
|                           | Life Monitor   | –                      | –  |
| Tuning                    | Tuning - Autotuning without Host Reference             | Fn201                  | Advanced Autotuning without Reference                            |
|                           | Tuning - Autotuning with Host Reference                | Fn202                  | Advanced Autotuning with Reference                               |
|                           | Tuning - Custom Tuning                                 | Fn203                  | One-Parameter Tuning   |
|                           | Tuning - Custom Tuning - Adjust Anti-resonance Control | Fn204                  | Adjust Anti-resonance Control                                    |
|                           | Tuning - Custom Tuning - Vibration Suppression         | Fn205                  | Vibration Suppression  |
|                           | System Tuning  | –                      | –  |
|                           | Response Level Setting                                 | Fn200                  | Tuning-less Level Setting  |
| Edit Online Parameters    | –  | –                      |  |

Continued on next page.

17.2 Corresponding SERVOPACK and SigmaWin+ Function Names

17.2.1 Corresponding SERVOPACK Utility Function Names

Continued from previous page.

| SigmaWin+                       |  | SERVOPACK |   |
|---------------------------------|--|-----------|---|
| Button in Menu Dialog Box       | Function Name                              | Fn No.    | Function Name   |
| Diagnostic                      | Mechanical Analysis                        | -         | -   |
|                                 | Easy FFT                                   | Fn206     | Easy FFT  |
|                                 | Ripple Compensation                        | -         | -   |
|                                 | Online Vibration Monitor                   | -         | -   |
| Others                          | Adjust the Analog Monitor Output           | Fn00C     | Adjust Analog Monitor Output Offset                   |
|                                 |  | Fn00D     | Adjust Analog Monitor Output Gain                     |
|                                 | Adjust the Motor Current Detection Offsets | Fn00E     | Autotune Motor Current Detection Signal Offset        |
|                                 |  | Fn00F     | Manually Adjust Motor Current Detection Signal Offset |
|                                 | Initialize Vibration Detection Level       | Fn01B     | Initialize Vibration Detection Level                  |
|                                 | Parameter Converter                        | -         | -   |
|                                 | SERVOPACK Axis Name Setting                | -         | -   |
|                                 | Write Prohibited Setting                   | Fn010     | Write Prohibition Setting                             |
| Motor Parameter SERVOPACK Write | -  | -         |   |



## 17.2.2 Corresponding SERVOPACK Monitor Display Function Names

If “Common” is given below the Un number, the monitor display applies to both axes. The total value for all axes or the contents for all axes are displayed on the monitor.

| SigmaWin+   |  | SERVOPACK   |  |
|---|--|---|--|
| Button in Menu Dialog Box                                       | Name [Unit]  | Un No.  | Name [Unit]  |
| Motion Monitor  | Motor Speed [ $\text{min}^{-1}$ ]  | Un000   | Motor Speed [ $\text{min}^{-1}$ ]  |
|   | Speed Reference [ $\text{min}^{-1}$ ]  | Un001   | Speed Reference [ $\text{min}^{-1}$ ]  |
|   | Torque Reference [%]   | Un002   | Torque Reference [%]<br>(percentage of rated torque)   |
|   | <ul style="list-style-type: none"> <li>Rotary Servomotors: Rotational Angle 1 [encoder pulses]<br/>(number of encoder pulses from encoder phase C)</li> <li>Linear Servomotors: Electrical Angle 1 [linear encoder pulses]<br/>(linear encoder pulses from the polarity origin)</li> </ul> | Un003   | <ul style="list-style-type: none"> <li>Rotary Servomotors: Rotational Angle 1 [encoder pulses]<br/>(number of encoder pulses from encoder phase C displayed in decimal)</li> <li>Linear Servomotors: Electrical Angle 1 [linear encoder pulses]<br/>(linear encoder pulses from the polarity origin displayed in decimal)</li> </ul> |
|   | <ul style="list-style-type: none"> <li>Rotary Servomotors: Rotational Angle 2 [deg]<br/>(electrical angle from polarity origin)</li> <li>Linear Servomotors: Electrical Angle 2 [deg]<br/>(electrical angle from polarity origin)</li> </ul>   | Un004   | <ul style="list-style-type: none"> <li>Rotary Servomotors: Rotational Angle 2 [deg]<br/>(electrical angle from polarity origin)</li> <li>Linear Servomotors: Electrical Angle 2 [deg]<br/>(electrical angle from polarity origin)</li> </ul>   |
|   | Input Reference Pulse Speed [ $\text{min}^{-1}$ ]  | Un007   | Input Reference Pulse Speed [ $\text{min}^{-1}$ ]<br>(displayed only during position control)  |
|   | Position Deviation [reference units]   | Un008   | Position Error Amount [reference units]<br>(displayed only during position control)  |
|   | Accumulated Load Ratio [%]   | Un009   | Accumulated Load Ratio [%]<br>(percentage of rated torque: effective torque in cycles of 10 seconds)   |
|   | Regenerative Load Ratio [%]  | Un00A<br>Common   | Regenerative Load Ratio [%]<br>(percentage of processable regenerative power: regenerative power consumption in cycles of 10 seconds)  |
|   | Dynamic Brake Resistor Power Consumption [%]   | Un00B   | Power Consumed by DB Resistance [%]<br>(percentage of processable power at DB activation: displayed in cycles of 10 seconds)   |
|   | Input Reference Pulse Counter [reference units]  | Un00C   | Input Reference Pulse Counter [reference units]  |
|   | Feedback Pulse Counter [encoder pulses]  | Un00D   | Feedback Pulse Counter [encoder pulses]  |
|   | Total Operation Time [100 ms]  | Un012<br>Common   | Total Operation Time [100 ms]  |
|   | Feedback Pulse Counter [reference units]   | Un013   | Feedback Pulse Counter [reference units]   |
|   | Overheat Protection Input [0.01 V]   | Un02F   | Overheat Protection Input [0.01 V]   |
|   | Current Backlash Compensation Value [0.1 reference units]  | Un030   | Current Backlash Compensation Value [0.1 reference units]  |
| Backlash Compensation Value Setting Limit [0.1 reference units] | Un031  | Backlash Compensation Value Setting Limit [0.1 reference units] |  |
| Power Consumption [W]   | Un032<br>Common  | Power Consumption [W]   |  |

Continued on next page.

17.2 Corresponding SERVOPACK and SigmaWin+ Function Names

17.2.2 Corresponding SERVOPACK Monitor Display Function Names

Continued from previous page.

| SigmaWin+                 |   | SERVOPACK              |  |
|---------------------------|---|------------------------|--|
| Button in Menu Dialog Box | Name [Unit]   | Un No.                 | Name [Unit]  |
| Motion Monitor            | Consumed Power [0.001 Wh]   | Un033<br><u>Common</u> | Consumed Power [0.001 Wh]  |
|                           | Cumulative Power Consumption [Wh]                                 | Un034<br><u>Common</u> | Cumulative Power Consumption [Wh]  |
|                           | Absolute Encoder Multiturn Data                                   | Un040                  | Absolute Encoder Multiturn Data  |
|                           | Position within One Rotation of Absolute Encoder [encoder pulses] | Un041                  | Position within One Rotation of Absolute Encoder [encoder pulses]            |
|                           | Lower Bits of Absolute Encoder Position [encoder pulses]          | Un042                  | Lower Bits of Absolute Encoder Position [encoder pulses]                     |
|                           | Upper Bits of Absolute Encoder Position [encoder pulses]          | Un043                  | Upper Bits of Absolute Encoder Position [encoder pulses]                     |
| Status Monitor            | Polarity Sensor Signal Monitor                                    | Un011                  | Polarity Sensor Signal Monitor   |
|                           | Active Gain Monitor   | Un014                  | Effective Gain Monitor (gain settings 1 = 1, gain settings 2 = 2)            |
| Input Signal Monitor      | Input Signal Monitor  | Un005                  | Input Signal Monitor   |
|                           |   | Un050<br><u>Common</u> | All Input Signal Monitor 1   |
|                           |   | Un052<br><u>Common</u> | All Input Signal Monitor 2   |
| Output Signal Monitor     | Output Signal Monitor   | Un006                  | Output Signal Monitor  |
|                           |   | Un051<br><u>Common</u> | All Output Signal Monitor  |
| Service Life Monitor      | Installation Environment Monitor – SERVOPACK                      | Un025<br><u>Common</u> | SERVOPACK Installation Environment Monitor [%]                               |
|                           | Installation Environment Monitor – Servomotor*                    | Un026                  | Servomotor Installation Environment Monitor [%]                              |
|                           | Service Life Prediction Monitor – Built-in Fan                    | Un027<br><u>Common</u> | Built-in Fan Remaining Life Ratio [%]  |
|                           | Service Life Prediction Monitor – Capacitor                       | Un028<br><u>Common</u> | Capacitor Remaining Life Ratio [%]   |
|                           | Service Life Prediction Monitor – Surge Prevention Circuit        | Un029<br><u>Common</u> | Surge Prevention Circuit Remaining Life Ratio [%]                            |
|                           | Service Life Prediction Monitor – Dynamic Brake Circuit           | Un02A                  | Dynamic Brake Circuit Remaining Life Ratio [%]                               |
|                           | Service Life Prediction Monitor – Built-in Brake Relay            | Un036                  | Built-in Brake Relay Remaining Life Ratio [%]                                |
| Product Information       | Motor – Resolution  | Un084                  | Linear Encoder Pitch (Scale pitch = $Un084 \times 10^{Un085}$ [µm])          |
|                           |   | Un085                  | Linear Encoder Pitch Exponent (Scale pitch = $Un084 \times 10^{Un085}$ [µm]) |
| –                         | –   | Un020                  | Rated Motor Speed [ $min^{-1}$ ]   |
|                           | –   | Un021                  | Maximum Motor Speed [ $min^{-1}$ ]   |

\* This applies to the following motors. The display will show 0 for all other models.  
SGM7J, SGM7A, and SGM7G

# Index

## Symbols

|  |      |
|--|------|
| /BK - - - - -  | 6-32 |
| /BK (Brake) signal - - - - -                           | 6-32 |
| /CLT - - - - -   | 7-27 |
| /CLT (Torque Limit Detection) signal - - - - -         | 7-27 |
| /COIN - - - - -  | 7-14 |
| /COIN (Positioning Completion) signal - - - - -        | 7-14 |
| /N-CL - - - - -  | 7-24 |
| /N-CL (Reverse External Torque Limit) signal - - - - - | 7-24 |
| /NEAR - - - - -  | 7-15 |
| /NEAR (Near) signal - - - - -                          | 7-15 |
| /P-CL - - - - -  | 7-24 |
| /P-CL (Forward External Torque Limit) signal - - - - - | 7-24 |
| /S-RDY - - - - -                                       | 7-12 |
| /TGON - - - - -  | 7-11 |
| /TGON (Rotation Detection) signal - - - - -            | 7-11 |
| /V-CMP - - - - -                                       | 7-12 |
| /V-CMP (Speed Coincidence Detection) signal - - - - -  | 7-12 |
| /VLT - - - - -   | 7-16 |
| /VLT (Speed Limit Detection) signal - - - - -          | 7-16 |
| /WARN - - - - -  | 7-10 |
| /WARN (Warning) signal - - - - -                       | 7-10 |

## A

|  |       |
|--|-------|
| A.CC0 - - - - -                                  | 7-31  |
| absolute encoder - - - - -                       | 7-28  |
| origin offset - - - - -                          | 6-51  |
| resetting - - - - -                              | 6-48  |
| wiring - - - - -                                 | 4-20  |
| acceleration reference unit - - - - -            | 14-23 |
| Acceleration User Unit - - - - -                 | 14-23 |
| Active Mode Function                             |       |
| operation example - - - - -                      | 11-20 |
| recovery method - - - - -                        | 11-22 |
| additional adjustment functions - - - - -        | 9-65  |
| alarm reset possibility - - - - -                | 15-5  |
| alarm tracing - - - - -                          | 10-17 |
| ALM - - - - -                                    | 7-10  |
| ALM (Servo Alarm) signal - - - - -               | 7-10  |
| Analog Monitor Connector - - - - -               | 4-48  |
| analog monitor factors - - - - -                 | 10-11 |
| anti-resonance control - - - - -                 | 9-50  |
| automatic detection of connected motor - - - - - | 6-12  |
| automatic gain switching - - - - -               | 9-65  |
| automatic notch filters - - - - -                | 9-32  |
| autotuning with a host reference - - - - -       | 9-35  |
| autotuning without a host reference - - - - -    | 9-24  |

## B

|                                 |      |
|---------------------------------|------|
| backlash compensation - - - - - | 9-72 |
| base block (BB) - - - - -       | vi   |
| battery                         |      |
| replacement - - - - -           | 15-3 |
| block diagram - - - - -         | 2-8  |

## C

|   |              |
|---|--------------|
| CCW - - - - -                                 | 6-13         |
| CiA402 drive profile - - - - -                | 2-6, 13-3    |
| clearing alarm history - - - - -              | 15-43        |
| CN1 - - - - -                                 | 4-36         |
| CN2A - - - - -                                | 4-19         |
| CN2B - - - - -                                | 4-19         |
| CN3 - - - - -                                 | 4-48         |
| CN5 - - - - -                                 | 4-48         |
| CN6A - - - - -                                | 4-46         |
| CN6B - - - - -                                | 4-46         |
| CN7 - - - - -                                 | 4-48         |
| coasting - - - - -                            | 6-36         |
| coasting to a stop - - - - -                  | 6-36         |
| coefficient of speed fluctuation - - - - -    | 2-7          |
| communications connectors - - - - -           | 2-6          |
| compatible adjustment functions - - - - -     | 9-87         |
| compliant communications standards - - - - -  | 2-6          |
| Computer Connector - - - - -                  | 4-48         |
| connecting a safety function device - - - - - | 11-17        |
| Control word - - - - -                        | 14-28        |
| countermeasures against noise - - - - -       | 4-5          |
| current control mode selection - - - - -      | 9-70         |
| current gain level setting - - - - -          | 9-71         |
| custom tuning - - - - -                       | 9-42         |
| CW - - - - -                                  | 6-13         |
| Cyclic Sync Torque Mode - - - - -             | 13-20        |
| Cyclic Synchronous Position Mode - - - - -    | 13-12, 14-48 |
| Cyclic Synchronous Velocity Mode - - - - -    | 13-18, 14-49 |

## D

|  |                     |
|--|---------------------|
| DC mode - - - - -  | 12-8, 12-10         |
| DC power supply input - - - - -                          | 4-12                |
| DC Reactor   |                     |
| terminals - - - - -                                      | 4-11                |
| wiring - - - - -   | 4-18                |
| decelerating to a stop - - - - -                         | 6-36                |
| deceleration monitoring - - - - -                        | 11-18, 11-19, 11-20 |
| detection timing for Overload Alarms (A.720) - - - - -   | 6-40                |
| detection timing for Overload Warnings (A.910) - - - - - | 6-39                |
| device control - - - - -                                 | 13-3                |
| diagnostic output circuits - - - - -                     | 4-45                |
| diagnostic tools - - - - -                               | 9-91                |
| digital I/O signals - - - - -                            | 13-22               |
| Digital Inputs - - - - -                                 | 14-54               |

digital inputs and outputs - - - - - 13-22, 14-54  
 Digital Outputs - - - - - 14-55  
 DINT - - - - - 1-6  
 Disable Operation Option Code - - - - - 14-33  
 displaying alarm history - - - - - 15-42  
 Distributed Clocks - - - - - 2-6  
 drive profile - - - - - 2-6, 13-3  
 dynamic brake applied - - - - - 6-36  
 Dynamic Brake Resistor  
     allowable energy consumption - - - - - 5-9  
     connections - - - - - 5-7  
     resistance - - - - - 5-9  
 dynamic brake stopping - - - - - 6-36

**E**

EasyFFT - - - - - 9-93  
 EDM1 (External Device Monitor) signal - - - - - 11-13  
 electronic gear - - - - - 6-41  
 emergency messages - - - - - 12-11  
 encoder resolution - - - - - 6-42  
 Encoder Selection (2705h) - - - - - 14-23  
 Error Code - - - - - 14-28  
 estimating the moment of inertia - - - - - 9-16  
 EtherCAT commands - - - - - 2-6  
 EtherCAT communications - - - - - 2-6  
 EtherCAT state machine - - - - - 12-3  
 event cycle - - - - - 14-19  
 events  
     event cycle - - - - - 14-19  
     reception events - - - - - 14-21  
     sync events - - - - - 12-8  
     SYNC0 event - - - - - 12-8  
     trigger events - - - - - 13-23  
 example of PDO data exchange timing in DC mode - - 12-10  
 External Regenerative Resistor - - - - - 6-54  
 external torque limits - - - - - 7-24

**F**

Fault Reaction Option Code - - - - - 14-34  
 feedforward - - - - - 9-33, 9-87  
 feedforward compensation - - - - - 9-87  
 FG - - - - - 4-8  
 FMMU - - - - - 2-6  
 Following Error Actual Value - - - - - 14-41  
 Following Error Time Out - - - - - 14-40  
 Following Error Window - - - - - 14-40  
 forward rotation - - - - - 6-13  
 Free-Run mode - - - - - 12-8  
 friction compensation - - - - - 9-33, 9-68

**G**

gain switching - - - - - 9-65  
 gravity compensation - - - - - 9-69

grounding - - - - - 4-8  
 group 1 alarms - - - - - 6-37  
 group 2 alarms - - - - - 6-37

**H**

Halt Option Code - - - - - 14-33  
 hard wire base block (HWBB) - - - - - 11-5  
     detecting errors in HWBB signal - - - - - 11-9  
     HWBB input signal specifications - - - - - 11-10  
 hard wire base block (HWBB) state - - - - - 11-7  
     resetting - - - - - 11-8  
 holding brake - - - - - 6-31  
 Home Offset - - - - - 14-38  
 homing - - - - - 13-14, 14-38  
 Homing Acceleration - - - - - 14-39  
 Homing Method - - - - - 13-14, 14-38  
 Homing Mode - - - - - 14-38  
 HWBB - - - - - 11-5, 11-7  
     detecting errors in HWBB signal - - - - - 11-9  
     HWBB input signal specifications - - - - - 11-10  
 HWBB state  
     resetting - - - - - 11-8  
 /HWBB1 - - - - - 4-44  
 /HWBB2 - - - - - 4-44

**I**

I/O signals  
     allocations - - - - - 7-3  
     functions - - - - - 4-36  
     monitoring - - - - - 10-3, 10-5  
     names - - - - - 4-36  
     wiring example - - - - - 4-39  
 indicators - - - - - 2-6  
 initializing the vibration detection level - - - - - 7-37  
 input signals  
     allocations - - - - - 7-4  
 INT - - - - - 1-6  
 internal torque limits - - - - - 7-23  
 Interpolated Position Mode - - - - - 13-9, 13-10, 14-42  
 interpolated positioning - - - - - 13-12  
 Interpolation Data Read/Write Pointer Position  
 Monitor - - - - - 14-47  
 Interpolation Data Record - - - - - 14-42  
 Interpolation Data Record for 1st Profile - - - - - 14-46  
 Interpolation Data Record for 2nd Profile - - - - - 14-46  
 interpolation position reference - - - - - 14-42  
 interpolation position reference cycle - - - - - 14-43  
 interpolation processing - - - - - 13-9  
 Interpolation Profile Select - - - - - 14-46  
 interpolation speed exceeded - - - - - 14-30  
 Interpolation Submode Select - - - - - 14-42  
 Interpolation Time Period - - - - - 14-43  
 I-P control - - - - - 9-84

- J**
- jogging - - - - - 8-7
- L**
- limiting torque - - - - - 7-23
- Linear Encoder
- wiring example - - - - - 4-20
- linear encoder
- feedback resolution - - - - - 6-43
- scale pitch setting - - - - - 6-14
- Linear Servomotor - - - - - vi
- Linear Servomotor Overheat Protection Signal - - - - - 4-36
- list of alarms - - - - - 15-5
- list of parameters - - - - - 16-2
- list of warnings - - - - - 15-46
- M**
- mailbox - - - - - 2-6
- Main Circuit Cable - - - - - vi
- manual tuning - - - - - 9-77
- Manufacturer Interpolation Data Configuration  
for 1st Profile - - - - - 14-43
- Manufacturer Interpolation Data Configuration  
for 2nd Profile - - - - - 14-44
- Max. Profile Velocity - - - - - 14-36
- Max. Torque - - - - - 14-51
- mechanical analysis - - - - - 9-91
- mode switching (changing between proportional  
and PI control) - - - - - 9-88
- Modes of Operation - - - - - 14-34
- Modes of Operation Display - - - - - 14-34
- Momentary Power Interruption Hold Time - - - - - 7-18
- monitor factors - - - - - 10-11
- Motion Monitor - - - - - 10-3
- motor current detection signal
- automatic adjustment - - - - - 7-41
- manual adjustment - - - - - 7-43
- offset - - - - - 7-41
- motor direction setting - - - - - 6-13
- motor maximum speed - - - - - 7-21
- motor overload detection level - - - - - 6-39
- Motor Rated Torque - - - - - 14-50
- multiturn limit - - - - - 7-29
- Multiturn Limit Disagreement - - - - - 7-31
- N**
- Negative Torque Limit Value - - - - - 14-51
- Noise Filter - - - - - 4-6
- Noise Filter connection precautions - - - - - 4-7
- N-OT - - - - - 6-25
- N-OT (Reverse Drive Prohibit) signal - - - - - 6-25
- notch filters - - - - - 9-80
- O**
- object dictionary - - - - - 12-6
- object dictionary list - - - - - 14-3
- object list - - - - - 16-39
- operation for momentary power interruptions - - - - - 7-18
- operation modes - - - - - 13-5, 14-34
- origin search - - - - - 8-19
- overload warnings - - - - - 6-39
- overtravel - - - - - 6-25
- release method selection - - - - - 6-29
- warnings - - - - - 6-28
- P**
- parameter settings recording table - - - - - 16-54
- parameters
- classification - - - - - 6-3
- initializing parameter settings - - - - - 6-9
- notation (selecting functions) - - - - - vii, 6-4
- setting methods - - - - - 6-5
- write prohibition setting - - - - - 6-6
- PDO mapping objects - - - - - 14-10
- PDO mappings - - - - - 12-6, 14-10
- default settings - - - - - 12-7
- object dictionary - - - - - 12-6
- object dictionary list - - - - - 14-3
- setting procedure - - - - - 12-7
- photocoupler input circuits - - - - - 4-41
- photocoupler output circuits - - - - - 4-42
- physical layer - - - - - 2-6
- PI control - - - - - 9-84
- polarity detection - - - - - 6-22
- polarity sensor - - - - - 6-21
- Position Actual Internal Value - - - - - 14-40
- Position Actual Value - - - - - 14-40
- Position Demand Internal Value - - - - - 14-40
- Position Demand Value - - - - - 14-40
- position integral - - - - - 9-90
- position loop gain - - - - - 9-78
- position reference unit - - - - - 14-22
- Position User Unit - - - - - 14-22
- Position Window Time - - - - - 14-41
- positioning completed width - - - - - 7-14
- Positive Torque Limit Value - - - - - 14-51
- P-OT - - - - - 6-25
- P-OT (Forward Drive Prohibit) signal - - - - - 6-25
- process data - - - - - 2-6
- Profile Acceleration - - - - - 14-37
- Profile Deceleration - - - - - 14-37
- Profile Position Mode - - - - - 13-6, 14-36
- Profile Torque Mode - - - - - 13-19
- Profile Velocity - - - - - 14-37
- Profile Velocity Mode - - - - - 13-17, 14-49

program jogging - - - - - 8-13  
 operation pattern - - - - - 8-14

**Q**

Quick Stop - - - - -14-32  
 Quick Stop command - - - - -14-37  
 Quick Stop Deceleration - - - - -14-37  
 Quick Stop Option Code - - - - -14-32

**R**

Receive PDO Mapping - - - - -14-10  
 reception events - - - - -14-21  
 reference unit - - - - - 6-41  
 Regenerative Resistor  
 connection - - - - - 4-17  
 regenerative resistor - - - - - 6-54  
 regenerative resistor capacity - - - - - 6-54  
 resetting alarms - - - - -15-41  
 risk assessment - - - - - 11-6  
 Rotary Servomotor - - - - - vi

**S**

Safety Function Signals - - - - - 4-43  
 safety functions - - - - - 11-3  
 application examples - - - - -11-14  
 monitoring - - - - - 10-5  
 precautions - - - - - 11-4  
 verification test - - - - -11-16  
 safety input circuits - - - - - 4-44  
 SBB-D function - - - - -11-18  
 operation example - - - - -11-18  
 recovery method - - - - -11-18  
 scale pitch - - - - - 6-14  
 selecting the phase sequence  
 for a Linear Servomotor - - - - - 6-19  
 selecting torque limits - - - - - 7-23  
 SEMI F47 function - - - - - 7-19  
 Serial Communications Connector - - - - - 4-48  
 Serial Converter Unit - - - - - 6-14  
 Servo Drive - - - - - vi  
 servo gains - - - - - 9-77  
 servo lock - - - - - vi  
 servo OFF - - - - - vi  
 servo ON - - - - - vi  
 Servo System - - - - - vi  
 Servomotor - - - - - vi  
 Servomotor stopping method for alarms - - - - - 6-37  
 SERVOPACK - - - - - vi  
 inspections and part replacement - - - - - 15-2  
 part names - - - - - 1-9  
 ratings - - - - - 2-2  
 specifications - - - - - 2-4  
 setting the origin - - - - - 6-51

setting the position deviation overflow alarm level - - - - -9-8  
 setting the position deviation overflow alarm level  
 at servo ON - - - - -9-10  
 setting the vibration detection level - - - - -9-10  
 setup parameters - - - - -6-3  
 SG - - - - -4-37  
 Shutdown Option Code - - - - - 14-32  
 SigmaWin+ - - - - - vi  
 signal allocations - - - - -7-3  
 sink circuits - - - - -4-41  
 SINT - - - - -1-6  
 Slave Information IF - - - - -2-6  
 SLS-D function - - - - - 11-20  
 operation example - - - - - 11-20  
 recovery method - - - - - 11-20  
 software limits - - - - -7-22  
 Software Position Limit - - - - - 14-36  
 software reset - - - - -7-35  
 source circuits - - - - -4-41  
 speed detection method selection - - - - -9-71  
 speed limit during torque control - - - - -7-16  
 speed loop gain - - - - -9-79  
 speed loop integral time constant - - - - -9-79  
 speed reference unit - - - - - 14-23  
 SPM-D function - - - - - 11-19  
 operation example - - - - - 11-19  
 recovery method - - - - - 11-19  
 state machine control commands - - - - - 13-4  
 Status Monitor - - - - -10-3  
 Status word - - - - - 13-4, 14-30  
 stopping by applying the dynamic brake - - - - -6-36  
 stopping method for servo OFF - - - - -6-37  
 storage humidity - - - - -2-4  
 storage temperature - - - - -2-4  
 STRING - - - - -1-6  
 Supported Drive Modes - - - - - 14-35  
 surrounding air humidity - - - - -2-4  
 surrounding air temperature - - - - -2-4  
 switching condition A - - - - -9-66  
 Sync Error Settings - - - - - 14-21  
 sync events - - - - -12-8  
 Sync Manager Communication Objects - - - - - 14-18  
 Sync Manager Communication Type - - - - - 14-18  
 Sync Manager PDO Assignment - - - - - 14-18  
 Sync Manager Synchronization - - - - - 14-19  
 SYNC0 event - - - - -12-8  
 synchronization with distributed clocks - - - - -12-8  
 SyncManager - - - - -2-6

**T**

Target Position - - - - - 14-36  
 Target Torque - - - - - 14-50

|   |       |
|---|-------|
| Target Velocity                         | 14-49 |
| test without a motor                    | -8-21 |
| TH_A                                    | -4-36 |
| TH_B                                    | -4-36 |
| three-phase, 400-VAC power supply input | -4-11 |
| time required to brake                  | -6-31 |
| time required to release brake          | -6-31 |
| Torque Actual Value                     | 14-50 |
| Torque Demand Value                     | 14-50 |
| torque limit function                   | 14-51 |
| torque limits                           | 13-21 |
| Torque Offset                           | 14-48 |
| torque reference filter                 | -9-80 |
| Torque Slope                            | 14-50 |
| touch probe                             | 13-23 |
| example of execution procedure          | 13-24 |
| Touch Probe 1 Position Value            | 14-53 |
| Touch Probe 2 Position Value            | 14-53 |
| Touch Probe Function                    | 14-52 |
| touch probe function                    | 14-52 |
| Touch Probe Status                      | 14-53 |
| Transmit PDO Mapping                    | 14-14 |
| trial operation                         |       |
| EtherCAT (CoE) Communications           | -8-10 |
| trigger events                          | 13-23 |
| troubleshooting warnings                | 15-47 |
| tuning parameters                       | 6-4   |
| tuning-less                             |       |
| load level                              | -9-14 |
| rigidity level                          | -9-14 |
| tuning-less function                    | -9-12 |

## U

|       |     |
|-------|-----|
| UDINT | 1-6 |
| UINT  | 1-6 |
| USINT | 1-6 |

## V

|                       |       |
|-----------------------|-------|
| Velocity Actual Value | 14-49 |
| Velocity Demand Value | 14-49 |
| Velocity Offset       | 14-48 |
| Velocity User Unit    | 14-23 |
| Velocity Window       | 14-49 |
| Velocity Window Time  | 14-49 |
| vibration suppression | -9-55 |

## W

|                    |       |
|--------------------|-------|
| writing parameters | -6-15 |
|--------------------|-------|

## Z

|                     |       |
|---------------------|-------|
| zero clamping       | -6-36 |
| zero-speed stopping | -6-36 |

## Revision History

The revision dates and numbers of the revised manuals are given on the bottom of the back cover.

MANUAL NO. SIEP S800002 19A <1>-0  
 WEB revision number  
 Revision number  
 Published in Japan June 2016  
 Date of publication

| Date of Publication | Rev. No. | Web Rev. No. | Section  | Revised Contents  |
|---------------------|----------|--------------|--|---|
| November 2024       | <13>     | 0            | 1.4, 4.2, 7.6.2, 10.2.2, 14.17, 15.2.2, 16.1.2, 16.2, 17.2.2 | Partly revised.   |
| April 2024          | <12>     | 0            | All chapters   | Partly revised.   |
|                     |          |              | Back cover   | Revision: Address   |
| September 2023      | <11>     | 0            | 2.1.1, 4.2, 4.4.3, 4.5.4, 4.7.1, 15.2.2                      | Partly revised.   |
|                     |          |              | Back cover   | Revision: Address   |
| March 2023          | <10>     | 0            | Preface, 1.3, 3.7, 7.13.1, 15.2.2                            | Partly revised.   |
|                     |          |              | Back cover   | Revision: Address   |
| September 2022      | <9>      | 0            | 7.1.6, 9.12.1, 9.12.4, 16.1.2                                | Partly revised.   |
|                     |          |              | Back cover   | Revision: Address   |
| February 2022       | <8>      | 0            | Preface, 1.6.1, 1.8.1, 14.6, 16.2                            | Partly revised.   |
|                     |          |              | Back cover   | Revision: Address   |
| September 2021      | <7>      | 0            | All chapters   | Partly revised.   |
| August 2020         | <6>      | 0            | 6.5, 6.14.1, 15.2.1, 15.2.2                                  | Partly revised.   |
| February 2020       | <5>      | 0            | 4.4.3, 6.14.1, 6.16.2  | Addition: Information on Linear Encoder from Canon Precision Inc.   |
| November 2019       | <4>      | 0            | All chapters   | Partly revised.   |
|                     |          |              | Back cover   | Revision: Address   |
| February 2019       | <3>      | 0            | 6.1.4, 8.6.3   | Revision: Information in table of restrictions  |
|                     |          |              | 10.2.2, 10.2.3, 16.2.6, 16.2.7, 18.2.1                       | Partly revised.   |
|                     |          |              | 16.2.3   | Addition: Reset procedure with the SigmaWin+  |
|                     |          |              | Back cover   | Revision: Address   |
| October 2018        | <2>      | 0            | All chapters   | Partly revised.   |
|                     |          |              | 1.8  | Newly added.  |
|                     |          |              | 2.4  | Revision: Magnetic Contactor → Brake relay  |
|                     |          |              | 4.4.3, 6.14.1, 6.16.2  | Addition: Absolute linear encoder from Fagor Automation S. Coop.  |
|                     |          |              | 6.1.4, 8.6.3   | Revision: Footnote in Origin Search   |
|                     |          |              | 6.14.5   | Newly added.  |
|                     |          |              | 9.11.3   | Enable timing for Pn423   |
|                     |          |              | 14.7   | Revision: Description of value 0 of bit 10 for "Bits 10, 12, and 13: Cyclic Synchronous Position, Velocity, or Torque Mode" |
|                     |          |              | 16.2   | Addition: Footnote 4  |
|                     |          |              | 17.1.5   | Deleted.  |
|                     |          |              | Back cover   | Revision: Address   |



| Date of Publication | Rev. No. | Web Rev. No. | Section      | Revised Contents                       |
|---------------------|----------|--------------|--------------|--|
| December 2017       | <1>      | 0            | Preface      | Revision: Information on EU Directives |
|                     |          |              | Chapter 5    | Addition: Information on dynamic brake |
|                     |          |              | All chapters | Partly revised.                        |
|                     |          |              | Back cover   | Revision: Address                      |
| June 2016           | -        | -            | -            | First edition                          |

# Σ-7-Series AC Servo Drive

# Σ-7W SERVOPACK with

# 400V-Input Power and EtherCAT (CoE)

# Communications References

# Product Manual

---

#### **IRUMA BUSINESS CENTER (SOLUTION CENTER)**

480, Kamifujisawa, Iruma, Saitama, 358-8555, Japan  
Phone: +81-4-2962-5151 Fax: +81-4-2962-6138  
www.yaskawa.co.jp

#### **YASKAWA AMERICA, INC.**

2121, Norman Drive South, Waukegan, IL 60085, U.S.A.  
Phone: +1-800-YASKAWA (927-5292) or +1-847-887-7000 Fax: +1-847-887-7310  
www.yaskawa.com

#### **YASKAWA ELÉTRICO DO BRASIL LTDA.**

777, Avenida Piraporinha, Diadema, São Paulo, 09950-000, Brasil  
Phone: +55-11-3585-1100 Fax: +55-11-3585-1187  
www.yaskawa.com.br

#### **YASKAWA EUROPE GmbH**

Philipp-Reis-Str. 6, 65795 Hattersheim am Main, Germany  
Phone: +49-6196-569-300 Fax: +49-6196-569-398  
www.yaskawa.eu.com E-mail: info@yaskawa.eu.com

#### **YASKAWA ELECTRIC KOREA CORPORATION**

6F, 112, LS-ro, Dongan-gu, Anyang-si, Gyeonggi-do, Korea  
Phone: +82-31-8015-4224 Fax: +82-31-8015-5034  
www.yaskawa.co.kr

#### **YASKAWA ASIA PACIFIC PTE. LTD.**

30A, Kallang Place, #06-01, 339213, Singapore  
Phone: +65-6282-3003 Fax: +65-6289-3003  
www.yaskawa.com.sg

#### **YASKAWA ELECTRIC (THAILAND) CO., LTD.**

59, 1F-5F, Flourish Building, Soi Ratchadapisek 18, Ratchadapisek Road, Huaykwang, Bangkok, 10310, Thailand  
Phone: +66-2-017-0099 Fax: +66-2-017-0799  
www.yaskawa.co.th

#### **YASKAWA ELECTRIC (CHINA) CO., LTD.**

22F, Link Square 1, No.222, Hubin Road, Shanghai, 200021, China  
Phone: +86-21-5385-2200 Fax: +86-21-5385-3299  
www.yaskawa.com.cn

#### **YASKAWA ELECTRIC (CHINA) CO., LTD. BEIJING OFFICE**

Room 1011, Tower W3 Oriental Plaza, No.1, East Chang An Avenue,  
Dong Cheng District, Beijing, 100738, China  
Phone: +86-10-8518-4086 Fax: +86-10-8518-4082

#### **YASKAWA ELECTRIC TAIWAN CORPORATION**

12F, No. 207, Section 3, Beishin Road, Shindian District, New Taipei City 23143, Taiwan  
Phone: +886-2-8913-1333 Fax: +886-2-8913-1513 or +886-2-8913-1519  
www.yaskawa.com.tw

---

# YASKAWA

YASKAWA ELECTRIC CORPORATION

In the event that the end user of this product is to be the military and said product is to be employed in any weapons systems or the manufacture thereof, the export will fall under the relevant regulations as stipulated in the Foreign Exchange and Foreign Trade Regulations. Therefore, be sure to follow all procedures and submit all relevant documentation according to any and all rules, regulations and laws that may apply. Specifications are subject to change without notice for ongoing product modifications and improvements.

© 2016 YASKAWA ELECTRIC CORPORATION

MANUAL NO. SIEP S800002 19N <13>-0

Published in Japan November 2024

23-4-19

Original instructions